

MODEL: M57

# USER MANUAL



Sihoo Store US



Sihoo Store EU



Instagram



Thank you for choosing Sihoo.

We hope our products can enhance your comfort and promote a healthy lifestyle.

We take pride in offering a comprehensive three-year warranty for all Sihoo products, supported by round-the-clock customer service to guarantee your utmost satisfaction.

Should you require any assistance, please do not hesitate to contact us at

[service@sihoooffice.com](mailto:service@sihoooffice.com)

Kindly note: To expedite our services, kindly include your order number when reaching out to our customer support.

Sincerely,

**SIHOO**

Sihooを選んでいただき、ありがとうございます。

私たちの製品がお客様の快適さを向上させ、健康的なライフスタイルを促進できることを願っています。

Sihooのすべての製品に対して、包括的な3年間の保証を提供し、常時対応のカスタマーサービスでお客様の最大の満足を保証しております。

お手伝いが必要な場合は、どうぞお気軽に  
[service@sihoooffice.com](mailto:service@sihoooffice.com) までお問い合わせください。

ご注意：サービスを迅速に提供するために、カスタマーサポートにお問い合わせいただく際には、ご注文番号をご記入いただくと助かります。

どうぞよろしく願いいたします。

**SIHOO**

# SIHOO ABOUT US



Sihoo is a renowned specialist in ergonomic furniture, dedicated to offering healthy and comfortable ergonomic chairs. With a 12-year emphasis on technology and well-being, Sihoo's mission is to enhance people's lives through innovative and ergonomic furniture solutions. Presently, Sihoo's ergonomic chairs are available in over 100 countries and have garnered acclaim among Fortune 500 companies, as well as in more than 10 million households worldwide.

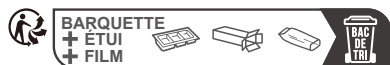

Séparez les éléments avant de trier



## CAUTION !

Work on gas springs only by trained specialist personnel.

## ACHTUNG !

Arbeiten an Gasfedern nur durch eingewiesenes Fachpersonal.

# CONTENTS

1. User Manual	P01-P04
2. Benutzerhandbuch	P05-P08
3. Manuel utilisateur	P09-P12
4. Manuale utente	P13-P16
5. Manual de usuario	P17-P20
6. 組立説明書	P21-P24
7. دليل الاستخدام	P25-P28



### Parts List

(Please refer to the actual size. Each type of screw and washer has one reserved as a spare.)

Key	Description	Part	Qty.	Spare
A	Castor		5pcs	
B	Chair leg tube		5pcs	
C	Chair leg tube connection base		1pc	
D	Hex wrench		1pc	
E	Chair leg screw (M6X12)		10pcs	1pc
F	Small Shim		10pcs	1pc
G	Chair foot trim cover		1pc	
H	Gas lift		1pc	
I	Seat cushion		1pc	
J	Backrest		1pc	
K	Back plate screw(M8*45)		3pcs	1pc
L	Armrest		1pair	
M	Armrest screw/ Mechanism screw(M6*20)		10pcs	1pc
N	Big Shim		4pcs	1pc
O	Mechanismus		1pc	
P	Kopfstütze		1pc	

Note: Please sort the screws and measure their lengths beforehand for easier assembly.

### Step 1

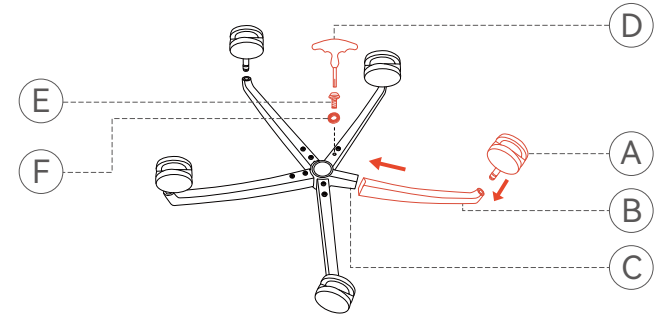

Use 10 screws of M6\*12 specification to fix the five chair leg tubes to the chair leg tube connection base and then insert the wheels;

### Step 2

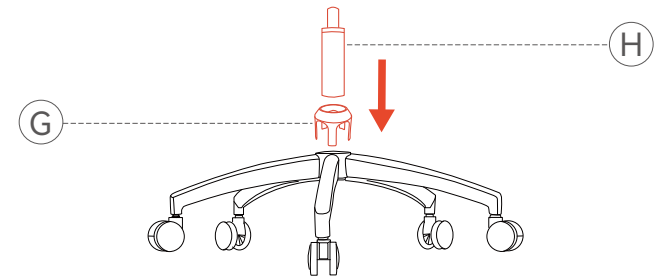

First, insert the chair foot trim cover into the chair foot, and then put the air pressure rod into the middle hole of chair leg tube connection base;

### Step 3

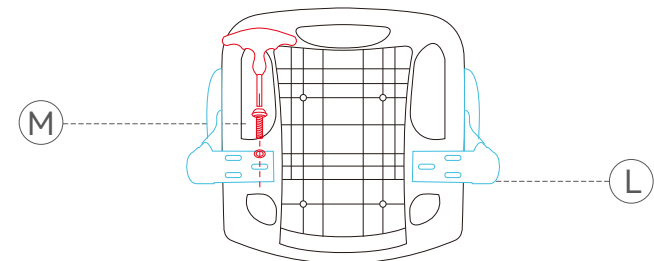

Fix the armrest to the seat cushion with 6pcs small shim and 6pcs (M6\*20) screws.



# Operation Instructions

(Please refer to the actual size.)

## Step 4

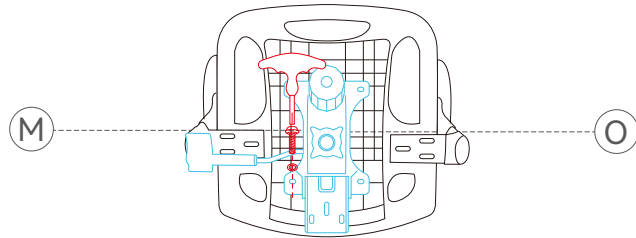

Fix the mechanism to the seat cushion with 4pcs small shim and 4pcs (M6\*20) screws.

## Step 5

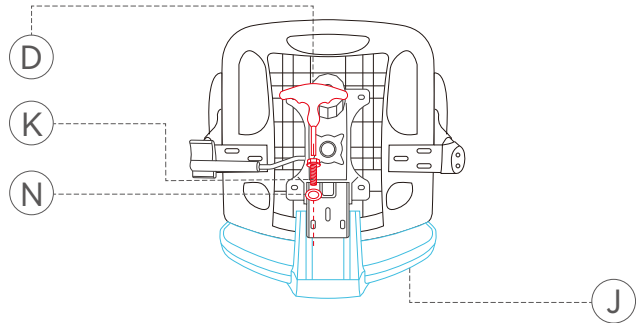

Fix the back plate to the seat cushion with 3pcs big shim and 3pcs (M8\*45) screws.

## Step 6



Put the mechanism into the gaslift.

## Step 7

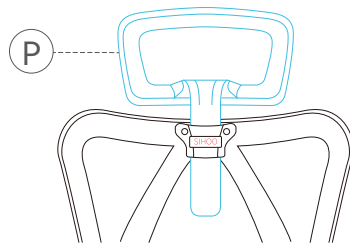

Insert the headrest into the slot.

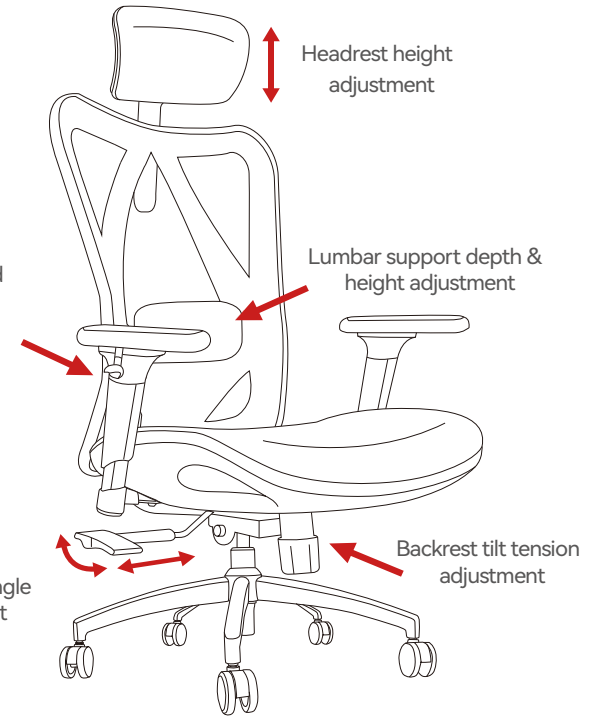

## Safety Installation

1. Each chair is designed to support the weight of one person only.
2. Please use the chair on a flat, even surface.
3. Do not allow children under the age of 5 to sit on the chair without supervision.
4. Avoid sitting on the armrest to prevent potential accidents.
5. Do not stand on the chair, use it as a ladder, or step on it.
6. Please refrain from placing excessive weight on the chair or using it as a makeshift trolley.
7. Avoid using sharp or pointed objects that could damage the chair, and keep it away from open flames or sources of heat.
8. For your safety, do not attempt to disassemble the gas lift mechanism.



## Stückliste

(Bitte beachten Sie die tatsächliche Größe. Von jeder Art Schraube und Unterlegscheibe ist jeweils eine als Ersatz vorgesehen.)

Schlüssel	Beschreibung	Teil	Menge	Ersatz
A	Castor		5Stück	
B	Stuhlbeinrohr		5Stücke	
C	Stuhlbeinrohrverbindung Basis		1Stück	
D	Inbusschlüssel		1pc	
E	Stuhlbeinschraube (M6 * 12)		10pcs	1pc
F	Kleine Distanzscheibe		10pcs	1pc
G	Stuhlfußverkleidung		1Stück	
H	Gaslift		1Stück	
I	Sitz		1pc	
J	Rückenlehne		1pc	
K	Rückplattenschraube(M8*45)		3Stück	1pc
L	Armlehnen		1Paar	
M	Armlehenschraube/ Mechanismusschraube (M6*20)		10pcs	1pc
N	Große Distanzscheibe		4pcs	1pc
O	Mechanismus		1pc	
P	Kopfstütze		1pc	

Hinweis: Bitte sortieren Sie die Schrauben im Voraus und messen Sie ihre Längen, um die Montage zu erleichtern.



## Montageanleitung

(Bitte beachten Sie die tatsächliche Größe.)

Nach  
Videoanleitung suchen



### Schritt 1

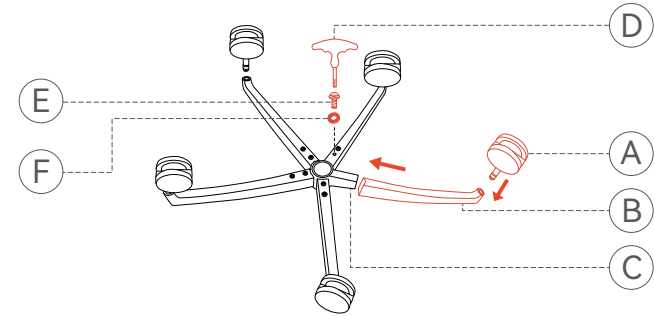

Verwenden Sie 10 Schrauben der Spezifikation M6\*12, um die fünf Stuhlbeinrohre an der Stuhlbeinrohr-Verbindungsbasis zu befestigen, und setzen Sie dann die Räder ein;

### Schritt 2

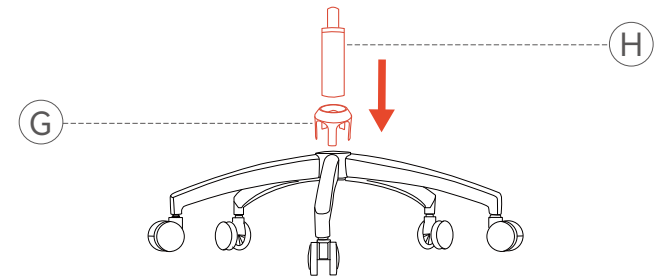

Setzen Sie zuerst die Verkleidungsabdeckung des Stuhlfußes in den Stuhlfuß ein und stecken Sie dann die Luftdruckstange in das mittlere Loch der Verbindungsbasis des Stuhlbeinrohrs;

### Schritt 3

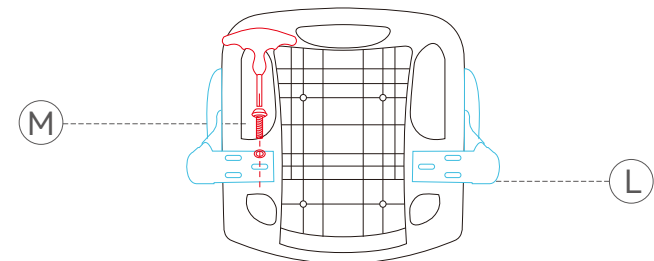

Befestigen Sie die Armlehne mit 6 kleinen Scheiben und 6 Schrauben (M6\*20) am Sitz.



## Betriebsanleitung

(Bitte beachten Sie die tatsächliche Größe.)

### Schritt 4

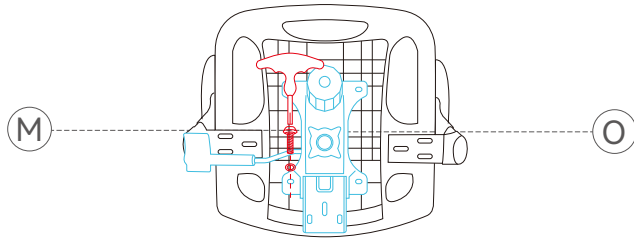

Befestigen Sie den Mechanismus mit 4 kleinen Scheiben und 4 Schrauben (M6\*20) am Sitz.

### Schritt 5

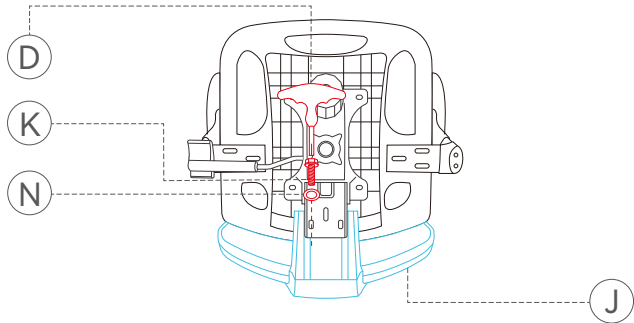

Befestigen Sie die Rückenplatte mit 3 großen Distanzscheiben und 3 Schrauben (M8\*45) am Sitz.

### Schritt 6



Setzen Sie den Mechanismus in den Gasheber.

### Schritt 7

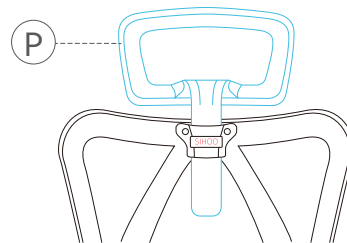

Setzen Sie die Kopfstütze in den Schlitz ein.



### Sicherheitsanweisungen

1. Jeder Stuhl ist nur für das Gewicht einer Person ausgelegt.
2. Bitte verwenden Sie den Stuhl auf einer flachen, ebenen Oberfläche.
3. Erlauben Sie Kindern unter 5 Jahren nicht, ohne Aufsicht auf dem Stuhl zu sitzen.
4. Vermeiden Sie das Sitzen auf der Armlehne, um mögliche Unfälle zu verhindern.
5. Stehen Sie nicht auf dem Stuhl, verwenden Sie ihn nicht als Leiter oder Tritt.
6. Bitte verzichten Sie darauf, übermäßiges Gewicht auf den Stuhl zu legen oder ihn als improvisierten Transportwagen zu verwenden.
7. Verwenden Sie keine scharfen oder spitzen Gegenstände, die den Stuhl beschädigen könnten, und halten Sie ihn fern von offenen Flammen oder Hitzequellen.
8. Aus Sicherheitsgründen versuchen Sie nicht, den Gasliftmechanismus zu demontieren.



## Liste des pièces

(Veuillez vous référer à la taille réelle. Chaque type de vis et de rondelle en a une de réservée en tant que pièce de rechange.)

Clé	Description	Pièce	Qté.	De rechange
A	Roulette		5pcs	
B	Tube de jambe de chaise		5pièces	
C	Base de connexion du tube de jambe de chaise		1pc	
D	Clé hexagonale		1pc	
E	Vis de jambe de chaise (M6 * 12)		10pcs	1pc
F	Petite cale		10pcs	1pc
G	Couverture de garniture de pied de chaise		1pièce	
H	Élévateur de gaz		1pc	
I	Siège		1pc	
J	Dossier		1pc	
K	Vis de la plaque arrière (M8*45)		3pcs	1pc
L	Accoudoirs		1paire	
M	Vis d'accoudoir/Mécanisme à vis (M6*20)		10pcs	1pc
N	Grande cale		4pcs	1pc
O	Mécanisme		1pc	
P	Appuie-tête		1pc	

Note : Veuillez trier les vis et mesurer leurs longueurs au préalable pour faciliter l'assemblage.



## Instructions d'assemblage

(Veuillez vous référer à la taille réelle.)

Guide de numérisation vidéo



### Étape 1

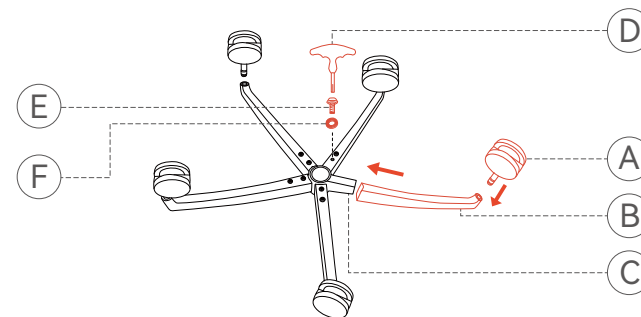

Utilisez 10 vis de spécification M6 \* 12 pour fixer les cinq tubes de pied de chaise à la base de connexion du tube de pied de chaise, puis insérez les roues ;

### Étape 2

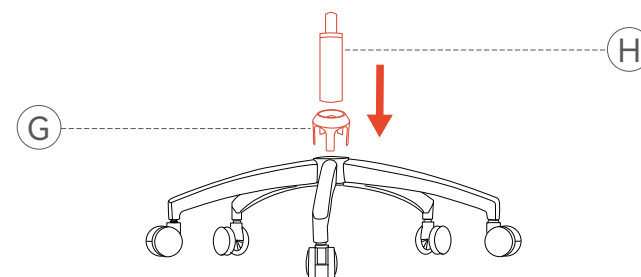

Tout d'abord, insérez le couvercle de garniture du pied de chaise dans le pied de chaise, puis placez la tige de pression d'air dans le trou central de la base de connexion du tube de pied de chaise ;

### Étape 3

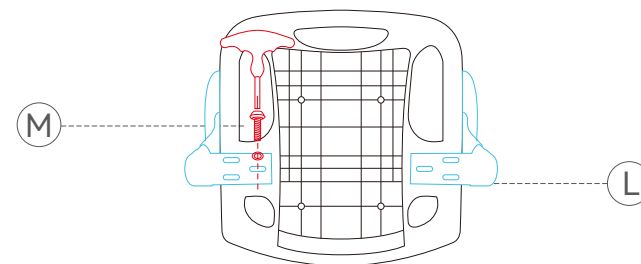

Fixez l'accoudoir au siège à l'aide d'une petite cale d'épaisseur et de 6 vis (M6\*20).





## Instructions d'utilisation

(Veuillez vous référer à la taille réelle.)

### Étape 4

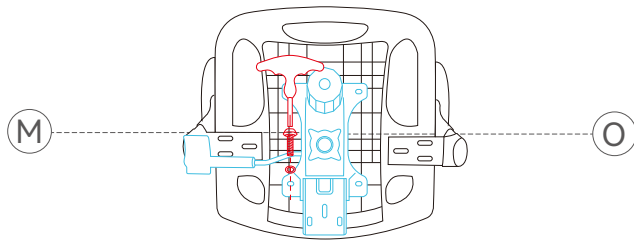

Fixez le mécanisme au siège à l'aide de 4 petites cales et de 4 vis (M6\*20).

### Étape 5

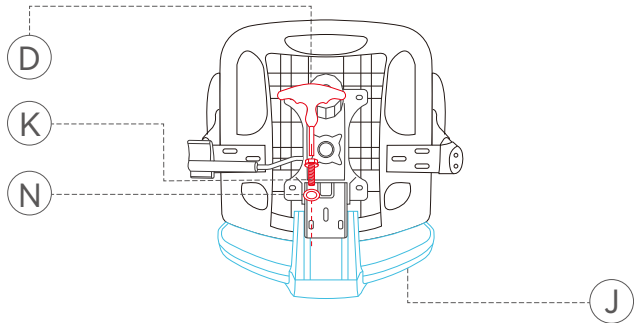

Fixez la plaque arrière au siège avec 3 grosses cales et 3 vis (M8\*45).

### Étape 6



Placez le mécanisme dans l'ascenseur à gaz.

### Étape 7

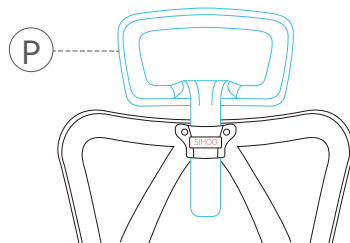

Insérez l'appui-tête dans la fente.

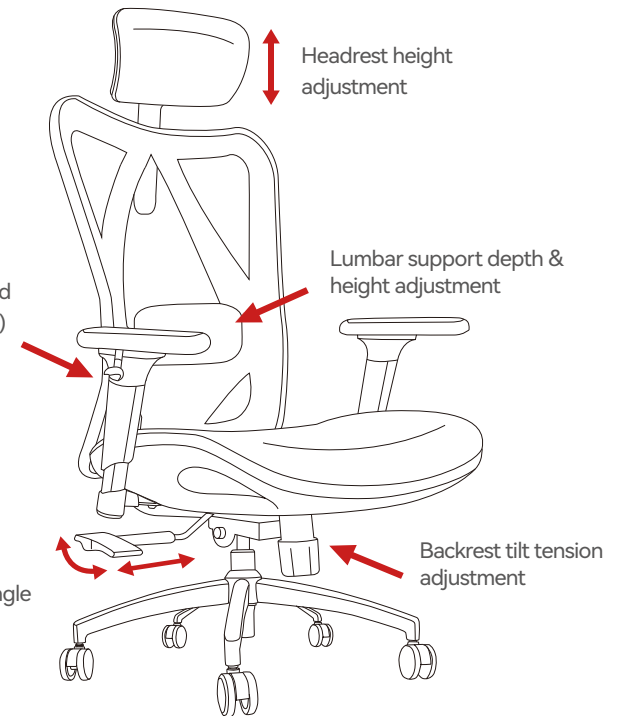

### Instructions de sécurité

1. Chaque chaise est conçue pour supporter le poids d'une seule personne.
2. Veuillez utiliser la chaise sur une surface plane et stable.
3. Ne permettez pas aux enfants de moins de 5 ans de s'asseoir sur la chaise sans surveillance.
4. Évitez de vous asseoir sur l'accoudoir pour prévenir d'éventuels accidents.
5. Ne montez pas sur la chaise, ne l'utilisez pas comme une échelle, ni ne montez dessus.
6. Veuillez vous abstenir de placer un poids excessif sur la chaise ou de l'utiliser comme un chariot improvisé.
7. Évitez d'utiliser des objets pointus ou coupants qui pourraient endommager la chaise, et éloignez-la des flammes nues ou de toute source de chaleur.
8. Pour votre sécurité, ne tentez pas de désassembler le mécanisme de levage au gaz.



## Lista delle parti

(Si prega di fare riferimento alle dimensioni effettive. C'è una riserva per ciascun tipo di vite e rondella.)

Chiave	Descrizione	Parte	Qtà.	Di Ricambio
A	Casto		5pcs	
B	Tubo della gamba della sedia		5 pezzi	
C	Base di collegamento del tubo della gamba della sedia		1 pezzo	
D	Chiave esagonale		1pc	
E	Vite per gambe della sedia (M6 * 12)		10pcs	1pc
F	Piccolo spessore		10pz	1pc
G	Copertura del rivestimento del piede della sedia		1pc	
H	Gas lift		1 pz	
I	Sede		1pc	
J	Schienale		1pc	
K	Vite del piatto posteriore (M8*45)		3pcs	1pc
L	Braccioli		1 paio	
M	Vite del bracciolo/Vite del meccanismo (M6*20)		10pcs	1pc
N	Big Shim		4pcs	1pc
O	Meccanismo		1pc	
P	Poggiatesta		1pc	

Nota: Si prega di ordinare le viti e misurare in anticipo le loro lunghezze per facilitare l'assemblaggio.



## Istruzioni di montaggio

(Si prega di fare riferimento alle dimensioni effettive.)

Scansione per Guida Video



### Paso 1

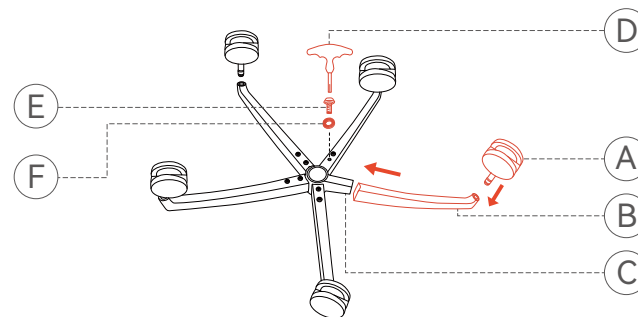

Utilizzare 10 viti della specifica M6\*12 per fissare i cinque tubi della gamba della sedia alla base di collegamento del tubo della gamba della sedia, quindi inserire le ruote;

### Paso 2

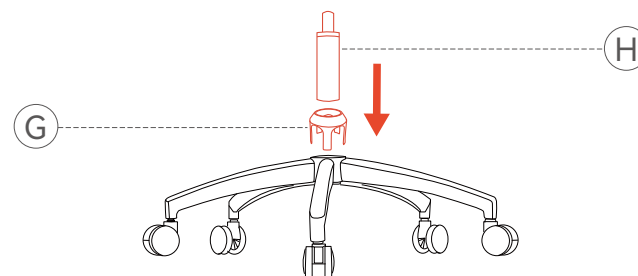

In primo luogo, inserire la copertura del rivestimento del piedino della sedia nel piedino della sedia, quindi inserire l'asta della pressione dell'aria nel foro centrale della base di collegamento del tubo della gamba della sedia;

### Paso 3

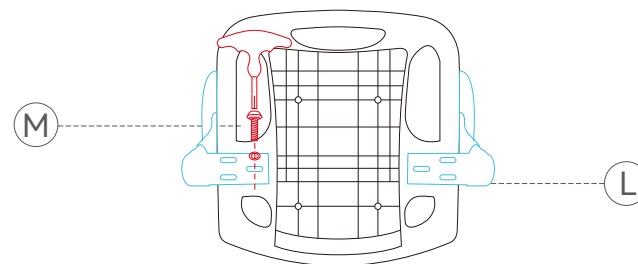

Fissare il bracciolo al sedile con viti 6pcs piccolo e 6 pezzi (M6\*20).



## Istruzioni per l'Uso

(Si prega di fare riferimento alla dimensione effettiva.)

### Paso 4

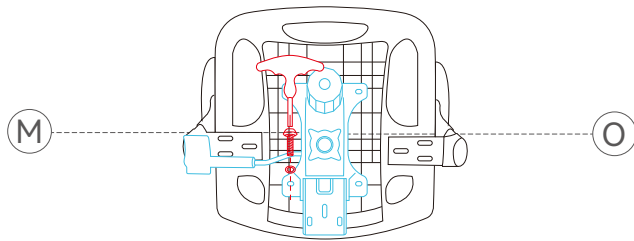

Fissare il meccanismo al sedile con 4 pezzi di piccole dimensioni e 4 viti (M6\*20).

### Paso 5

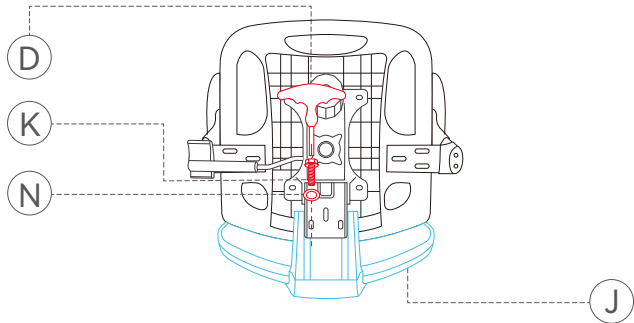

Fissare la piastra posteriore al sedile con 3 pezzi di grosso spessore e 3 viti (M8\*45).

### Paso 6



Metti il meccanismo nel sollevatore a gas.

### Paso 7

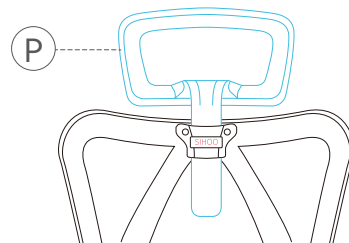

Inserte el reposacabezas en la ranura.



















### Istruzioni per la Sicurezza

1. Ogni sedia è progettata per sostenere il peso di una sola persona.
2. Si prega di utilizzare la sedia su una superficie piana e livellata.
3. Non permettere a bambini sotto i 5 anni di sedersi sulla sedia senza supervisione.
4. Evita di sederti sul bracciolo per prevenire potenziali incidenti.
5. Non stare in piedi sulla sedia, usarla come scala o calpestarla.
6. Si prega di astenersi dal mettere peso eccessivo sulla sedia o dall'usarla come carrello improvvisato.
7. Evita di utilizzare oggetti affilati o appuntiti che potrebbero danneggiare la sedia e mantenerla lontana da fiamme aperte o fonti di calore.
8. Per la tua sicurezza, non cercare di smontare il meccanismo di sollevamento a gas.

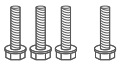

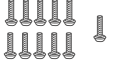
## Lista de piezas

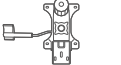
(Por favor, consulte el tamaño real. Cada tipo de tornillo y arandela tiene uno reservado como repuesto.)

Chiave	Descrizione	Parte	Qtà.	Di Ricambio
A	Rueda		5piezas	
B	Tubo de la pata de la silla		5piezas	
C	Base de conexión del tubo de la pata de la silla		1pieza	
D	Llave hexagonal		1pc	
E	Tornillo para patas de silla (M6*12)		10pcs	1pc
F	Pequeña calza		10pcs	1pc
G	Cubierta de ajuste de pie de silla		1pieza	
H	Elevador de gas		1pc	
I	Asiento		1pc	
J	Respaldo		1pc	
K	Tornillo de la placa posterior (M8*45)		3pcs	1pc
L	Reposabrazos		1pair	
M	Tornillo reposabrazos/Tornillo del mecanismo (M6*20)		10pcs	1pc
N	Gran cuña		4pcs	1pc
O	Mecanismo		1pc	
P	Reposacabezas		1pc	

Nota: Si prega di ordinare le viti e misurare in anticipo le loro lunghezze per facilitare l'assemblaggio.



## Instrucciones de ensamblaje

(Por favor, consulte el tamaño real.)

Scan for Video Guide



### Paso 1

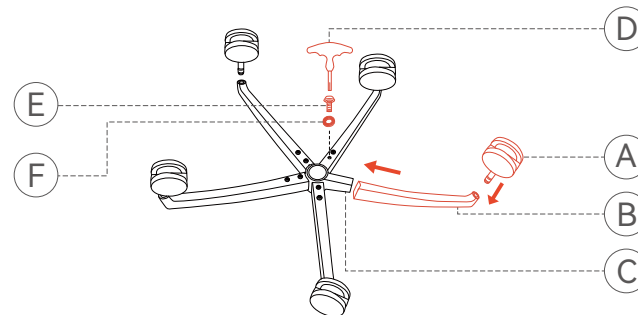

Use 10 tornillos de especificación M6\*12 para base de conexión del tubo de la pata de la silla y luego inserte las ruedas;

### Paso 2

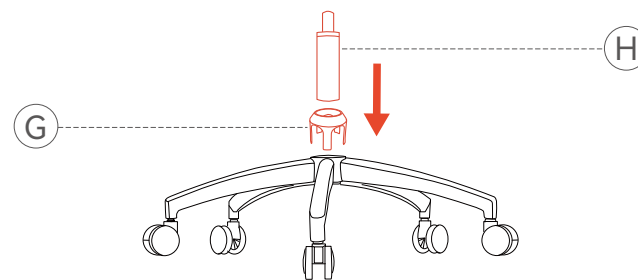

Primero, inserte la cubierta de la moldura del pie de la silla en el pie de la silla y luego coloque la varilla de presión de aire en el orificio central de la base de conexión del tubo de la pata de la silla;

### Paso 3

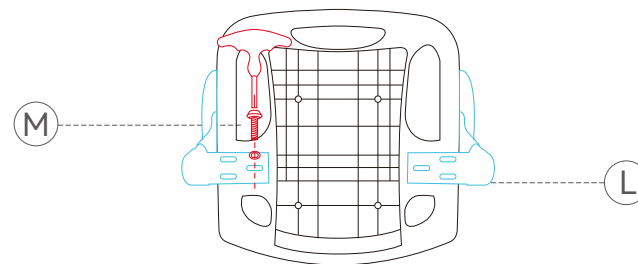

Fije el apoyabrazos al asiento con 6 piezas de calza pequeña y 6 tornillos (M6\*20).



## Instrucciones de operación

(Por favor, consulte el tamaño real.)

### Paso 4

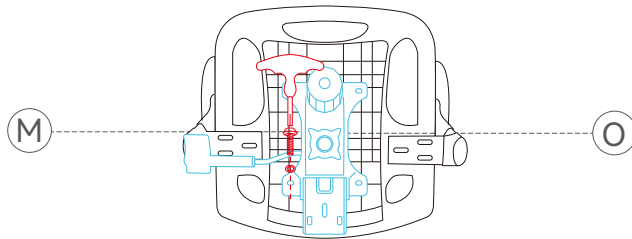

Fije el mecanismo al asiento con 4 piezas de calza pequeña y 4 tornillos (M6\*20).

### Paso 5

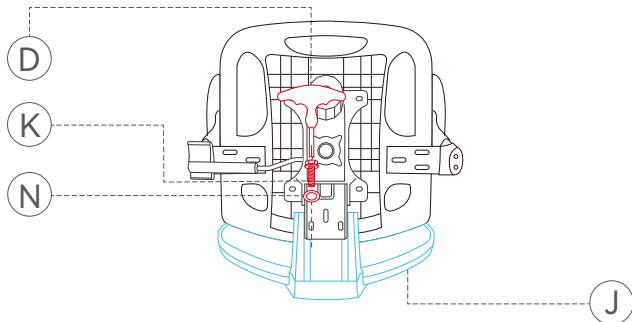

Fije la placa posterior al asiento con 3 piezas de calza grande y 3 tornillos (M8\*45).

### Paso 6

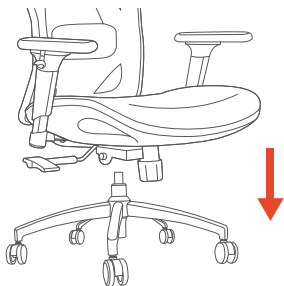

Coloque el mecanismo en el elevador de gas.

### Paso 7

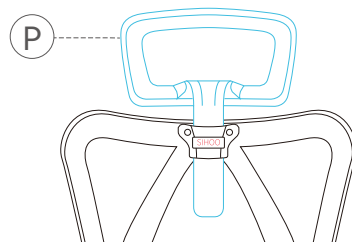

Inserte el reposacabezas en la ranura.



### Instrucciones de Seguridad

1. Cada silla está diseñada para soportar el peso de una sola persona.
2. Por favor, utilice la silla sobre una superficie plana y nivelada.
3. No permita que niños menores de 5 años se sienten en la silla sin supervisión.
4. Evite sentarse en el reposabrazos para prevenir posibles accidentes.
5. No se pare en la silla, úsela como escalera o pise sobre ella.
6. Por favor, absténgase de colocar un peso excesivo en la silla o utilizarla como un carrito improvisado.
7. Evite el uso de objetos afilados o puntiagudos que puedan dañar la silla, y manténgala alejada de llamas abiertas o fuentes de calor.
8. Para su seguridad, no intente desmontar el mecanismo de elevación a gas.



## 部品リスト

(実際のサイズをご参照ください。各種のねじとワッシャーは、それぞれ1つずつ予備として用意されています。)

キー	説明	部品	数	予備
A	ホイール		5個	
B	チェアレッグチューブ		5個	
C	チェアレッグチューブ接続ベース		1個	
D	六角レンチ		1個	
E	アームレストネジ/機構ネジ(M6*20)		10個	1個
F	小さなスペーサー		10個	1個
G	チェアフットリムカバー		1個	
H	ガススプリング		1個	
I	ベース		1個	
J	背もたれ		1個	
K	バックフレームネジ(M8*45)		10個	1個
L	アームレスト		1ペア	
M	チェアレッグスクリュー(M6 * 12)		10個	1個
N	大きなスペーサー		3個	1個
O	機械		1個	
P	ヘッドレスト		1個	

注意: 組み立てが容易になるように、事前にネジを分類して長さを測定してください。



## 組立手順書

(実際のサイズをご確認ください。)

ビデオガイド  
のスクリーン



### ステップ 1

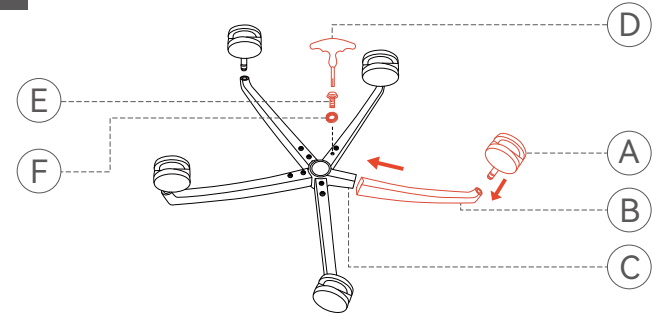

M6 \* 12仕様の10本のネジを使用して、5本のチェアレッグチューブをチェアレッグチューブ接続ベースに固定してから、ホイールを挿入します。

### ステップ 2

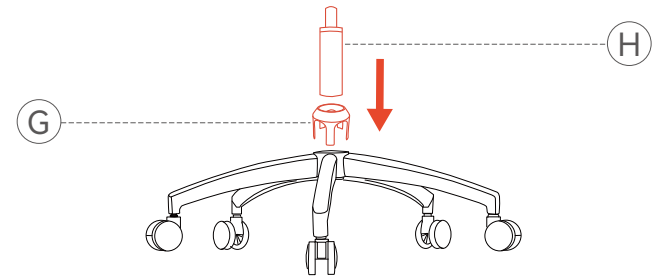

まず、チェアフットリムカバーをチェアフットに挿入し、次にエアプレッシャーロッドをチェアレッグチューブ接続ベースの中央の穴に挿入します。

### ステップ 3

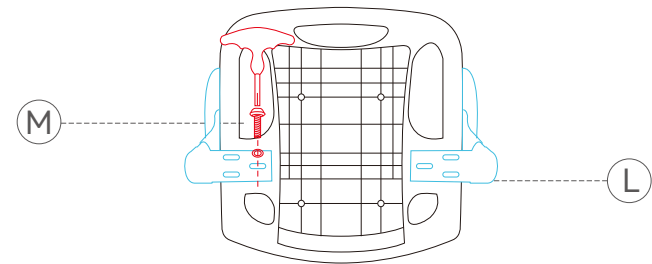

六本の M6\*20 のネジと小さいスペーサーにてシートクッションとアームレストを接続してください。左右の区別をご確認ください。



## 操作手順書

(実際のサイズをご確認ください。)

### ステップ 4

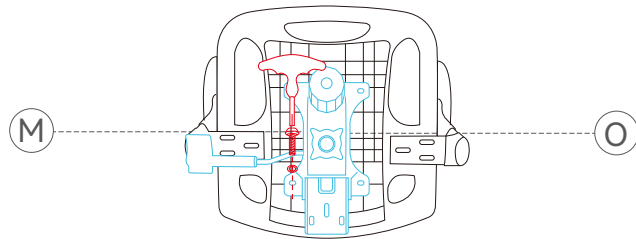

四本のM6\*20のネジと小さいスペーサーにてシートクッションと機構を接続してください。

### ステップ 5

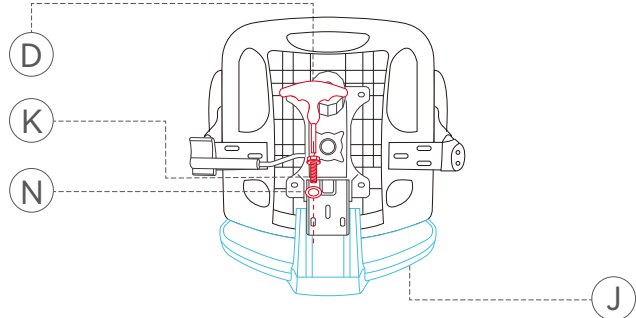

3本のM8\*45ネジと大きいスペーサーにてスチールプレートとシートクッションを接続してください。

### ステップ 6



組み立てた椅子の上部をガススプリングに合わせて入れてください。

### ステップ 7

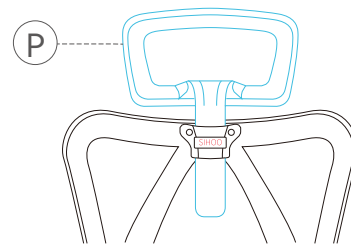

ヘッドレストを背もたれに挿入したら、その取り付けが完了です。

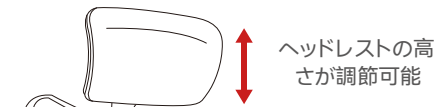

ヘッドレストの高さが調節可能

ボタンを上引くと、手すりの高さを調整できる。手すりの表面は自分の好みによって前後、左右を調整できる。

ウエストピローの前後と高さが調整可能

レバーを下に押す、椅子の高さを調整できる。レバーを外側に引き出すと、傾斜角度を選択できる。

レバーを内側に押すと角度がロックされる。後ろ向き角度は3つの段階がある。

後ろ向き弾力調節+締める-緩む



### Instrucciones de Seguridad

1. Cada silla está diseñada para soportar el peso de una sola persona.
2. Por favor, utilice la silla sobre una superficie plana y nivelada.
3. No permita que niños menores de 5 años se sienten en la silla sin supervisión.
4. Evite sentarse en el reposabrazos para prevenir posibles accidentes.
5. No se pare en la silla, úsela como escalera o pise sobre ella.
6. Por favor, absténgase de colocar un peso excesivo en la silla o utilizarla como un carrito improvisado.
7. Evite el uso de objetos afilados o puntiagudos que puedan dañar la silla, y manténgala alejada de llamas abiertas o fuentes de calor.
8. Para su seguridad, no intente desmontar el mecanismo de elevación a gas.



فحص لدليل الفيديو

تعليمات التجميع  
يرجى الرجوع إلى الحجم الفعلي.



# دليل المستخدم

## قائمة الأجزاء



يرجى الرجوع إلى الحجم الفعلي. يوجد مسمار واحد وغسالة واحدة محجوزة كاحتياطي لكل نوع.

1

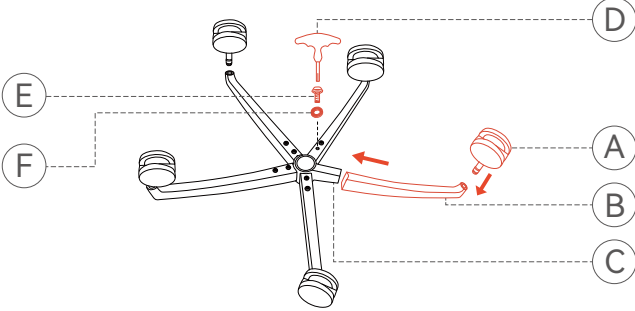

استخدم 10 مسمار من مواصفات M6\*12 لتثبيت أنابيب أرجل الكرسي الخمسة بقاعدة توصيل أنبوب ساق الكرسي ثم أدخل العجلات؛

2

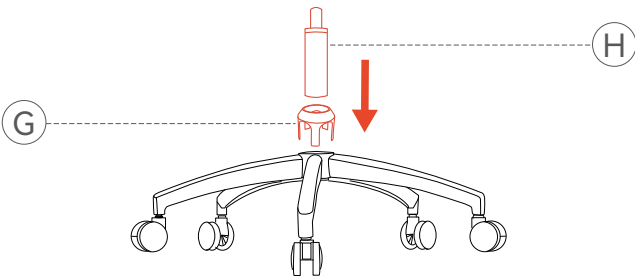

أولاً، أدخل غطاء تقليم قدم الكرسي في قدم الكرسي، ثم ضع قضيب ضغط الهواء في الفتحة الوسطى لقاعدة توصيل أنبوب ساق الكرسي؛

3

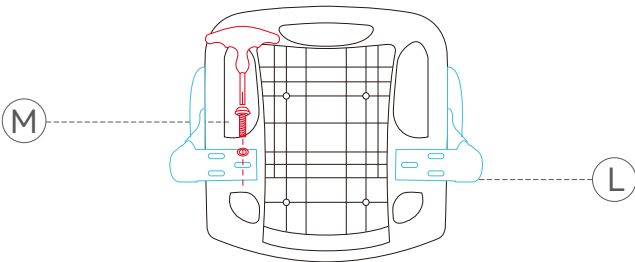

ثبت مسند الذراع على وسادة المقعد برفاقة صغيرة 6 قطع و 6 قطع (M6\*20) مسمار.

المفتاح	الوصف	الجزء	الكمية	الاحتياطي
A	عجلات		1	
B	كرسي أنابيب الساق		1	
C	قاعدة اتصال أنبوب الساق الكرسي		1	
D	عرافة وجع		1	
E	برغي ساق الكرسي (M6*12)		10	1
F	شليم صغير		10	1
G	كرسي غطاء تقليم القدم			
H	شريط هوائي		1	
I	وسادة المقعد		1	
J	ظهر المقعد		1	
K	المسمار لوحة الظهر (M8*45)		10	1
L	مساند الذراعين		1	
M	برغي مسند الذراع/برغي آلية (M6*20)		10	1
N	شليم كبير		10	1
O	آلية		1	
P	مسند الرأس		1	

ملاحظة: يرجى ترتيب المسامير وقياس أطوالها مسبقاً لتسهيل عملية التجميع.





### تعليمات السلامة

1. تم تصميم كل كرسي لدعم وزن شخص واحد فقط.
2. يرجى استخدام الكرسي على سطح مستوي ومستوي.
3. لا تسمحوا للأطفال دون سن الخامسة بالجلوس على الكرسي دون إشراف.
4. تجنبوا الجلوس على مسند الذراعين لتجنب وقوع حوادث محتملة.
5. لا تقفوا على الكرسي، استخدامه كسلم، أو وضع القدم عليه.
6. يرجى تجنب وضع وزن زائد على الكرسي أو استخدامه كعربة مؤقتة.
7. تجنب استخدام الأشياء الحادة أو المدببة التي يمكن أن تلحق ضرراً بالكرسي، واحتفظ به بعيداً عن اللهب المكشوف أو مصادر الحرارة.
8. من أجل سلامتكم، لا تحاولوا تفكيك آلية رفع الغاز.

4

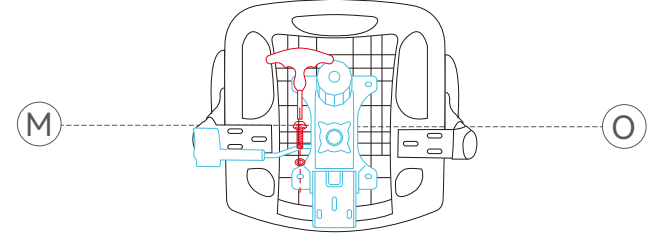

ثبت الآلية على وسادة المقعد برفاعة صغيرة 4 قطع ومسامير 4 قطع (M6\*20).

5

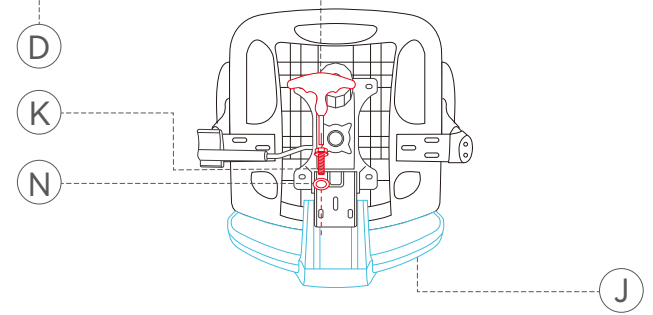

ثبت اللوحة الخلفية على وسادة المقعد بمسامير 3 قطع كبيرة و 3 قطع (M8\*45).

6

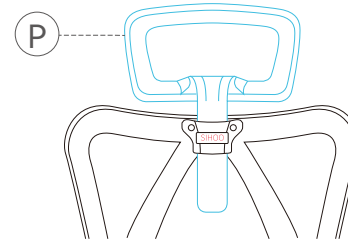

أدخل مسند الرأس في الفتحة.



ضع الآلية في الرفاعة الغازية.

### 1. Gasfeder - Sicherheitshinweis

Die Gasfedereinheit darf von Laien montiert werden.

Achtung: Arbeiten an und Austausch der Gasdruckfeder sind nur durch eingewiesenes Fachpersonal auszuführen.

### 2. Verstellung der Rückenlehne

Sie können den Gegendruck Ihres Gewichts unter der Rückenlehne nur einstellen, wenn die Rückenlehne unter Druck steht.

### 3. Sitzhöheverstellung (9 CM)

Die Sitzhöhe Ihres Drehstuhls lässt sich durch eine Gasdruckfeder stufenlos in der Höhe verstellen. Ziehen Sie dazu den Hebel unter dem Sitz rechts nach oben: die Sitzhöhe lässt sich verstellen. Wenn Sie den Sitz entlasten, geht der Sitz nach oben. Bei Belastung geht der Sitz nach unten. Hebel loslassen: Sitzhöhe ist fixiert.

Tipp: Sie sitzen richtig, wenn Ober- und Unterschenkel einen Winkel von etwa 90 Grad bilden.

### 4. Neigungverstellung der Körperlehne (110-116-126°)

Die Körperlehneneinstellung (Zugkraft der Rückenlehne) wird schnell über den Hebel rechts unter dem Sitz verstellt. Hebel nach außen: die Entriegelung der Rückenlehne. Hebel nach innen drücken: Die Lehneneigung ist verriegelt. Achtung: Wenn die Rückenlehne verriegelt ist, ist ein gewisser Druck erforderlich, um die Verstellung zu lösen (Nur wenn kein Rückenlehnendruck vorhanden ist).

### 5. Verstellung der Lordose Stütze (optional 5 CM)

Die Lendenwirbelstütze der Rückenlehne ist stufenlos höhen- und tiefenverstellbar (optional) und kann so optimal an die individuelle Rückenform des Nutzers, insbesondere im Lendenbereich, angepasst werden.

Um die Höhe einzustellen, drücken Sie das Lendenkissen der Rückenlehne mit beiden Händen gleichzeitig nach oben oder unten. Die Tiefe der Lendenwirbelstütze wird durch Drehen des Knopfes am Lendenwirbelkissen der Rückenlehne eingestellt.

Tipp: Die Vorwölbung der Lordose Stützung so wählen, dass Sie sich im Bereich der Lendenwirbel angenehm stabilisiert fühlen.

### 6. Nackenstütze (8 CM)

Die Nackenstütze besteht aus PA-Material und ist stufenlos höhenverstellbar. Zur Höheneinstellung schieben Sie die Nackenstütze nach oben oder unten.

Tipp: Beim Zurücklehnen muss Ihr Nacken durch die Nackenstütze komfortabel abgestützt werden.

### 7. Armlehnen/Armsupports (6 CM)

Die Höhe des Auslegers kann ohne Werkzeug eingestellt werden. Drücken Sie dazu den Bedienknopf unter der Armlehne und stellen Sie die Höhe der Armlehne ein. Die Oberfläche der Armlehne lässt sich nach vorne und hinten sowie nach links und rechts verstellen. Tipp: Die Armlehnen entlasten die Wirbelsäule, den Schultergürtel und die Armmuskulatur dann wirkungsvoll, wenn Ober- und Unterarm einen Winkel von etwa 90 Grad bilden.

### 8. Armlehnen/Armsupport (optional)

	Höhenverstellbare Armlehne
<b>Höhenverstellung</b>	7 cm

\* Bedienknopf an der Unterseite der Armlehne drücken, verstellen und fixieren Sie die Armlehne in die Höheposition.

<b>Normen/ Zertifikate Qualitätsgütesiegel</b>	Konstruktionsgrundlage der SIHOO Serie sind Normen und Anforderungsprofile zeitgemäßer Sitztechnik. Die SIHOO Serie ist SGS + TÜV Rheinland LGA Produkts GmbH geprüft und zertifiziert.
<b>EN Siegel</b>	EN 1335 -1/-2:2018 Büro-Arbeitsstuhl EN 16955:2017 Gasdruckfeder / EN 12529 Laufrollen
<b>Zertifikatssymbol</b>	Sicherheit für hohen ergonomischen Standard über EN hinaus
<b>Garantie</b>	Auf diesen Stuhl haben Sie 3 Jahre Garantie
<b>Wartung/Reinigung</b>	Alle mechanischen und beweglichen Teile sind wartungsfrei. Gelegentliches Säubern der Laufrollen von Teppichflusen ist ratsam. Für die Reinigung der Bezüge entfernen Sie zuerst den Staub. Flecken behandeln Sie mit einem weißen, weichen Tuch (keine Mikrofaser). Zuerst reinigen, dann pflegen. Sitz- und Rückbezüge der M57 Serie sind nutzerfreundlich wechselbar.

<b>Anwendung</b>	Dieser Bürodrehstuhl darf nur bestimmungsgemäß unter Beachtung der allgemeinen Sorgfaltspflicht und der Anleitung benutzt werden. Bei unsachgemäßem Gebrauch (z.B. Aufstiegshilfe, Sitzen auf den Armlehnen, extremen Belastungen) besteht Unfallgefahr.
<b>Rollen</b>	Serienausstattung mit Rollen für Teppichböden. Auf Wunsch weiche Räder für Hartböden, erkennbar am andersfarbigen Lauftring. Aus sicherheitstechnischen Gründen muss ein entsprechender Austausch der Rollen bei Wechsel von Teppich- auf Hartboden und umgekehrt erfolgen.
<b>Wichtiger Hinweis</b>	Gasfederaggregat nicht erhitzen und nicht gewaltsam öffnen! Arbeiten und Austausch an Gasfedern nur durch eingewiesenes Fachpersonal.
<b>Vertretung in Europa: MARWAY Consulting UG (haftungsbeschränkt)</b>	Am Maibusch 108 -110,45883, Gelsenkirchen, Germany Tel: 0049 17645084650 Email: MARWAYUG@outlook.com

# Help Center

## About Products:

- Q:** The backrest mesh is broken.  
**A:** Please contact us, and we will arrange the delivery of a replacement!
- Q:** The chair is too short for me.  
**A:** Please adjust it to the maximum height to see if it's suitable for you.  
If not, we recommend changing the gas lift.
- Q:** What if I receive a damaged or incorrect product?  
**A:** If you receive a defective, incorrect, or incomplete product, please contact us immediately and keep all items and packaging materials until your claim is resolved. If your replacement product is out of stock, we will notify you immediately of the estimated arrival date and work with you to suggest a suitable replacement product.
- Q:** I hear noises when sitting on the chair.  
**A:** Please check if all parts of the chair have been installed tightly. If not, there might be a problem with the mechanism, and we recommend you send us a video for further evidence first.
- Q:** Why would the armrest shake?  
**A:** Please check whether the screws are tightened enough first, then check the shaking of the armrest pad.
- Q:** The backrest shakes.  
**A:** The backrest might not be installed tightly. It's recommended to reinstall it first.
- Q:** There is an abnormal odor when the chair is taken out of the box.  
**A:** Please leave the chair in a well-ventilated room for 2-3 days before use.
- Q:** There are scratches or cracks in the backrest or other parts.  
**A:** We hope this does not affect the normal use of the chair, and you can consult us for the replacement of the flawed parts.
- Q:** There are missing parts in this order.  
**A:** In this case, please inform us which parts are missing along with your order number and provide us with a photo of all the parts you currently have. Then, we will report this to the factory and arrange the delivery or work with you to find a satisfactory solution.
- Q:** The chair makes me uncomfortable, but I cannot find where the problem is.  
**A:** We are sorry to hear that you are having an unsatisfactory user experience. Please kindly send us a photo or video of where the problem might lie. This way, we can better locate the issue and offer you a solution.

## About Delivery:

- Q:** What is the estimated delivery time?  
**A:** Home delivery within the continental U.S. usually takes 3-8 days.
- Q:** The product has not been delivered.  
**A:** We apologize for the inconvenience caused. Due to COVID-19, shipping may experience delays. Please be patient, and we will keep track of it with you.
- Q:** The product fails to be dispatched.  
**A:** Please contact us, and we will confirm your address again. Then we will report this to the DPD.
- Q:** The shipping information has not been updated.  
**A:** Due to a large quantity of orders, it might take some time before the information is fully updated. Your patience is highly appreciated.
- Q:** There are scratches or cracks in the backrest or other parts.  
**A:** We hope this does not affect the normal use of the chair, and you can consult us for the replacement of the flawed parts.

## About Orders:

- Q:** Can I cancel my order?  
**A:** For items that have not been delivered or items with delayed delivery, canceling the order will be accepted. Inventory items are usually shipped within 24-48 hours after an order is placed. Once the items are shipped, they cannot be canceled. \*Orders of customized or special items cannot be canceled.
- Q:** My order is lost during delivery.  
**A:** Please contact the responsible logistics center and provide them with detailed information for compensation. If you need any help concerning this, feel free to contact us.