

Owners Manual

HYDRAULIC

TRAIL-A-MATE Trade Mark

CARAVAN AND TRAILER JACK

WARNING

THIS PRODUCT IS ONLY TO BE
USED WITH THE TRAIL-A-MATE
ENGAGEMENT FITTING

**THE JOCKEY
WHEEL
THAT CONVERTS
TO A JACK!**

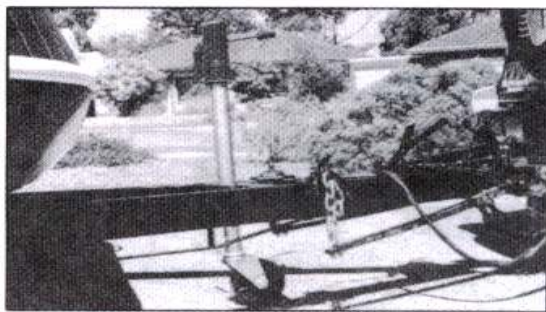

PLEASE FAMILIARISE YOURSELF WITH THIS MANUAL BEFORE USING TRAIL-A-MATE
TO PREVENT DAMAGE TO PROPERTY OR PERSONAL INJURY.

THIS PRODUCT IS MANUFACTURED TO AS/ NZ STANDARDS 2693:2007

WORKING LOAD LIMIT 1000KG

IMPORTANT

Sometimes during shipping and handling, air may get trapped in the hydraulic system, causing poor or no lifting performance. Purge any air from the system by simply opening the release valve (turn counter-clockwise) and unscrew the air vent valve (turn counter-clockwise) then operate pump handle several times. Once this is done tighten air vent valve (DO NOT OVER TIGHTEN O-RING) and close release valve.

HOW TO USE YOUR HYDRAULIC JOCKEY WHEEL

1. The base plate must be fitted in order to lift the Working Load Limit 1000kg.
2. Turn release valve clockwise and use end of handle to raise by pumping.
3. To lower the jockey wheel, turn the release valve slowly counter-clockwise.
4. All the components and seals are easily replaceable.



CAUTION

LIABILITY WILL NOT BE ACCEPTED IF JOCKEY WHEEL IS LEFT
FITTED TO CARAVAN / TRAILER WHILE TRAVELLING

CAUTION

NO PERSON SHOULD PLACE ANY PORTION OF THEIR BODY UNDER A CARAVAN / TRAILER THAT IS SUPPORTED ONLY BY A JACK. USE VEHICLE SUPPORT STANDS

HOW TO CONVERT HYDRAULIC JOCKEY WHEEL INTO A JACK

1. You **MUST REMOVE** wheel and fit base plate to use as a jack.
2. Fit lifting clamp to outer shaft cover (Between or over lugs) opposite side of release valve and jack handle linkage.
3. Make sure lifting clamp handle is done up tight.
4. Position jack along side the vehicle so that the slot in saddle is centered below the Trail-A-Mate engagement fitting on caravan.
5. Make sure release valve is tightened clock-wise and pump handle until slot in saddle is locked into the Trail-A-Mate engagement fitting.
6. Continue to raise jack to desired height.
7. When finished, remove support stands and then slowly turn release valve counter-clockwise to lower vehicle.

Minimum Height of Trail-A-Mate: 145mm

Maximum Height of Trail-A-Mate: 780mm

Maximum Lifting Range: 380mm

Working Load Limit: 1000kg

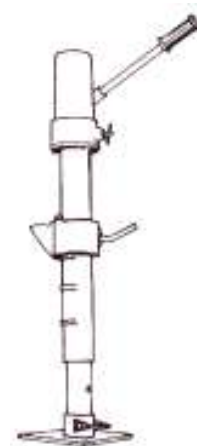

IMPORTANT WARNING

PLEASE READ INSTRUCTIONS THOROUGHLY

Before using your jack, you should ensure the following

**THE JACK SHOULD BE USED
ONLY WITH THE TRAIL-A-MATE
ENGAGEMENT FITTING**

1. That the jack should be used on level firm ground wherever possible.
2. That it is recommended that the wheels of the caravan / trailer be chocked, and that no person should remain in a caravan / trailer that is being jacked.
3. The caravan / trailer should be attached to the towing vehicle.
4. No person should place any portion of their body under a caravan / trailer that is supported only by a jack.

**NO PERSON SHOULD REMAIN
IN A CARAVAN / TRAILER THAT IS
BEING JACKED.**

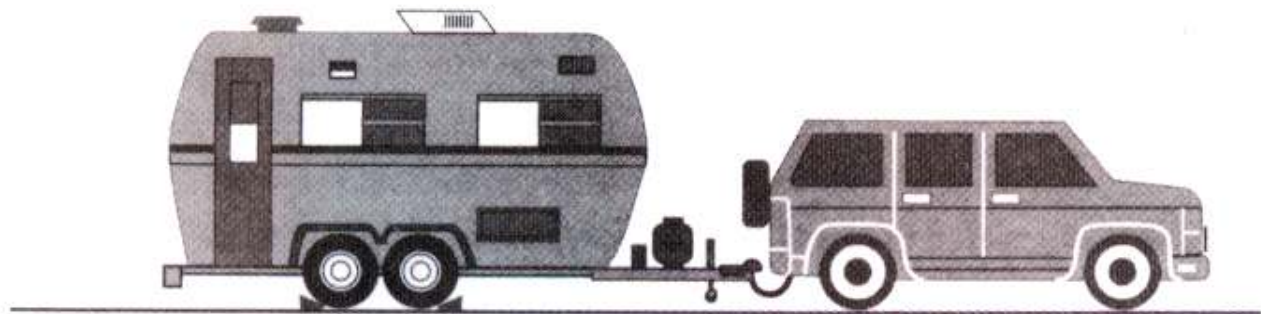

FITTING INSTRUCTIONS

for Trail-A-Mate engagement fitting

Weld Trail-A-Mate Jack engagement fitting to the bottom of the cross-member at the REAR of the axle keeping flush to outside wall of caravan

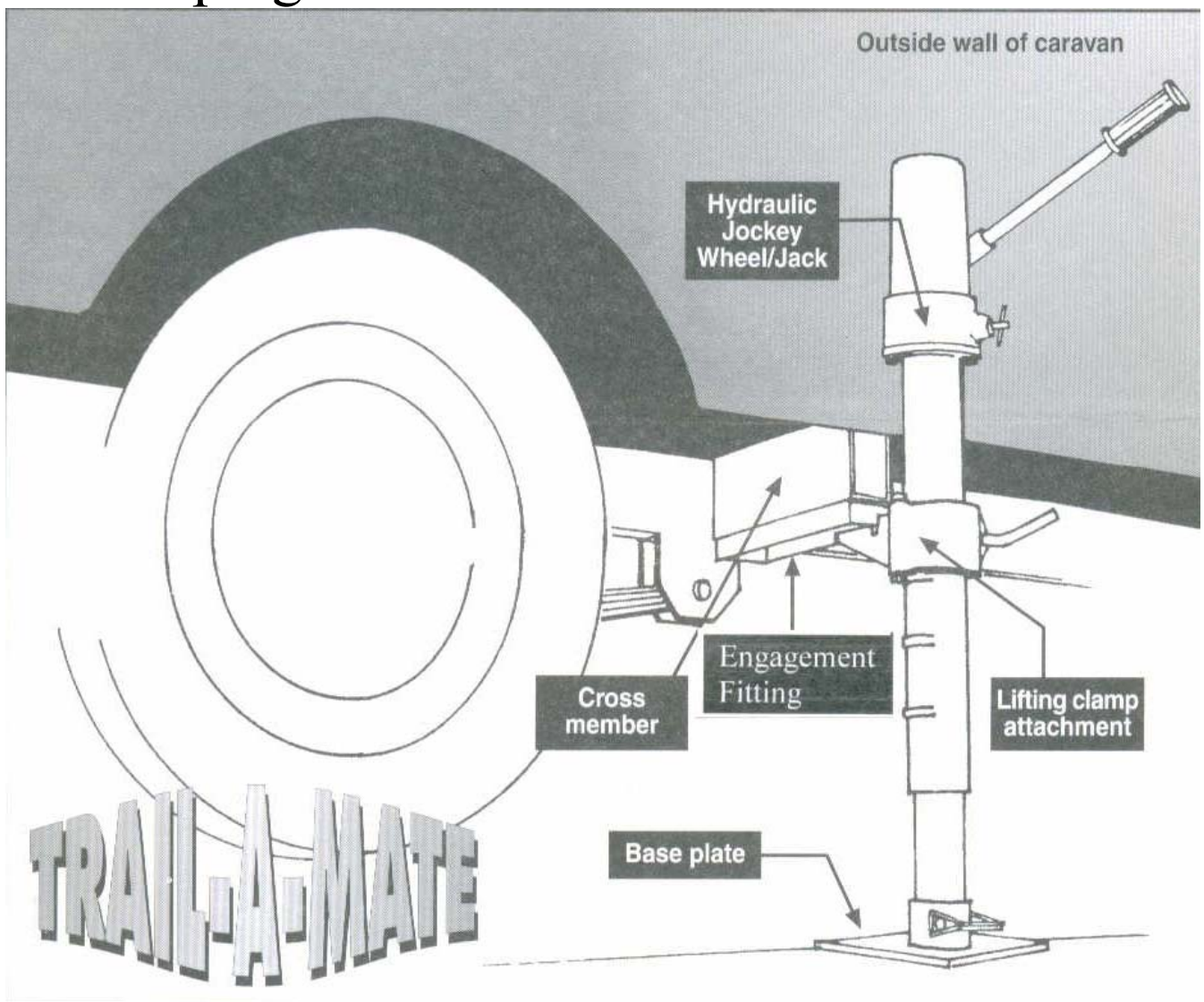

IMPORTANT: PLEASE NOTE

Some older model caravans need to have cross-member at rear of axle strengthened to accommodate engagement fitting

1. TERRAIN CHOOSING

The jack should be used on firm level ground where ever possible.

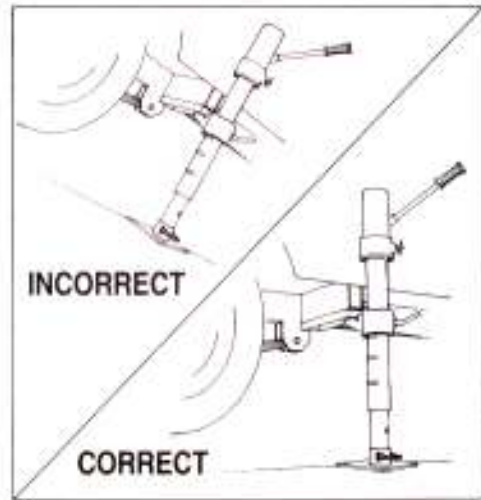

2. PROPER POSITIONING

The jack should be positioned under the Trail-A-Mate engagement fitting. This MUST be located on the cross-member at the REAR of the axle.

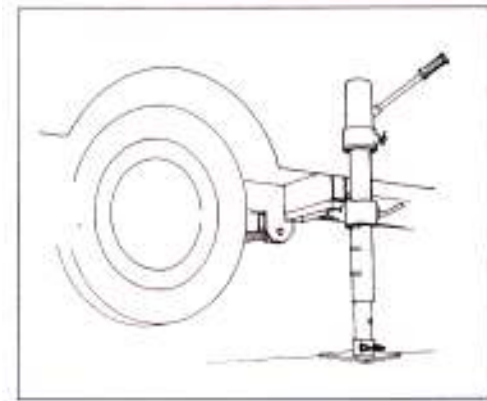

3. WORKING UNDER THE VEHICLE

The jack should be used for lifting and lowering only. The raised caravan / trailer should be supported on vehicle support stands.

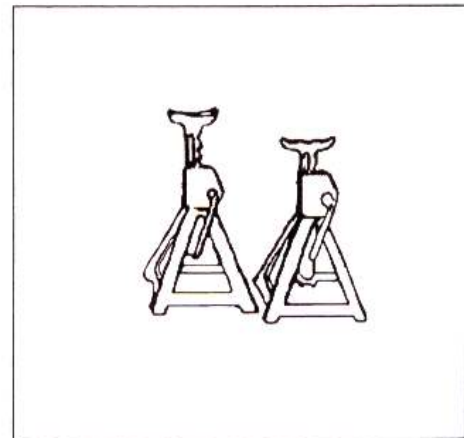

**NO PERSON SHOULD GET UNDER
A CARAVAN / TRAILER THAT IS
SUPPORTED ONLY BY A JACK**

MAINTENANCE PRODECURES

For better performance and longer life the oil level should be maintained at 20mm below the top of the oil reservoir.

ADDING OIL

With the jack fully lowered and the release valve closed, remove the air vent valve (Part # 23) being very careful not to permit dirt or foreign matter to get into the hydraulic system. Use only a good quality HYDRAULIC JACKING OIL (Preferably Grade 32). Fill the reservoir until it is 20mm below the top of the reservoir. Replace air vent valve (Part #23) and be careful not to over tighten O-Ring.

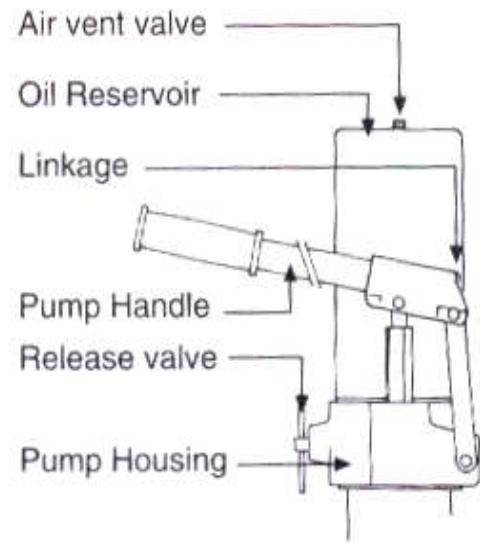

PREVENTING RUST

Check piston rod and pump every three months for any signs or rust or corrosion. Clean as needed and wipe with an oily cloth. When not using the jack, always leave the saddle and pump piston all the way down and make sure the release valve is closed.

IMPORTANT

DO NOT USE brake fluid, glycerin detergent, engine or dirty motor oil as improper fluid will cause serious internal damage.

TROUBLE SHOOTING (Using within rated load capacity)

TROUBLE	POSSIBLE CAUSE	REMEDY
Will not lift load at all.	<ol style="list-style-type: none"> 1. Release valve not closed. 2. Air in hydraulic system. 3. Check Valve not functioning. 	<ol style="list-style-type: none"> 1. Turn release valve clockwise tightly. 2. Open release valve and air vent valves and pump handle several times. (refer to top of page 2) 3. Change the check valve.
Will lift the load only part way.	<ol style="list-style-type: none"> 1. Oil level low. 2. The reservoir could be over filled. 	<ol style="list-style-type: none"> 1. Fill to prescribed level. 2. Remove oil until 20mm below top of reservoir.
Will lift load but not hold.	<ol style="list-style-type: none"> 1. Release valve not closed. 2. Check valve worn or defective. 	<ol style="list-style-type: none"> 1. Tighten release valve clockwise. 2. Change the check valve.
Jack will not lower.	<ol style="list-style-type: none"> 1. Unit needs lubrication. 2. The jack could be air blocked. 	<ol style="list-style-type: none"> 1. Oil external moving parts. 2. Open release valve and the air vent valve and pump handle several times.
Poor lifting.	<ol style="list-style-type: none"> 1. Defective pump and/ or valve malfunction. 2. Dirty oil. 3. Air in hydraulic system. 	<ol style="list-style-type: none"> 1. Change the check valve. 2. Change the hydraulic oil. 3. Purge air from the system.

TRAIL-A-MATE PARTS LIST

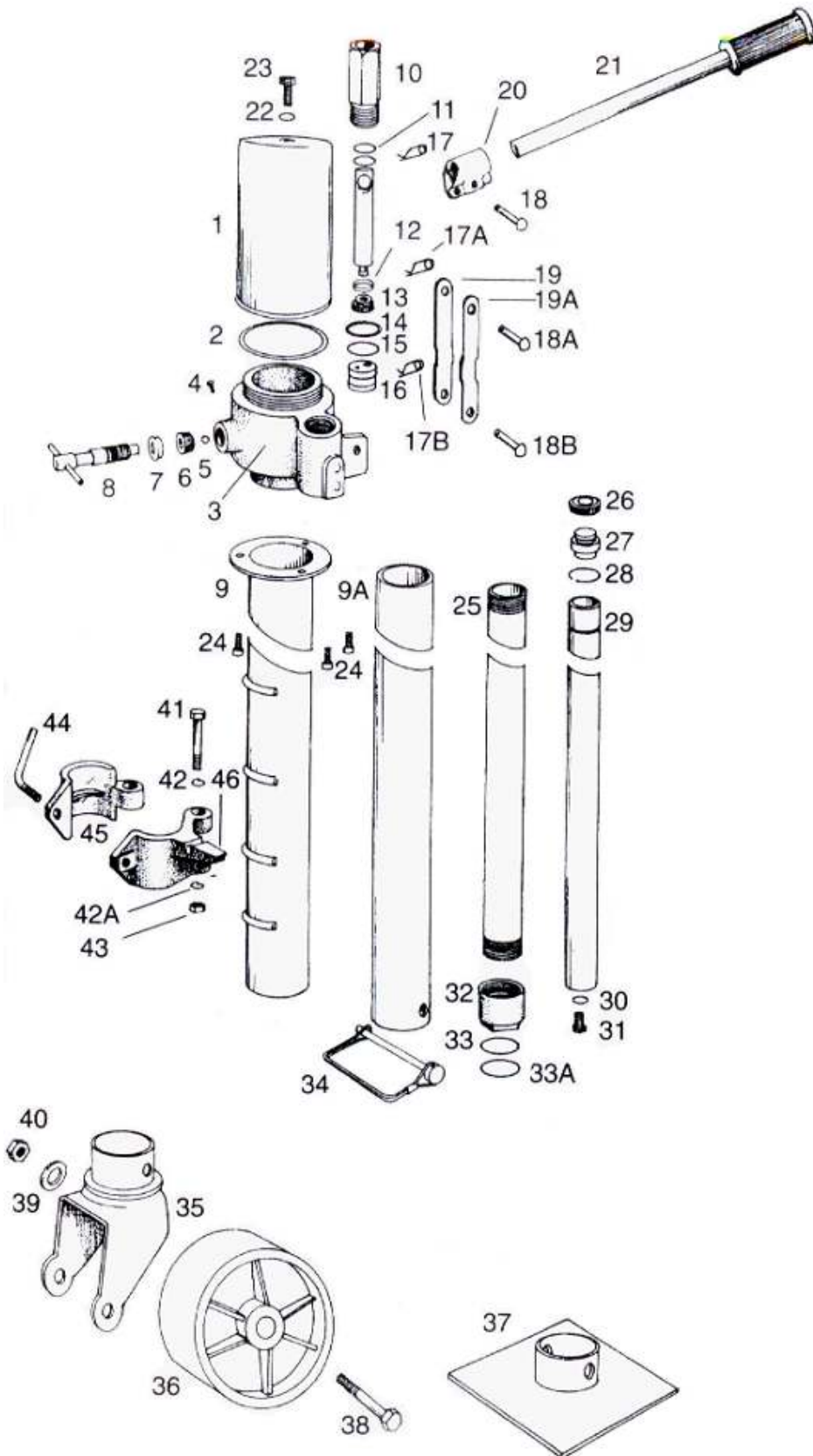

- 1 OIL RESERVOIR
- 2 O-RING
- 3 PUMP HOUSING
- 4 SCREW
- 5 BALL BEARING
- 6 SEAL
- 7 SEAL COVER
- 8 RELEASE VALVE
- 9 OUTER SHAFT COVER
- 9A INNER SHAFT COVER
- 10 PISTON HOUSING
- 10A PISTON
- 11 PISTON SEALS
- 12 COLLAR
- 13 SEAL
- 14 O-RING
- 15 O-RING
- 16 CHECK VALVE
- 17.17A.17B SNAP PINS
- 18.18A.18B LINKAGE PINS
- 19.19A LINKAGES
- 20 JACK HANDLE LINKAGE
- 21 PUMP HANDLE
- 22 O-RING
- 23 AIR RELEASE VALVE
- 24 ALLEN KEY STUDS (3)
- 25 SHAFT HOUSING
- 26 SEAL
- 27 SEAL COVER
- 28 COLLAR
- 29 MAIN SHAFT
- 30 SPRING WASHER
- 31 BOLT
- 32 SHAFT COLLAR
- 33.33A SHAFT SEALS
- 34 WHEEL LOCATING PIN
- 35 WHEEL HOUSING ASSEMBLY
- 36 WHEEL
- 37 BASE PLATE
- 38 WHEEL AXLE
- 39 SPRING WASHER
- 40 AXLE NUT
- 41 BOLT
- 42.42A SPRING WASHERS
- 43 NUT
- 44 LIFTING CLAMP HANDLE
- 45 LIFTING CLAMP
- 46 LIFTING SADDLE

HYDRAULIC
TRAIL-A-MATE Trade Mark
CARAVAN AND TRAILER JACK

Seatra International Pty Ltd
233 Shepherds Hill Road, Eden Hills, S.A. 5050
Phone: (08) 8278 5107 Fax: (08) 8278 9269
Website: www.trail-a-mate.com.au
Email: seatra@iweb.net.au

This product is tested by:
Melbourne Testing Services
NATA Accreditation No. 1047

