

# CLOTHES RACK

## ASSEMBLY INSTRUCTIONS

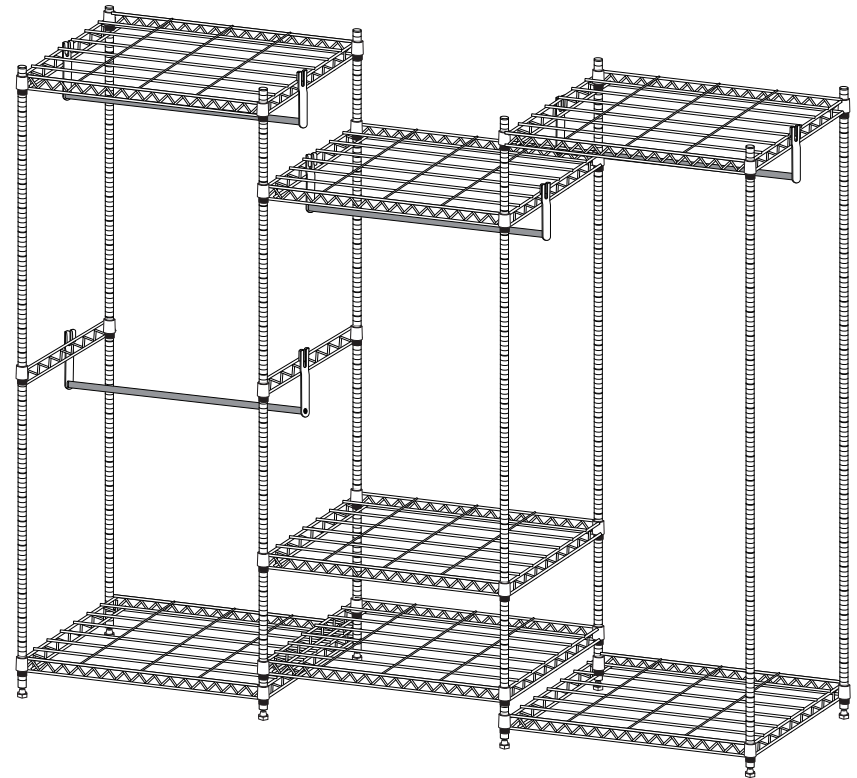

Please check all parts and accessories according to the parts list before assembling, make sure all contents are sufficient and in good condition.

If there is any parts missing or defective, please contact us immediately with purchase platform message to get replacement parts.

**Please Notice:**

1. Part **J** is used as a group (2PCS in a group). Multiple clearances existing between 2 plastic clips when they have been attached to the poles are not indicative of any quality issue but rather a structural design based on the physical law of thermal expansion and contraction, which is intended to make the metal Steel Shelves firmly fastened to the poles.
2. For easier assembly, please strictly follow the order of steps below.
3. When assembling, please avoid fingers being pinched.
4. Please **DO NOT** load more than the maximum weight described on the product page.

## PARTS:

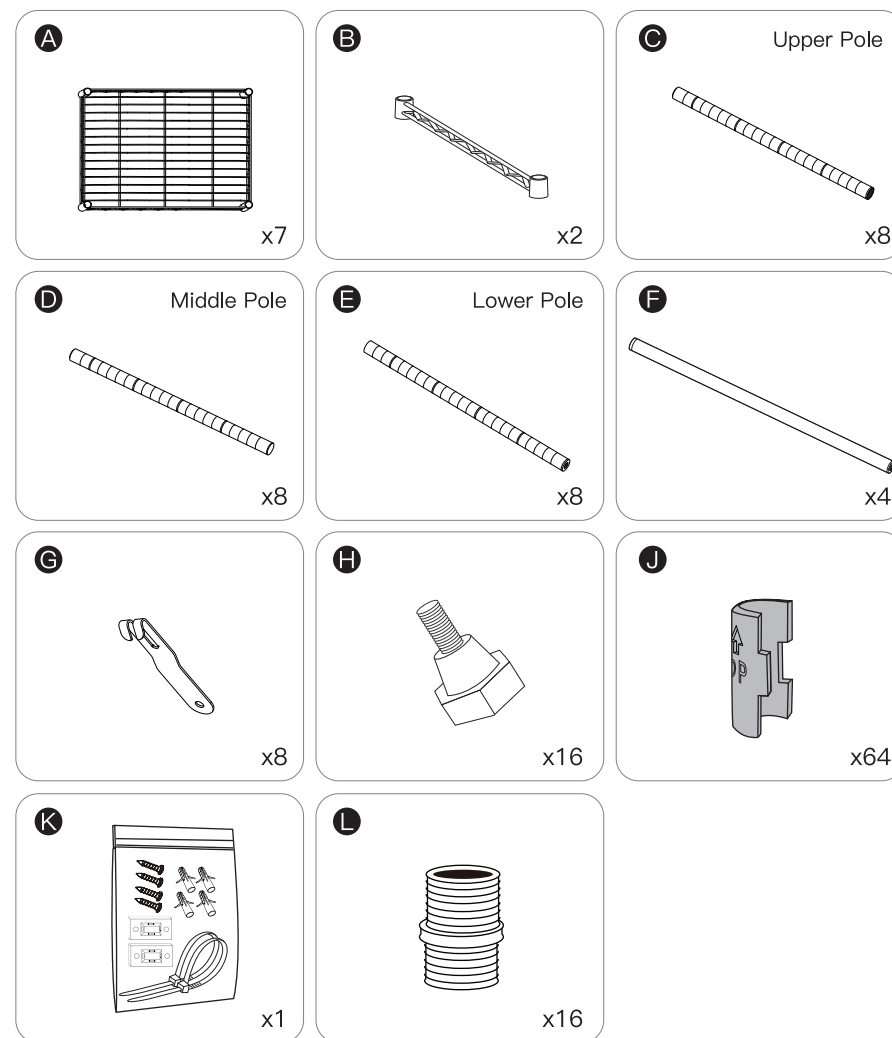

# HOW TO INSTALL

**Step 1** Install part **H** into part **E**.

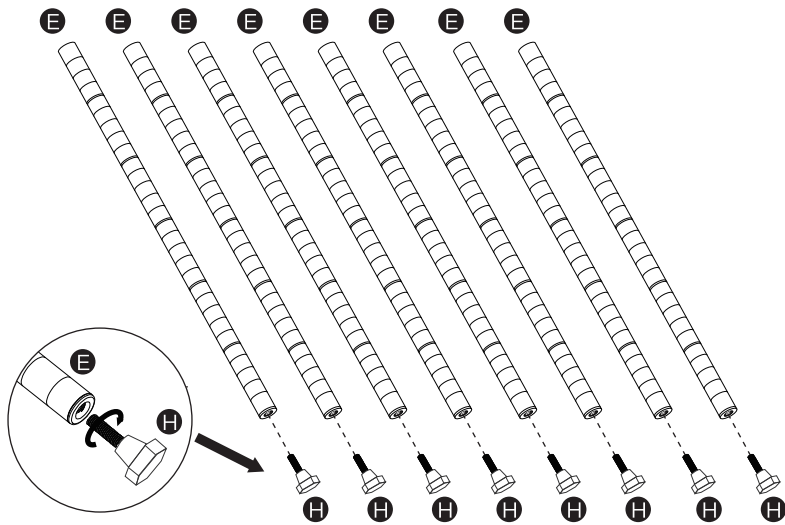

**Step 2** Learn to install clips **J** to poles.

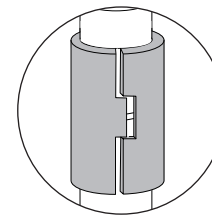
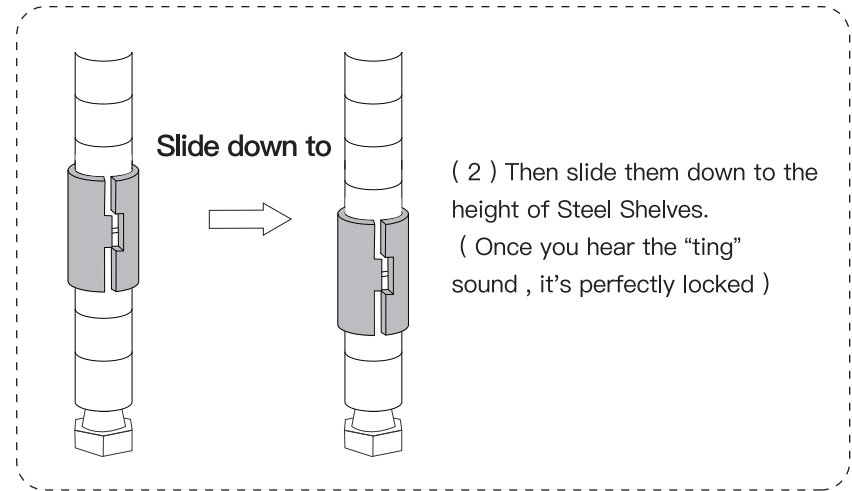
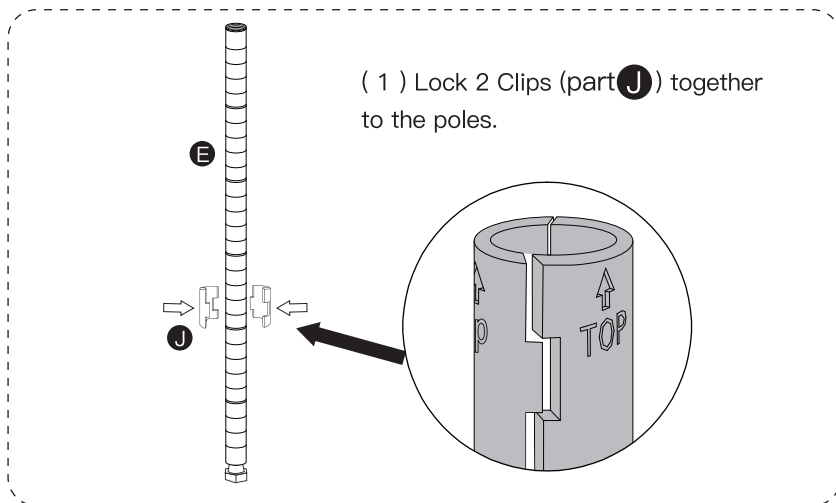

**Note:**

There is a gap between 2PCS plastic clips when assembled onto the poles as shown in the picture, this is a structural design rather than a quality issue, which aims to bind the shelves firmly onto the pole.

**Step 3** Lock clips as below, and install part **A** to part **E**.

( 1 ) Lock Clips (part **J**) on each Lower Pole (part **E**).

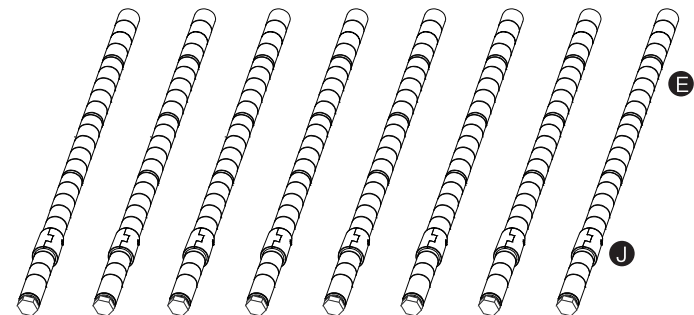

( 1 ) Install 2 Steel Shelves (part **A**) onto the Clip groups on Lower Pole.

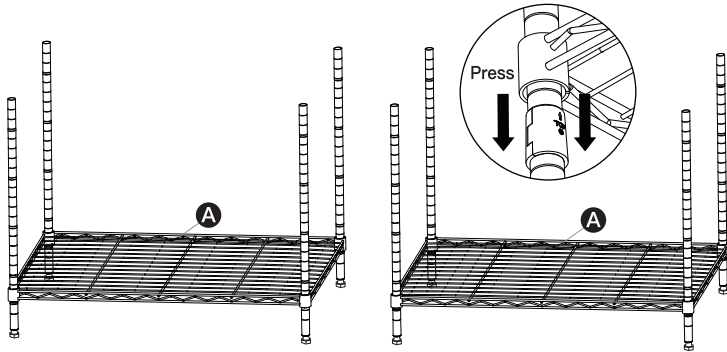

**REMARK:**

After each shelf is assembled, please put a piece of cloth on it and hit it several times with a tool(eg. A rubber mallet) to ensure more stability.

**Note:**

The rubber mallet is not included in the package.

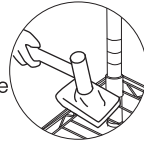

**Step 4** Install part **A** to part **E**.

( 1 ) Lock Clips (part **J**) as below.

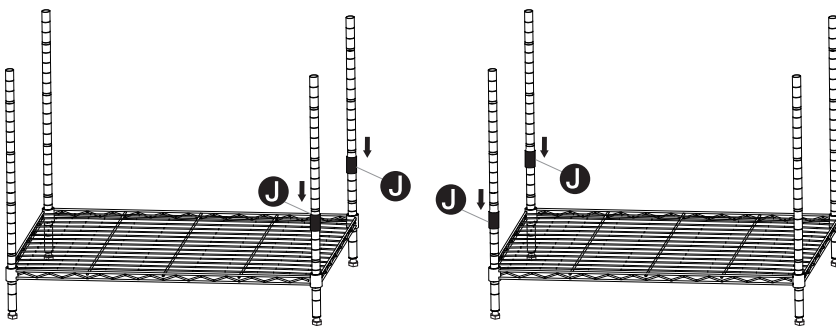

( 2 ) Install the Steel Shelves (part **A**) onto the Clip groups.

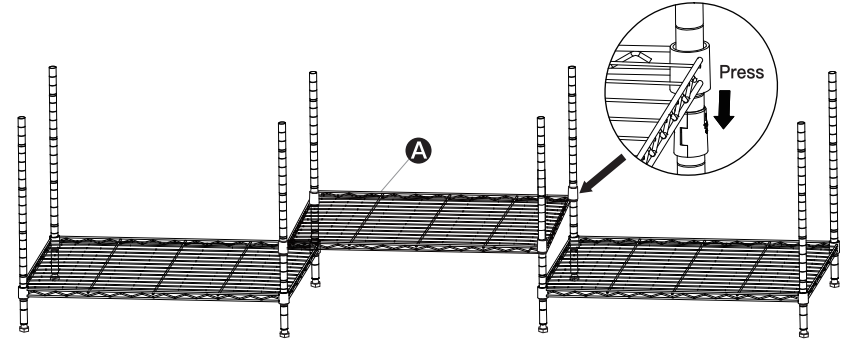

**Step 5** Install part **L** to part **D**.

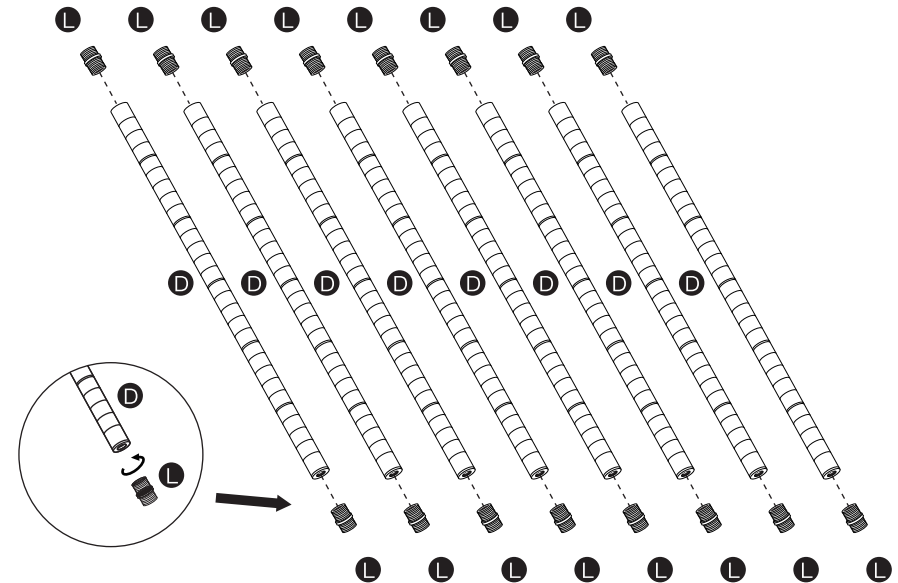



**Step 6** Install part **D** on part **E**.

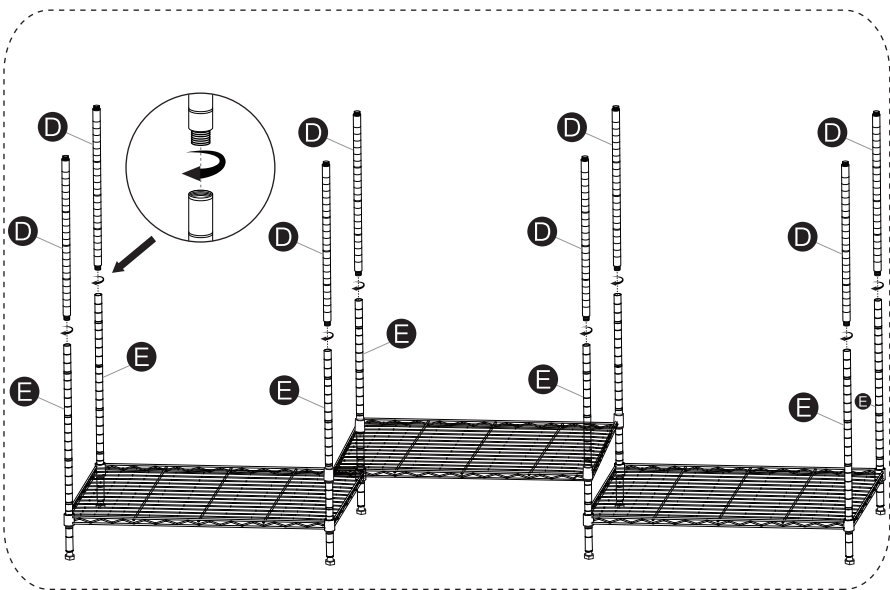

**Step 7** Lock clips and install part **B** and part **A** to part **D**.

( 1 ) Lock Clips ( part **J** ) as below.

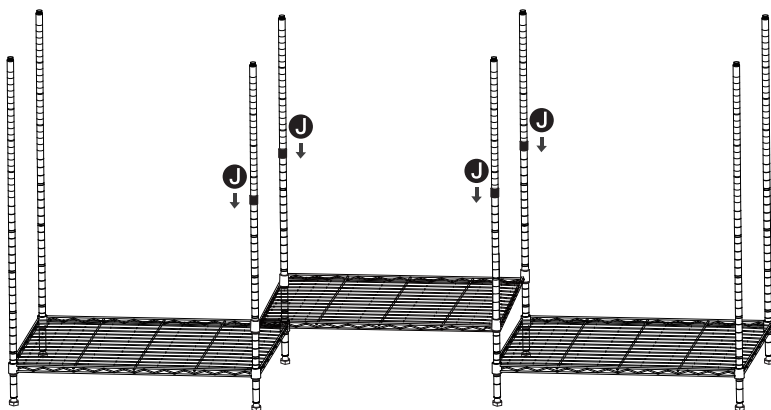

( 2 ) Install the Steel Shelves ( part **A** ) onto the Clip groups.

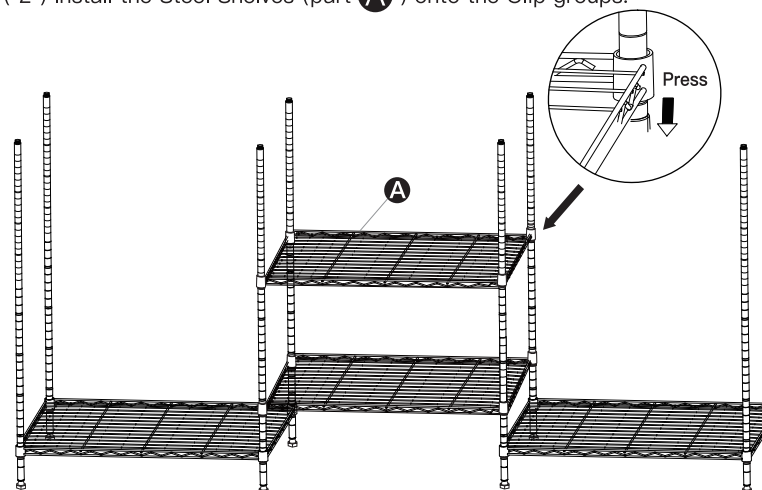

( 3 ) Lock Clips ( part **J** ) as below.

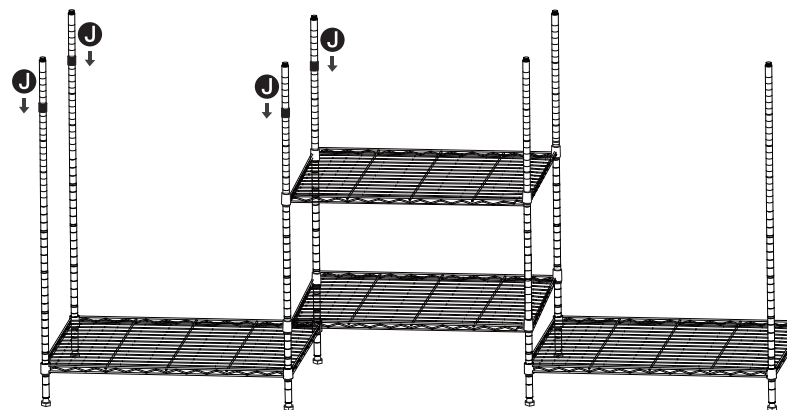

( 3 ) Install the Side Rod ( part **B** ) onto the Clip groups .

**Notice:**

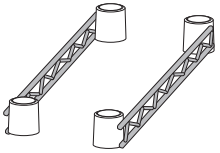

The side rod ( part **B** ) must be installed as showed above.

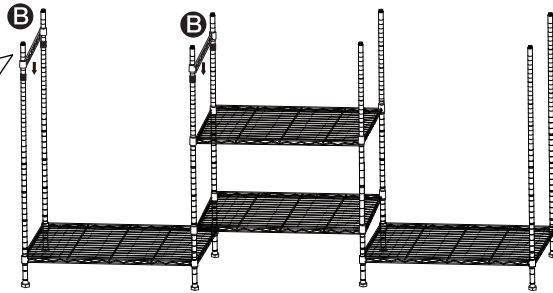

**Step 8** Install part **C** to part **D**.

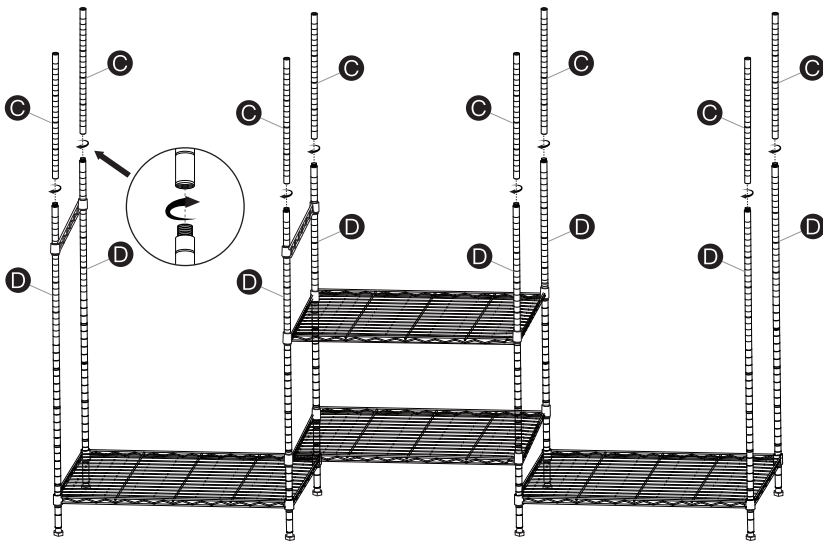

**Step 9** Lock clips and install part **A** to part **C**.

( 1 ) Lock Clip ( part **J** ) as below.

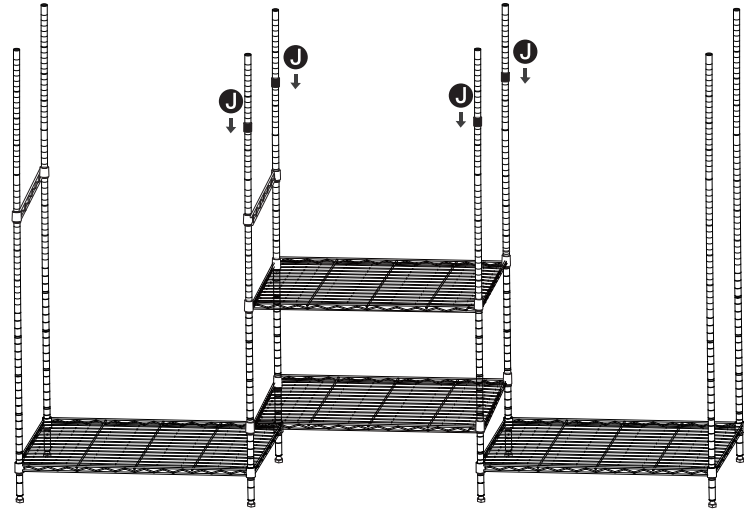

( 1 ) Install the Steel Shelves ( part **A** ) onto the Clip groups.

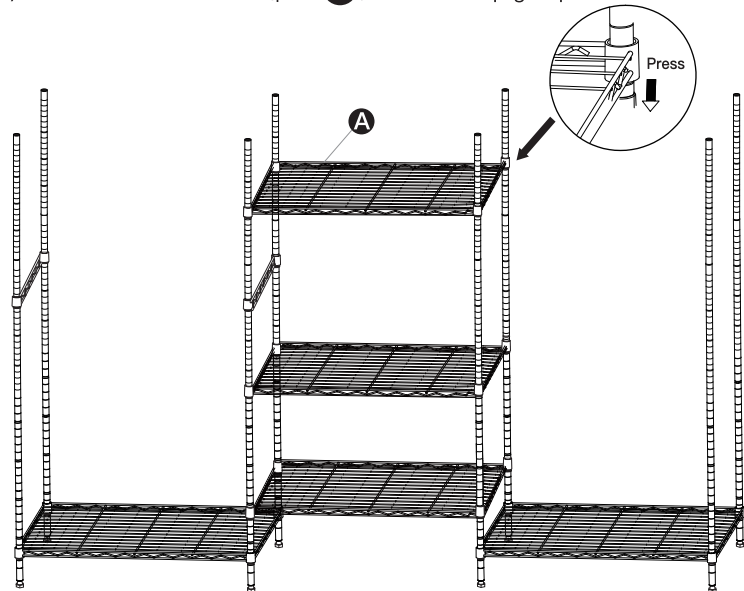

( 3 ) Lock Clip ( part **J** ) as below.

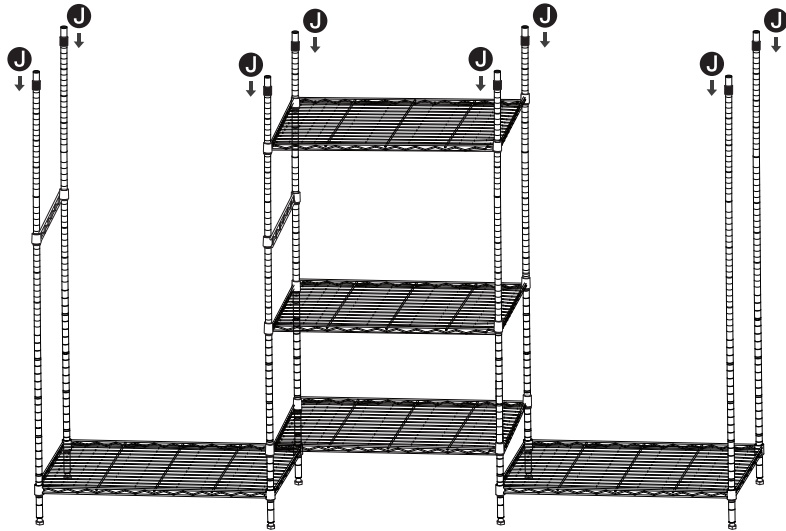

( 4 ) Install the Steel Shelves (part **A** ) onto the Clip groups.

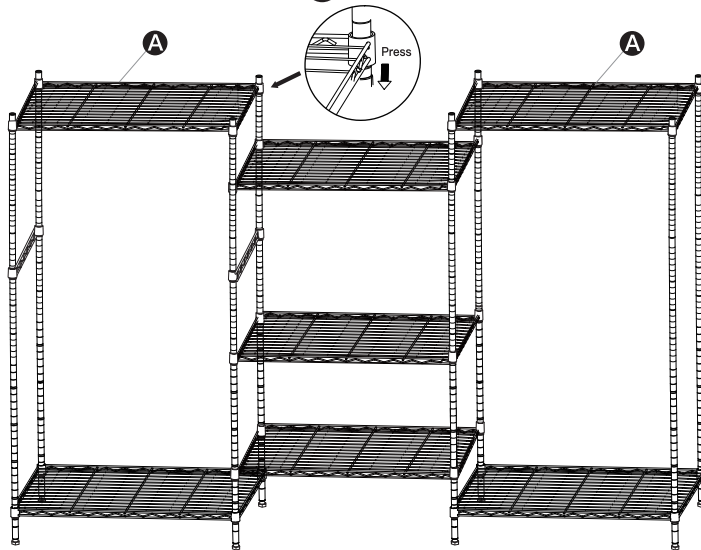

**Step 10**

Install part **G** on one side of part **F**, and tighten them with part **H**.

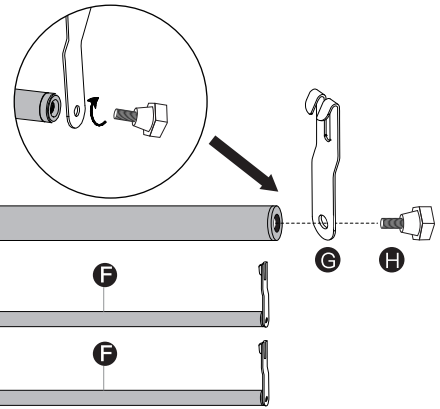

**Step 11** Install hanger on the rack.

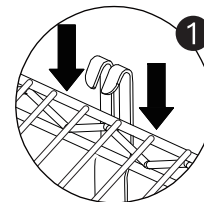
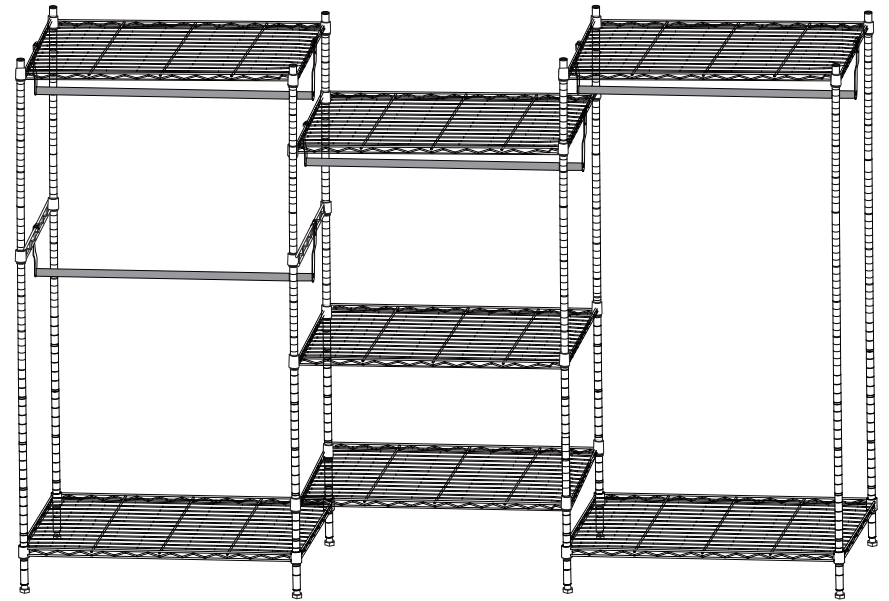

1. Put the assembled hook (Step 10) on the side of shelf.

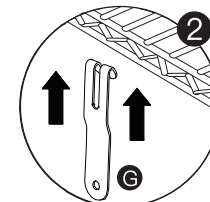

2. Put a single hook on the other side.

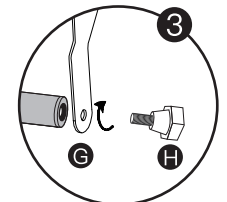

3. Screw part H into hook.

**REMARK:**

After each shelf is assembled, please put a piece of cloth on it and hit it several times with a tool(eg. A rubber mallet) to ensure more stability.

**Note:**

The rubber mallet is not included in the package.

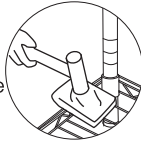

**Step 12** Install part **K** to keep the clothes rack more stable.

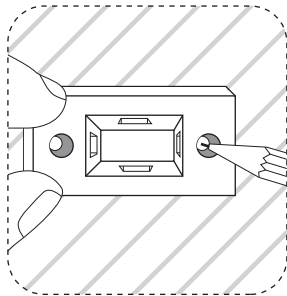

(1) Mark the location of bolt hole.

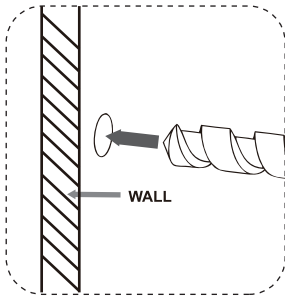

(2) Drill holes at marked location.

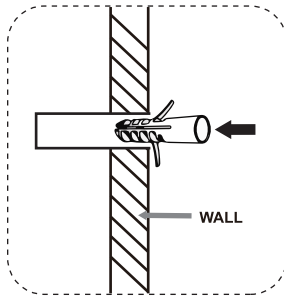

(3) Press the protective bolts in the wall.

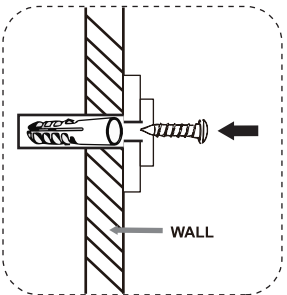

(4) Fix the safety lock on the wall with bolts.

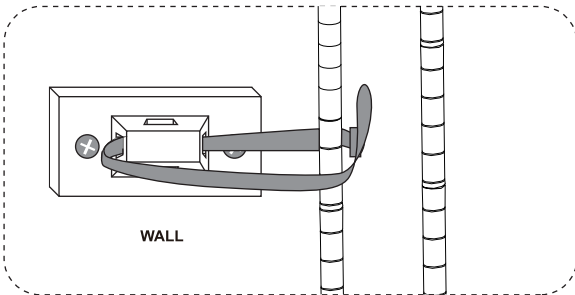

(5) Get the safety belts cross the lock and wire closet, then get fastened.

## ■ After-Sale Support

### Dear Customer,

Thank you so much for purchasing our product. We sincerely appreciate your choice to incorporate our product into your living space.

Our goal is to build a mutually beneficial relationships with customers and we aim to be a reliable and recommendable brand.

We sincerely hope this product meets your expectations and that you would consider us again for your future needs.

When you receive the package, please kindly double check your package and accessories to be sure that you have all the necessary parts.

Should you have any questions, please contact us through the original purchase platform.

We will reply to each message within 24 hours and spare no efforts to help you as always.

Thank you once again for choosing us. Here's to creating wonderful memories and comfortable spaces together!

Kindest Regards,  
Customer Care Team