

# DABBSSON

## Flexible Fixed Solar Panel

### User Manual

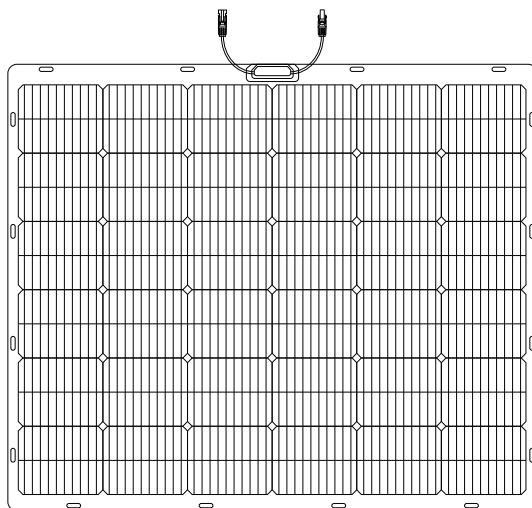

# DISCLAIMER



As the use of this manual as well as the conditions or methods for the installation, operation, use and maintenance of photovoltaic (PV) products may exceed the control We assumes no responsibility for such nonstandard installations and operations, and expressly disclaims any loss, damage, and maintenance requirements arising therefrom or in any way related thereto. We shall not be liable for any infringement of third-party patents or other rights that may result from the adoption of the installation methods, accessories, etc. that are not provided by our company during installation and use. The product information and installation examples in this manual are provided based on our and our partners' relevant knowledge and experience and are considered to be reliable; however, the restrictions and recommendations in such information, including product specifications, do not constitute any express or implied warranty. Before using the product, please read the User Manual and the disclaimer of liability for this product carefully. Once you use this product, it will be deemed that you have understood, acknowledged and accepted all the terms and contents of this document, and the user shall be responsible for their actions and all consequences arising therefrom. We hereby disclaims any liability for any losses due to the user's failure to use the product according to the User Manual. In compliance with laws and regulations, the company shall have the final right to interpret this document and all related documents for this product. Any update, revision or termination of the contents therefore, if necessary, shall be made without prior notice, and users may visit our official website for the latest information on the product.

# General Safety Information



1. Solar photovoltaic systems must only be installed by qualified personnel with relevant professional skills and knowledge.
2. All solar modules are equipped with a permanently connected junction box and 4mm<sup>2</sup> wires. Installers shall bear all risk of injury that may occur during installation, including, but not limited to, the risk of electric shock.
3. When exposed to direct sunlight, a single module may generate DC voltages greater than 24V. Exposure to DC voltages of 24V or higher is potentially dangerous. Arcing may occur when disconnecting wires that are connected to the PV components exposed to sunlight. Such arcing may cause burns or a fire. Please operate with special care, otherwise it may give rise to further issues. It is therefore important to protect yourself from electricity!
4. The solar modules convert solar energy into DC electricity, and they are designed for outdoor use. Modules can be mounted on top of a fixed outdoor object, and the system designer and installer shall be responsible for the compliance of the design of their supporting structure.
5. Do not attempt to disassemble the module, or remove any attached nameplates or components.
6. Do not apply paint, adhesives or substances that block the battery cell from light to the light-receiving surface of the module.
7. Do not expose the surface of the module to amplified sunlight that is artificially centralized.
8. When installing systems, please observe all local, regional and national laws and statutory regulations. When installing them on a vehicle or vessel, please observe relevant local and national laws and regulations.

# Safety Precautions



1. When light shines on the light-receiving surface of the solar module, the solar module will generate DC electricity with a voltage of over 24V. If modules are connected in series, the total voltage is equal to the sum of the voltage of each module. If modules are connected in parallel, the total current is equal to the sum of the current of each module.
2. When transporting and installing any mechanical and electrical components, please take care to keep children away from the system and installation site.
3. It is recommended that the light-receiving surface of the module be completely covered with opaque material during installation and that the positive and negative terminals be disconnected in order to prevent issues arising from power generation.
4. When installing or troubleshooting for a PV system, do not wear metal rings, straps, earrings, nose rings, lip rings or other metal devices, and only use insulated tools approved for electrical installation.
5. Please comply with safety instructions for all other components utilized in the system, including cables, connectors, controllers, charge regulators, inverters, batteries and other rechargeable batteries, etc.
6. Use only the relevant equipment, connectors, wiring and brackets applicable to the installation of this solar module system. Always use modules of the same type in a particular PV system. Bypass diodes have been integrated into the junction box for all modules.
7. For any single module or combination of more than one module connected in series or parallel, the cross-sectional area of the cable and the capacity of the connector must suit the maximum system short-circuit current, otherwise the cable and connector will overheat at high currents.
8. DC fuses must be appropriate for the module's over current protection rating.
9. Under normal outdoor conditions, the currents and voltages generated by the module will be different from those listed in the data sheet, depending on the weather and ambient temperature. Data specified on the nameplate are expected values under standard test conditions (STC).

# Installation Procedures and Precautions



Obtain information on any requirements and pre-approvals for the site, installation and inspection from the relevant authorities prior to installation.

When installing the product on the roof of a vehicle, ensure that the roof is protected against fire: The installation site should be free of flammable materials. The solar panel's positive and negative terminals should be fully disconnected before installation. Only use approved insulated tools for electrical installation.

## Pre-installation Requirements



Ensure that modules comply with general system technical requirements and that other system components will not damage the modules mechanically or electrically.

Modules can be connected in series to increase voltage or in parallel to increase current. In a series connection, the positive terminal of one module is transferred to the negative terminal of the second module. In a parallel connection, the positive terminals of one module and the second module are connected, so are their negative terminals.

## Certification



# Technical Parameters



## Electrical Data

**DBS200SF**

Model

**200W**

Max.Power(Pmax)

**24.5V**

Open Circuit Voltage(Voc)

**19.4V**

Voltage at Pmax (Vmp)

**10.3A**

Current at Pmax (Imp)

**11.1A**

Short Circuit Current(Isc)

**0~±5%**

Power Tolerance

**-0.35%/°C**

Temperature Coefficient(Pmax)

**+0.04%/°C**

Temperature Coefficient (Isc)

**-0.25%/°C**

Temperature Coefficient (Voc)

**Up to 23.4%**

Solar Cells Efficiency

\* STC(Standard Test Conditions): Irradiance 1000W/ m<sup>2</sup> , Cell Temperature 25°C, Air Mass AM1.5.

## Electrical Data, NMOT

**150W**

Nominal Max. Power(Pmax)

**22.89V**

Open Circuit Voltage (Voc)

**-41°C±3°C**

NMOT

**8.87A**

Short Circuit Current (Isc)

**18.10V**

Max. Power Voltage(Vmpp)

**8.26A**

Max. Power Current (Imp)

\* NMOT(Nominal Module Operating Temperature): Irradiance at 800w/ m<sup>2</sup> , Ambient Temperature 20°C, Wind Speed 1m/s.

## Mechanical Data

**4kg**

Weight

**IP68**

Solar panel

**4mm<sup>2</sup> ,500mm**

Cable

**MC4**

Connector

**72.8x182 Mono**

Solar Cell

**1150x970x14.5mm**

Dimensions

# Product Introduction



Front Side:

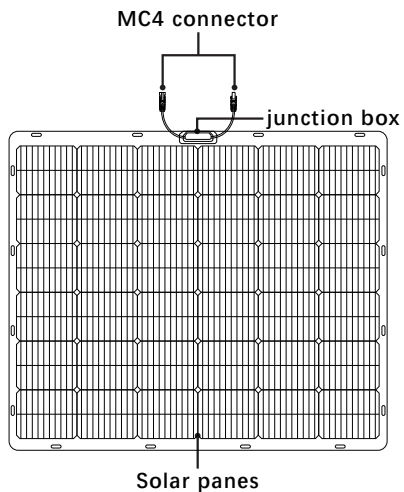

Back Side:

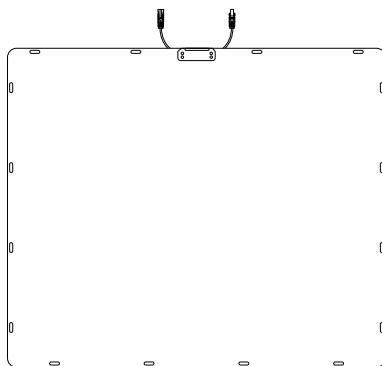

# Package Contents

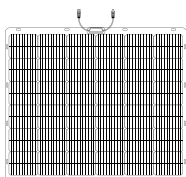

Flexible Fixed Solar Panel



Metal zip ties (X16)



User Manual

\* Products or accessories excluded in this package contents are sold separately.

It is recommended that modules with the same electrical output be connected in the same series to prevent mismatching from creating a  $1+1<2$  effect; Avoid shade, as even a small amount of shade will reduce power output; ensure that the sun will be able to shine on the module even on the shortest day of the year;

To generate the most electricity, the module should face directly south if it is in the Northern Hemisphere and face directly north if it is in the Southern Hemisphere. For details on the best elevation angle for the installation, refer to the standard PV installation guide of your locality or the installation angle requirements of a well-known solar installer or system integrator.

## Installation Precautions



All of the following installation methods are for reference only. We only supply some of the module installation and connection accessories (see packaging list for details), but it does not supply accessories for a complete system. Any system installers should ensure that the installation complies with all specifications.

The product panel is made of flexible material with 16 holes arranged at its edges, and can be fixed using optional adapter bolts through the spare holes or by using a structural adhesive or gluing double sided adhesive foam tape on the back of the panel.

Regardless of the installation method used, care should be taken to leave gaps between the panels and the roof to maintain airflow and ensure good heat dissipation for prolonged service life and power generation output.



# Balcony Microinverter Connection



## Installation Case 1

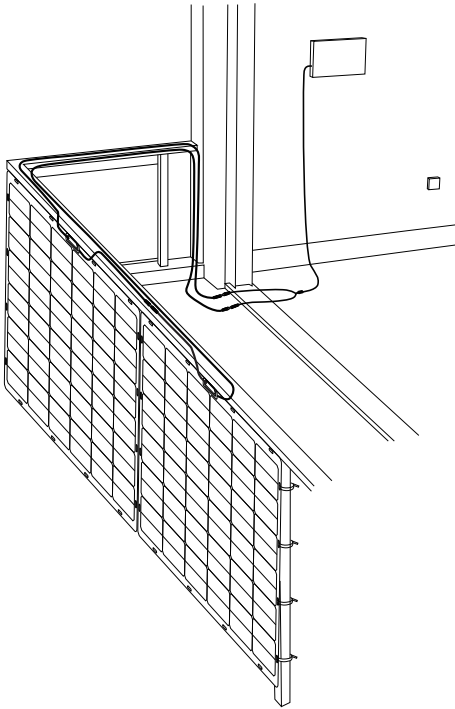

## Installation Case 2

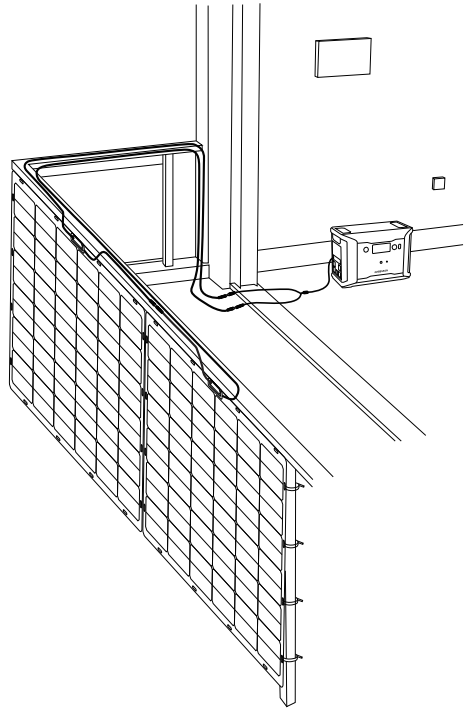

### Connection Method of Case 1

1. Use metal zip ties to fix the solar panels on the fence of the balcony.
2. Connect 2 solar panels in series with MC4 connector as 1 group. Total 2 groups of 4 solar panels.
3. Use the solar panel MC4 connectors's charging cable to connect with the solar panels' MC4 connectors respectively.
4. Plug the other end of solar panel charging cable to the balcony microinverter's interface.

## Connection Method of Case 2

There are two ways to connect the solar panels with the power station.

A. Series connection / B. Parallel connection

### A. Series connection

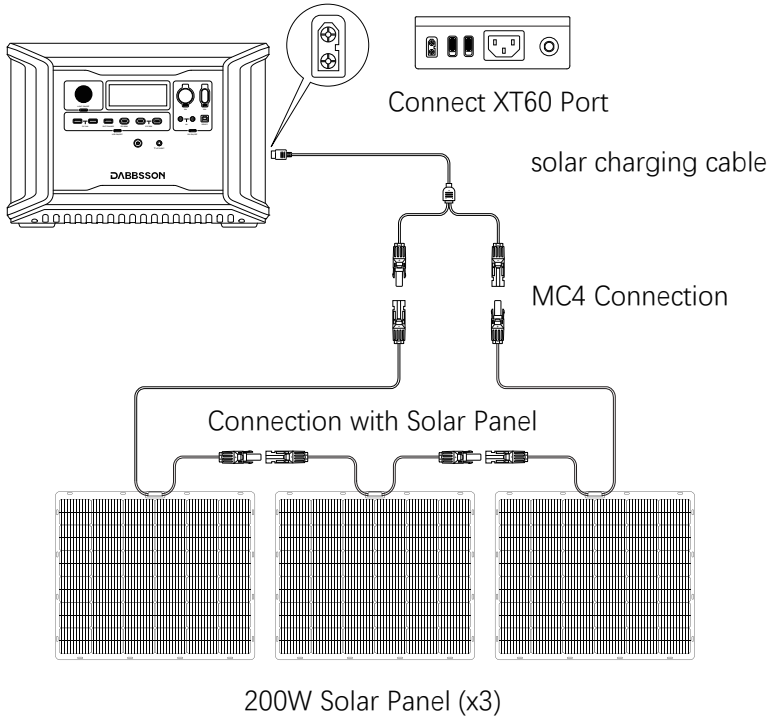

1. Connect solar charging cable with the portable power station's XT60 port;
2. Pull out the MC4 connectors on both solar panels;
3. Connect the positive terminal of one solar panel to the negative terminal of the other solar panel;
4. Connect the MC4 port of the device to the other terminal of each solar panel respectively.

## B. Parallel connection

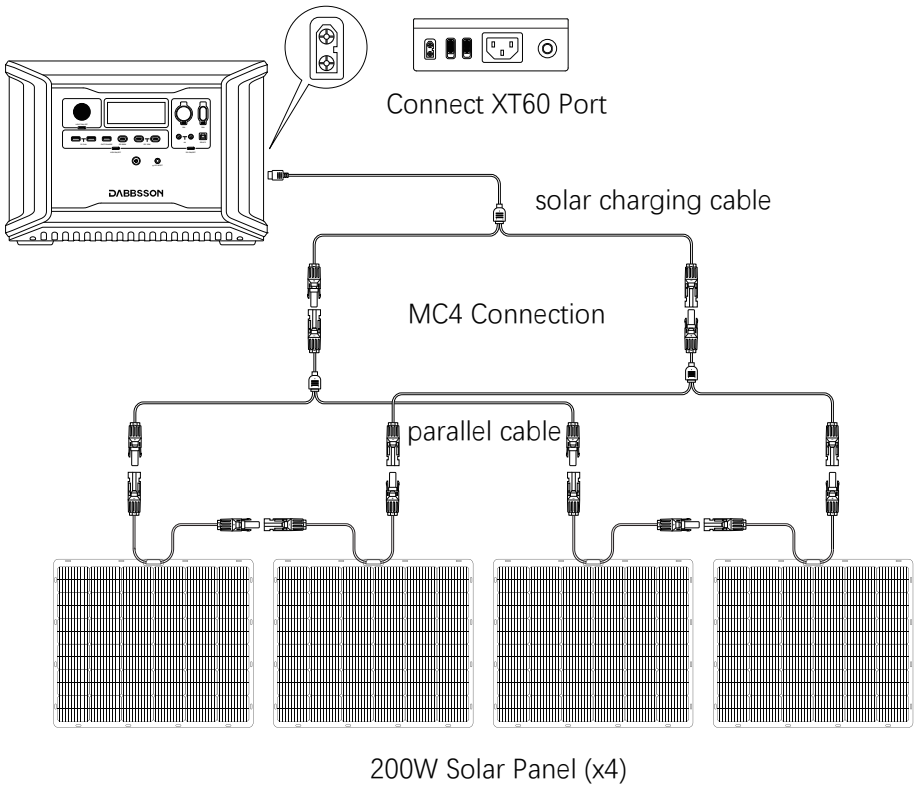

1. Connect solar charging cable with the portable power station's XT60 port;
2. Connect the parallel cable with the solar charging cable;
3. Two solar panels connected in series as one group, to connect the positive terminal of one solar panel to the negative terminal of the other solar panel.
4. Connect parallel cable with the two positive terminals and negative terminals of solar panels in parallel.

**Connection methods below are applicable to balconies, roofs, RVs, yachts and DABSSON portable energy storage products.**

\* Products or accessories excluded in this package contents are sold separately.

# Roof Solar System Connection



## Installation Case 1

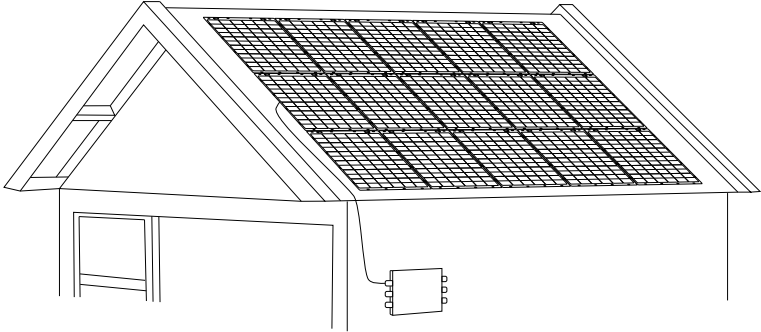

1. Use metal zip ties to fix the solar panels on the roof solar panel bracket.
2. Connect the solar panels in series or in parallel as the way mentioned above according to the parameters of the purchased photovoltaic inverter.
3. Plug the other end of solar panel charging cable to the photovoltaic inverter's interface.

## Installation Case 2

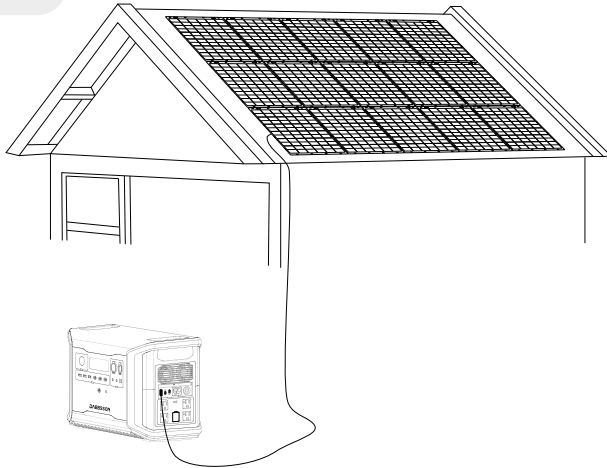

\* When use our device to connect the roof solar system, please refer to Balcony Micro inverter Connection Method of Case 2.

# RV Solar System Connection



## Installation Case 1

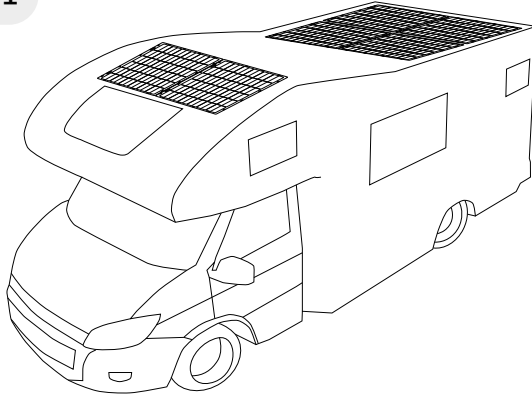

1. Use metal zip ties to fix the solar panels on the roof of RV.
2. Connect the solar panels in series or in parallel as the way mentioned above according to the parameters of the RV's micro inverter.
3. Plug the other end of solar panel charging cable to the RV's micro inverter.

## Installation Case 2

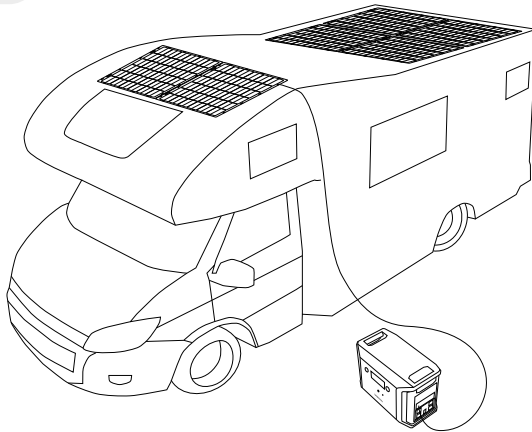

\* When use our device to connect the RV solar system, please refer to Balcony Micro inverter Connection Method of Case 2.

# Yacht Solar System Connection



## Installation Case 1

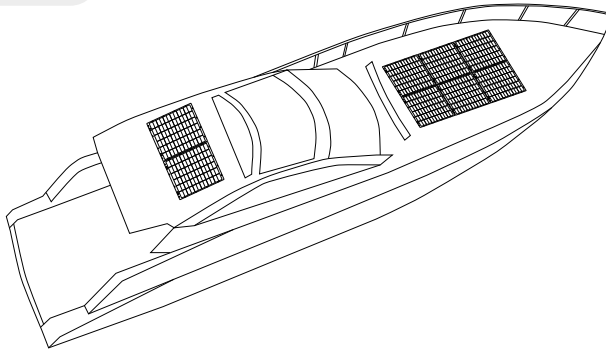

1. Use metal strips to fix the solar panels on the roof of Yacht.
2. Connect the solar panels in series or in parallel as the way mentioned above according to the parameters of the Yacht's micro inverter.
3. Plug the other end of solar panel charging cable to the Yacht's micro inverter.

## Installation Case 2

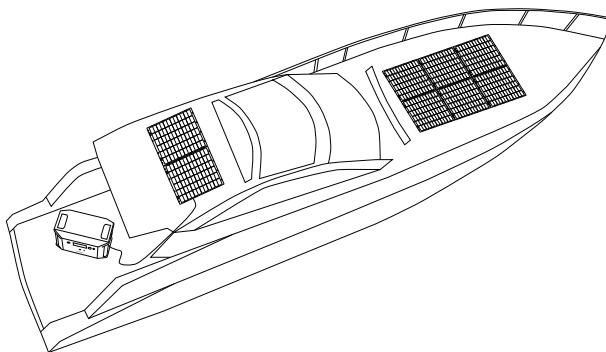

\* When use our device to connect the Yacht solar system, please refer to Balcony Micro inverter Connection Method of Case 2.

# Frequently Asked Question



## **Q1: Why does the Solar Panel fail to deliver as much as stated when in actual use?**

In most cases, it is normal for a solar panel not to deliver its full nominal power. Some of the reasons why this happens, as well as some suggestions for getting closer to the nominal power figure, are given below.

1. Light Intensity. The amount of light shining on the panel will result in fluctuations to the power output. You are more likely to achieve nominal power output figures closer to those obtained under test conditions when using the product on a clear day during the midday sun, than when using the product in the morning or later in the afternoon. Weather conditions will also affect the amount of sunlight that shines on the panel. For example, you are much less likely to achieve the figures for nominal power in hazy, cloudy or rainy conditions.

2. Surface Temperature. The temperature of the solar panel surface will also affect the amount of power generated. The lower the surface temperature of the panel, the more power will be produced. For example, solar panels generate more power when used during the winter than during the summer, and this is completely normal. Solar panels generally reach temperatures close to 60°C (140°F) during summer. This reduces nominal power by 10–15%, despite the higher levels of light shining on the panel.

3. The Angle of the Sunlight. Under good lighting conditions, the solar panel is able to stay where light hits perpendicular to the surface to achieve better light performance. However, most solar panels installed on the roof of an RV can only be installed in a tiled configuration, which prevents the panel(s) from being installed at the optimal angle, and this difference will result in a power output loss of approximately 5%-10%.

4. Panel Shading. The surface of the solar panel should not be shaded during use. Shading caused by shadows, foreign objects and glass can all greatly reduce power output.

Performance Issues caused by Malfunctioning Panels: If the panel still isn't generating power or its output remains far below expected nominal power figures after addressing the issues above, there may be an issue with the panel itself. Please contact Customer Support for assistance.

## **Q2: How much power can the Flexible Solar Panel generate under normal conditions?**

This depends first and foremost on weather conditions. Generally speaking, on a clear day with no clouds in the sky, sunlight hitting the panel at a 90° angle usually generates 70W–80W of power in the 100W panel (current light conditions are normally 800–900W/m<sup>2</sup> with a panel temperature of 50°C under test conditions. Nominal power ratings are based on 1.000W/m<sup>2</sup> in AM1.5 conditions with a panel temperature of 25°C under test conditions. Power output figures close to nominal values were normally observed in the midday sun during the winter).

### **Q3: What are the usage temperature range for use for the Panel?**

The operating temperature range of the solar panel is -20°C to 85°C.

### **Q4: Does the bend of the Panel have a large impact on The operating temperature range of the solar panel is -20°C to 85°C.power?**

The solar panel can be bent on certain surfaces, but the more the panel bends, the less efficient it is. This is because panel power generation is best only when the entire panel has a consistent light source. When bent, different areas of the flexible solar panel are exposed to different amounts of light, reducing power generation efficiency.

### **Q5: Can I use Solar Panels together in series?**

Yes. Please read the description of in series and parallel connections in the User Manual carefully, paying particular attention to energy storage controller requirements and limitations on solar panel output, so as not to cause solar panels with different currents to be used in series without releasing their power and creating a 1+1<2 effect. If use two solar panels in series , please pay attention to the voltage sum of two solar panels should be less than the devices' max. power voltage.

### **Q6: Can I connect Solar Panels in parallel?**

The maximum number of DBS200SF panels allowed in a parallel connection depends on the controller and energy storage equipment of your recreational vehicle. Please ensure that the energy storage system used in your vehicle supports a higher input current, and you should use wires with a diameter suitable to the output current to securely connect the panels in parallel.

### **Q7: Do I need to clean the Solar Panel regularly?**

Yes. There can be a lot of dust and foreign objects on the surface of the solar panel after the panel has been used outdoors for a long time, which block the light to a certain extent, reducing the power output. Regular cleaning can help keep the surface of the solar panel clean and free from obstructions and generate a higher power output. However, when cleaning, be careful to wipe the surface with soft materials such as cloth to prevent hard materials scratching the surface of the panel and affecting the output.



# Warranty



The product is covered by a limited warranty from Dabbsson for the original purchaser that covers the product from defects in workmanship and materials for 24 months from the date of purchase (damages from normal wear and tear, alteration, misuse, neglect, accident, service by anyone other than authorized service center, or act of God are not included).

During the warranty period and upon verification of defects, this product will be replaced when returned with proper proof of purchase.

# Declaration of Conformity



We, SHENZHEN DAIPUSEN NEW ENERGY TECHNOLOGY CO., LTD. declare under our sole responsibility that the above referenced product is in conformity with the applicable requirements of the following directives:

RED Directive:	2014/53/EU
RoHS Recast Directive:	2011/65/EU (EU)2015/863
REACH Regulation:	2006/1907/EC

Read the declaration of conformity and access the download link here at <https://dabbsson.com/pages/eu-compliance>

## Have any question? Chat with a specialist today.

	US: support.us@dabbsson.com
✉	EU: support.eu@dabbsson.com
	JP : support.jp@dabbsson.com

## Follow Us

- @Dabbsson\_Global
- @DabbssonOfficial
- @Dabbsson\_Official

