

Schlüter®-KERDI-BOARD

Substrate

waterproof substrate and structural board

12.1

Product data sheet

Application and Function

Schlüter®-KERDI-BOARD is a multifunctional tile substrate for wall areas, which can be used for creating bonded waterproofing assemblies with tile coverings. Additionally, the product has many uses as a structural panel.

It consists of an extruded hard foam panel, with a special reinforcement material on both sides and fleece webbing for effective anchoring in the tile adhesive.

With the available panel thicknesses of 5, 9, 12.5, 19, 28, 38 and 50 mm, Schlüter®-KERDI-BOARD covers a broad range of application areas for creating level, waterproof substrates for the installation of ceramic and natural stone tiles.

Schlüter®-KERDI-BOARD is waterproof and can withstand all chemical stresses that typically occur in conjunction with ceramic tile coverings. Where required, an approved bonded waterproofing assembly can be created with Schlüter®-KERDI-BOARD in specific areas.

Schlüter®-KERDI-BOARD is suitable for: creating tile substrates on green masonry, existing substrates of all kinds and stud frames made of wood or metal; creating straight or curved separating walls; concealing wall mounted installations and piping (pipe boxes); creating straight or curved bathtub and shower surrounds; as well as creating work surfaces, vanities, storage shelves or any other bathroom structures. The material is equally suitable for creating level substrates in floor renovation projects e.g. residential bathroom installations designed for foot traffic.

Schlüter®-KERDI-BOARD is simply cut to size with a utility knife. The gridlines printed on the surface are helpful for neat and quick installation.



Schlüter®-KERDI-BOARD can be fully adhered in wall areas or alternatively attached with dabs of adhesive. If necessary, the material may be secured with additional wall anchors. In the case of stud frames made of wood or metal, Schlüter®-KERDI-BOARD is attached with screws from the matching hardware system.

Tiles can be installed directly over Schlüter®-KERDI-BOARD using the thin-bed method, but other suitable trowel applied coverings or plaster layers can be utilised, please contact us for advice.

Schlüter®-KERDI-BOARD-N prefabricated installation elements are available for the creation of niches and storage surfaces in walls with a column structure.

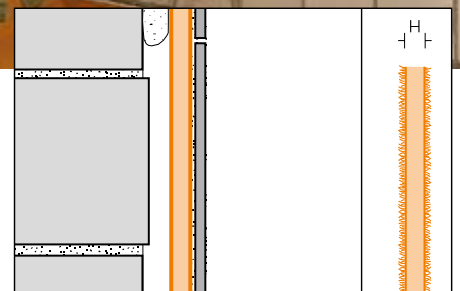



Schlüter®-KERDI-BOARD-E/-U and **-V** are prefabricated panels for creating, e.g. pipe coverings. They are available as angled, U-shaped and slotted Schlüter®-KERDI-BOARD panels for creating rounded edges. Schlüter-Systems also offers profiles and attachment hardware for wall connections and finishing edges, as well as matching wall anchors and screws.

Material

Schlüter®-KERDI-BOARD is made from an extruded XPS hard foam, with a cement-free reinforcement layer laminated onto both sides, together with an anchoring fleece webbing. The surface of the board has gridlines consisting of 10 x 10 mm squares printed on one side.



Material properties and areas of application

Schlüter®-KERDI-BOARD is waterproof and can withstand all chemical stresses that typically occur in conjunction with tile coverings. Schlüter®-KERDI-BOARD may be used in bonded waterproofing assemblies where required.

Schlüter®-KERDI-BOARD is completely level and remains free of distortions and decay. It will not rot and is highly stable, even with one side exposed to temperature fluctuations and moisture.

Schlüter®-KERDI-BOARD can be used for a multitude of different applications. In special cases, the suitability of the material must be verified based on the anticipated chemical and mechanical stresses. The information provided below is intended as general guidelines.

Substrates on which Schlüter®-KERDI-BOARD is to be installed need to be evaluated for their stability and other project specific requirements. Before directly adhering the panel with tile adhesive, remove all surface components that may weaken the bond. Otherwise, we recommend attaching the panel with additional fixings.

Select a suitable material thickness if using Schlüter®-KERDI-BOARD for the construction of non load bearing/free-standing partition walls, shelving or similar structures and use reinforcement profiles as necessary. The use of Schlüter®-KERDI-BOARD in floor assemblies is restricted to foot traffic areas, e.g. bathrooms, kitchens, etc.. Floor coverings may have a certain hollow sound

when they are walked upon with hard shoes or tapped with a hard object.

Select the material thickness and installation method depending on the evenness of the substrate. Thin panels of Schlüter®-KERDI-BOARD (5 mm) should be fully embedded in tile adhesive.

Areas of Application and Installation

Installation: Fully embedded Schlüter®-KERDI-BOARD

1. The adhesive must bond with the substrate and mechanically set in the anchoring fleece of Schlüter®-KERDI-BOARD. Standard dry set adhesives as defined by EN 12004 are suitable for most substrates; otherwise select another suitable adhesive, carefully checking for any incompatibilities of materials.
2. The thin-bed adhesive is applied either over the substrate or onto Schlüter®-KERDI-BOARD with a notched trowel.
3. The anchoring fleece of the Schlüter®-KERDI-BOARD panels are fully embedded in the adhesive bed. Observe the curing times of all materials.
4. Tightly abut the individual panels and align them appropriately.
5. The tiles can be installed immediately after adhering the Schlüter®-KERDI-BOARD panels, using a dry setting adhesive that meets the requirements of the covering. Choose a notched trowel to match the tile format. The curing times of the thin bed adhesive must be observed.

Note: See section "Waterproofing" on the use of Schlüter®-KERDI-BOARD in bonded waterproofing assemblies.

Attachment of Schlüter®-KERDI-BOARD with dabs of adhesive

1. Place dabs of adhesive on the Schlüter®-KERDI-BOARD panel at intervals of approx. 30 cm and ensure that all board edges are fully supported with adhesive.



Depending on the required thickness of the layer, use a suitable bonding adhesive.

- Set the panels at the wall, firmly press them in place and align them with the use of a spirit level.
- The tiles can be installed immediately after adhering the Schlüter®-KERDI-BOARD panel, using a thin-bed adhesive that meets the requirements of the covering. Choose a notched trowel to match the tile format. The curing times of the thin-bed adhesive must be observed.

Note: If no lasting adhesion can be created between the dabs of adhesive and the substrate, additional mechanical attachment with the corresponding wall anchors or screws is required.

Note: See section "Waterproofing" on the use of Schlüter®-KERDI-BOARD in bonded waterproofing assemblies.

Use of Schlüter®-KERDI-BOARD on stud frame structures

- Schlüter®-KERDI-BOARD can be installed and screw-mounted vertically or horizontally on professionally constructed stud frames. If using the system fixings, the panels may be tightly abutted when fixing the screws. The selected screws should be of sufficient length to reach a depth of at least 20 mm in wooden studs and at least 10 mm in metal studs. The distance between the screws should not exceed 25 cm. Depending on the project requirements, the panel thickness for installation on stud frame structures (centre line 62.5 cm) should be at least 19 mm.
- In the case of vertical installation, abut the individual panels over the centre of the studs. In the case of horizontal installation, seal all vertical joints that are not located over a stud with tile adhesive, Schlüter®-KERDI-FIX or the double sided adhesive tape Schlüter®-KERDI-BOARD-ZDK. Such abutting joints should be offset.

Note: See section "Waterproofing" on the use of Schlüter®-KERDI-BOARD in bonded waterproofing assemblies.

Use of Schlüter®-KERDI-BOARD in partition wall systems

- Schlüter®-KERDI-BOARD is adhered to the permanent wall with the abutting edge to make sure that the tile covering to be installed on the permanent wall includes the Schlüter®-KERDI-BOARD partition wall. If possible, the partition wall should be stabilised between Schlüter®-KERDI-BOARD panels adhered to the permanent wall. As an alternative, you can also screw-mount a matching angle or U shaped profile on the permanent wall for the attachment of the partition wall.
- Open ended partition walls can be further stabilised with the U shaped components of the attachment hardware. If you plan to screw fittings to the U-shaped profile, adhere the matching flat plastic profile Schlüter®-KERDI-BOARD-ZFP to the back of the U-shaped profile to improve the fixing of the screws. U shaped profiles may also be used for connections in the wall and ceiling area.
- All vertical and horizontal joints of Schlüter®-KERDI-BOARD panels must be sealed with thin-bed adhesive or Schlüter®-KERDI-FIX, if applicable. In the case of partition walls, a matching angle or U shaped profile may be included in one or several abutting joints for improved stability.
- Depending on the individual construction site requirements, such partition walls are considered lightweight walls without structural analysis. As a rule, use the 50 mm panels for this kind of structure. Panels from a thickness of 19 mm may be used for building shelving. Again, this must be evaluated in accordance with the building specifications.

Note: See section "Waterproofing" on the use of Schlüter®-KERDI-BOARD in bonded waterproofing assemblies.

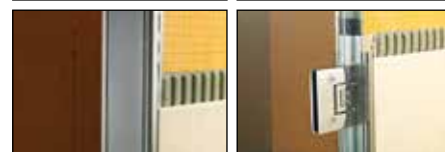

For accessories, see Page 7



Panel coverings made of Schlüter®-KERDI-BOARD

1. The angle and U shaped components of the Schlüter®-KERDI-BOARD attachment hardware allow for quick and easy panelling of piping and electrical installations.
2. The components with V-shaped grooves are supplied flat and can easily be cut to the required size. As an alternative, you can also cut a single U-shaped component into two angled elements with shorter legs.
3. The components are folded for installation, with a prepared adhesive strip holding them together in a V-shaped groove.
4. Adhere the edges of Schlüter®-KERDI-BOARD U-shaped or angled components to the existing walls, using either thin-bed adhesive or Schlüter®-KERDI-FIX. If required, mount the angle profile Schlüter®-KERDI-BOARD-ZW on the wall area first to attach the panel.

Note: See section “Waterproofing” on the use of Schlüter®-KERDI-BOARD in bonded waterproofing assemblies.

Curved wall areas made of Schlüter®-KERDI-BOARD

1. The grooved version of the Schlüter®-KERDI-BOARD panel is designed for creating rounded and curved structures.
2. First, cut the grooved panels to the required size. If a larger expanse of panels is required, several panels can be connected along the edges with double sided adhesive tape.
3. If the grooved surface points toward the inside, it is recommended to fill the grooves with tile adhesive prior to installation.
4. Exterior grooves should be filled with thin-bed adhesive prior to or during the tile installation.

Note: See section “Waterproofing” on the use of Schlüter®-KERDI-BOARD in bonded waterproofing assemblies.

Use of Schlüter®-KERDI-BOARD in floor areas

1. Schlüter®-KERDI-BOARD is equally suitable for creating level substrates in floor renovation projects, for example in bathroom installations.
To install Schlüter®-KERDI-BOARD in 5, 9, 12.5 and 19 mm thicknesses the

substrate must be level, ready to bear weight and free of all substances that may weaken the bond. Any levelling must be completed prior to installing Schlüter®-KERDI-BOARD.

2. The adhesive must bond well with the substrate and mechanically set in the anchoring fleece of Schlüter®-KERDI-BOARD. Standard dry set adhesive as defined by EN 12004 are suitable for most substrates. Otherwise, select another suitable adhesive, carefully checking for any incompatibilities of materials.
3. Apply thin-bed adhesive over the substrate with a notched trowel and fully embed the anchoring fleece of the Schlüter®-KERDI-BOARD panels in the adhesive bed. Tightly abut the individual panels and align them appropriately. Observe the curing times of all materials.
4. Provided the substrate is sufficiently load-bearing, Schlüter®-KERDI-BOARD panels from a thickness of 28 mm can be installed with spots of thin-bed adhesive or other suitable adhesive, followed by height alignment. To ensure proper weight bearing of the covering, place the dabs of adhesive closely together. Apply thin-bed adhesive to the joints at the edges of the panels and ensure they are supported by dabs of adhesive from below.
5. Use an edge strip to eliminate the build-up of tensions in Schlüter®-KERDI-BOARD and the tile covering in edge areas.
6. The tiles (minimum size: 5 x 5 cm) can be installed immediately after fully embedding the Schlüter®-KERDI-BOARD panels, using a dry setting adhesive that meets the requirements of the covering. If using dabs of adhesive, allow them to cure first for full weight bearing of the substrate. Choose a notched trowel to match the tile format. The curing times of the thin-bed adhesive must be observed.
7. Observe the applicable technical standards for movement joints used in field definition and edge and connection joints.

Note: See section “Waterproofing” on the use of Schlüter®-KERDI-BOARD in bonded waterproofing assemblies.





Schlüter®-KERDI-BOARD-N

Schlüter®-KERDI-BOARD-N are prefabricated niches for the easy installation of visually appealing shelves that are flush with the wall.

The niche is installed between two studs in a stud wall structure. An additional substructure must be set up to support the niche flange in case of larger stud intervals. If the niche is installed in high-moisture areas, tiles on the shelf surfaces must be installed with a slope to prevent water from pooling in the final assembly.

Installation in KERDI-BOARD:

1. Position the niche after precisely marking its outside dimensions and make a corresponding cut in the wall panelling.
2. Attach the inserted niche with wood screws or quick installation screws, depending on the material of the substructure. The maximum distance between screws is 250 mm. If using wall panels made of Schlüter®-KERDI-BOARD, insert the washers Schlüter®-KERDI-BOARD-ZT. In this case, place the screws in the joints near the abutting seams. For additional attachment, apply the installation adhesive Schlüter®-KERDI-FIX on the inside of the niche flange.
3. If the structure is installed in a high-moisture area, the abutting seams around the outer flange must be covered with the supplied KERDI waterproofing collar, using the sealing adhesive Schlüter®-KERDI-COLL-L.

Note: See section “Waterproofing” on the use of Schlüter®-KERDI-BOARD in bonded waterproofing assemblies!

Installation in drywall:

1. Position the niche after precisely marking its outside dimensions and make a corresponding cut in the wall panelling.
2. Attach the inserted niche with wood screws or quick installation screws, depending on the material of the substructure. The maximum distance between screws is 250 mm. If panelling materials such as drywall panels are used, screws must be inserted through the niche flange (distance of approx. 6 mm from the outer edge).

For additional attachment, apply the installation adhesive Schlüter®-KERDI-FIX on the inside of the niche flange.

3. Wall surfaces made from materials such as drywall that are located in a high-moisture area must be waterproofed with Schlüter®-KERDI. Adhere the supplied KERDI waterproofing collar on the niche flanges with the sealing adhesive Schlüter®-KERDI-COLL-L. A dry-set adhesive can be used for the remainder of the wall area (see product data sheet 8.1 for installation of Schlüter®-KERDI). Then cut out the KERDI membrane in the area of the niche cavity.

Important:

The following installation notes must be observed for using the niches with additional shelves:

As a first step, mark the desired position along the bottom of the shelf. Completely embed the tiles on the frontal and lateral areas of the niche in thin-set adhesive, working from the top down. When installing the shelf, apply adhesive on the sides and the back of the shelf and insert it into the niche in such a way that it is supported by the previously installed tiles.

Note: If the shelf is installed in a high-moisture area, elevate it slightly at the rear to create a slope. As an alternative, the tiles can also be installed with a slope offset in the adhesive to prevent water from pooling in the final assembly.



Installation in drywall

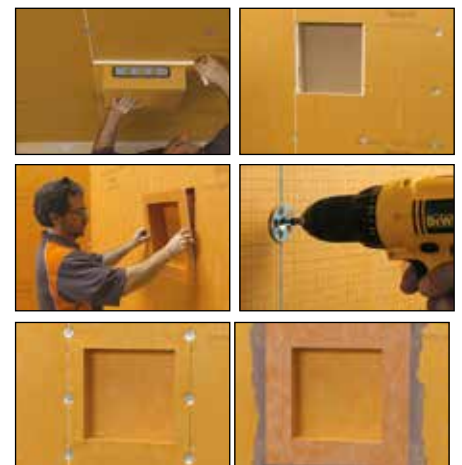

Installation in KERDI-BOARD





Waterproofing with Schlüter®-KERDI-BOARD

Schlüter®-KERDI-BOARD can be used in accordance with the German waterproofing standard DIN 18534. Water exposure classes: W0-I to W3-I*. Furthermore, Schlüter®-KERDI-BOARD features the national technical approval (abP) required in Germany.

Moisture load class according to ZDB: 0 to B0 and A and C.

Schlüter®-KERDI-BOARD features European Technical Approval (ETA) pursuant to ETAG 022 (watertight covering kits) and bears a CE mark. It must be ensured that only system-approved thin-set mortars are used in areas that require CE conformity or compliance with the general certificate of national technical approval. Please contact the address specified in this data sheet for further information on suitable thin-set mortars and the corresponding test certificates.

** With abP and/or in compliance with ETA according to ETAG 022. Please contact our Application Technology department for further information regarding use and installation.*

If constructing designs of load category B, "Containers" (e.g. swimming pools), we recommend the use of our waterproofing membrane Schlüter®-KERDI (see product data sheet 8.1 Schlüter®-KERDI).

For this purpose, the seams and corners of Schlüter®-KERDI-BOARD in the area must be fully covered with the seaming tape Schlüter®-KERDI-KEBA (minimum width 12.5 cm), embedding the sealing adhesive Schlüter®-KERDI-COLL-L. The seaming tapes should have at least 5 cm of overlap. Schlüter®-KERDI-KEBA band is also suitable for creating functional connections to fixed structural elements such as door openings or windows of metal, wood or plastic. For this purpose, apply Schlüter®-KERDI-FIX on the adhesive area of the fixed structures and Schlüter®-KERDI-COLL-L on the adhesive area of Schlüter®-KERDI-BOARD and cover the entire joint area with sealing band. The suitability of Schlüter®-KERDI-FIX for the built-in components must be verified in each individual case. The feasibility of the connections must be evaluated on the basis of individual construction requirements. Implement all connections with great care. Separate Schlüter®-KERDI-BOARD above the existing movement joints and structural joints and cover the abutting joints with Schlüter®-KERDI-FLEX. Schlüter®-KERDI-FLEX is also recommended for flexible edges.



Plaster and trowel-applied coatings over Schlüter®-KERDI-BOARD

These materials may adjoin tiled coverings (e.g., tiled skirtings) or be applied to entire walls in other areas. Abutting joints within the area, at the internal and external corners, and at exposed edges must be reinforced and covered with a trowel-applied material. The self-adhesive joint reinforcement tape Schlüter®-KERDI-BOARD-ZSA should be used for this purpose.



Schlüter®-KERDI-BOARD-ZSA



Product Overview



Schlüter®-KERDI-BOARD

used as a substrate and a universal structural panel, as well as in bonded waterproofing assemblies.

Width = 62.5 cm H = Height/thickness

Length	1.25 m	2.60 m
H = 5 mm	•	•
H = 9 mm	•	•
H = 12.5 mm	•	•
H = 19 mm	•	•
H = 28 mm	•	•
H = 38 mm	•	•
H = 50 mm	•	•

Schlüter®-KERDI-BOARD-N

prefabricated niches/shelves made of 12.5 mm Schlüter®-KERDI-BOARD for installation in walls.

Internal opening width = 305 mm

Internal opening depth = 89 mm

Internal height	Shelf
H = 152 mm	
H = 305 mm	
H = 508 mm	•
H = 711 mm	•



Schlüter®-KERDI-BOARD-E

angled component used to create corner formations and pipe panelling.

Width = 62.5 cm H = Height/thickness

Length	2.60 m
H = 12.5 mm	•
H = 19 mm	•
H = 28 mm	•

Segmentation: 31.25 x 31.25 cm

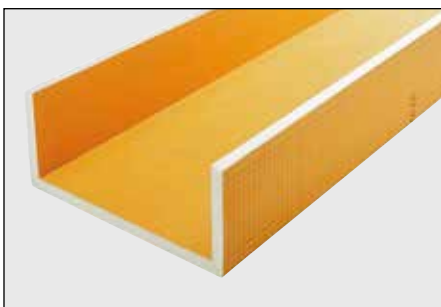

Schlüter®-KERDI-BOARD-U

a U shaped component to create pipe panelling.

Width = 62.5 cm H = Height/thickness

Length	2.60 m
H = 19 mm	•

Segmentation: 21.25 x 20 x 21.25 cm,
16.25 x 30 x 16.25 cm

Note: U shaped components may be divided into two angle components.

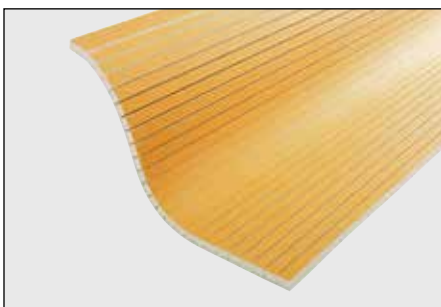
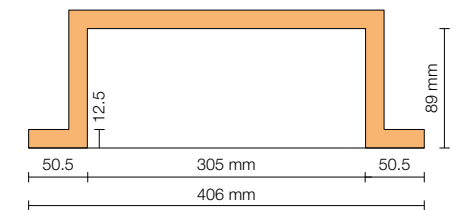

Schlüter®-KERDI-BOARD-V

a vertically grooved substrate and construction panel for creating tile coverings with curved installation substrates.

Width = 62.5 cm H = Height/thickness

Length	2.60 m
H = 9 mm	•
H = 12.5 mm	•
H = 19 mm	•
H = 28 mm	•
H = 38 mm	•
H = 50 mm	•

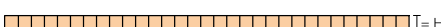



Schlüter®-KERDI-BOARD-ZW

Schlüter®-KERDI-BOARD-ZW is a 30 x 30 x 0.6 mm stainless steel angled profile with two trapezoid perforated anchoring legs. It is used for fastening and stabilising structures made of Schlüter®-KERDI-BOARD panels. It is either attached with screws or thin-bed adhesive.

Length	0.15 m	2.50 m
30 x 30 mm	•	•

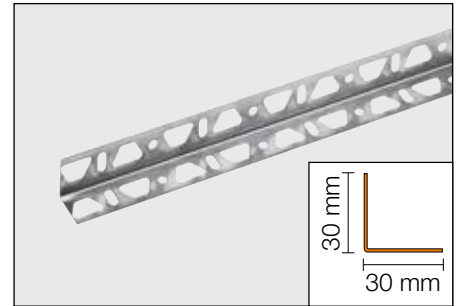

Schlüter®-KERDI-BOARD-ZC / -ZA / -ZB

Schlüter®-KERDI-BOARD-ZC is a U-shaped profile of brushed stainless steel with one perforated anchoring leg. It is particularly suited for finishing the edges of work surfaces, vanities and similar structures.

Length supplied: 2.50 m

Accessories	Profile	Corner	Connector
H = 19 mm	–	–	•
H = 28 mm	–	–	•
H = 38 mm	•	•	•
H = 50 mm	•	•	•



Schlüter®-KERDI-BOARD-ZA is a U-shaped profile of brushed stainless steel with two perforated anchoring legs. It is suited for visible edges of partition walls and shelves.

Length supplied: 2.50 m

Accessories	Profile	Corner	Connector
H = 19 mm	•	–	•
H = 28 mm	•	–	•
H = 38 mm	•	•	•
H = 50 mm	•	•	•

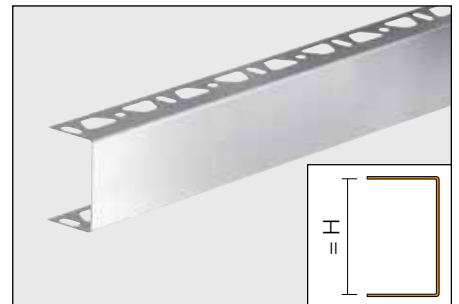

Schlüter®-KERDI-BOARD-ZB is a U-shaped profile of stainless steel with three sided perforation. It is used for fastening and stabilising structures made of Schlüter®-KERDI-BOARD panels.

Length supplied: 2.50 m

Accessories	Profile	Corner	Connector
H = 19 mm	•	–	–
H = 28 mm	•	–	–
H = 38 mm	•	–	–
H = 50 mm	•	–	–

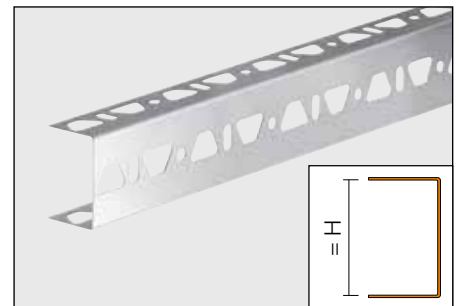

Schlüter®-KERDI-BOARD-ZSD

Schlüter®-KERDI-BOARD-ZSD are anchors made of galvanised steel or stainless steel for the additional mechanical attachment of Schlüter®-KERDI-BOARD to the substrate.

Material	Galvanised	Stainless steel
L = 90 mm	•	•
L = 110 mm	•	•





Schlüter®-KERDI-BOARD-ZT

Schlüter®-KERDI-BOARD-ZT are fixing washers made of galvanised steel or stainless steel for the attachment of Schlüter®-KERDI-BOARD to stud frame structures with the corresponding screws.

Material	Galvanised	Stainless steel
Ø 36 mm	•	•

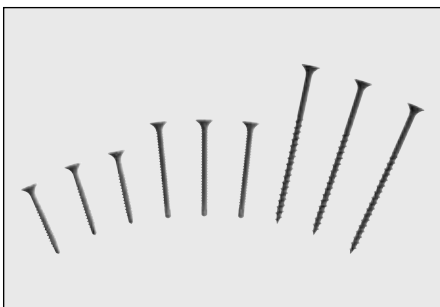

Schlüter®-KERDI-BOARD-ZS

Schlüter®-KERDI-BOARD-ZS are quick installation screws for the attachment of Schlüter®-KERDI-BOARD to stud frame structures.

3.5 x 35 mm with self tapping tip (for wood and metal thicknesses up to 2.25 mm)
3.5 x 55 mm with self tapping tip (for wood and metal thicknesses up to 2.25 mm)
4.2 x 75 mm with coarse threading (for wooden structures)



Schlüter®-KERDI-BOARD-ZDK

Schlüter®-KERDI-BOARD-ZDK is a double sided adhesive tape for the attachment of Schlüter®-KERDI-BOARD panels in joint areas or similar.

Length	10 m
B = 12 mm	•
B = 19 mm	•
B = 30 mm	•



Schlüter®-KERDI-BOARD-ZFP

Schlüter®-KERDI-BOARD-ZFP is a flat plastic profile, which is adhered behind the U-shaped profile giving strong reinforcement for fixing screws.



Schlüter®-KERDI-BOARD-ZSA

Schlüter®-KERDI-BOARD ZSA is a self-adhesive joint reinforcement tape for joints for use with trowel applied covering materials or plaster.

Length	45 m
B = 100 mm	•

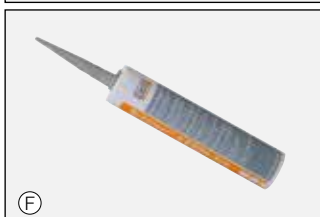

System products for bonded waterproofing assemblies

Schlüter®-KERDI-KEBA (Band) ^(A)
Thickness = 0.1 mm

Length	5 m	30 m
Width = 8.5 cm	•	•
Width = 12.5 cm	•	•
Width = 15 cm	•	•
Width = 18.5 cm	•	•
Width = 25 cm	•	•

see product data sheet 8.1

Schlüter®-KERDI-FLEX ^(B)
Thickness = 0.3 mm

Length	5 m	30 m
Width = 12.5 cm	•	•
Width = 25 cm	•	•

Schlüter®-KERDI-KM (Pipe collar) ^(C)
Thickness = 0.1 mm

Cutout Ø 15 cm / Hole Ø 22 mm	
KM 5117 / 22	Set = 5 pieces

Schlüter®-KERDI-KERECK ^(D)
Thickness = 0.1 mm

Internal Corner	2 Pc.	5 Pc.	10 Pc.
prefabricated	•	•	•
pre cut section		•	
External Corner	2 Pc.	5 Pc.	10 Pc.
prefabricated	•	•	•
pre cut section		•	

Schlüter®-KERDI-COLL-L ^(E)

Sealant adhesive	4.25 kg
	1.85 kg

see product data sheet 8.4

Schlüter®-KERDI-FIX (Installation adhesive) ^(F)
G = grey, BW = brilliant white

Colour	G	BW
Cartridge 290 ml	•	•

see product data sheet 8.3

Schlüter®-KERDI-DRAIN (Floor drains) ^(G)

see product data sheet 8.2

Schlüter®-KERDI-LINE (Linear floor drains) ^(H)

see product data sheet 8.7

Schlüter®-KERDI-SHOWER (Tray) ^(I)

see product data sheet 8.8

Schlüter®-KERDI-TS (set for waterproofing connection/ bathtubs and showers) ^(J)

see product data sheet 8.9





Technical data:

Thermal conductivity	DIN EN 12667	0.035 W/mK
Temperature resistance		-50 to +75°C
Material density (hard foam)	DIN EN 1602	33 kg/m ³
Water penetration capacity		0
Water vapour diffusion resistance rating*	DIN EN 12086	
Panel thicknesses 5, 9, 12.5 mm		$\mu = 1550$
Panel thicknesses 19, 28, 38, 50 mm		$\mu = 440$
Linear heat expansion coefficient		0.007 mm/mK
Useable area		
Panel size 125 x 62.5 cm		0.78 m ²
Panel size 260 x 62.5 cm		1.62 m ²

*s_v value = Panel thickness [m] · μ

Notes

Schlüter®-KERDI-BOARD should be stored flat or in another suitable manner. In case of outdoor storage, protect the material from direct sunlight or weather influences. If installing bathroom fittings such as vanities, toilets or other heavy objects, the material must be anchored in the weight-bearing substrate. In the case of stud frame substrates or wall mounted installation, the material must be attached to weight-bearing components with abutments in the lower area of the structures, which may need to be reinforced.



Text template for tenders:

_____m² Schlüter®-KERDI-BOARD as a substrate for tiles made of extruded hard foam, with special cement-free reinforcement material and an integrated anchoring fleece laminated on both sides to bond with the tile adhesive, to be supplied and professionally installed; while observing the manufacturer's instructions,

- On wall areas, consisting of _____ with suitable material (adhesive)
 - Fully embedded
 - Adhesive dab attachment
 - With additional mechanical anchoring, using
 - Stainless steel anchors
 - Galvanised anchors.
- On stud frame structures made of
 - Metal
 - Wood
- Screw mounted on wall mounted installation systems including the required connections.

The wall areas are to be completed:

- Without waterproofing function.
- For bonded waterproofing.

The applicable material requirements must be observed.

Material: _____ .../m²
 Labour: _____ .../m²
 Total price: _____ .../m²

Text template for tenders:

_____linear metres

- Schlüter®-KERDI-BOARD-ZA
- Schlüter®-KERDI-BOARD-ZB
- Schlüter®-KERDI-BOARD-ZC

as a stainless steel U-shaped profile with a trapezoid perforated anchoring leg, with dimensions to match the panel thickness for use as _____,

to be supplied and professionally installed while observing the manufacturer's instructions.

Material: _____ .../m
 Labour: _____ .../m
 Total price: _____ .../m

Text template for tenders:

_____m² Schlüter®-KERDI-BOARD as self supporting partition wall system and tile substrate made of extruded hard foam, with special cement-free reinforcement material and an integrated anchoring fleece laminated on both sides to bond with the tile adhesive, to be supplied and professionally installed; including all required materials and observing all manufacturer instructions, in the following rooms:

_____,
 using panel thicknesses of _____ mm, including the required connections.

The wall areas are to be completed

- Without waterproofing function.
- For bonded waterproofing.

The applicable material requirements must be observed.

Material: _____ .../m²
 Labour: _____ .../m²
 Total price: _____ .../m²

Text template for tenders:

As an accessory to the above item _____ linear metres Schlüter®-KERDI-BOARD-ZW as a stainless steel angle profile with dimensions 30 x 30 x 0.6 mm with two trapezoid perforated anchoring legs for use as _____,

to be supplied and professionally installed while observing the manufacturer's instructions.

Material: _____ .../m
 Labour: _____ .../m
 Total price: _____ .../m

Text template for tenders:

_____m² Schlüter®-KERDI-BOARD as a tile substrate in floor areas made of extruded hard foam, with special cement-free reinforcement material and an integrated anchoring fleece laminated on both sides to bond with the tile adhesive, to be supplied and professionally installed, including all required materials and observing all manufacturer instructions, onto a floor substrate consisting of _____ in rooms to be used as _____ (foot traffic only), including the required connections.

The floor areas are to be completed

- Without waterproofing function.
- For bonded waterproofing.

The applicable material requirements must be observed.

Material: _____ .../m²
 Labour: _____ .../m²
 Total price: _____ .../m²

Text template for tenders:

Supply _____ pieces Schlüter®-KERDI-BOARD-N as a prefabricated niche (shelf) made of Schlüter®-KERDI-BOARD as a tile installation substrate

- H = 152 mm
- H = 305 mm
- H = 508 mm
- H = 711 mm

to be supplied and professionally installed while observing the manufacturer's instructions.

Art.-No.: _____
 Material: _____ .../m
 Labour: _____ .../m
 Total price: _____ .../m