

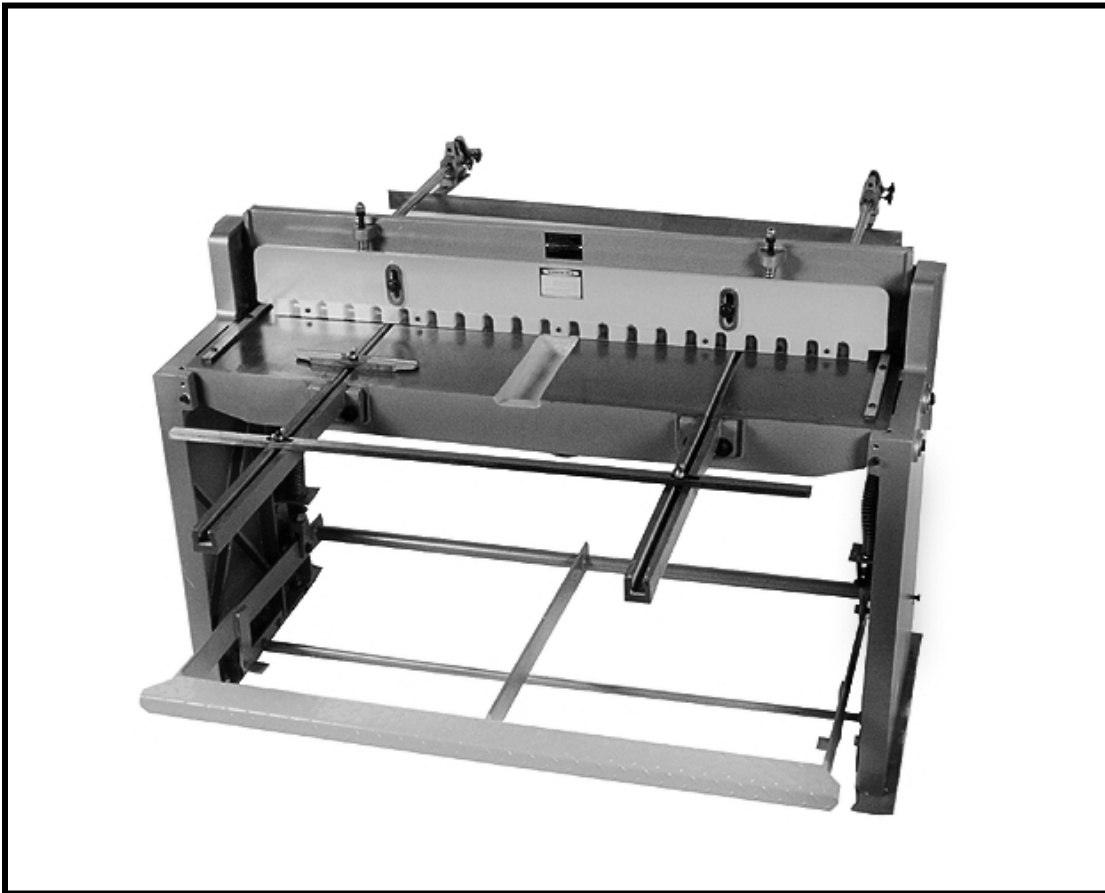

# MODEL CX817 52" FOOT SHEAR USER MANUAL



# TABLE OF CONTENTS

CX817 Safety Instructions.....	3
CX817 Features .....	4
CX817 Physical Features.....	5
Unpacking .....	6
Mounting .....	6
Foot Pedal.....	6
Front Extension Arms.....	7
Rear Extension Arms .....	7
Hold Down Adjustments.....	7
Blade Adjustment.....	8
Adjusting Blade Bow .....	8
Finger Guard .....	9
Stops & Guides .....	9
Blade Care .....	9
Return Spring Tension .....	9
Lubrication.....	9
Parts Diagram .....	10
Parts List .....	11
Warranty.....	12

## CX817 SAFETY INSTRUCTIONS

- Do not exceed the capacities of the machines. Overloading it, can cause damage to the machine and the work-piece.
- Only use this machine for the purpose it is designed. Do not modify for a purpose not intended by the manufacturer.
- Always keep your hands away from the pinching points of machine.
- Always wear gloves, safety glasses and safety shoes when operating this machine.
- Always check your machine for any damaged punch, loose bolts or nuts and any other unsafe condition before operation.
- Always have a secure footing when using this machine.
- Always keep the knives/cutters properly adjusted and sharp.
- Always keep children away from the work area.
- Make sure all guards are in place and in working order before operation.
- Do not use and store this machine in rainy or wet locations. Always keep your work area clean and dry.
- Always read and understand the instructions given in this manual before operating your machine. Failure to do so could result in serious personal injury and damage to the machine.

### **WARNING!**

*The safety instructions given in this manual can not be complete because the environment in every shop is different. Always consider your safety first as it applies to your individual working conditions.*



# 52" FOOT SHEAR FEATURES

## MODEL CX817 - 52" FOOT SHEAR

As part of the growing line of Craftex CX-Series machineries, we are proud to offer the CX817 a 52" Foot Shear. By following the instructions and procedures laid out in this user manual, you will receive years of excellent service and satisfaction. The CX817 is a professional tool and like all power tools, proper care and safety procedures should be adhered to.

### **CAPACITY**

- ✦ Shear ..... 52" @ 16 Gauge Mild Steel
- ✦ Front Gauge Range ..... 0 - 12-1/2"
- ✦ Back Gauge Range ..... 0 - 35"
- ✦ Maximum Depth ..... 37"

### **CONSTRUCTION**

- ✦ Shear Blades ..... Precision Ground Hardened Steel
- ✦ Frame ..... Cast Iron
- ✦ Table ..... Cast Iron Machined
- ✦ Hold Down Clamp ..... Cast Iron

### **DIMENSIONS**

- ✦ Height ..... 41"
- ✦ Foot Print ..... 60" x 22"

# CX817 PHYSICAL FEATURES

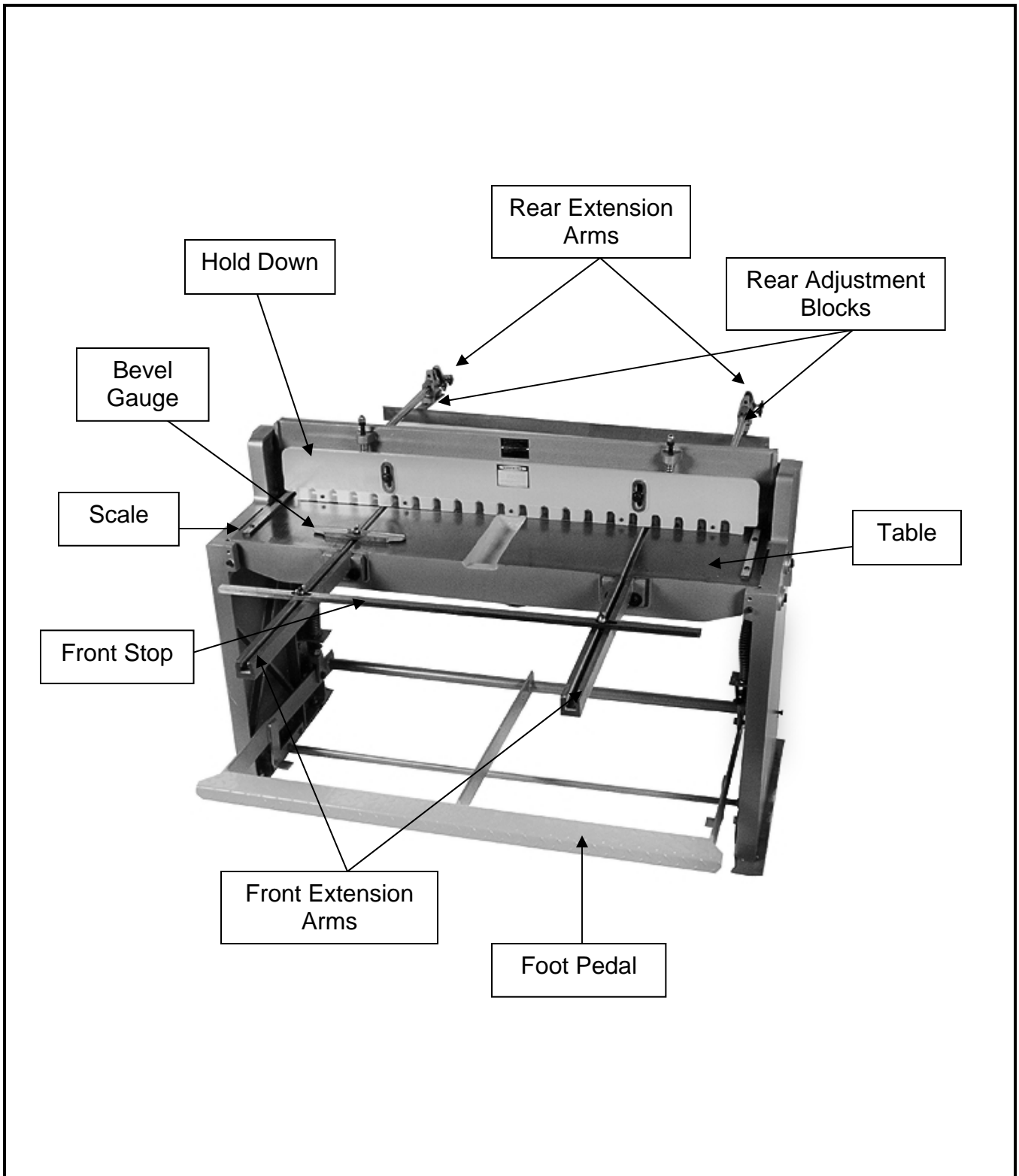

## UNPACKING

The CX817 is properly packaged in a carton for safe transportation. When unpacking, carefully inspect the carton and ensure that nothing has been damaged during transit.

While doing the inventory if you can not find any parts, check if the part is already installed on the machine.

### **WARNING!**

*The CX817 is a very heavy machine. Do not overexert yourself. Use a forklift or other mechanical device to lift and move the shear.*

## MOUNTING

The CX817 features four pre-drilled holes on its base which allow mounting it to the shop floor. It is recommended to mount the shear to the shop floor for safety and to offer the best overall performance. Mounting hardware is not included with the machine.

Lag shield anchors with lag bolts and anchors studs are two popular methods for mounting the machine to the concrete floor. Anchor studs are stronger and more permanent alternatives to the lag shield anchors.

## FOOT PEDAL

To assemble the foot pedal you will need the help of an assistant.

### TO INSTALL THE FOOT PEDAL:

Loosen the set screws holding the hinge pins in place and slide them outward.

Lift the foot pedal with the help of an assistant and position it over the hinge pin hole and insert the hinge pin.

Secure it by tightening the set screws.

Link the two swivel bottoms through the side arms of the foot pedal with the supplied bolts and tighten in position. See figure-1.

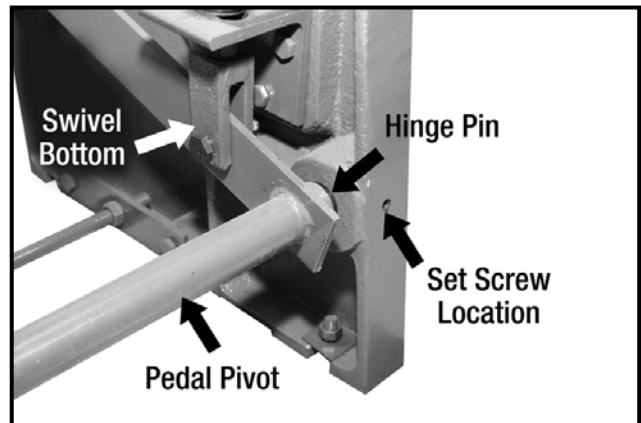

Figure-1 Foot pedal assembly

## FRONT EXTENSION ARMS

TO INSTALL THE FRONT EXTENSION ARMS:

Loosen the four bolts on the front table.

Place the front extension arms over the bolts and behind the special washers.

Align the channel of the front extension arm with the channel on the side.

Make sure the ground flat surface on the front extension arms are flush with the top of the table surface.

Tighten the bolts and check to make sure your alignments are still intact. See figure-2.

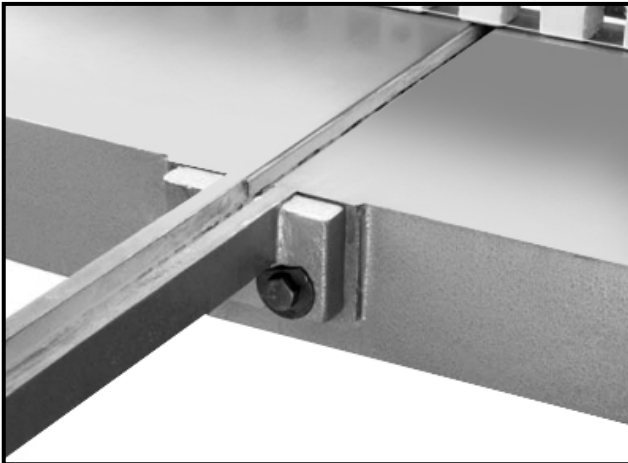

Figure-2 Front extension arm

## REAR EXTENSION ARMS

Slide the rear extension arms into the socket on the back of the table with the scales face.

Tighten the set screws.

Attach the rear stop to the rear extension bars and secure with the thumb screws provided. See figure-3.

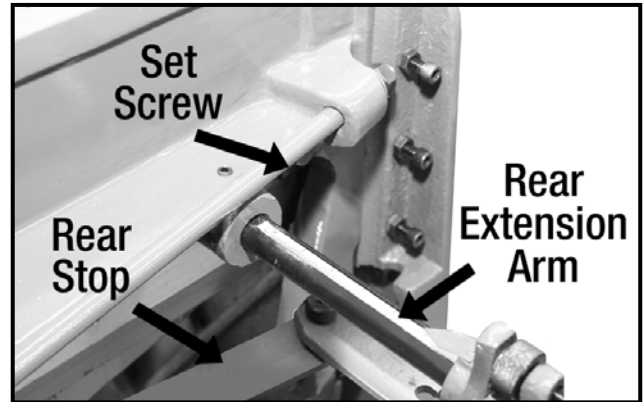

Figure-3 Installing rear extension arm

## HOLD DOWN ADJUSTMENT

TO ADJUST THE HOLD DOWN:

Tighten the hex nut on the top of the spring to raise the hold down off the table.

Insert the shim under the hold down finger, turn the hex nut to lower the hold down until it makes light contact with the shim.

Repeat the above steps at the other sides of the shear.

Tighten the two fixing bolts on the front of the hold down securing it in place. See figure-4.

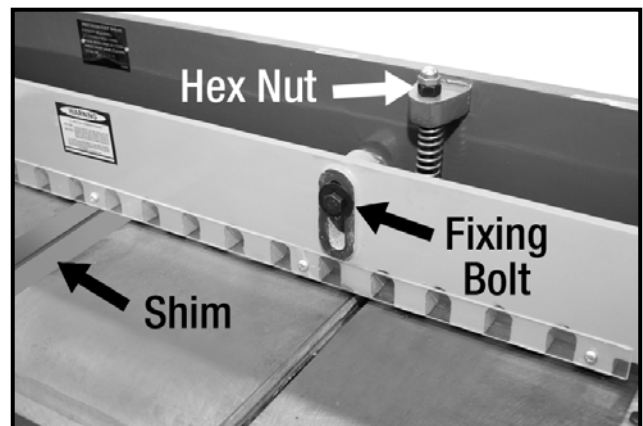

Figure-4 Adjusting the hold down

Recheck the gap to make sure the distance is equal across the length of the hold down.

## BLADE ADJUSTMENT

The blade adjustment has been made at the factory before shipment. However, you may find it necessary to check the blade adjustment before operation.

TO PERFORM THE BLADE SET UP:

Loosen the two table bolts and table adjustment screws on both sides of the machine. See figure-5.

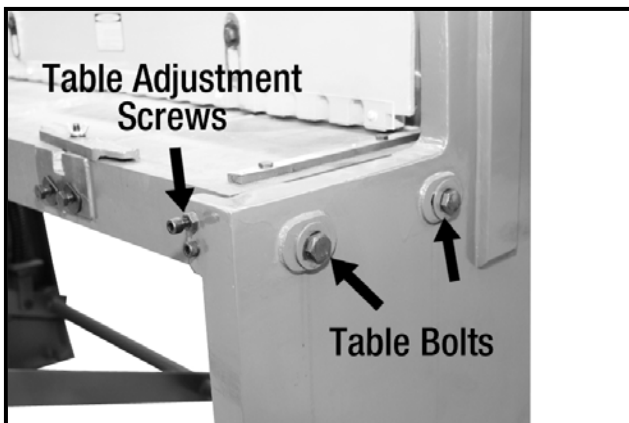

Figure-5 Table adjustment

Lower the blade and hold it in position using the foot pedal.

Now, turn the table adjustment screws to move the table and fixed blade until the fixed blade makes light contact with the moving blade all the way across the length. Make sure the moving blade does not overlap the fixed blade or it will cause damage.

Use a sheet of paper and make several cuts along the length of the blade. The shear should cut through the paper cleanly.

Turn the table adjustment screws moving the fixed blade away from the moving blade

so that you have a gap of 0.002". Check this measurement with a feeler gauge.

Repeat the same step on the other side of the machine so that gap is even across the length of the blade.

Tighten the four leg bolts and make sure it has not changed.

## ADJUSTING BLADE BOW

The bow of the moving blade is adjusted by loosening or tightening the bow bolt at the center of the straightening rod. Check if there is a change in the gap when the moving blade is just below the top of the fixed blade. After making adjustments to the bow, repeat the blade adjustment section.

- If the shear cuts paper on the ends but not the center, turn the bow bolt clockwise until paper is cut across the length.
- If the shear cuts paper at the center but not the ends, turn the bow bolt counter-clockwise until the paper is cut across the length.

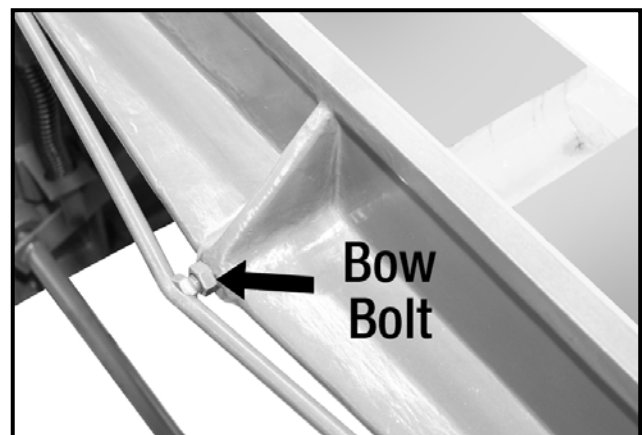

Figure-6 Adjusting the bow bolt



## FINGER GUARD

The CX817 features a plastic guard fixed to the front of the hold down. Do not remove under any circumstances. It will keep your fingers out of the blade.

### **WARNING!**

*Do not remove the finger guard under any circumstances.*

## STOPS & GUIDES

The wing nuts on the top of the stops allow adjusting the front stop and angle guide quickly and easily. The rear extension arms have micro adjusting stops to fine tune your length. See figure-7.

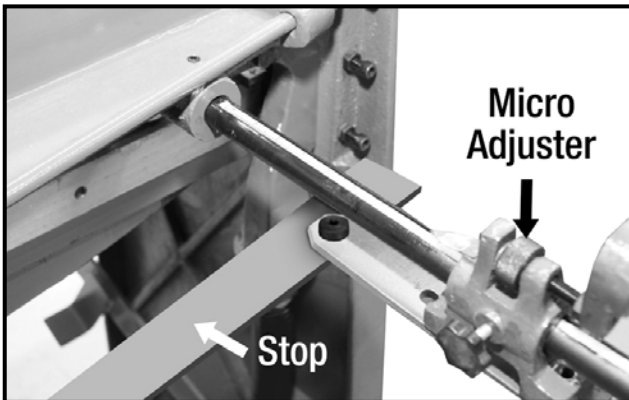

Figure-7 Micro adjusting stop

## BLADE CARE

The blade on the CX817 can be removed by loosening the eight hex bolts that secure the blade to the casting. See figure-6.

The moving blade has two cutting edges. You can rotate the blade to expose the new cutting edge as soon as one edge is dull. You can sharpen the blade very easily with a surface grinder.

The fixed blade has only cutting edge and it can also be sharpened by a surface grinder.

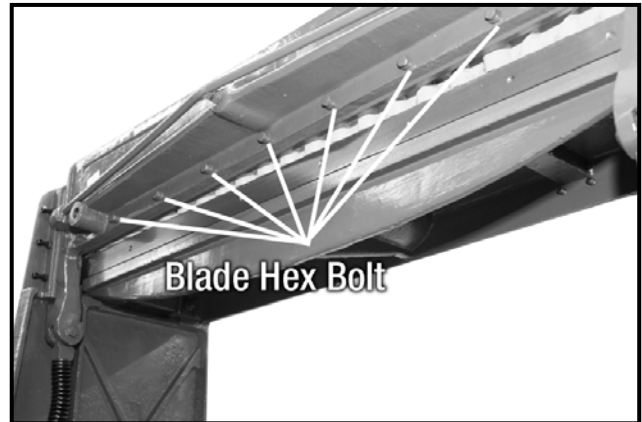

Figure-8 Blade bolts and return spring

## RETURN SPRING TENSION

The return spring can be adjusted on the foot lever. To increase the return rate, tighten the hex nuts against the spring shown in figure-9.

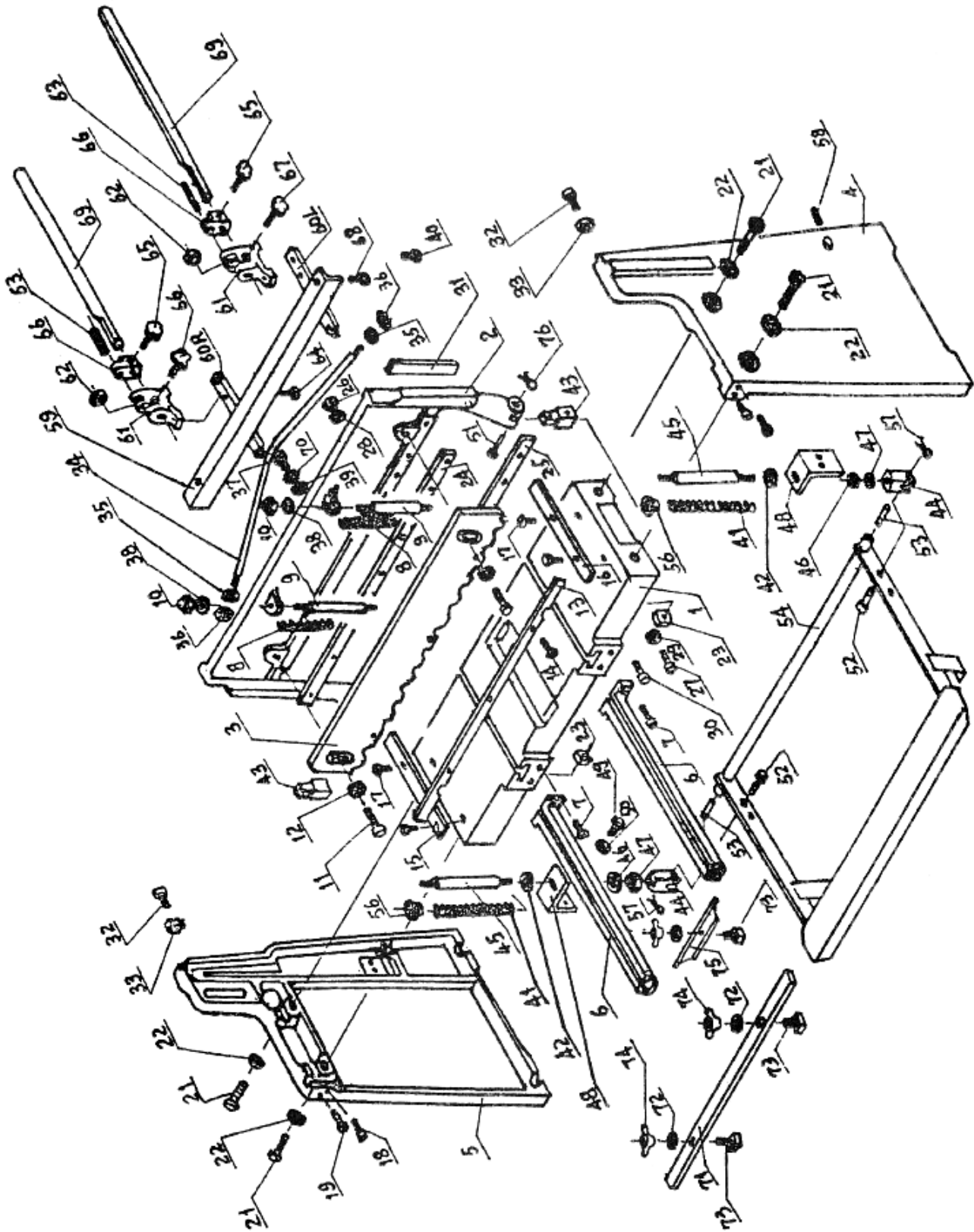

Figure-9 Return spring tension

## LUBRICATION

Lubricate all pivot and sliding points on the shear daily after use. Apply a thin coat of oil on the blades and other bare cast iron surfaces to prevent from rusting.

# PARTS DIAGRAM



# PARTS LIST

PART#	DESCRIPTION	QTY	PART#	DESCRIPTION	QTY
1	Work Table	1	39	Washer	1
2	Frame	1	40	Screw	2
3	Pressing plate	1	41	Spring	2
4	Right Stand	1	42	Washer	2
5	Left Stand	1	43	Upper Connecting Block	2
6	Connecting Rod	2	44	Lower Connecting Block	2
7	Screw	4	45	Bolt	2
8	Spring	2	46	Washer	2
9	Bolt	2	47	Nut	2
10	Nut	2	48	Connecting Plate	2
11	Screw	2	49	Bolt	4
12	Washer	2	50	Washer	4
13	Protecting Board	1	51	Upper Pin	2
14	Screw	3	52	Lower Pin	2
15	Workpiece Stop	2	53	Small Shaft	2
16	Gauge	2	54	Foot Stand Frame	1
17	Screw	4	56	Lid	2
18	Bolt	2	57	Pin	2
19	Bolt	2	58	Screw	2
20	Bolt	2	59	Workpiece Stop	1
21	Bolt	2	60R	Right Fixing Plate	1
22	Washer	4	60L	Left Fixing Plate	1
23	Nut	4	61	Find Adjustment Stand	2
24	Upper Blade	1	62	Adjusting Nut	2
25	Lower Blade	1	63	Bolt Shaft	2
26	Screw	8	64	Bolt	2
27	Screw	9	65	Small Screw	2
28	Washer	8	66	Large Screw	1
29	Washer	9	67	Large Screw	1
30	Screw	4	68	Bolt	2
31	Sliding plate	2	69	Gauge Shaft	2
32	Screw	6	70	Nut	1
33	Nut	6	71	Workpiece Pushing Plate	1
34	Strengthening Rod	1	72	Washer	3
35	Washer	2	73	T-style Bolt	3
36	Nut	2	74	Wing Nut	3
37	Adjusting Bolt	1	75	Small workpiece Pushing Plate	1
38	Washer	2	76	Pin	2



## WARRANTY

### CRAFTEX 3 YEARS LIMITED WARRANTY

Craftex warrants every product to be free from defects in materials and agrees to correct such defects where applicable. This warranty covers **three years** for parts and 90 days for labour (unless specified otherwise), to the original purchaser from the date of purchase but does not apply to malfunctions arising directly or indirectly from misuse, abuse, improper installation or assembly, negligence, accidents, repairs or alterations or lack of maintenance.

*Proof of purchase is necessary.*

All warranty claims are subject to inspection of such products or part thereof and Craftex reserves the right to inspect any returned item before a refund or replacement may be issued.

This warranty shall not apply to consumable products such as blades, bits, belts, cutters, chisels, punches etceteras.

Craftex shall in no event be liable for injuries, accidental or otherwise, death to persons or damage to property or for incidental contingent, special or consequential damages arising from the use of our products.

### RETURNS, REPAIRS AND REPLACEMENTS

To return, repair, or replace a Craftex product, you must visit the appropriate Busy Bee Tools showroom or call 1-800-461-BUSY. Craftex is a brand of equipment that is exclusive to Busy Bee Tools.

For replacement parts directly from Busy Bee Tools, for this machine, please call 1-800-461-BUSY (2879), and have your credit card and part number handy.

- All returned merchandise will be subject to a minimum charge of 15% for re-stocking and handling with the following qualifications.
- Returns must be pre-authorized by us in writing.
- We do not accept *collect* shipments.
- Items returned for warranty purposes must be insured and shipped pre-paid to the nearest warehouse
- Returns must be accompanied with a copy of your original invoice as proof of purchase. Returns must be in an un-used condition and shipped in their original packaging a letter explaining your reason for the return. Incurred shipping and handling charges are not refundable.
- Busy Bee will repair or replace the item at our discretion and subject to our inspection.
- Repaired or replaced items will be returned to you pre-paid by our choice of carriers.
- Busy Bee reserves the right to refuse reimbursement or repairs or replacement if a third party without our prior authorization has carried out repairs to the item.
- Repairs made by Busy Bee are warranted for 30 days on parts and labour.
- Any unforeseen repair charges will be reported to you for acceptance prior to making the repairs.
- The Busy Bee Parts & Service Departments are fully equipped to do repairs on all products purchased from us with the exception of some products that require the return to their authorized repair depots. A Busy Bee representative will provide you with the necessary information to have this done.
- For faster service it is advisable to contact the nearest Busy Bee location for parts availability prior to bringing your product in for repair.