



**CT023N, CT019N, CT028N, CT022N, CT026N
DRILL PRESSES
OWNER'S MANUAL**



COPYRIGHT © 2005 BY CRAFTEX INDUSTRIES INC.

NO PORTION OF THIS MANUAL MAY BE REPRODUCED WITHOUT THE WRITTEN CONSENT OF CRAFTEX INDUSTRIES INC.



TABLE OF CONTENTS

GENERAL SAFETY INSTRUCTIONS	PAGE 3
SPECIFIC SAFETY INSTRUCTIONS	PAGE 4
Features	PAGE 5
Electrical Information	PAGE 6
Unpacking & Cleaning	PAGE 7
Assembly	
Base to Column	PAGE 8
Table to Column	PAGE 8
Drill Press Head to Column	PAGE 9
Feed Handle	PAGE 9
Pulley Cover	PAGE 10
Arbor and Chuck	PAGE 10
Removing the Chuck	PAGE 10
Mounting the Drill Press	PAGE 10
Adjustments	
Changing Spindle Speeds	PAGE 11
Table Adjustments	PAGE 11
Drilling Depth	PAGE 12
Spindle Return Spring	PAGE 12
Operation	
Drilling Speeds	PAGE 13
Metalworking	PAGE 13
Woodworking	PAGE 13
Feeding	PAGE 13
Laser Operation	PAGE 14
Maintenance	PAGE 15
Schematic Diagram for CT019N, CT022N & CT026N	PAGE 16
Parts List	PAGE 17
Schematic Diagram for CT023N & CT028N	PAGE 19
Parts List	PAGE 20
Warranty	PAGE 22

GENERAL SAFETY INSTRUCTIONS

EXTREME CAUTION SHOULD BE USED IN OPERATING ALL POWER TOOLS. KNOW YOUR POWER TOOL, BE FAMILIAR WITH ITS OPERATION. READ THE OWNER'S MANUAL AND PRACTICE SAFE USAGE PROCEDURES AT ALL TIMES.

- ❑ **CONNECT** your machine **ONLY** to the matched and specified power source.
- ❑ **WEAR SAFETY GLASSES, HEARING PROTECTION** and **SAFETY SHOES** when operating heavy machinery. Always wear safety glasses.
- ❑ **DO NOT** wear loose clothing or jewellery when operating machinery.
- ❑ **A Safe Environment is important.** Keep the area free of dust, dirt and other debris in the immediate vicinity of the machine.
- ❑ **BE ALERT!** Do Not Use prescription or other drugs that may affect your ability or judgement to safely use this machine.
- ❑ **DISCONNECT** the power source when making other adjustments or repairs.
- ❑ **NEVER** leave an operating tool unattended.
- ❑ **NEVER** reach over the table when the tool is in operation.
- ❑ **ALWAYS** keep blades, knives or bits sharp and properly aligned.
- ❑ **ALWAYS** keep all safety guards in place and ensure their proper function.
- ❑ **ALWAYS** make sure that any tools used for adjustments are removed before operating the machine.
- ❑ **ALWAYS** secure your work with the appropriate clamps or vises.
- ❑ **ALWAYS** keep bystanders safely away while operating machinery.
- ❑ **THINK SAFETY. WORK SAFELY.** Never attempt a procedure if it does not feel safe or comfortable.

SPECIFIC SAFETY INSTRUCTIONS

- ❑ Always make certain that you clamp down any object that you are drilling into.
- ❑ When drilling, make sure that you are using the correct speed for the material being drilled.
- ❑ Clear the drill press table of all objects before turning the tool on.
- ❑ Keep hands and fingers safely away from the spinning drill bits.
- ❑ NEVER start the drill press with the drill bit in contact with the work-piece.
- ❑ Make certain that the drill bit is securely tightened into the drill chuck.
- ❑ NEVER wear gloves while operating a drill press.
- ❑ Make certain that the table lock is securely tightened before using the drill press.
- ❑ Never attempt to drill any material that is not flat without using a secure jig for that specific work-piece.
- ❑ Always remove the drill bit before leaving the machine.

DRILL PRESS FEATURES

As part of the growing line of Craftex woodworking equipment, we are proud to offer the CT023N, CT019N, CT028N, CT022N, CT026N Drill Presses. The Craftex name guarantees Craft Excellence. By following the instructions and procedures laid out in this owner's manual, you will receive years of excellent service and satisfaction. The CT023N, CT019N, CT028N, CT022N, CT026N are professional tools and like all power tools, proper care and safety procedures should be adhered to.

CT023N

Size: 13"
Motor: 1/2 HP
Chuck: 5/8"
Spindle: MT2
Table: 10" SQ.
Speeds: 12
Height: 38"
Weight: 57 kg.
Carton size: 19" x
10" x 30"

CT019N

Size: 14"
Motor: 3/4 HP
Chuck: 5/8"
Spindle: MT2
Table: 11 1/4" SQ.
Speeds: 12
Height: 38"
Weight: 73 kg.
Carton size: 20" x 9"
x 32"

CT028N

Size: 13"
Motor: 1/2 HP
Chuck: 5/8"
Spindle: MT2
Table: 10" SQ.
Speeds: 12
Height: 62"
Weight: 66 kg.
Carton size: 20" x 10"
x 56"

CT022N

Size: 14"
Motor: 3/4 HP
Chuck: 5/8"
Spindle: MT2
Table: 11 1/4" SQ.
Speeds: 12
Height: 64"
Weight: 86 kg.
Carton size: 20" x 10" x
56"

CT026N

Size: 20"
Motor: 1 1/2 HP
Chuck: 5/8"
Spindle: MT4
Table: 18 3/4" x 16 3/4"
Speeds: 12
Height: 67"
Weight: 148 kg.
Carton size: 29" x 13" x
56"

These 5 presses feature Rack & Pinion raising mechanism that gives smooth and accurate movement of the drill press. The full cast iron table tilt, allowing for a variety of drilled holes.

The operational handles are all made of solid cast iron and feature comfort rubber grip pads for ease of use.

Each of these drill presses also feature built in laser guiding technology. This can come in handy when doing single cuts, but more so when repetitive cuts are in order. See page 14 for more details.

GROUNDING INSTRUCTIONS

In the event of a malfunction or breakdown, grounding provides the path of least resistance for electrical current and reduces the risk of electrical shock. This tool is equipped with an electrical cord that has an equipment grounding conductor and a grounding plug. The plug **MUST** be plugged into a matching outlet that has been properly installed and grounded in accordance with **ALL** local codes and ordinances.

DO NOT MODIFY THE PLUG PROVIDED. If the provided plug will not fit the electrical outlet, have the proper outlet installed by a qualified licensed electrician.

IMPROPER CONNECTION of the equipment grounding conductor can result in risk of electrical shock. The conductor wire with the green insulation (with or without yellow stripes) is the equipment-grounding conductor. If repair or replacement of the electrical cord or plug is required, **DO NOT** connect the equipment grounding conductor to a live terminal.

If in doubt about these instructions consult a qualified, licensed electrician.

USE ONLY A THREE-WIRE EXTENSION CORD with a 3-prong grounding plug and three-hole receptacles that accept the tool's plugs as shown.

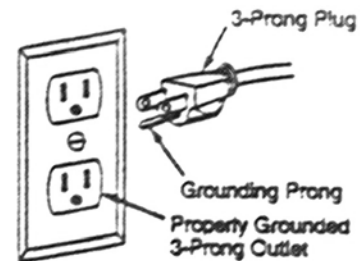

It is recommended that stationary tools be assigned to a dedicated 15 amp circuit using #12 wire.

UNPACKING AND CLEANING

Carefully unpack your drill press and all of its parts. Compare the carton contents with the illustration below. Do not discard any packing material until the drill press is completely assembled and operating properly.

Your drill press and some of its parts have been coated with a protective lubricant that should be removed before the machine is assembled. This can be done with a soft cloth moistened with non-corrosive kerosene or mineral spirits.

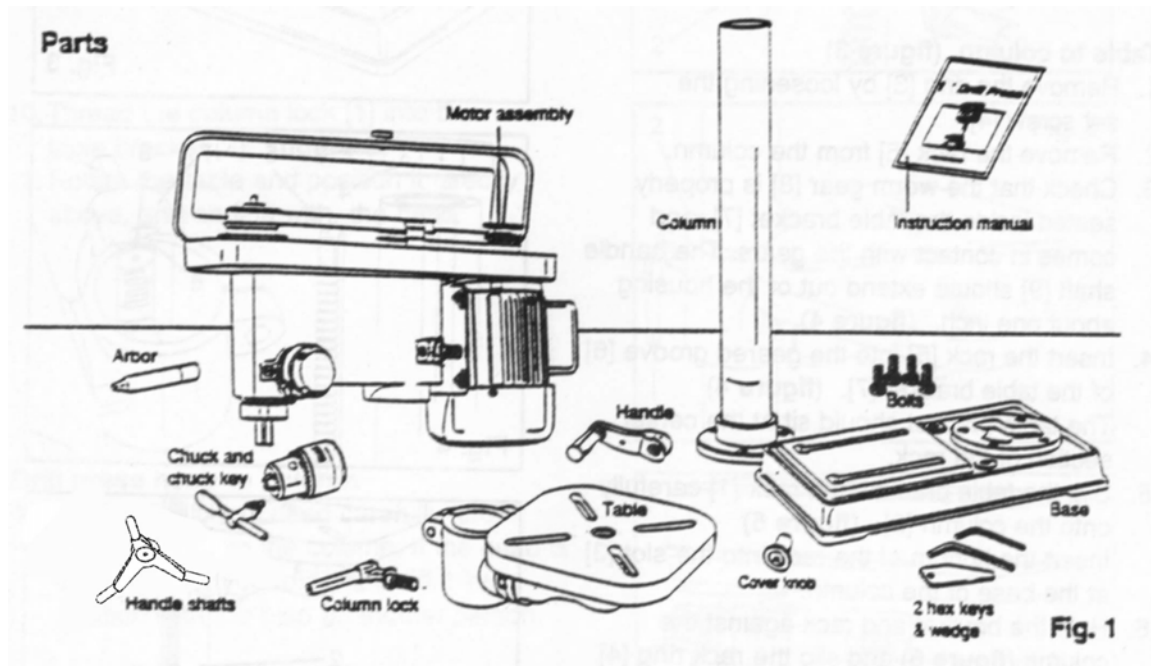

ASSEMBLY

BASE TO COLUMN

Select the base and the drill press column from the loose parts. Select the four 10mm x 25mm bolts from the parts bag. Align the holes of the post flange to the threaded holes in the base. Insert the bolts and tighten securely.

TABLE TO COLUMN

Remove the ring (3) by loosening the set-screw (4). Remove the rack (5) from the column.

Check that the worm gear (8) is properly seated inside the table bracket (7) and it comes in contact with the gears. The handle shaft (9) should extend out of the housing by about 1".

Insert the rack (5) into the geared groove (6) of the table bracket (7). The table bracket should sit at the center section of the rack.

Slip the table bracket and rack (1) carefully onto the column (2). Insert the bottom of the rack into the slot (3) at the base of the column.

Hold the bracket and rack against the column and slip the rack ring (4) onto the column.

The rack (1) fits under the rack ring (4). Make sure there is enough clearance between the rack and the ring to allow the table to rotate around the column.

Tighten the set-screw (5) to hold the ring in position.

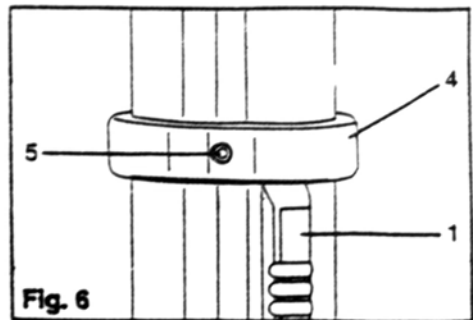
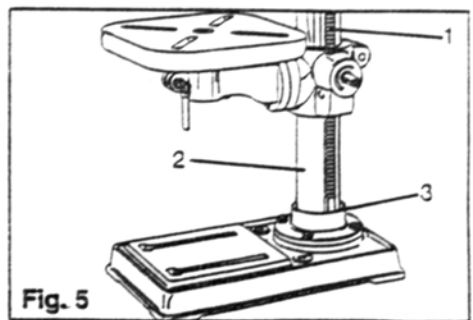
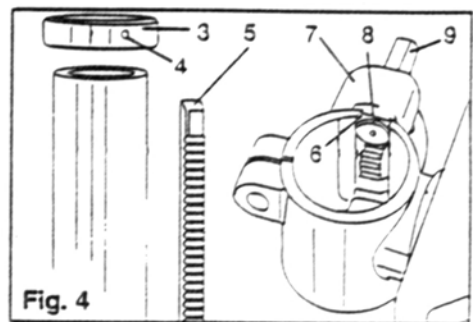
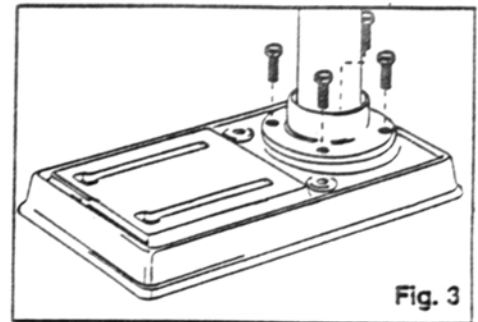

ASSEMBLY

Attach the elevation handle by tightening the set-screw (2)

Thread the column lock into the table bracket (1).

Rotate the table and position it directly over and in line with the base.

DRILL PRESS HEAD TO COLUMN.

Lift the drill press head carefully and position it above the column. NOTE: this may require the help of a second person.

The column fits into the drill press mounting hole. Make certain the mounting hole is properly seated on the column. Line the drill press head up with the table and base and then tighten the two set-screws using the supplied hex wrench.

FEED HANDLE.

Fit the one-piece cast-iron feed handle onto the shaft.

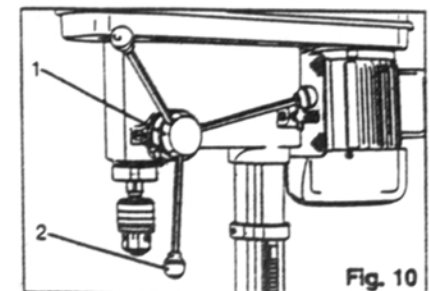
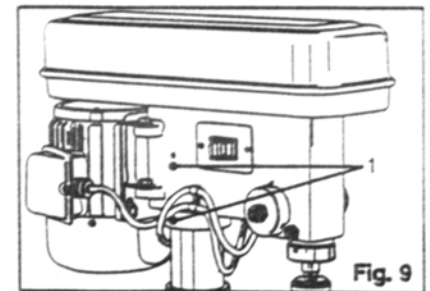
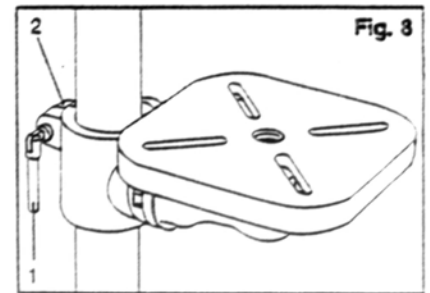
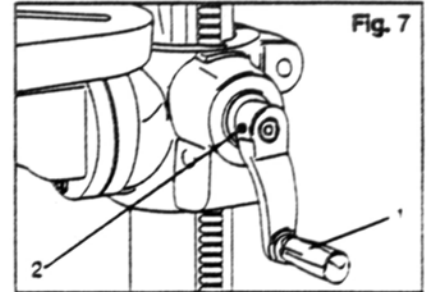

ASSEMBLY

PULLEY COVER

Insert washer and screw through the hole in the pulley cover, thread the knob onto the screw and then tighten.

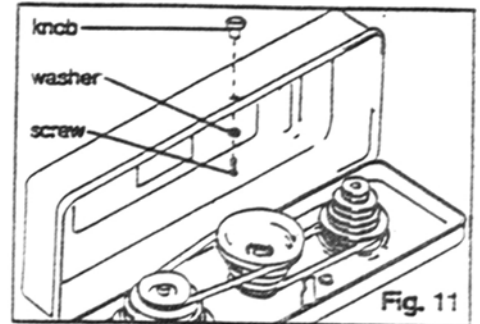

INSTALLING THE ARBOR AND CHUCK

Slide the long end of the arbor (1) into the spindle (2) as far as it will go.

Slide the chuck (3) onto the arbor and then place a block of wood under the chuck and tap the chuck and arbor with a hammer until it seats into the spindle. DO NOT STRIKE THE CHUCK DIRECTLY WITH A STEEL HAMMER.

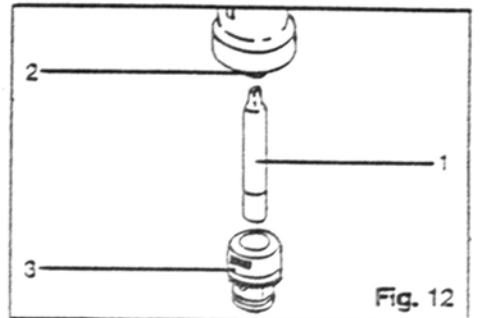

REMOVING THE CHUCK

Lower the chuck to its lowest position exposing the spindle sleeve (1).

The spindle sleeve has a large oval hole (2) on both sides of it.

Rotate the chuck (3) until the spindle hole (4) lines up with the hole in the spindle sleeve.

Insert the wedge (5) and tap the wedge lightly with a hammer.

The arbor and the chuck will release from the spindle.

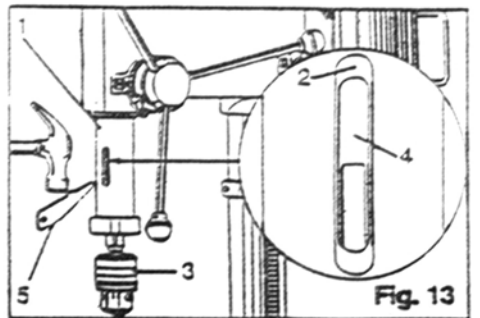

MOUNTING THE DRILL PRESS

Your drill press must be securely fastened to the floor to prevent the machine from tipping, sliding or walking during operation. There are two base holes provided for this.

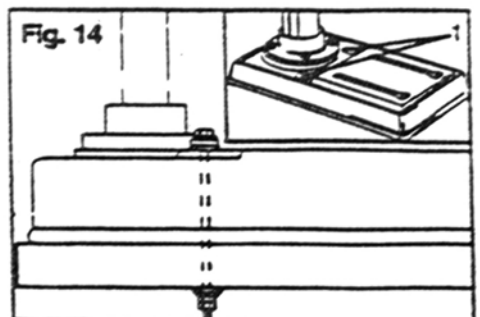

ADJUSTMENTS

CHANGING SPINDLE SPEEDS

Disconnect the drill press from its power source.

Open the pulley cover.

Loosen the slide bar knob (1).

Move the motor to the front to loosen the tension on both belts.

Relocate the belts to the pulley steps appropriate to the required spindle speed (2).

To tighten the belt tension, move the motor toward the rear of the drill press.

Tighten the slide bar knob (1).

Close the pulley cover.

Test run the drill press to check the belts for proper tension.

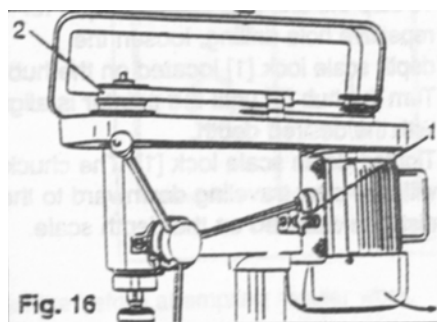

TABLE ADJUSTMENTS

Raise or lower the drill press table by loosening the column lock (1) and turning the rack and pinion handle (2) to the desired elevation. Securely tighten the column lock before using the drill press.

To rotate the table around the post, loosen the column lock. Secure the column lock before operating the tool.

To rotate the table only, loosen the table lock (3). Do not operate the drill press without tightening the table lock.

To tilt the table from 0 degrees to 45 degrees left or right, remove the pin (4) and nut (5). If the pin sticks, rotate the nut (5) clockwise until the pin slips out. Loosen the table locking bolt (6), tilt the table to the desired angle and tighten the bolt (6). When returning the table to 0 degrees, replace the pin (4) and tighten bolts (5) and (6).

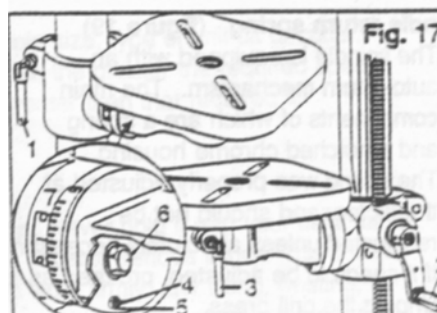

ADJUSTMENTS

DRILLING DEPTH

Your drill press has been equipped with a new type depth adjustment. To set the depth stop, loosen the depth locking nuts and rotate them to the desired depth as indicated on the scale.

SPINDLE RETURN SPRING

The spindle is equipped with an auto-return mechanism. The main components of which are a spring and a notched chrome housing. The spring was properly adjusted at the factory and should not be readjusted unless absolutely necessary. If required, proceed as follows:

- **Unplug the drill press.**
- Loosen the two housing nuts (1) approximately 1/4".
- Firmly hold the spring housing (2) and pull it out so it clears the raised notch (3).
- Turn it until the next notch is engaged with the boss. To increase the tension, turn it clockwise and counter-clockwise to decrease the tension.
- Tighten the two nuts.
- Do not over-tighten the nuts, as it will make the spindle handle sluggish.

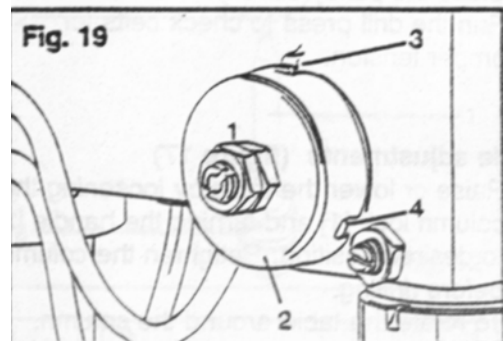
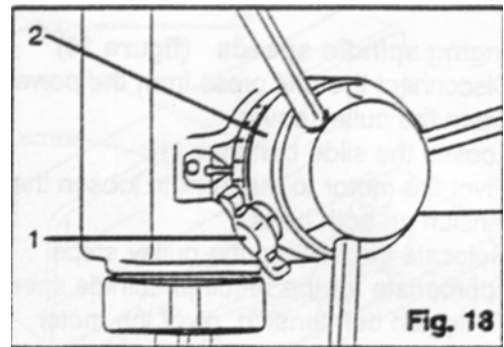

OPERATION

Note: As with any new piece of equipment, the owner/operator should use scrap material in order to become accustomed it.

DRILLING SPEEDS

The following is intended to be a general rule-of-thumb, not specific information.

Important drilling speed factors are the type of material, hole size, the type of drill bit/cutter and the desired cut quality. The smaller the drill bit, the higher the speed required and soft materials generally require a higher speed while hard materials a slower speed.

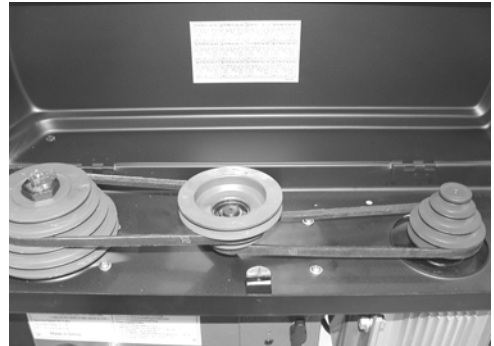

METAL WORKING

A metal workpiece (like all work) should be firmly clamped to the drill press table and the table securely locked. NEVER hold the workpiece with your bare hands. The drill bit may grab and cause serious personal injury. Flat metal pieces should be backed with scrap wood and clamped. Irregular-shaped pieces should be blocked and clamped.

WOODWORKING

Metal-piercing twist drills may be used on wood but the preferred choice is brad-point bits or Forstner-type bits.

Do not use auger bits, as they will tend to lift off the table.

To prevent tear-out when drilling through a workpiece, back it with a piece of scrap wood.

FEEDING

Be aware of the sound of the drill press motor when drilling.

Do not rotate the feed handles too quickly as the belts may slip or the motor may stall.

Feeding too slowly may cause the drill bit to heat up and possibly burn the workpiece.

OPERATION

LASER OPERATION

CAUTION: THE LASER LIGHT MAY SERIOUSLY HARM YOUR EYES IF THE BEAM IS AIMED DIRECTLY AT THEM.

Your CT023N, CT019N, CT028N, CT022N or CT026N drill press is equipped with a laser to assist in accurate drilling in single or repetitive drilling operations.

The laser projector is located under the drill press head, just behind the shaft and chuck.

The laser projects an 'X' onto the drill press table and the projector itself may be moved like a joystick. This may be re-aimed.

The best way of correctly aiming the laser beam is to install the drill bit you intend to use into the chuck.

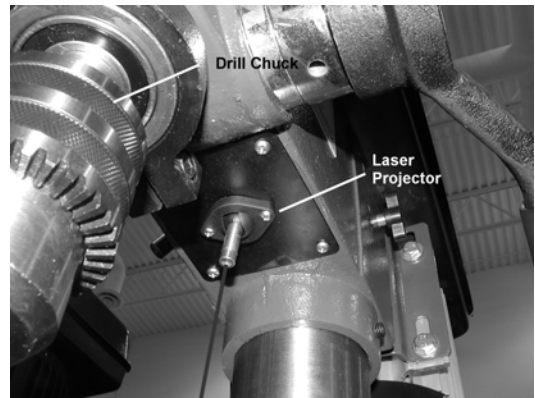

Use a piece of scrap wood on the drill press table.

Lower the drill bit so that it touches the scrap wood.

Aim the laser so that the center of the "X" is intersected by drill bit. If the drill bit interferes with the laser beam, press the point of the bit into the scrap and that mark should be in the center of the "X".

As long as the drill press table remains in that position the laser beam will remain as the target.

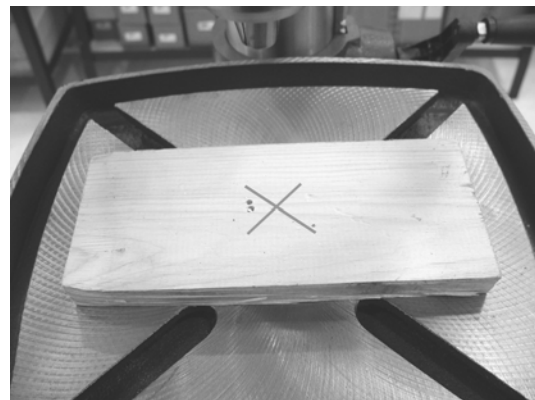

MAINTENANCE

Disconnect the Power Cord before Working on the Machine

Although machines such as this drill press are designed to work in wood shops and metal shops, sawdust and metal shavings are not friendly to electrical motors.

The owner should routinely (once a month) blow out or vacuum metal shavings and sawdust from the motor cover, the pulley housing, the drill press table and other surfaces.

The drill press table should be cleaned after each use.

The application of a light coat of paste wax on drill press column and the table will help keep these surfaces clean and rust-free.

The bearings in the quill and V-belt assembly are permanently greased and sealed.

A light application of oil to the quill every three months is recommended.

Lubricate other moving parts such as the table swivel, tilt, rack and pinion etc. on a regular basis.

SCHEMATIC DIAGRAM FOR CT019N, CT022N & CT026N

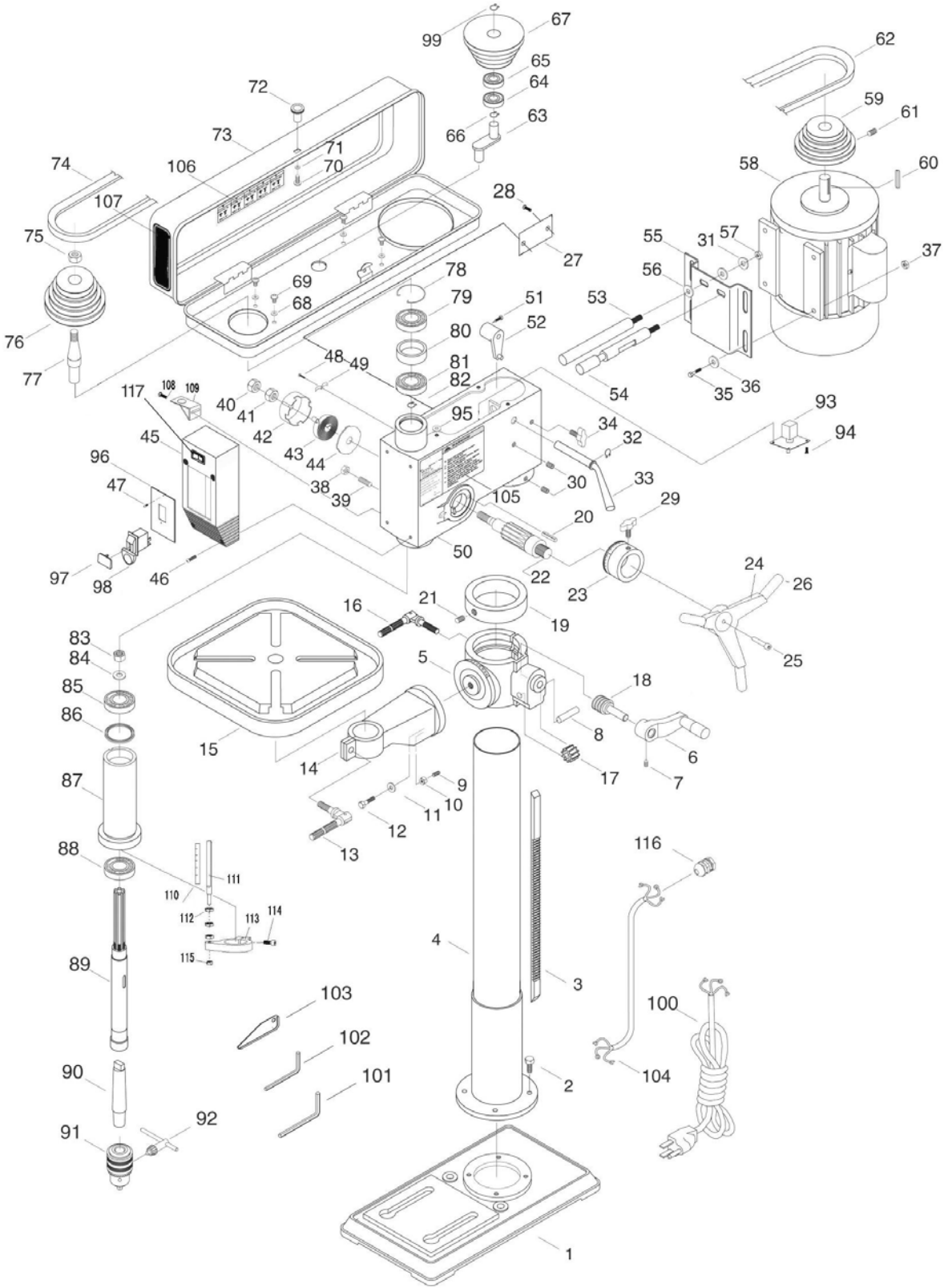

PARTS LIST FOR CT019N, CT022N & CT026N

PART #	DESCRIPTION	QTY	PART #	DESCRIPTION	QTY
001	Base	1	042	Spring cap	1
002	Hex bolt	4	043	Torsion spring	1
003	Rack	1	044	Spring cover	1
004	Column	1	045	Switch box	1
005	Table bracket	1	046	Screw	4
006	Handle	1	047	Screw	2
007	Setscrew	1	048	Screw	1
008	Shaft	1	049	Clamp cord	1
009	Pin	1	050	Body	1
010	Nut	1	051	Hex bolt	1
011	Washer	1	052	Shifter	1
012	Hex bolt	1	053	Slide bar	1
013	Table bolt	1	054	Slide bar	1
014	Table arm bracket	1	055	Motor base	1
015	Table	1	056	Washer	1
016	Clamp bolt	1	057	Nut	2
017	Gear	1	058	Motor	1
018	Worm gear	1	059	Motor pulley	1
019	Rack ring	1	060	Key	1
020	Pin stop	1	061	Setscrew	1
021	Set screw	1	062	V-belt	1
022	Feed shaft	1	063	Center shaft	1
023	Depth ring	1	064	Ball bearing	1
024	Handle	1	065	Ball bearing	1
025	Bolt	1	066	C-clip	1
026	Handle cap	3	067	Center pulley	1
027	Plate	1	068	Washer	4
028	Bolt	2	069	Screw	4
029	Slide bar bolt	1	070	Screw	1
030	Setscrew	2	071	Washer	1
031	Lock washer	2	072	Knob	1
032	C-clip	1	073	Pulley cover	1
033	Shift bar	1	074	V-belt	1
034	Slide bar bolt	2	075	Pulley nut	1
035	Hex bolt	4	076	Spindle pulley	1
036	Washer	4	077	Insert pulley	1
037	Nut	4	078	C-clip	1
038	Nut	1	079	Ball bearing	1
039	Screw special set	1	080	Spacer	1
040	Nut	1	081	Ball bearing	1
041	Nut	1	082	C-clip	1

PART #	DESCRIPTION	QTY	PART #	DESCRIPTION	QTY
083	Round nut	1	101	Wrench	1
084	Washer	1	102	Wrench	1
085	Ball bearing	1	103	Wedge	1
086	Rubber washer	1	104	Motor cord	1
087	Spindle sleeve	1	105	Label	1
088	Ball bearing	1	106	Speed label	1
089	Spindle	1	107	Brand label	1
090	Arbor	1	108	Bolt	2
091	Chuck	1	109	Support plate	1
092	Chuck key	1	110	Scale	1
093	Laser	1	111	Scale base	1
094	Bolt	2	112	Nut	2
095	Washer	4	113	Block	1
096	Switch base	1	114	Bolt	1
097	Key for switch	1	115	Nut	1
098	Switch	1	116	Wire gasket	1
099	C-clip	1	117	Laser ON/OFF Button only on (CT26N, CT022N, CT028N & CT019N)	
100	Pin & cable	1			

SCHEMATIC DIAGRAM FOR CT023N & CT028N

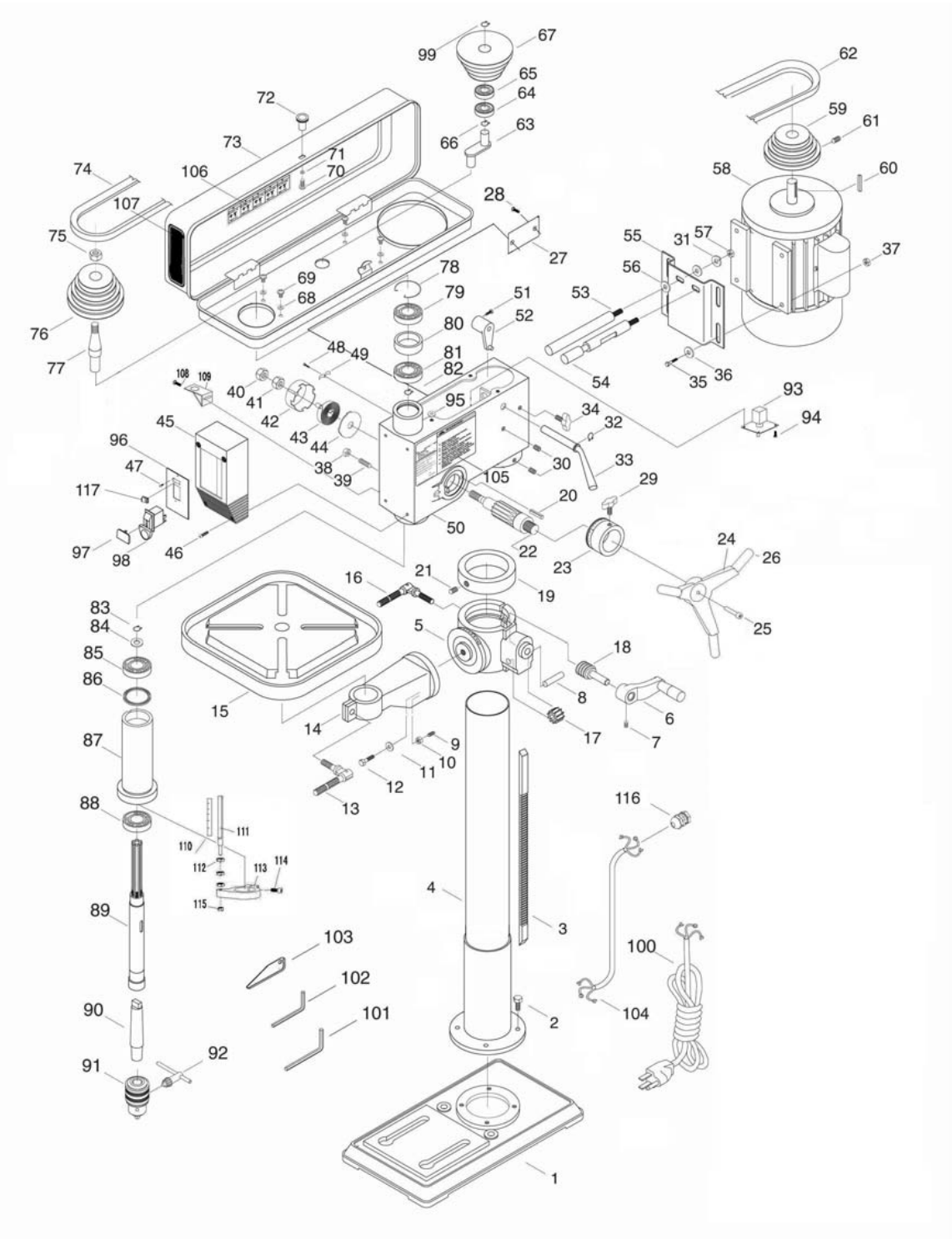

PARTS LIST FOR CT023N & CT028N

PART #	DESCRIPTION	QTY	PART #	DESCRIPTION	QTY
001	Base	1	042	Spring cap	1
002	Hex bolt	4	043	Torsion spring	1
003	Rack	1	044	Spring cover	1
004	Column	1	045	Switch box	1
005	Table bracket	1	046	Screw	4
006	Handle	1	047	Screw	2
007	Setscrew	1	048	Screw	1
008	Shaft	1	049	Clamp cord	1
009	Pin	1	050	Body	1
010	Nut	1	051	Hex bolt	1
011	Washer	1	052	Shifter	1
012	Hex bolt	1	053	Slide bar	1
013	Table bolt	1	054	Slide bar	1
014	Table arm bracket	1	055	Motor base	1
015	Table	1	056	Washer	1
016	Clamp bolt	1	057	Nut	2
017	Gear	1	058	Motor	1
018	Worm gear	1	059	Motor pulley	1
019	Rack ring	1	060	Key	1
020	Pin stop	1	061	Setscrew	1
021	Set screw	1	062	V-belt	1
022	Feed shaft	1	063	Center shaft	1
023	Depth ring	1	064	Ball bearing	1
024	Handle	1	065	Ball bearing	1
025	Bolt	1	066	C-clip	1
026	Handle cap	3	067	Center pulley	1
027	Plate	1	068	Washer	4
028	Bolt	2	069	Screw	4
029	Slide bar bolt	1	070	Screw	1
030	Setscrew	2	071	Washer	1
031	Lock washer	2	072	Knob	1
032	C-clip	1	073	Pulley cover	1
033	Shift bar	1	074	V-belt	1
034	Slide bar bolt	2	075	Pulley nut	1
035	Hex bolt	4	076	Spindle pulley	1
036	Washer	4	077	Insert pulley	1
037	Nut	4	078	C-clip	1
038	Nut	1	079	Ball bearing	1
039	Screw special set	1	080	Spacer	1
040	Nut	1	081	Ball bearing	1
041	Nut	1	082	C-clip	1

PART #	DESCRIPTION	QTY	PART #	DESCRIPTION	QTY
083	C-clip	1	101	Wrench	1
084	Washer	1	102	Wrench	1
085	Ball bearing	1	103	Wedge	1
086	Rubber washer	1	104	Motor cord	1
087	Spindle sleeve	1	105	Label	1
088	Ball bearing	1	106	Speed label	1
089	Spindle	1	107	Brand label	1
090	Arbor	1	108	Bolt	2
091	Chuck	1	109	Support plate	1
092	Chuck key	1	110	Scale	1
093	Laser	1	111	Scale base	1
094	Bolt	2	112	Nut	2
095	Washer	4	113	Block	1
096	Switch base	1	114	Bolt	1
097	Key for switch	1	115	Nut	1
098	Switch	1	116	Wire gasket	1
099	C-clip	1	117	Laser ON/OFF Button only on (CT26N, CT022N, CT028N & CT019N)	
100	Pin & cable	1			



WARRANTY

CRAFTEX 2 YEAR LIMITED WARRANTY

Crafttex warrants every product to be free from defects in materials and agrees to correct such defects where applicable. This warranty covers **two years** for parts and 90 days for labour (unless specified otherwise), to the original purchaser from the date of purchase but does not apply to malfunctions arising directly or indirectly from misuse, abuse, improper installation or assembly, negligence, accidents, repairs or alterations or lack of maintenance.

Proof of purchase is necessary.

All warranty claims are subject to inspection of such products or part thereof and Crafttex reserves the right to inspect any returned item before a refund or replacement may be issued.

This warranty shall not apply to consumable products such as blades, bits, belts, cutters, chisels, punches etceteras.

Crafttex shall in no event be liable for injuries, accidental or otherwise, death to persons or damage to property or for incidental contingent, special or consequential damages arising from the use of our products.

RETURNS, REPAIRS AND REPLACEMENTS

To return, repair, or replace a Crafttex product, please contact your nearest Busy Bee Tools (or contact Head Office). Crafttex is a brand of equipment that is exclusive to Busy Bee Tools. For replacement parts directly from Busy Bee Tools, for this machine, please call 1-800-461-BUSY(2879), and have your credit card and part number handy.

- All returned merchandise will be subject to a minimum charge of 15% for re-stocking and handling with the following qualifications.
- Returns must be pre-authorized by us in writing.
- **We do not accept collect shipments.**
- Items returned for warranty purposes must be insured and shipped pre-paid to the nearest warehouse
- Returns must be accompanied with a copy of your original invoice as proof of purchase. Returns must be in an un-used condition and shipped in their original packaging and a letter explaining your reason for the return. Incurred shipping and handling charges are not refundable.
- Busy Bee will repair or replace the item at our discretion and subject to our inspection.
- Repaired or replaced items will be returned to you pre-paid by our choice of carriers.
- Busy Bee reserves the right to refuse reimbursement or repairs or replacement if a third party without our prior authorization has carried out repairs to the item.
- Repairs made by Busy Bee are warranted for 30 days on parts and labour.
- Any unforeseen repair charges will be reported to you for acceptance prior to making the repairs.
- The Busy Bee Parts & Service Departments are fully equipped to do repairs on all products purchased from us with the exception of some products that require the return to their authorized repair depots. A Busy Bee representative will provide you with the necessary information to have this done.
- For faster service it is advisable to contact the nearest Busy Bee location for parts availability prior to bringing your product in for repairs.