

## 1 SELECTING THE MODE CONFIGURATION

1

### STEP 1

- Loosen both screws on side of lock body.
- With some force, slide screws in direction required until stop at end of slot is reached.
- Hold in position and re-tighten screws.



### STEP 2

- Rotate Latch Plate screw beneath the red re-sealable sticker according to orientation shown below:



Turn counter-clockwise 180° for Power-to-Open (Fail Secure)



Turn clockwise 180° for Power-to-Lock (Fail Safe)

### STEP 3

- Change jumper position on Printed Circuit Board beneath the red re-sealable sticker as shown below:



Power-to-Open (Fail Secure)



Power-to-Lock (Fail Safe)

Bolt Label

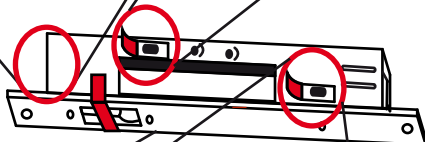

## WARNING!

- Lock mode configuration set to Power To Lock (Fail Safe). Ensure the correct mode is set before applying power: you may be charged for incorrect installation.
- Discard Bolt Label once correct mode is selected.
- If the lock had been installed or previously operated, the latch plate screw (STEP 2) will not be visible. To change lock mode configuration, contact your distributor for additional information.
- Ensure all re-sealable stickers and screws are re-attached after configuration to prevent ingress of dust.

## SPECIFICATIONS AND NOTES

Parameter	Specification
Door Gap	Ideally 3mm to 8mm only. 8mm maximum.
Lock Monitor Output	Voltage free changeover switch contacts rated for 48VDC / 100mA
Holding Force	AS4145.2 - 1993; Passed S3 (611kg for 1 minute) Capable of 1000kg if strike plate is fully supported
Release under Side Load	15kg max at bolt with motorised unlocking (3 wire control) 3kg max at bolt with Power-To-Lock (Fail Safe) unlocking and 2 wire control
Bolt Dimensions	Diameter = 11mm Projection = 20.5mm
Power Supply (12-24VDC)	Regulation better than +/- 2% 1Amp Power supply required
Current Draw	Power to Lock holding current 130mA Power to Open holding current 30mA Initial locking and unlocking current draw higher
Misalignment tolerance	+/- 3.5mm
Operating Temperature	-10°C to +50°C at 90% RH
Durability	> 300,000 cycles
Certifications	<ul style="list-style-type: none"> <li>•Up to 2-hour fire rating depending on doorset used; in accordance with AS1905.1 - 1997, Part 1: Fire Resistant Doors</li> <li>•CE compliant</li> <li>•SCEC endorsed (high security strike bracket required)</li> </ul>

- V-Lock must ONLY be used in weather protected areas.
- V-Lock can ONLY be installed vertically or horizontally ABOVE the door (not on or under the floor).
- V-Lock WILL NOT operate without strike plate. Strike plate MUST be correctly aligned and in front of the (M) logo on the faceplate.

## 2 DOOR PREPARATION FOR STRIKE AND JAMB

2

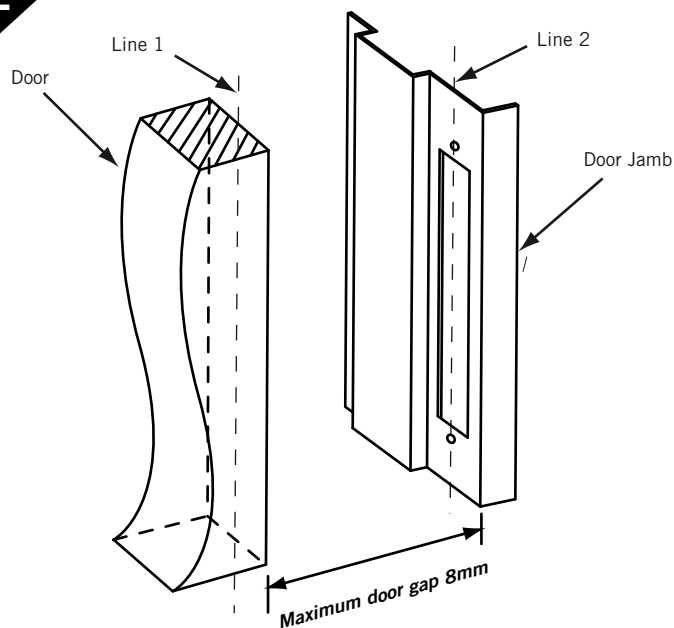

- Before starting with the installation make sure the gap between the door and the door jamb does not exceed 8mm
- Mark Line 1 corresponding to mid-plane of Door
- Mark Line 2 corresponding with Line 1 on the Door Jamb

Note: Make sure the Line 1 and Line 2 are aligned when the door is in the closed position.

## 3 DOOR JAMB PREPARATION

3

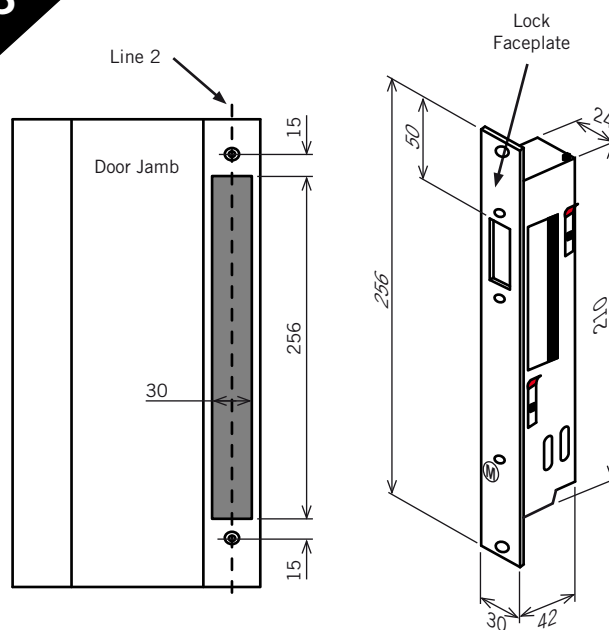

- Mark cutout of V-Lock symmetrically about Line 2.
- Cutout size for faceplate must be 256mm x 30mm
- Prepare door jamb appropriately as shown.

Note: Thickness of faceplate - 3mm

# ELECTRICAL SPECIFICATION

## 3 Wire Control

### Power To Open (PTO) Wiring Connections

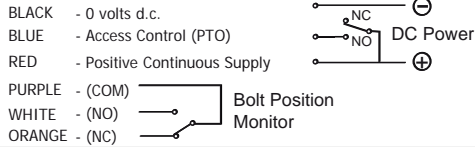

### Power To Lock (PTL) Wiring Connections

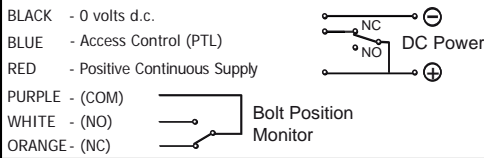

## 2 Wire Control

### Power To Lock 2 Wire Control - NOT RECOMMENDED

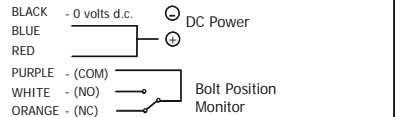

The V-Lock is designed to be controlled with a minimum of 2 wires. However, it is recommended that 3 wire control be used:

### 3 Wire Control:

- Positive voltage should be connected to the RED wire providing permanent power.
- Negative voltage should be connected to the BLACK wire.
- Positive voltage should be connected to the BLUE wire providing a lock/unlock signal.
- When connected with 3 wires the motor will provide power assisted unlocking allowing the bolt to retract with up to 15kg of side load.
- Voltage-free changeover switch contacts are provided for bolt position monitoring.
- When locked, the monitor switch (COM - PURPLE) is connected to (NC - ORANGE).
- The V-Lock is multi-voltage and operates with either 12 to 24VDC power.
- The V-Lock has in-built Reverse Polarity Protection for installer safety.

### 2 Wire Control:

In Power-To-Lock (Fail Safe) configuration, it is possible to operate the V-Lock using 2 control wires only. With 2 wire control, the lock relies on the Fail Safe spring mechanism to unlock, which reduces the lock's capability to open under side load to only 3kg. Hence, 2 wire control is **NOT RECOMMENDED** and should be avoided wherever possible. For retrofit applications where only 2 control wires may exist, connect the BLUE and RED wires on the lock together and join them to the positive supply voltage. Connect the negative supply voltage to the BLACK wire on the lock

**Voltage:** 12 to 24VDC  
**Voltage Tolerance:** 12V (+15% - 0%) 24V(+/- 15%)  
**Current:** Minimum 1 Amp Regulated Supply  
 PTL Holding current 130mA  
 PTO Holding current 30mA

## 4 DOOR PREPARATION AND INSTALLATION OF STRIKE PLATE

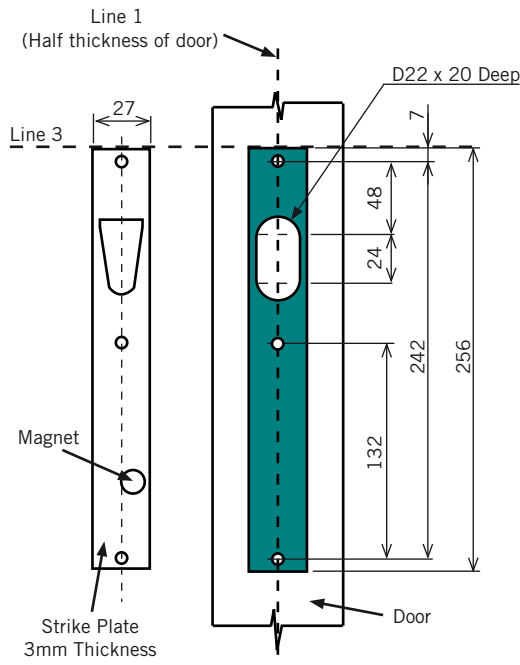

- On the door, mark Line 3 corresponding to the top edge of the lock faceplate (step3)
- Mark and recess cutout of strike plate on door symmetrically, using Line 1 as the centre guide and Line 3 as the height guide
- Cut out the 22mm wide and 20mm deep cavity for the bolt as shown above.
- Install the strike plate on the door, ensure the door gap is not more than 8mm between the strike plate and the faceplate on the V-Lock
- Ensure strike plate is securely fastened to increase overall holding force and security of installation.

**Note:** Thickness of strike plate - 3mm

## 5 INSTALLING VLOCK IN DOOR JAMB

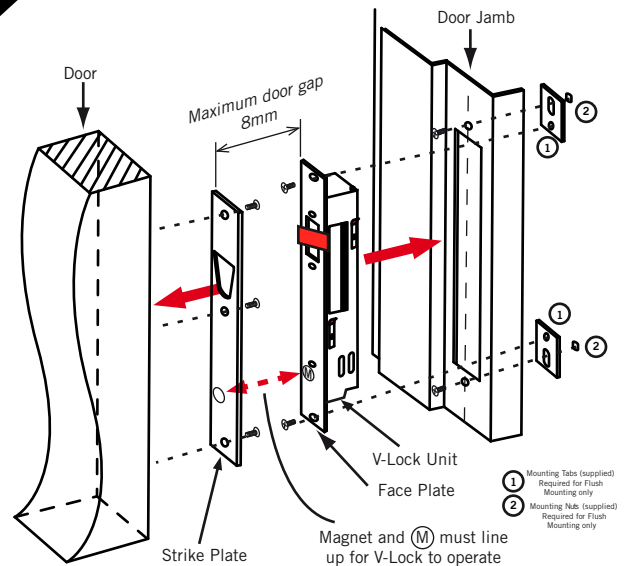

- Ensure all wiring connections are correct and are insulated, make sure the wires do not rub on the any sharp edges or do not interfere with any of the locking mechanism.
- Install the V-Lock into the door jamb as shown above
- Power up lock, then let the door open and close normally with door closer. When the strike plate magnet comes within locking range, the V-Lock will lock as long as the lock bolt closes within target locking range (see Detail A)

## 5 Year Limited Warranty

ASSA ABLOY Australia guarantees the product for a period of 5 years in accordance with the standard TRICARE warranty against defects in manufacture, workmanship or materials, provided that all electrical and mechanical installation requirements are adhered to as per this datasheet. All third party and consequential claims are expressly excluded from the warranty.



WARRANTY  
TRICARE



### ACCESSORIES AVAILABLE:

- ES8000 Glass Door Kit
- Strike plate with magnet
- Mounting bracket for high security applications