

# PP8FR

## Power Distribution Module

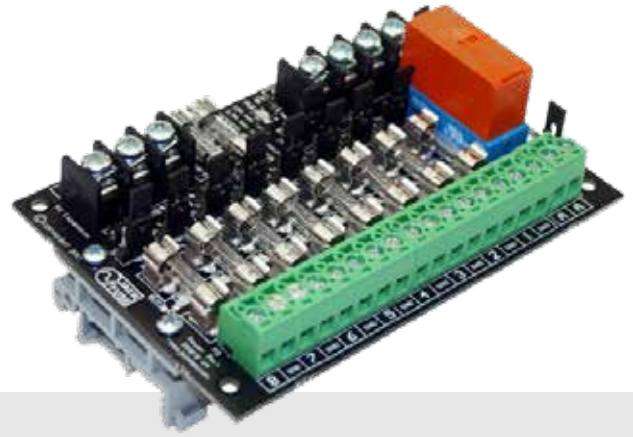

### FEATURES

- Eight individually fused outputs each with status LED
- Individually field selectable power outputs – fire power or standard power.
- On board spare fuse holders
- DIN rail mounting
- Wide range of operation voltages
- Unlimited local and remote expansion options
- N/C output for failsafe fire trip connection to extra modules or other equipment
- Drive fire relay directly from FIP voltage or onboard voltage via N/C FIP contact
- Unfused auxiliary output for expansion (see module PP10HD)
- Reduced material list, cost and install time compared to traditional methods

### APPLICATIONS

- Power distribution for electronic access control and security devices
- Fused over-current protection
- Automatic fire alarm emergency release of electric door locks
- Fire trip monitoring

### BENEFITS

The PP8FR reduces install time for technicians and helps ensure security system reliability by replacing the normally complex wiring task of fire trips with a simple, easy to fault find, all in one solution featuring built in fuses to further protect expensive installations.

### TECHNICAL DATA

|                                 |                               |                             |                          |
|---------------------------------|-------------------------------|-----------------------------|--------------------------|
| Input voltage range             | 0-26V DC                      | Fuse Type                   | 1A Normal Blow M205      |
| Fire relay coil voltage         | 12-26V DC (or dry contact)    | On board spare fuse holders | 2                        |
| Max. standard power current     | 8A                            | Mounting                    | DIN rail                 |
| Max. fire power current         | 8A*                           | Dimensions                  | 110 L X 75 W X 50 H (mm) |
| Max constant current per output | 2A (with 2A replacement fuse) | Country of Origin           | Australia                |
| Fused outputs                   | 8                             |                             |                          |

\*Peak current only – resistive load. A 20% load current margin is recommended for fire power current (6.4A). Many devices including electric locks have a higher current on start-up and at other times; this must be accounted for in the peak current. Current ratings are valid for operating temperatures up to 24 degrees C with a fire trip of 12VDC. Factors such as lock types, external heat and higher fire trip voltages must be considered when designing power loads.

### CONNECTIONS

| Terminal     | Description               | Max Conductor Size  |
|--------------|---------------------------|---------------------|
| P1 – FT- FT+ | Fire panel trip interface | 2mm <sup>2</sup>    |
| P1 – GND & + | DC Power supply input     | 2mm <sup>2</sup>    |
| P2           | Expansion Output          | 2mm <sup>2</sup>    |
| P3 1 - 8     | Fused outputs             | 1.5mm <sup>2</sup>  |
| P3 A-A       | Monitoring/output         | 1.5mm <sup>2</sup>  |
| PR           | EOL Resistor Sockets      | ¼ - ½ Resistors X 2 |

### FUNCTION

**Power Input.** The PP8FR module is powered by any suitable DC supply connected to the clearly marked input barrier terminals. A green power LED indicates power is available.

**Fused Outputs.** The eight power outputs are each individually protected by a glass fuse that will activate when a current greater than the fuse rating is drawn via the output.

The eight outputs can be fed either directly from the power input or indirectly via the fire trip relay (for ‘fire power’). This function is set via a link for each output and can be changed at any time to suit requirements.

Each output has an individual status LED. The LED will be active when ever power is available at the output. The LED will deactivate in the event of a blown fuse or if that output is set to fire power and the fire relay has tripped. Each status LED is located directly under the appropriate glass fuse to greatly aid visual confirmation of fuse status.

**Fire Trip Relay.** The fire trip relay may connect to the fire indication panel in two modes. It can be activated by 12 or 24VDC from the fire panel or via a voltage free N/C contact at the fire panel or other device. The operation mode and voltage used is set by on-board links.

When the relay is active, power will be available via the primary relay contact. This power is the input power switched via the relay and is commonly known as fire power. This power can then be used at each output. If the relay de-activates due to a fire alarm, then the fire power will no longer be available.

**Fire Trip Monitoring.** A secondary contact of the fire relay is used for monitoring. The status of the fire trip relay can be indicated to any security panel via an output. Suitable End of Line (EOL) resistors can be fitted to onboard sockets, so no soldering is required. Alternatively, a link setting will allow the output to convert to a normally closed voltage-free contact for connection to another PP8FR module or other equipment. (See Expansion)

An LED provides visual indication of the fire relay status and will be active when the fire relay is active.

### EXPANSION

Output terminals are provided for connection to expansion module PP10HD or to other equipment. The expansion output provides supply power, fire power and a common ground. Several additional PP10HD modules can be fitted at any time if current limits of the fire relay, modules and power supply are not exceeded.

Additionally, the N/C relay status output can be used to operate an additional PP8FR either in a local panel or remotely. In this way modules can be added to suit any size access control/security system.

### Expansion Example

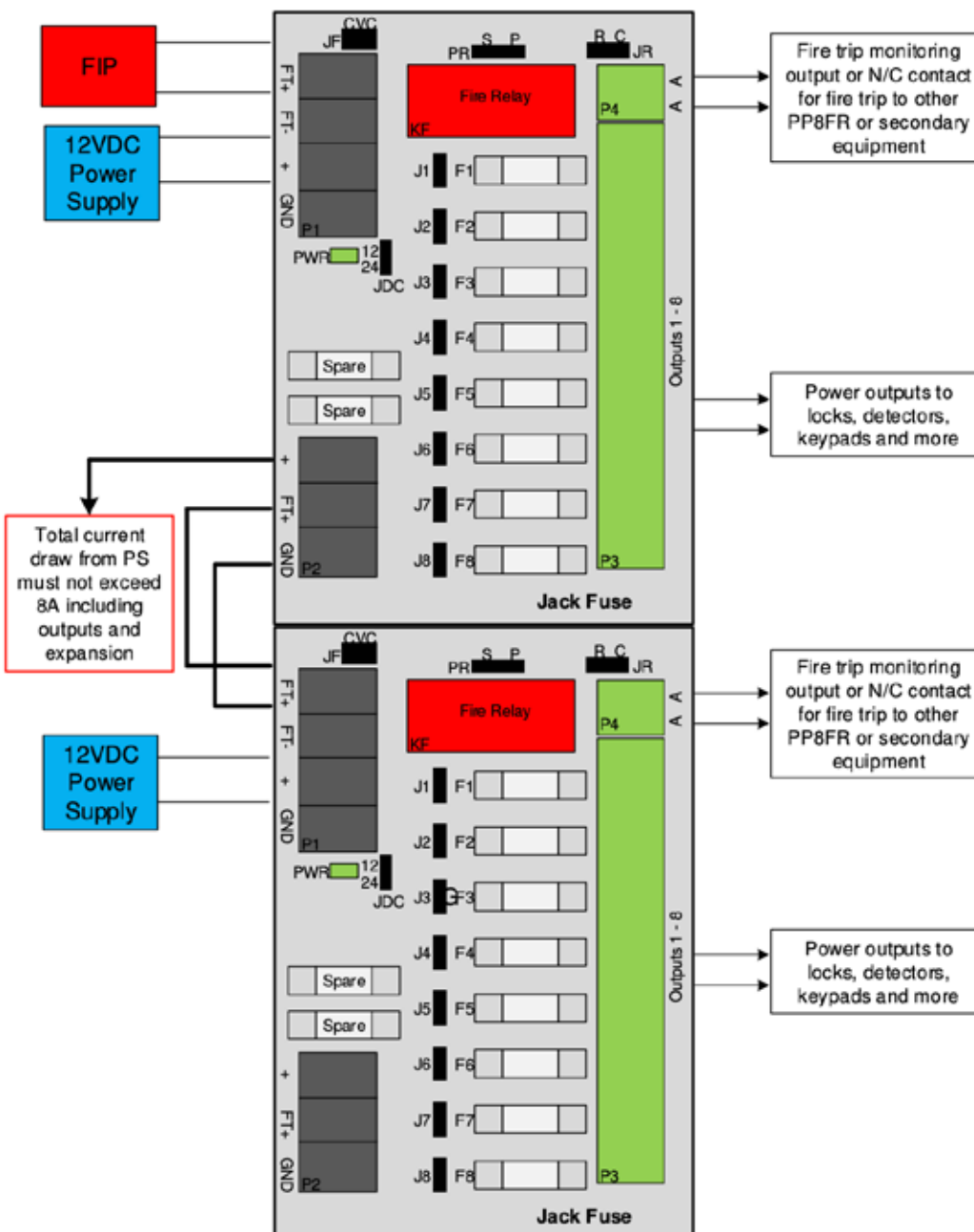

### MOUNTING

The PP8FR module is supplied pre-fitted with cost effective DIN rail mount clips suitable for most DIN rail profiles.

The PP8FR is also suitable for use with popular “Snap Track” made by TE Connectivity, part number 4TK2.

### ORDERING CODE

|        |   |
|--------|---|
| PP8FR  | Power Port 8FR supplied with a din rail mount kit, fire relay and 8 X 1A glass fuses. |
| PP10MG | Power Port 10MG supplied with a din rail mount kit and 10 X 1A glass fuses            |
| PP8PTC | Power Port 8PTC supplied with a din rail mount kit, fire relay and 8 X PPTC fuses.    |
| PP10HD | Power Port 10HD supplied with a din rail mount kit and 10 X 1A PPTC fuses             |

### LEARNING

Become a Jack Fuse Product and Power Certified Technician. Free training available online.  
More Information: For complete installation notes, data sheets and technical support please visit [www.jackfuse.com](http://www.jackfuse.com).