

## Indicator Post Wall Type



### Technical Features

- Wall Type
- Approvals: UL, ULC, FM
- Corrosion Protection - Internal & External Epoxy Coated (RAL 3000)
- Weight(lbs): 99.2



Parts	Components	Material	Specification
1	Eyebolt	Carbon Steel	ASTM A307B
2	Hex Nut	Carbon Steel	ASTM A307B
3	Washer	Carbon Steel	ASTM A570Gr.33
4	Handwheel	Ductile Iron	ASTM A536 Gr.65-45-12
5	Hex Cap Screw	Carbon Steel	ASTM A307B
6	Square Nut	Carbon Steel	ASTM A307B
7	Snap Ring	Stainless Steel	ASTM A307B
8	Cover	Cast Iron	ASTM A126ClassB
9	Operating Nut	Bronze	ASTM B62C83600
		Stainless Steel	AISI 304
10	Target Carrier Nut	Bronze	ASTM B62C83600
		Stainless Steel	AISI 304
11	Window Glass	Plexiglass	Plexiglass
12	Gasket	PTFE	PTFE
13	Hex Nut	Carbon Steel	ASTM A307B
14	Plug	Malleable Iron	Malleable Iron
15	Target	Cast Aluminium	Cast Aluminium
16	HexCap Screw	Carbon Steel	ASTM A307B
17	HexNut	Carbon Steel	ASTM A307B
18	Body	Cast Iron	ASTM A126ClassB
19	Stem	Carbon Steel	AISI 1045
20	Crane Coupling	Ductile Iron	ASTM A536Gr.65-45-12
21	Cotter Pin	Stainless Steel	AISI 304

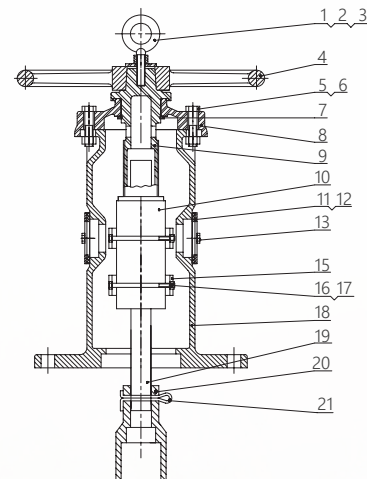

### Field Adjustment

1. Remove the top section from the top of the indicator Post assembly
2. Set the "Open" and "Shut" targets for the appropriate valve size.
3. Reattach the top section to the top of the indicator post assembly.
4. Design and dimensions are subject to change without notice.

