

ALAPC Angle Pad Coupling

- **Model** | ALAPC
- **Size** | 1" thru 12"
- **Approvals** | UL, ULC, FM
- **Working Pressure**
 - UL, ULC, FM | 300 PSI / 2.07 Mpa
 - Mechanical | 500 PSI / 3.45 Mpa
- **Housing** | Ductile Iron ASTM A536 Gr. 65-45-12
- **Gasket** | Prelubricated EPDM - ANSI / NSF 61
- **Bolt / Nut** | Carbon Steel heat treated & zinc electroplated, ASTM A183 Gr. 2; Hex Nuts ASTM A563, Gr. B
- **Paint Color** | Orange Enamel, Optional : Red

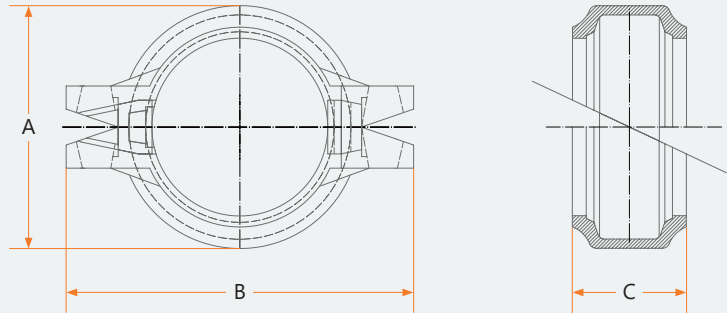

Angle Pad Coupling

Nominal Size		Pipe OD.		Dimensions						Bolt		Axial Displacement	
in	mm	in	mm	A		B		C		Inches	mm	Inches	mm
				in	mm	in	mm	in	mm				
1	25	1.327	33.7	2.28	58	3.85	98	1.77	45	3/8x1 3/4	10x45	0~0.06	0~1.6
1 1/4	32	1.669	42.4	2.68	68	4.17	106	1.77	45	3/8x1 3/4	10x45	0~0.06	0~1.6
1 1/2	40	1.9	48.3	2.91	74	4.49	114	1.77	45	3/8x1 3/4	10x45	0~0.06	0~1.6
2	50	2.375	60.3	3.39	86	5.04	128	1.77	45	3/8x2 1/4	10x55	0~0.06	0~1.6
2 1/2	65	2.875	73	3.86	98	5.39	137	1.77	45	3/8x2 1/4	10x55	0~0.06	0~1.6
2 1/2	65	3	76.1	4.06	103	5.55	141	1.77	45	3/8x2 1/4	10x55	0~0.06	0~1.6
3	80	3.5	88.9	4.57	116	6.22	158	1.77	45	3/8x2 1/4	10x55	0~0.06	0~1.6
4	100	4.5	114.3	5.55	141	7.56	192	1.96	50	1/2x2 1/2	12x65	0~0.13	0~3.2
5	125	5.563	141.3	6.81	173	8.86	225	1.96	50	1/2x3.0	12x75	0~0.13	0~3.2
6	150	6.5	165.1	7.83	199	9.92	252	1.96	50	1/2x3.0	12x75	0~0.13	0~3.2
6	150	6.625	168.3	7.95	202	9.92	252	1.96	50	1/2x3.0	12x75	0~0.13	0~3.2
8	200	8.625	219.1	10.16	258	12.67	322	2.28	58	5/8x3 3/4	16x95	0~0.13	0~3.2
10	250	10.75	273	12.51	318	15.43	392	2.28	58	3/4x4 1/4	20x110	0~0.13	0~3.2
12	300	12.539	323.9	14.53	369	17.72	450	2.28	58	3/4x4 1/4	20x110	0~0.13	0~3.2