



## Indicator Post Vertical Type

### Technical Features

- Vertical Type, Adjustable
- Approvals: UL, ULC, FM
- Corrosion Protection - Internal & External Epoxy Coated (RAL 3000)
- Weight(lbs): 211.6



Parts	Components	Material	Specification
1	Hex Cap Screw	Carbon Steel	ASTM A307B
2	Hex Nut	Carbon Steel	ASTM A307B
3	Crane Coupling	Ductile Iron	ASTM A536 Gr.65-45-12
4	Cotter Pin	Stainless Steel	ANSI 304
5	Base Flange	Cast Iron	ASTM A126 ClassB
6	Hex Nut	Carbon Steel	ASTM A307B
7	Hex Cap Screw	Carbon Steel	ASTM A307B
8	Standpipe	Carbon Steel	ASTM A536 Gr.65-45-12
9	Stem 1" Square	Carbon Steel	AISI 1045
10	Body	Cast Iron	ASTM A126ClassB
11	LockingWrench	Ductile Iron	ASTM A53 6Gr.65-45-12
12	Target Carrier Nut	Bronze	ASTM B62C83600
		Stainless Steel	ANSI 304
13	Hex Cap Screw	Carbon Steel	ASTM A307B
14	Hex Nut	Carbon Steel	ASTM A307B
15	Hex Cap Screw	Carbon Steel	ASTM A307B
16	Target	Cast Aluminium	Cast Aluminium
17	Window Glass	Plexiglass	Plexiglass
18	Gasket	PTFE	PTFE
19	Operating Nut	Bronze	ASTM B62C83600
		Stainless Steel	ANSI 304
20	Top Section	Cast Iron	ASTM A126ClassB
21	Snap Ring	Stainless Steel	AISI 1066
22	Plug	Malleable Iron	Malleable Iron
23	Square Nut	Carbon Steel	ASTM A307B
24	HexCap Screw	Carbon Steel	ASTM A307B

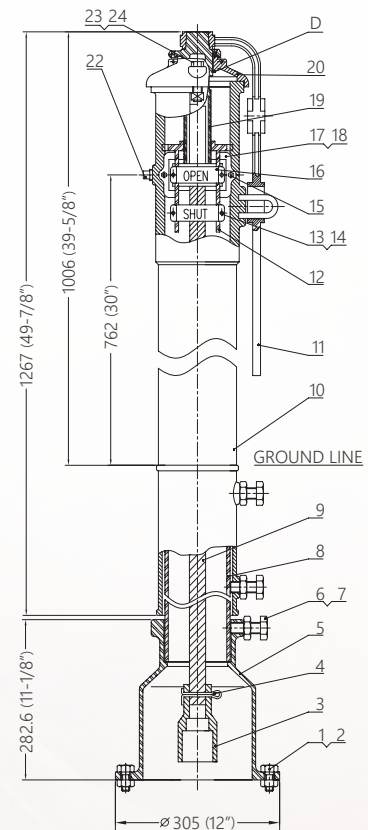

### Field Adjustment

1. Remove the top section from the top of the Indicator Post assembly.
2. Cut the required length off the bottom of the Standpipe for the Ground Line to match up with Standpipe Ground Line mark.
3. Set the "Open" and "Shut" targets for the appropriate valve size.
4. Reattach the top section to the top of the Indicator Post assembly.
5. Design and dimensions are subject to change without notice.

\* The adjustable dimension is 34.5" to suit deeper buried valves.