

# FIRELET<sup>®</sup>

## FOR FIRE SPRINKLER PIPE FABRICATION

Firelet<sup>®</sup> Female Threaded Welding Outlet  
Size-on-Size, for Automatic welding machines

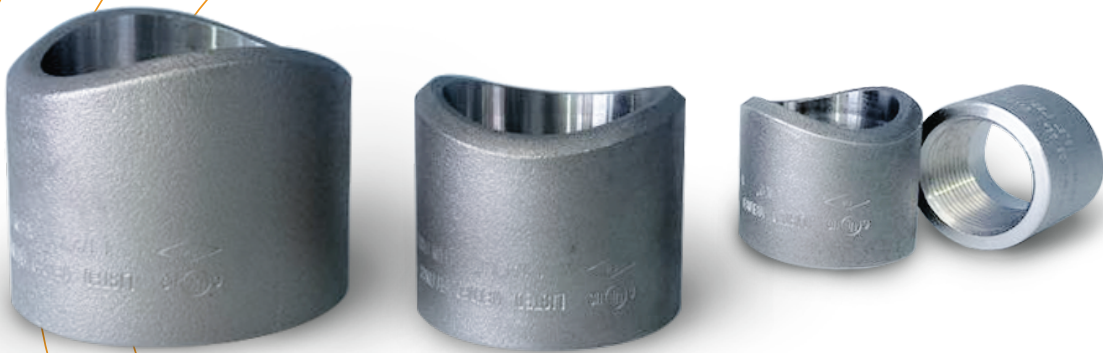
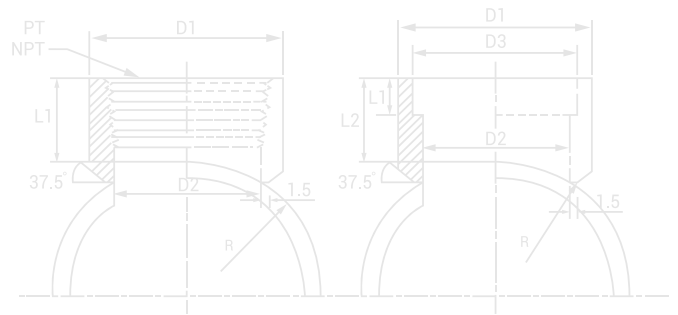

# FIRELET® Female Threaded Outlet

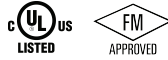

- ✓ Hole Size : Full inside diameter of outlet
- ✓ ANSI B1.20.1 NPT Threads
- ✓ Application Pipe Type : ASTM A53 / A135 / A795
- ✓ Manufactured from carbon steel conforming to ASTM 1010, Gr. A53, A135 or A795
- ✓ Oil-free
- ✓ C.O.O. S. Korea

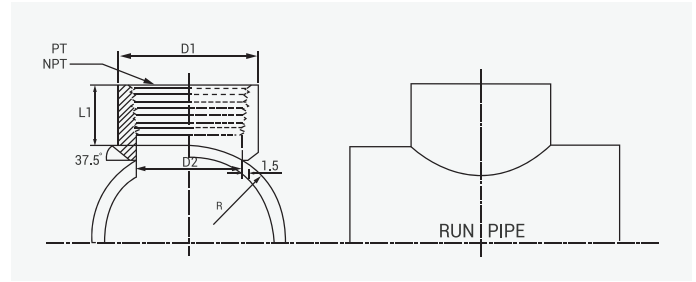

Dimensions									
Nominal Outlet		Nominal Header		Socket Length (L1)		Outside Diameter (D1)		Inside Diameter (D3)	
Inch	mm	Inch	mm	Inch	mm	Inch	mm	Inch	mm
1/2"	15	1"	25	0.377"	9.6	1.039"	26.4	1.039"	26.4
		1-1/4"	32						
		1-1/2"	40						
		2"	50						
		2-1/2"	65						
		3"	80						
		4"	100						
		5"	125						
3/4"	20	1"	25	0.5"	12.7	1.251"	31.8	1.251"	31.8
		1-1/4"	32						
		1-1/2"	40						
		2"	50						
		2-1/2"	65						
		3"	80						
		4"	100						
		5"	125						
1"	25	1-1/4"	32	0.5"	12.7	1.555"	39.5	1.555"	39.5
		1-1/2"	40						
		2"	50						
		2-1/2"	65						
		3"	80						
		4"	100						
		5"	125						
		6"	150						
8"	200								
1-1/4"	32	2"	50	0.5"	12.7	1.90"	48.3	1.90"	48.3
		2-1/2"	65						
		3"	80						
		4"	100						
		5"	125						
1-1/2"	40	2"	50	0.5"	12.7	2.145"	54.5	2.145"	54.5
		2-1/2"	65						
		3"	80						
		4"	100						
		5"	120						
2"	50	2-1/2"	65	0.625"	15.9	2.61"	66.3	2.61"	66.3
		3"	80						
		4"	100						
		5"	120						
		6"	150						
2-1/2"	65	3"	80	0.625"	15.9	3.228"	82	3.228"	82
		4"	100						
		5"	125						
		6"	150						
		8"	200						