

# RANDRIDE

## RANDRIDE E-bike User Operation Manual Hand Control Panel Operation Instruction



### ONE. The apparent size and material

The shell of the product is ABS, and the liquid crystal transparent window is imported acrylic with high hardness, whose hardness is equivalent to the tempered glass.

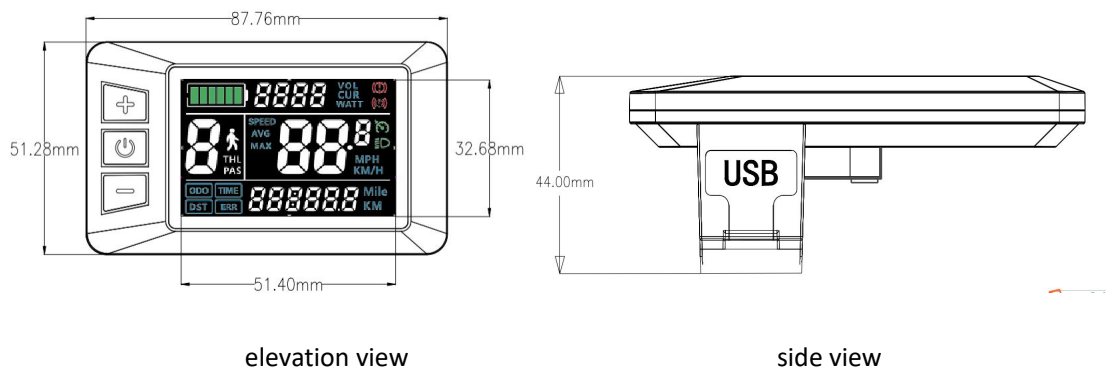

### TWO. Working voltage and connection mode

(1) working voltage: DC24V, 36V, 48V, 60V compatibility (instrument selection setting), Other voltages can be customized.

(2) connection mode:

Line sequence of the label connector

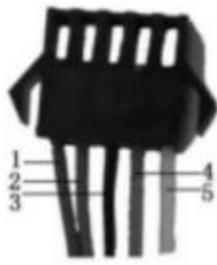

Connected to the controller



Meter outlet end



To the terminal

**Note:**The lead wire of some products uses the waterproof connector, and the user cannot see the lead color in the wire harness

### 三、Function description:

#### 1.display function

Speed display, power indicator, fault indication, total mileage, single mileage

#### 2.Control, setting up functions

Power switch control, wheel diameter setting, idle automatic hibernation time setting, backlight brightness setting,

Start mode setting, drive mode setting, voltage level setting, controller limit value setting,

#### 3.Communication protocol:UART

All contents of the display screen (full display in boot 1S)

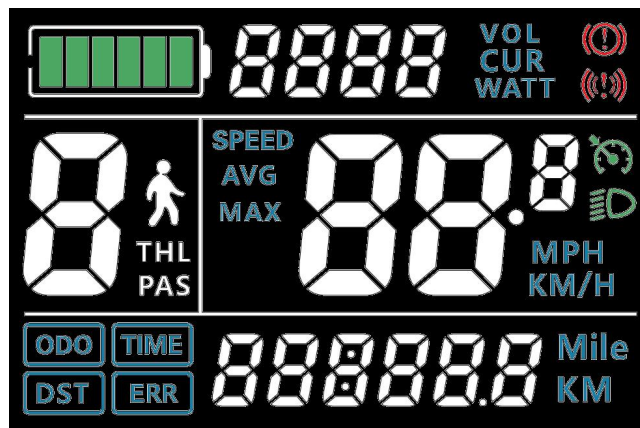

Show content introduction

#### 3.1 Battery power display

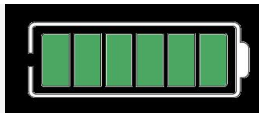

#### 3.2 Multifunctional display area



Total mileage ODO, single mileage TRIP(unit: mile, km), single boot time TIME, Error Code;

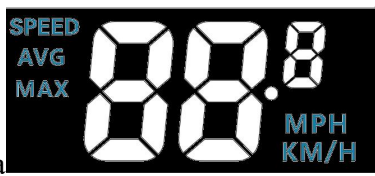

### 3.3 Speed display area

AVG: average speed, MAX: max speed, SPEED: current speed; 单位 Mp/h, km/h

The speed signal is taken from the Hall signal in the motor and sent to the instrument by the controller.(The time of a single Hall period, unit: 1MS) The instrument will calculate the true speed based on the diameter of the wheel and the signal data(the number of magnetic steel needed by the motor Hall)

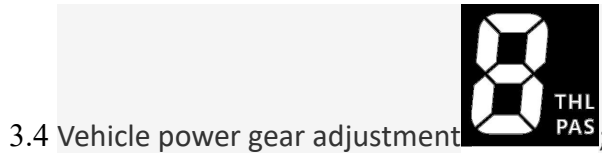

### 3.4 Vehicle power gear adjustment

### 3.5 Vehicle status icon display :



Condition code meaning of number 2 vehicle:

Status code(Decimal system)	Condition meaning	Remark
E02	Brake	
E06	Battery under voltage	
E07	Electrical machinery problem	
E08	handle problem	
E09	Controller problem	
E10	Communication reception problem	
E11	Communication send problem	

## 4. Setting

**P01:** Backlight brightness, level 1 darkest, level 3 brightest;

**P02:** mileage unit, 0: KM; 1: MILE;

**P03:** Voltage level: 24V, 36V, 48V, 60V, 64V default 36V;

**P04:** Dormancy time: 0, not dormancy; Other numbers are dormancy times, range: 1-60; Unit minutes;

**P05:** Help file bit: 0, 3 file mode:

1,5 gear mode:

**P06:** Wheel diameter: unit, inch; Precision: 0.1;

This parameter is related to the meter display speed and needs to be entered correctly;

**P07:** Speed gauge magnetic steel number: range: 1-100;

This parameter is related to the meter display speed and needs to be entered

correctly;

If it is an ordinary hub motor, direct input of magnetic steel;

If it is a high-speed motor, it is also necessary to calculate the deceleration ratio, and

the input data = the number of magnetic steel × deceleration ratio;

For example: number of motor magnets 20, deceleration ratio 4.3: input data is:  $86 =$

$20 \times 4.3$

**P08:** Speed limit: range 0-100km / H, 100 means no speed limit,

The input data here represents the maximum operating speed of the vehicle: for example, input 25, indicating that the maximum operating speed of the vehicle will not exceed 25km/h; Drive speed maintained at set value,

Error:  $\pm 1$ km/h; (Speed limit for power and steering)

Note: The value here is based on kilometers. When the unit setting is converted from kilometers to miles, the speed value of the display interface automatically converts to the correct mile value, but the speed limit value set at this menu under the mile interface is not converted. Is inconsistent with the actual speed limit of the mile speed;

Note: P09-P15 menu is only valid in communication state

**P09:** zero start, non-zero start setting, 0: zero start; 1: Non-zero start;

**P10:** The drive mode is set to 0: Power Drive(how much power is output is determined by the power file bit, and the switch is invalid).

1: Electric drive(by turning the handle drive, when the power file bit is invalid).

2: Power Drive and Electric Drive Coexistence

**P11:** Help sensitivity setting range: 1-24;

**P12:** Help start intensity setting range: 0-5;

**P13:** Power Magnetic Steel Disk Type Setting 5, 8, 12 Magnetic Steel Types

**P14:** Controller limit value set default 12A range: 1-20A

**P15:** Controller undervoltage

**P16:** ODO zero setting length press key 5 seconds ODO zero

**P17 :**0: No enabling cruising, 1: enabling cruising; Automatic cruise optional(valid for protocol 2 only)

**P18:** Display speed ratio adjustment range: 50 % ~ 150 %,

**P19:** 0 power bit, 0: 0, 1: does not include 0



**P20 :**0:2 Protocol 1:5 S Protocol 2: Standby 3: Standby

#### 四、Key Introduction:

1、 Press and hold the  button to start the display when the display is off. After



power-on, press  button to switch between ODO, DST and TIME.







2、 Press and hold the  button to shut down the display when the display is on.

Press  button, PAS+1.Press  button, PAS-1.

3、 Press and hold  button to turn on/off the headlight under the normal display speed interface.

4、 Under the interface of normal speed display, when the vehicle is stationary, press and hold  button will enter 6KM/h in walk mode, and then let go and exit.

3、 Press and hold  button and  button enter Settings

Parameter value modification: under a parameter state , press  button switch Parameters , press  button value plus one , press  button value minus one. And when it's modified , press  button switch to the next parameter and save the previous parameter value; Press and hold  button and  button again to save and exit the settings. If not, wait 8 seconds to automatically exit and save the parameters.

**Note: due to the upgrade of the company's products, the content of the product will be different from the specifications, but it will not affect your normal use.**

## RANDRIDE Bikes

**Address:** NO. 68 HOI YUEN ROAD, KWUN TONG, KOWLOON, HONGKONG

**Email:** support@randridebikes.com / randridebikes@gmail.com

**Contact Number:** 0519-69656597

**Web:** www.randridebikes.com