

**ansuz**<sup>o</sup>  
ACOUSTICS

THE POWER OF PASSION



# TABLE OF CONTENTS

## NEW D-TC SUPREME

Cables, Powerbox and Power Distributor



PAGE 4 - 7

## WHO IS ANSUZ

The people and the passion



PAGE 14 -15

## D2, C2, A2, P2

Cables, and Power Distributors



PAGE 16 - 25

## X

Cables, and Power Distributors



PAGE 26 - 29

## STREAMING

Cables and Power Switch



PAGE 30 - 31

## DARKZ

Resonance controls and how to use them for mechanical grounding

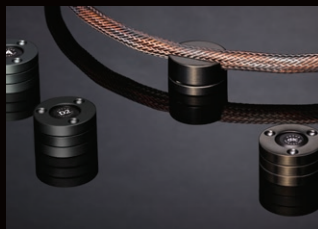

PAGE 32 - 35

## SPARKZ

The magic of silence



PAGE 38 - 39

## HOW TO

Setup and Grounding basics

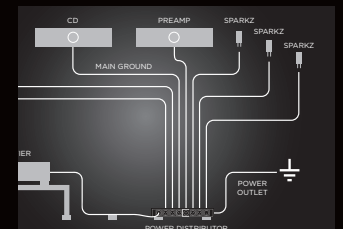

PAGE 42 - 45

## SMALL CHANGES - HUGE IMPROVEMENTS



If you have already entered the Anszu universe, you know how important proper cabling and resonance control are to the musical performance of your High End system. If the first encounter with Anszu still lays ahead - great experiences await you. You are about to be thrilled with the potential of performance the Anszu products can reveal in your music system.

As Anszu cables and accessories can only be experienced to the fullest with all your senses, this brochure can only give you an overview of the different products. We invite you to hear, see and feel the Anszu products in real life - please book a demonstration in a showroom near you.



## ANSUZ D·TC SUPREME | SECOND TO NONE



Striving to create perfection, Anszuz constantly develop and test new ideas, and sometimes these ideas prove to be right. The latest, and so far our most ultimate concept, the Anszuz D·TC SUPREME series has elevated reproduction of musical micro details to a much higher level. The cables of the D·TC SUPREME series is almost “invisible”, reducing inductance and capacity to an unprecedented low level. Anszuz Technologies has been applied to an extent that exceeds anything we have previously produced.

## CLOSER TO PERFECTION



The beautiful 3D housing, with genuine leather inserts holds massive amounts of Anszu Technologies, carefully applied to achieve the exact reproduction we like, practically eliminating the cables impact to the musical experience

To eliminate risk of unwanted resonances, the exclusive aluminium housing is treated in a hitec process adding the acoustically optimized layers of Zirconium and Tungsten. Finally a hard layer of aluminum titanium nitride is applied to obtain the desired surface properties and a beautiful visual appearance.



## ANSUZ D·TC SUPREME

The exclusive aluminium housing is treated in a hitec process adding the acoustically optimized layers of Zirconium and Tungsten. Finally a hard layer of aluminum titanium nitride is applied to obtain the desired surface properties and a beautiful visual appearance.

In the cable itself, the massive conductors are individually shielded to reduce the risk of dither to an absolute minimum.

# GROUNDBREAKING TECHNOLOGIES



The Ansz D-TC Cables have an amazing ability to let you experience natural micro details in your recordings, which you have not previously heard.

The D-TC Cable series has a beautiful and aesthetic design with selective laser engraved D-TC housings that integrate beautifully into your Audio System.

Generally speaking, Ansz is not just about exotic materials and fancy terms. It is much more about a deeper understanding about how to transfer signals, voltage and current through a cable with the least possible influence. That is also the reason why we focus on bringing down the values of inductance and capacity to unheard of levels.









d·t·c

Power Cord | Speaker wire | Interconnects | Digital interconnect | USB interconnect | Phono cable | Jumpers set | Powerbox | Power Distributor | Darkz

# NEW DESIGNED POWERBOX FOR POWERFUL INTERCONNECTS

The Ansz D-TC Powerbox is designed to be the necessary low voltage power supply for all D-TC and D-TC SUPREME Interconnects, and a big upgrade for the mains system, as it also adds a lot of Ansz NSC® and ATC® technology to the 110/230V power-system. Even without any need for the low voltage, the Powerbox will be a great upgrade for any Audio/video system.



The Ansz Powerbox provide individual power for up to 14 D-TC SUPREME/D-TC/D-2 cables separated in line/digital and phono. Beside feeding the cables in your setup, the powerbox will provide 14V DC current to those of your units that will benefit from this very special powersupply.

The Ansz Powerbox is even more versatile than it's predecessor. Beside giving the design a remarkable facelift, the physics and dimensions of the box has been vastly improved, making room for even more of our signature technology.

The Ansz Powerbox comes in three quality levels:

- ⊙ D-TC SUPREME
- ⊙ D2
- ⊙ X-TC

*Using the D-TC SUPREME and D-TC interconnects requires this special D-TC SUPREME, D2 or X-TC Powerbox which is sold separately. For the D-2 series interconnects & speaker wires it is not mandatory to use the Powerbox, although it is a big upgrade possibility*

*All Ansz D-TC SUPREME, D-TC & D-2 interconnects come with low voltage power cords.*

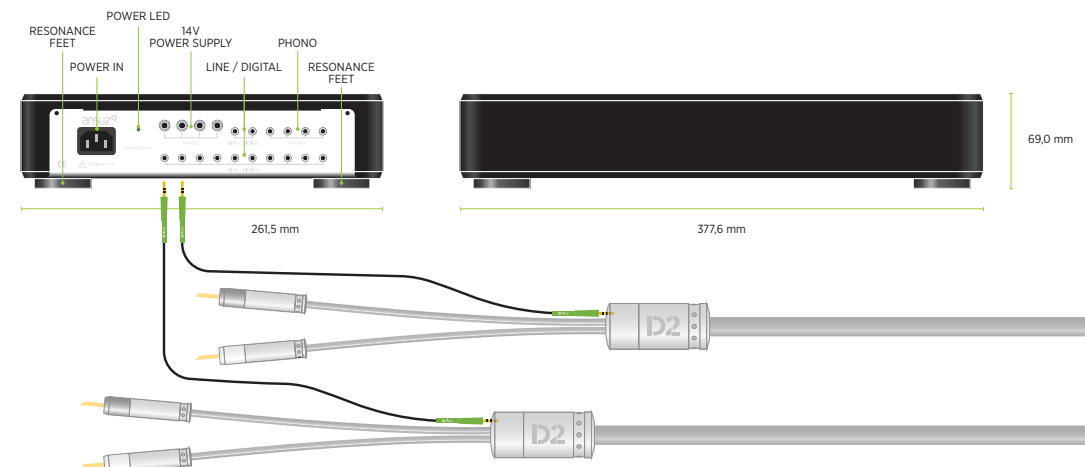

## ANSUZ MAINZ8 D-TC | THE HEART OF YOUR MUSIC SYSTEM



The Mainz8 D-TC features star grounding and the unique Sparkz and NSC technologies.

Ansz Mainz8 D-TC Power Distributor is a mains and ground distribution unit. It has 8 dedicated mains outlets and features an extremely low impedance star grounding system.

When using the Mainz8 D-TC, try to connect the main ground to your pre- or integrated amplifier where your sources are connected. Doing this will minimize the ground potential between your devices and thus minimize ground current and signal induced fluctuations.







## THE PEOPLE BEHIND THE PASSION

A few years ago, Lars Kristensen and Michael Børresen established Ansuz Acoustics together with two more partners. Built around their vast experience and know-how from the High-End field, the company has grown fast, and very quickly Ansuz Acoustics could introduce a range of Resonance controls and High-End Cables to the market. At that time, the vision was to complement the integration between the music system's different electronics and loudspeakers with accessories that would allow the music system to play without any impact from wiring and environment – though we are not there yet, we have come a very long way in accomplishing our vision.

With a focus on mains supply and working to improve the values of capacitance and inductance, the performance of the first Ansuz products impressed customers worldwide.

“Developing the Ansuz Cables and Accessories is based on researching and developing new technologies. This process entails days and months of testing, of trial and error to identify how we can best combine and further advance so far well-known scientifically documented principles. With this approach, we are creating the unique sound quality and outstanding musical feeling, we like our customers to experience.

Many years of experience make us qualified to successfully push existing limits of technology even further, selecting the materials, adding the finishes and creating them in the shape and dimensions we think will give us the result we strive for. And if an idea does not prove right, we trash it, rethink and start again, trying to utilize what we have learned in a new approach.

We believe that this is the way great results and innovative ideas have been created through time.

Although Ansuz Acoustics is led and run by Lars and Michael, a major part of the success comes from our professional and skilled workforce. Located in Denmark, we utilise the innovative and aesthetic mindset that has always been a part of the Danish culture.

**ansuz**   
ACOUSTICS



# ANSUZ D2 | A GIANT LEAP FOR PERFORMANCE



*Using the D-TC interconnects requires the special D-TC Powerbox (sold separately)  
For the D-2 series interconnects & speaker wires it is not mandatory to use the Powerbox,  
although it is a big upgrade possibility.*

*All D-2 interconnects come with low voltage power cords.*

The Ansz D2 cables have been created using all the know-how gathered from many years of developing High-End products.

We continue to utilize the Ansz technologies DGC (Direct Ground Connector Technology), DIHC (Double Inverted Helix Coil technology) and NSC (Noise Suppressing Coil technology) - and on top of that, we have added further ground-breaking technologies such as dynamically charged Dielectricum and the active Tesla Coil in this unique cable concept.

Years of working with High-End sound has taught us that superior grounding, low inductance and less stray capacitance are important in creating optimum conditions for achieving good performing connections between your audio components, and that these are still very valid focus areas. But the new D-TC line of cables has also taught us that the migration of charge in and out of the dielectricum has a huge influence on the way cables interact with the low level micro details in the music signal. When making the connection with the D2 or D-TC cables, you will be stunned with the amount of previously unheard natural micro details present in your recordings.

# D2

Power Cord | Speaker wire | Interconnects | Digital interconnect | USB interconnect | Phono cable | Jumpers set | Power box | Power Distributor | Darkz







## ANSUZ C2 | FEEL THE MAGIC



Now with AARC. Michael Børresen and Ansz development team have continued to uncover and eliminate the negative impacts of the cables to the signal. First, inductance and capacitance in the cables were reduced to unprecedented low values with DIHC (Double Inverted Helix Coil Technology). Now AARC (Anti Area Resonance Coil Technology) is introduced, which removes the cable's tendencies to resonate and receive signals/noise from the surroundings. You will find AARC in the C2 & D2 series.



Power Cord | Speaker wire | Interconnects | Digital interconnect | USB interconnect | Phono cable | Jumpers set | Power Distributor

## ANSUZ A2 | CHANGING THE GAME



Ansuz A2 series is a true “game changer”. With the A2 series, the Ansuz philosophy and the techniques really shine through. The A2 series is comparable to the best of the best cables on the market - the performance of these cables will impress you.

All A2 products are based on Ansuz unique Direct Ground Connector Technology (DGC), and Double Inverted Helix Coil Technology (DIHC).

# A2

Power Cord | Speaker wire | Interconnects | Digital interconnect | Phono cable | Jumpers set | Power Distributor



## ANSUZ MAINZ8 A2 / C2 / D2 | POWER DISTRIBUTOR



Following the launch of the successful Mainz8 D-TC power distributor, we could see the possibilities in implementing a comprehensive update on our previous models Mainz8 A/D, using some of the same technologies that form the basis of the D-TC model's formidable performance.

Ansuz Mainz8 A2/C2/D2 is designed in family with the Mainz8 D-TC, but the new models differ in the amount of technologies and of course in price. When it comes to performance, the Mainz8 A2 starts well over the old Mainz8 D, and together the biggest models C2 and D2 it will fill out the huge quality gap we have created with the Mainz8 D-TC.



## ANSUZ P2 | WELCOME TO THE ELITE



With the introduction of the 2 series, Ansz Acoustics has taken another remarkable step in the price/performance ratio. This apply to the P2 as well, because its performance is at least in line with the previous Aluminium series - so get in the absolute world elite of High-End performance without paying a fortune.



# P2

Power Cord | Speaker wire | Interconnects | Digital interconnect | Jumpers set







## ANSUZ X | A BREATH OF FRESH AIR

With the X series, Ansz Acoustics has met a great wish from music lovers and Hi-Fi enthusiasts, who have felt that an Ansz set-up was a bigger investment than they were willing to make. Even with the strong price/performance ratio of the X cables, the compromises are next to non-existent.

The Ansz X cables is made of twisted, shielded, silver-plated copper solid-cores in mechanically stable Teflon insulation.



## ANSUZ MAINZ8 X | STAR-GROUND BASICS

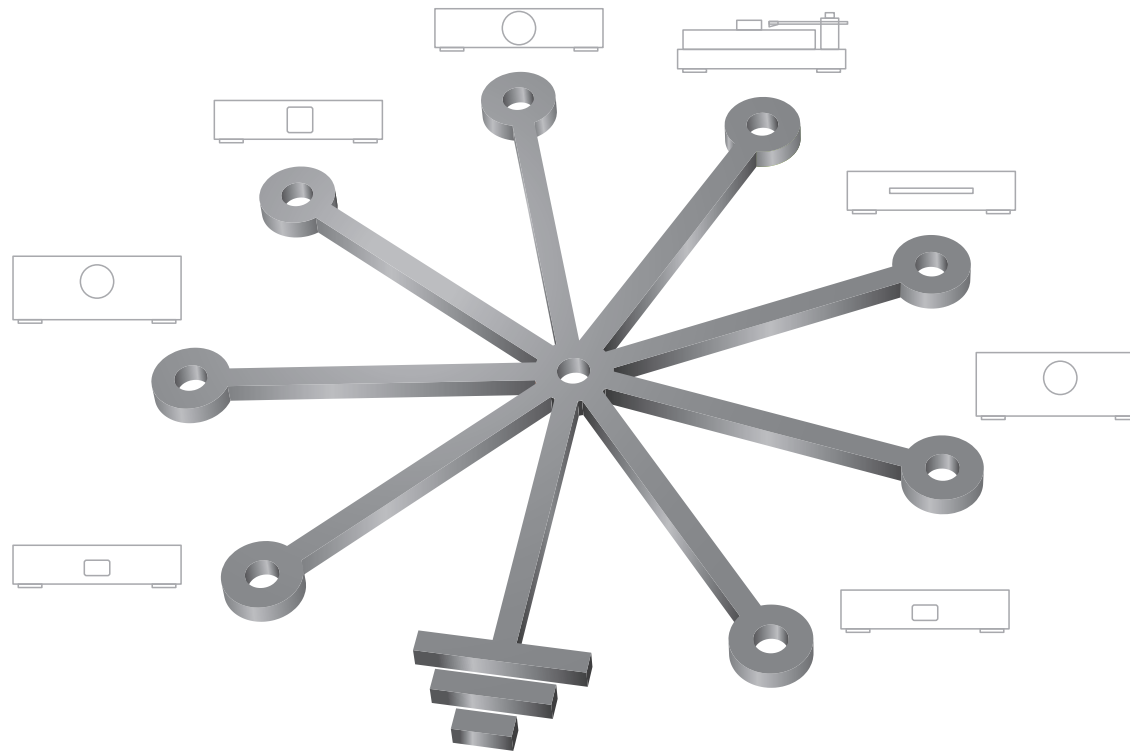

The strong heart of a system. Mainz8 X will supply a steady flow of current to even the most demanding High-End system. With its massive capacity of grounding through star grounding technology, it features the same principles as the Ansz Mainz cables line, and deliver the best possible groundwork for High-End performance.

Mainz8 X is available in 2 versions: Mainz8 X and Mainz8 X·TC, which includes technology that makes the model perform at top level.



Power Cord | Speaker wire | Interconnects | Digital interconnect | USB interconnect | Jumpers set | Power Distributor



ansuzo  
ACQUSTICS  
MAINZ 8 X - POWERDISTRIBUTOR  
MADE IN DENMARK

## ANSUZ ACOUSTICS | STREAMING



If you are an audiophile and enthusiastic lover of music who is toying with the idea of tapping into the realm of music streaming, be aware that the quality of setting up your LAN-network is just as important as setting up a high-end audio network itself.

Ansuz's philosophy has always been to use state-of-the-art and sophisticated materials in their manufacturing, and to implement only the highest standards in the quality of its products.

Ansuz cables reflect the company's unwavering devotion to opening up existing technological frontiers. So, no matter the configuration of an audio system, Ansuz power cables and interconnects will elevate the sound level of any audio system into an entirely new musical dimension. The introduction of the new Ansuz digital cables proves all of the above.

When we began creating the best LAN cables for high-end purpose, we also learned the significant role a switch plays in a high-end audio network. So, consequently, we embarked on developing what we believe to be by far the best performing audio switch available on the market.

# ANSUZ ACOUSTICS | WILL MAKE YOUR STREAMING COME TRUE

The Ansz Power Switch Box is a combination of a new upgraded version of a Power Box and a sophisticated Ethernet switch. It provides a great power supply, best grounding, efficient shielding, and a mechanical design with excellent mechanical grounding through Darkz Feet (upgradable with Darkz and titanium balls). Additionally, the Ansz Power Switch Box has an integrated Power Box to power the active Ethernet and Digital cables (D2, D-TC & D-TC Supreme).

The Power Switch Box is also equipped with Ansz's Noise Suppressing Coil Technology (NSC). This integrated NSC technology will impact any audio setup in two ways. So, when adding the Power Switch Box to a high-end music system and connecting it to the mains power distributor, it will not only enormously benefit the quality of the streaming output but also advance the audio potential of the entire music system.

The sound quality that the new Power Switch Box, in combination with Ansz Ethernet cables delivers, is typical of what all Ansz technologies stand for: A constant drive for uncompromising musicality. Streamed music that formerly sounded compressed, somehow like wrapped in a gray haze and therefore always unnatural, can now unfold its authentic sound quality with an amazing natural ease, embedded in a remarkable black and quiet background.

Ansz Power Switch Box and Ethernet cables now elevate streaming music to actually the same level as CDs !!

The Ansz Power Switch Box reflects another quantum leap in audio technology. Ansz offers a range of 4 different Power Switch Box models: X-TC, A2, D2 and D-TC SUPREME.

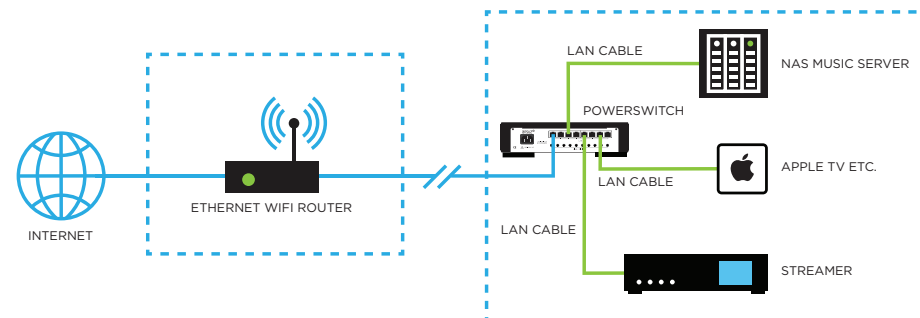



## ANSUZ DARKZ | MECHANICAL GROUNDING

Prevent Mechanical Vibrations with Anszu Darkz. Anszu Darkz is a series of efficient devices to ground all components in a high-end audio system. They are mechanically tuned to allow vibrations a path out of the component and to keep various components individually isolated. The sonic improvement caused by Anszu Darkz is undeniable and addictive.

### 1 > DARKZ

A significant upgrade from standard-mounted component feet. Darkz are available in 4 Quality levels; D-TC, D2, C and A. Darkz can be fixed under the speakers using Darkz Feet.

### 2 > DARKZ ADJUSTABLE

Height adjustable Darkz Adjustable is available in 4 quality levels; D-TC, D2, C and A. Darkz Adjustable can be fixed under the speakers using Darkz Feet or by placing the speakers spikes in the centre hole of the unit.

### 3 > DARKZ CABLE LIFTER

This accessory creates a complete resonance free environment for your cables, another detail to reach optimum mechanical grounding. Darkz Cable Lifter is available in 4 Quality levels; D-TC, D2, C and A.



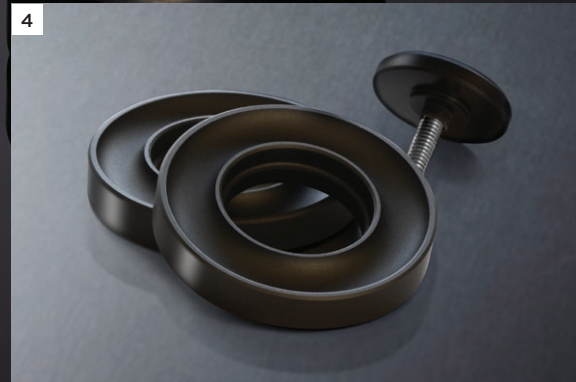
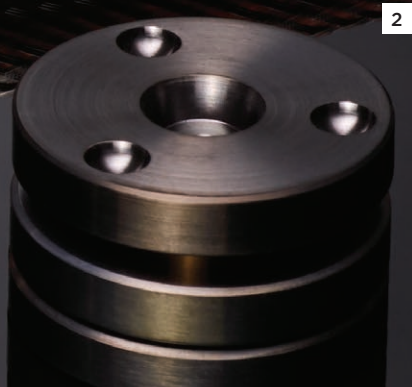

4 > DARKZ FEET

Darkz Feet is a stable base for fitting Darkz or Darkz Adjustable to your loudspeakers or racks. Darkz Feet are available in Aluminium level only.

## DARKZ | TITANIUM



For some time we have tested how titanium works in the Ansz Darkz as a resonance control element. The results are so successful that we have decided to start up a brand new line of Darkz, with titanium as essential building blocks.



BLACK  
Anodized aluminium  
Aluminium lock  
Titanium balls



BLUE  
Anodized aluminium  
Acoustically optimized coating  
Aluminium lock  
Titanium balls



PLUM  
Titanium  
Aluminium lock  
Titanium balls



RED  
Titanium  
Acoustically optimized coating  
Aluminium lock  
Titanium balls

# ANSUZ DARKZ | HOW TO ELIMINATE RESONANCE

Prevent Mechanical Vibrations/resonances with Ansz Darkz. Ansz Darkz is a series of efficient devices to ground all components in a High-End audio system. They are mechanically tuned to allow vibrations a path out of the component and to keep various components individually isolated.

To achieve the best result with Ansz Darkz resonance controls, there are some guidelines into how you should place them beneath your units. Please follow the guidelines as shown in these simple images and you will experience the amazing sonic improvement from these accessories.

## 1 > TURNTABLE

Normally, you want to replace the original feet with Ansz Darkz to achieve the best resonance control and mechanical grounding. However, if the turntable is originally fitted with solid feet, you can enhance the performance by placing Ansz Darkz Adjustable underneath the feet.



## 2 > TURNTABLE

Ansz Darkz is a much better choice than feet of soft materials like rubber. To further upgrade the performance and/or to achieve the right height, you can stack the Darkz.

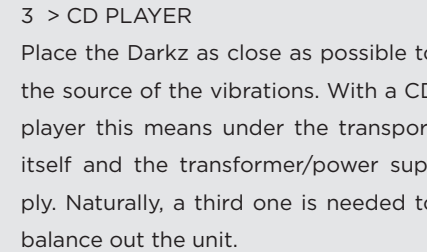
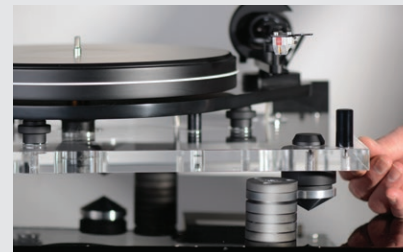
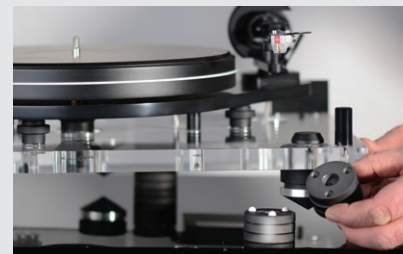

## 3 > CD PLAYER

Place the Darkz as close as possible to the source of the vibrations. With a CD player this means under the transport itself and the transformer/power supply. Naturally, a third one is needed to balance out the unit.

4



#### 4 > AMPLIFIER

When the Amplifier is fitted with Ansuz Feet, it is easy to mount Ansuz Darkz with three ceramic balls for each Darkz. Darkz Feet is available with screws in 4, 6 & 8 mm.

5



#### 5 > AMPLIFIER

When the Amplifier is fitted with Ansuz Darkz Feet, it is easy to mount Ansuz Darkz with three ceramic balls for each Darkz. Darkz Feet is available with screws in 4, 6 & 8 mm.

6



#### 5 > POWER DISTRIBUTOR

When the Power Distributor is fitted with Ansuz Feet, it is easy to mount Ansuz Darkz with three ceramic balls for each Darkz. Darkz Feet is available with screws in 4, 6 & 8 mm.

7

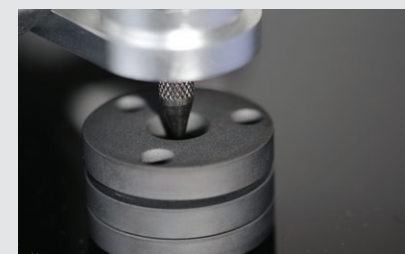

#### 6 > LOUDSPEAKERS

When fitted with Spikes, the mounting on Ansuz Darkz Adjustable is simple - just place the spikes in the center of the resonance control and level the speaker. Or even better - replace the spikes with Ansuz Darkz Feet and place them on Darkz with Ceramic Balls between.

# ANSUZ | TITANIUM RACK

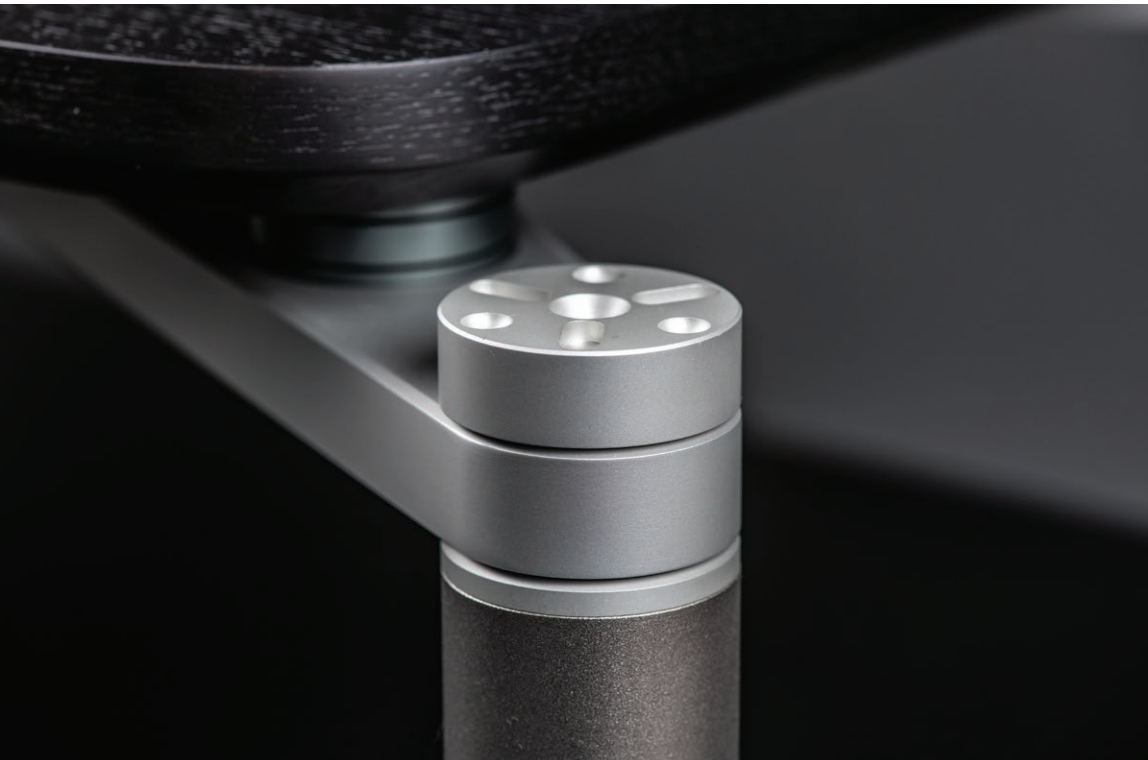

The highly acclaimed line of Darkz products set the stage for the evolution of the new Ansuz Rack. Both the Resonance Controlling and Mechanical Grounding techniques of the Darkz have been integrated into the sophisticated design of the Ansuz Rack.

Michael Børresen's creative ingenuity and years of professional experience have turned the Ansuz Rack into an outstanding high-end component reflecting the Ansuz grounding technology.

Each Rack module is available in four quality levels determined by the Darkz supporting the shelves:

- Aluminium
- Ceramic
- D2
- D-TC

Ansuz Rack modules are available in three different heights:

- Low: 120 mm
- Medium: 265 mm
- High: 382 mm

All these modules can be combined in a multitude of arrangements or used individually as amp-stands.

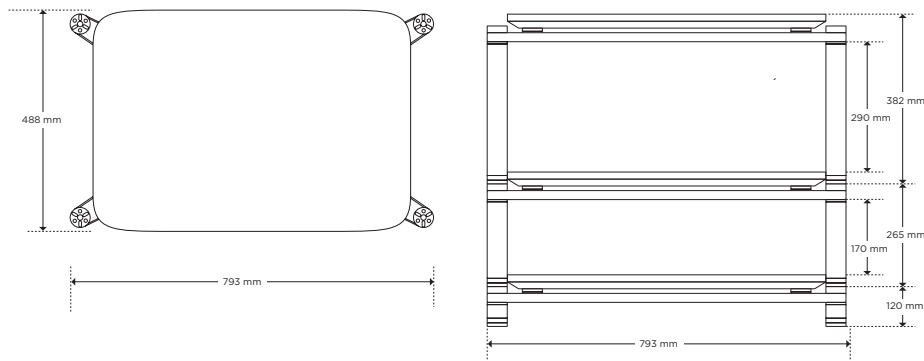



## ANSUZ SPARKZ | THE BLACK BEHIND THE MUSIC



The Ansz Sparkz is based on advanced Tesla Coil technology that when applied right, can serve as an active noise-suppressing element.

The Sparkz work in parallel to the mains feed by adding countersignals to detected noise. This is unlike most other power conditioners, where noise-suppressing elements are located in the power line, between the outlet and the electronic components. This restrains the amount of instantaneous current the equipment pulls from the mains.

The Ansz Sparkz is available in 2 versions: Sparkz and Sparkz TC



MADE IN DENMARK  
Sparkzite  
CE  
WWW.ANSUZ-ACOUSTICS.COM

MADE IN DENMARK  
Sparkzite  
CE  
WWW.ANSUZ-ACOUSTICS.COM

MADE IN DENMARK  
Sparkzite  
CE  
WWW.ANSUZ-ACOUSTICS.COM

MADE  
IN  
DENMARK  
DTC-00559





# ANSUZ ACOUSTICS | NAIM INTERCONNECTS

At Ansuz, we are proud to have had so many of the most renowned high-end audio journalists and experts visiting us. Many of our Ansuz partners from across the world have also been our guests here in Denmark. When we take them into our audio studios, we cannot resist the temptation to first expose them to a 'blind test' of musical performance. Concealed behind a curtain, we use a standard integrated NAIM amplifier combined with a matching CD player and upgrade it with all those products that represent state-of-the-art Ansuz audio technology: distributors, cables and resonance controlling devices.

Our guests' response has come as no surprise to us. They have always been completely stunned at the enormous extent of how much adding Ansuz products could advance the sound quality. The benchmarks of high-end musical performance and the passion for emotional musicality seem no longer to be mutually exclusive.

However, we were aware that when combining individual components into an integrated NAIM sound system, some of these up-grading effects were lost again. We soon identified the constraining factor. The typical 5-PIN interconnect with DIN plugs were in dire need of a heavy up-grade and some Ansuz magic.

So, based on our extensive know-how in cable engineering technology, we took on this exciting challenge and designed our first Ansuz interconnect, particularly customized to respond to all the specific needs of better integrating NAIM components into a complete sound system.

Once we fitted our Ansuz interconnect Xprototype into a NAIM music system, we were simply blown away by its mind-boggling impact it had on the musical performance. It by far exceeded all our expectations, elevating and refining all NAIM-typical sound properties: purity, clarity and authentic sound stage.

Eventually, we refined our original DIN X interconnect into two, even further advanced, versions.

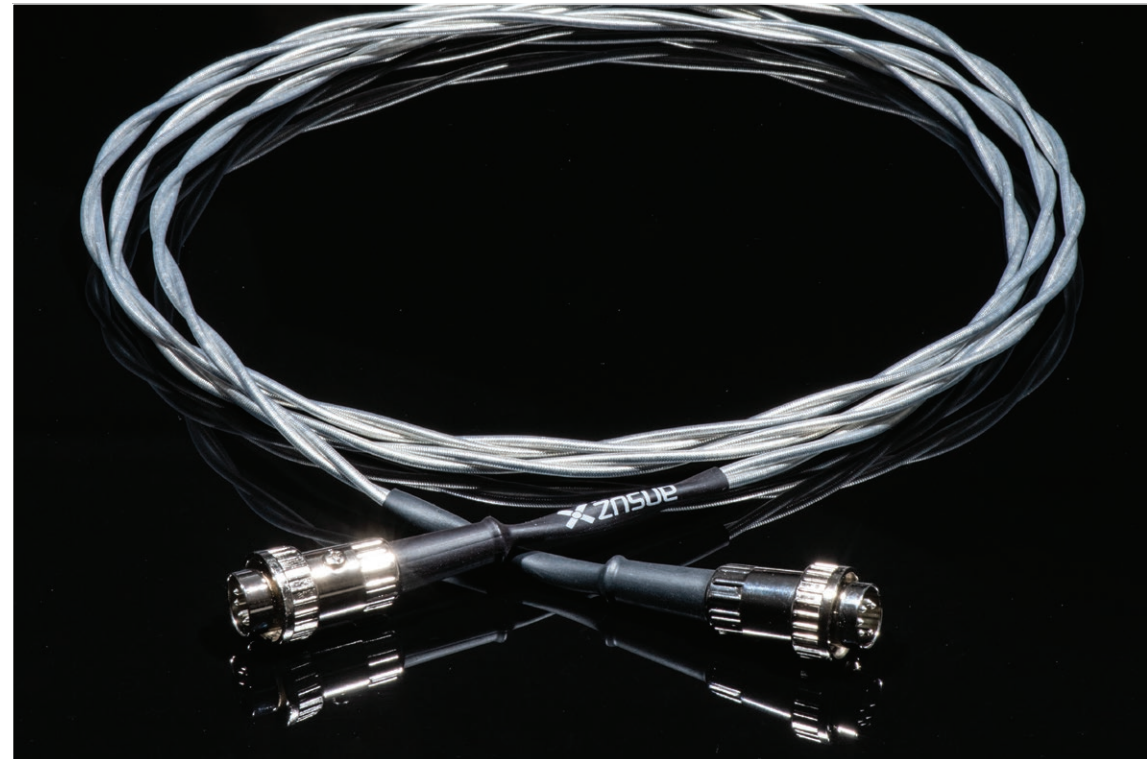

The DIN A2 interconnect will open up your NAIM sound system to an unprecedented free flow of music and propel purity, clarity and subtle refinement of a typical NAIM music stage into an absolutely new dimension. Indulge now in the full potential of an unsurpassed, pristine sound quality and enjoy music that has never been so crystal-clear and refined.

With Ansuz D2 interconnect everything falls into place. The best of NAIM components can now perform with their famous foot-tapping musicality. The high-end resolution and the musical dynamics embedded into a beautiful dark background will turn listening to music into an ultimate sensual experience.

# ESSENTIALS | GROUNDING AND SETUP

## 1 > MAINS OUTLET

The Mains outlet is where it all begins. From here your electronic devices draw the needed power. It can be an advantage to use a grounded outlet. However, if you have an Ansz Mainz8 power distributor in your system its not crucial.

## 2 > POWER CORD

The first power cord -from the wall outlet to the power distributor is the most important cable in any system - its with the quality of this power cord you set the level of performance the complete system can get.

## 3 > RESSONANCE CONTROL

If internal and external vibrations are not grounded properly, they will build up heavy resonances in all components with damaging effect.

## 4 > POWER DISTRIBUTOR

Your main component, the preamplifier/integrated amplifier must be connected to the main outlet (marked) of the Mainz8 power distributor. Doing this will minimize the ground potential between your devices and thus minimize ground current and Signal-induced fluctuations.

## 5 > CABLE LIFTER

Any cable that is subject to vibrations will have a tendency to act like a microphone. The cable will pick up the vi-

brations and create an unwanted signal. This is especially destructive with speaker wires as this induced signal will travel back into the feedback loop of the power amplifier causing a lot of disturbance. Naturally, grounding those vibrations is important. That is exactly what the Darkz Cable Lifters do.

## 6 > HIGH-END RACK

The Rack is the stabile base where you place your electronics. The quality of the Rack is vital to performance and naturally this must be mechanically grounded by adding ressonance controls e.g. Ansz Darkz

## 7 > POWER AMPLIFIER

The better Power Cord, the better performance of the Power Amplifier. This piece of electronics usually generates a vast amount of mechanical vibrations making grounding with resonance controls vital.

## 8 > SPEAKER WIRE

The Speaker Wire is the final connection that can be improved by using a quality Speaker Wire, leaving the rest up to the "lead singer": the Loudspeaker.

## 9 > RESSONANCE CONTROL

Ansz offers Darkz Feet, Darkz and Darkz Adjustable to handle the mechanical vibrations made in your Loudspeaker. (See page 29)

## 10 > POWER DISTRIBUTOR 2

You can achieve great improvements by adding more Power Distributors, linking the Power Distributors in a "Daisy Chain", securing a strong grounding base. Please ask your dealer how to do this correctly.

## 11 > ADJUSTABLE

When it comes to leveling your units e.g. the Turntable, you can do this by using an adjustable resonance control like Ansz Darkz Adjustable.

## 12 > TURNTABLE

Another very important cable is the Tonearm Cable, as it transfers an extremely weak and delicate signal from your tonearm/turntable to the phono-stage. Upgrading this cable is actually more important than upgrading the cartridge. Naturally, mechanical grounding is very important underneath a mechanical piece like the turntable.

## 13 > CD PLAYER

To get the most out of mechanically grounding your CD player, you must place the Darkz resonance controls as close to the source of vibrations as possible. Start with one Darkz directly underneath the mechanism, another one under the unit's power supply and then balance it out with a third Darkz. A quality power cord and digital/analog interconnects is equally important.

## 14 > MAIN GROUND POWER CORD

During the last decade, the importance of high quality power cords has come to nearly every audiophiles attention. Still, all power cords are not of the same importance, so you can prioritize between you components. Second to the power cord from the wall outlet to the power distributor, is the cable for the amplifier -integrated or pre-amp. From there it is analog sources before digital sources.

## 15 > PRE AMPLIFIER

The better Power Cord, the better performance of the Preamplifier. Also the distribution of signals to/from the Preamplifier will be significantly improved by using quality Interconnects.

## 16 > HARMONIZER

The Ansz Sparkz/Sparkz TC acts like small power conditioners - but without the drawbacks, as they work in parallel to the mains feed by adding counter-signals to detected noise. So, there are no restrains in the instantaneous current the electronics can pull from the mains. The result is a darker background to the music and enhanced dynamics. You can never have too many Sparkz in you system - more is more....

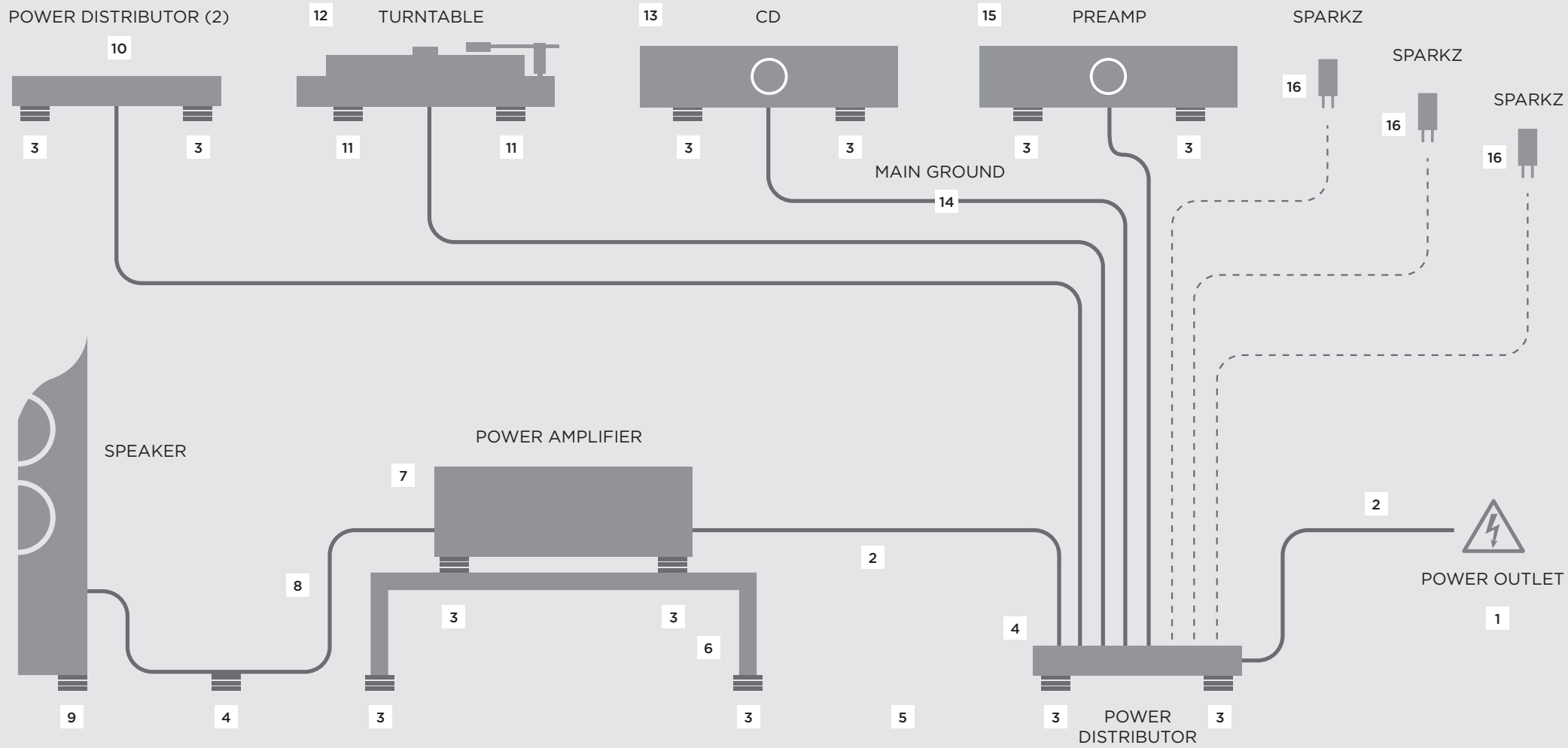

# ESSENTIALS | GROUNDING AND SETUP

## 1 > MAINS OUTLET

The Mains outlet is where it all begins. From here your electronic devices draw the needed power. It can be an advantage to use a grounded outlet. However, if you have an Ansz Mainz8 power distributor in your system its not crucial.

## 2 > POWER CORD

The first power cord -from the wall outlet to the power distributor is the most important cable in any system - its with the quality of this power cord you set the level of performance the complete system can get.

## 3 > RESSONANCE CONTROL

If internal and external vibrations are not grounded properly, they will build up heavy resonances in all components with damaging effect.

## 4 > POWER DISTRIBUTOR

Your main component, the preamplifier/integrated amplifier must be connected to the main outlet (marked) of the Mainz8 power distributor. Doing this will minimize the ground potential between your devices and thus minimize ground current and Signal-induced fluctuations.

## 5 > CABLE LIFTER

Any cable that is subject to vibrations will have a tendency to act like a microphone. The cable will pick up the vibrations

and create an unwanted signal. This is especially destructive with speaker wires as this induced signal will travel back into the feedback loop of the power amplifier causing a lot of disturbance. Naturally, grounding those vibrations is important. That is exactly what the Darkz Cable Lifters do.

## 6 > HIGH-END RACK

The Rack is the stabile base where you place your electronics. The quality of the Rack is vital to performance and naturally this must be mechanically grounded by adding ressonance controls e.g. Ansz Darkz

## 7 > POWER AMPLIFIER

The better Power Cord, the better performance of the Power Amplifier. This piece of electronics usually generates a vast amount of mechanical vibrations making grounding with resonance controls vital.

## 8 > SPEAKER WIRE

The Speaker Wire is the final connection that can be improved by using a quality Speaker Wire, leaving the rest up to the "lead singer": the Loudspeaker.

## 9 > RESSONANCE CONTROL

Ansz offers Darkz Feet, Darkz and Darkz Adjustable to handle the mechanical vibrations made in your Loudspeaker. (See page 29)

## 10 > POWER DISTRIBUTOR 2

You can achieve great improvements by adding more Power Distributors, linking the Power Distributors in a "Daisy Chain", securing a strong grounding base. Please ask your dealer how to do this correctly.

## 11 > ADJUSTABLE

When it comes to leveling your units e.g. the Turntable, you can do this by using an adjustable resonance control like Ansz Darkz Adjustable.

## 12 > TURNTABLE

Another very important cable is the Tonearm Cable, as it transfers an extremely weak and delicate signal from your tonearm/turntable to the phono-stage. Upgrading this cable is actually more important than upgrading the cartridge. Naturally, mechanical grounding is very important underneath a mechanical piece like the turntable.

## 13 > CD PLAYER

To get the most out of mechanically grounding your CD player, you must place the Darkz resonance controls as close to the source of vibrations as possible. Start with one Darkz directly underneath the mechanism, another one under the unit's power supply and then balance it out with a third Darkz. A quality power cord and digital/analog interconnects is equally important.

## 14 > MAIN GROUND POWER CORD

During the last decade, the importance of high quality power cords has come to nearly every audiophiles attention. Still, all power cords are not of the same importance, so you can prioritize between you components. Second to the power cord from the wall outlet to the power distributor, is the cable for the amplifier -integrated or pre-amp. From there it is analog sources before digital sources.

## 15 > PRE AMPLIFIER

The better Power Cord, the better performance of the Preamplifier. Also the distribution of signals to/from the Preamplifier will be significantly improved by using quality Interconnects.

## 16 > HARMONIZER

The Ansz Sparkz/Sparkz TC acts like small power conditioners - but without the drawbacks, as they work in parallel to the mains feed by adding counter-signals to detected noise. So, there are no restrains in the instantaneous current the electronics can pull from the mains. The result is a darker background to the music and enhanced dynamics. You can never have too many Sparkz in you system - more is more....

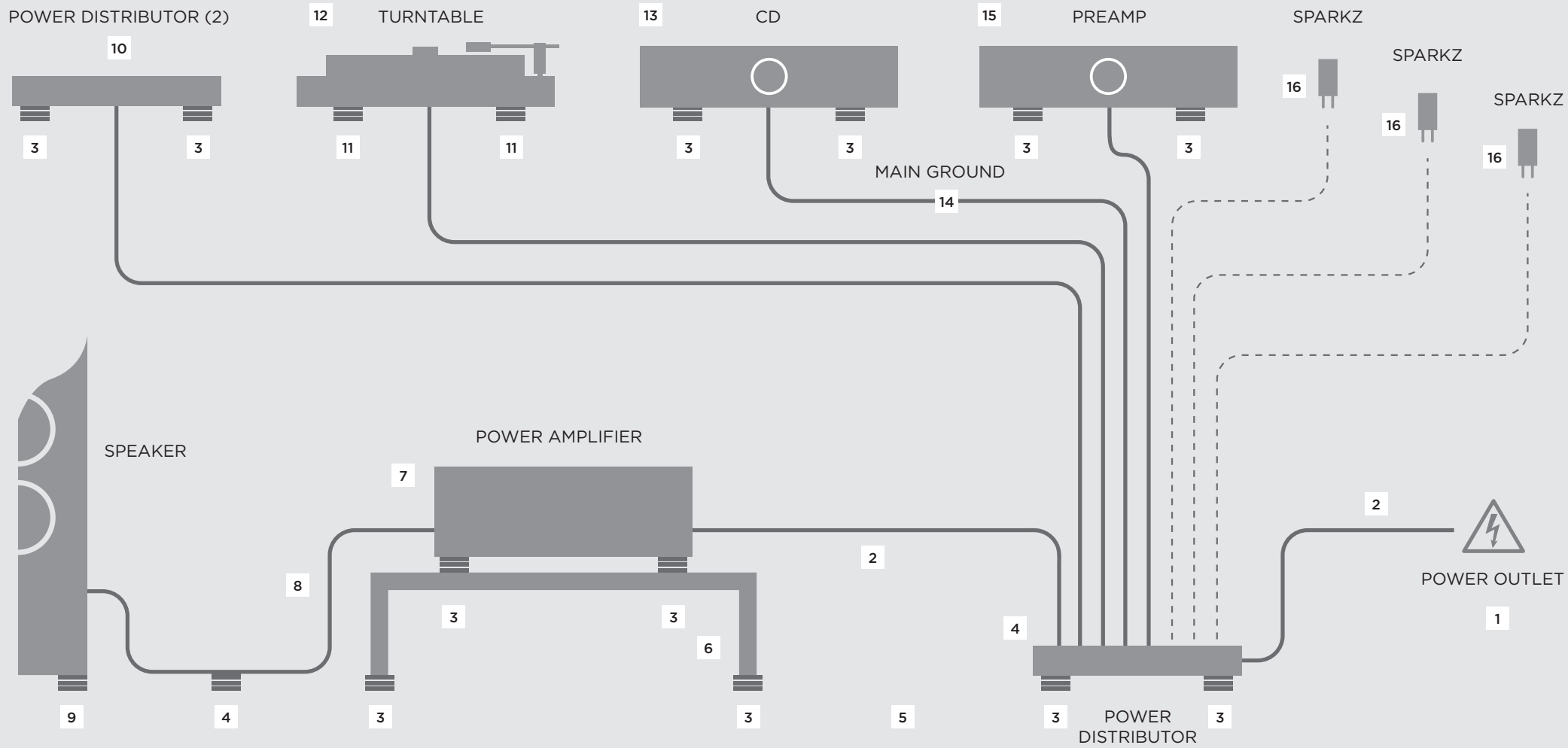

# ANSUZ ACOUSTICS | THE LEVELS

PRODUCTS	SUPREME	D-TC	T2	D2	C2	C	A2	A	P2	X
Power Cord	•	•		•	•		•		•	•
Speaker Wire		•		•	•		•		•	•
Interconnect RCA and XLR	•	•		•	•		•		•	•
Interconnect Digitalz RCA/RCA, BNC/RCA, BNC/BNC	•	•		•	•		•		•	•
Interconnect AES/EBU	•	•		•	•		•		•	
Interconnect Digitalz USB	•	•		•						•
Interconnect for NAIM - DIN to DIN, 5 pin				•			•			•
Phono Cable	•	•		•	•		•			
Jumpers		•		•	•		•		•	•
Powerbox	•	•		Optional*						
Power Distributor		•		•	•		•			• / TC
Darkz	T2S	•	•	D2T	C2T	•		•		
Darkz Adjustable	T2S	•	•	D2T	C2T	•		•		
Darkz Cable Lifter	T2S	•	•	D2T	C2T	•		•		
Darkz Feet								•		
Sparkz Harmonizer (not referring to specific quality level)	Sparkz / Sparkz TC									
Rack		•		•		•		•		

## EQUIPMENT & TECHNOLOGY

POM Housing, black										•
Anodized Aluminium Housing, Silver Satin				•	•		•		•	
Hard Anodized Aluminium Housing, Black		•								
3D Housing, Black		•		•						
Ansuz DGC Technology (Direct Ground Connector Technology)									•	
Ansuz DIHC Technology (Double Inverted Helix Coil Technology)		•		•	•		•	•	•	
Ansuz NSC Technology (Noise Suppressing Coil technology)		•							•	
Ansuz AARC Technology (Anti Arial Ressonance Coil)				•	•					
Active Tesla Coil Technology		•		•						
Dynamically Charged Dieletrikum		•		•						

\*) The Ansuz D2 can be played powered by the D-TC Powerbox as well as analogue.

## THE TEAM



LARS KRISTENSEN  
*Demos and sales*



FRITS DALMOSE  
*Demos and sales*



MORTEN THYRRESTRUP  
*Demos, sales and support*



EMIL KRISTENSEN  
*Sales and Support*



ANN PLAETNER  
*Commercial Manager*



MICHAEL BØRRESEN  
*Development and Press*



Ansuz Acoustics is a Danish company who develops, design, produces and sells cables, power distributors, resonance controls and accessories for High-End music systems.

At Ansuz we are committed to lead this narrow field to satisfy our passionate customers and clients, making any music system perform to its peak.

To meet our own high standards, we travel the world and do workshops to educate and share our passion with our partners and to assure that all customers gets not only the best products, but also get the best advice and service.

