



INSTRUCTION GUIDE: MK4 AND EX3 SERIES

NEEDED:

Stan's wheelset, 2 tires, Stan's Tire Sealant, valve core remover tool, injector or 2oz. bottle, floor pump or compressor, soapy water, safety goggles.

IMPORTANT NOTE:

Never inflate any tire without a tube above 40psi (2.8 bar) unless the tire is specifically labeled for tubeless use. Maximum pressure listed on your rims may differ from maximum pressure listed on your tires. Do not inflate above the lower of the two numbers.

1

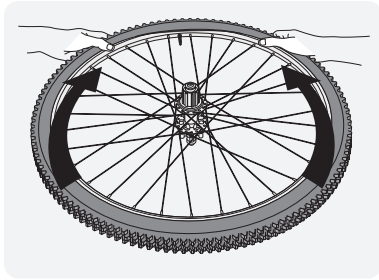

Mount tire: Making sure to position the tire bead in the center channel of the rim, mount one tire bead beginning opposite the valve and finishing at the valve. Once the first bead is mounted, begin mounting the second bead opposite the valve and finish at the valve.

2

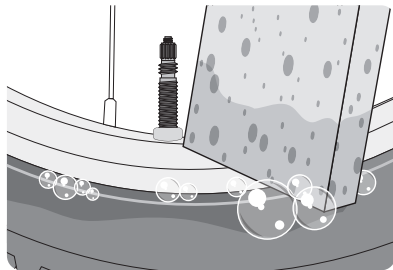

With a brush or sponge, apply a generous amount of soapy water to both beads of the tire to help it slip onto the bead of the rim when inflating.

3

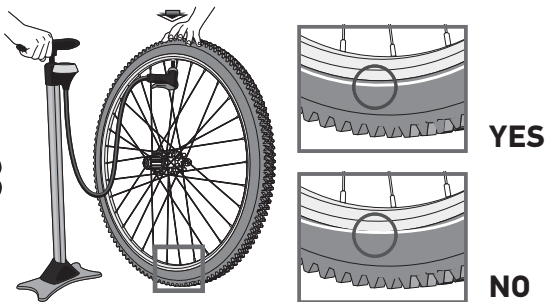

Rotate the valve to 12 o'clock, and install a pump. Inflate tire to 35psi (2.4 bar) to seat tire.

4

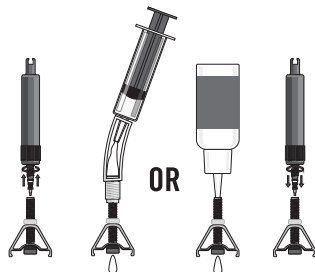

Add sealant: Once successful with inflation, remove the valve core to add Stan's sealant. Add 2-4oz. of sealant.

5

Inflate to preferred riding pressure. Always review the maximum pressure information listed on both the rim and tire and consider the lower of the two numbers your maximum pressure. Do not inflate above the lower of the two numbers.

6

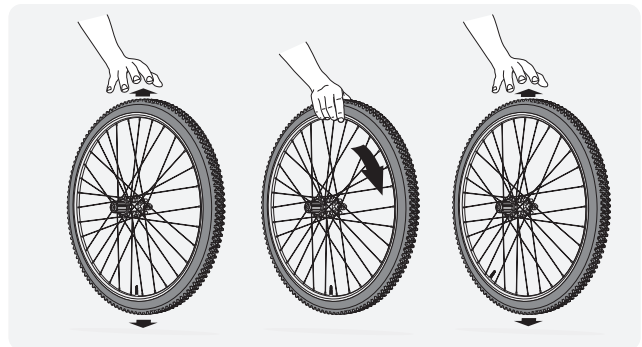

Bounce: Hold the wheel vertically and gently bounce or "dribble" it to disperse sealant throughout the inside of the tire. Let the wheel drop from an inch or two, then rotate a few degrees and repeat. Do this for several revolutions of the wheel.

7

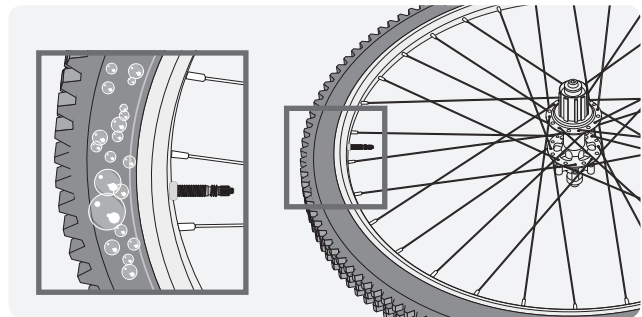

Lay tire on side and apply a thin sheen of soapy water around the sidewall and the bead area. Look for suds occurring anywhere on the tire or bead area. Suds bubbling out from the tire indicate porous areas. Shake the sealant to those areas to seal them and apply soap and water again. Check for suds forming on both sides of the tire. Repeat until no suds remain. Install the cassette and rotors according to the component manufacturer's recommendations.

STAN'S RIM AND WHEEL SETUP GUIDE: MK4, EX3 SERIES



RIMS	WEIGHT 26/27.5/29"	ERD	OFFSET	MAX SPOKE TENSION (KgF)	STAN'S BUILD TENSION (KgF)	TAPE WIDTH	VALVE
Crest MK4	357g/374g/399g	538/563/601	1.5mm	115	105	27	35mm Presta
Arch MK4	431g/451g/481g	536/561/600	2.5mm	130	105	30	35mm Presta
Flow MK4	466g/487g/521g	536/561/600	3.0mm	130	105	33	35mm Presta
Flow EX3	NA/580g/618g	NA/564/602	0.0mm	130	105	30	35mm Presta

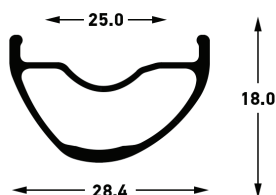

CREST MK4

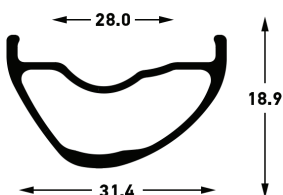

ARCH MK4

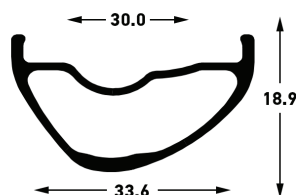

FLOW MK4

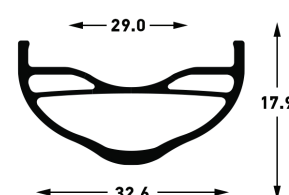

FLOW EX3

IMPORTANT: Stan's strongly recommends all wheels be assembled by a professional wheelbuilder, according to the specific instructions we offer here.

- Stan's rims are drilled at specific spoke angles to maximize strength and minimize weight, therefore proper drive-side and non-drive-side orientation and lacing are required for best performance. Before building, determine the lacing position by locating the valve hole and key spoke hole. This is easily done on an asymmetric (MK4) rim by identifying the 'long' side of the rim: for a rear wheel, the 'long' side will be on the drive-side while for a front wheel it will be on the disc-side. For a symmetric (EX3) rim, your key spoke should also be on the drive-side when building a rear wheel and the disc-side when building a front.
- 3-cross lacing is strongly recommended for 28 and 32-hole builds
- Please note recommended tensions for each rim.
- Sapim Secure Lock locking nipples and Stan's SRD Spoke Powder are highly recommended.
- If assembling with Stan's hubs, spoke lengths can be found at: <https://www.notubes.com/tech-docs>
- Warranty policies for aluminum rims can be found at: <https://www.notubes.com/warranty-info>
- Tape installation and additional how-to videos are available at: <https://www.notubes.com/help>

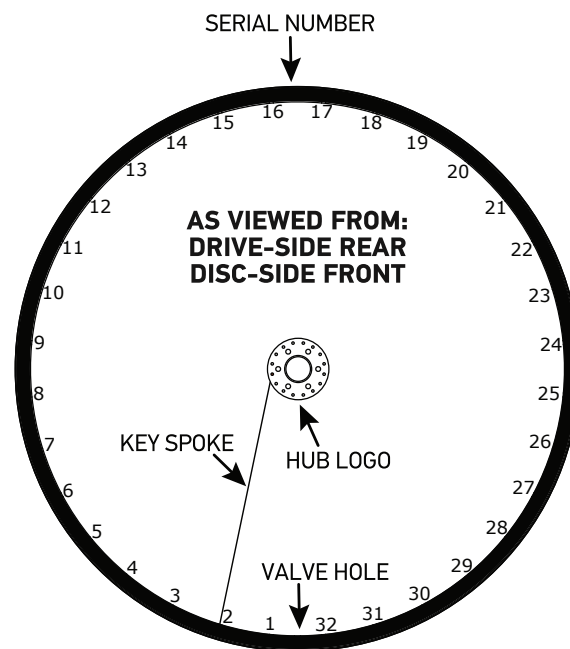

Caution: Stan's rims are optimized for tubeless use and designed to set up tubeless with Stan's Yellow Tape, Stan's valves, and Stan's sealant. Tubes may also be used on all Stan's rims; as with all tube installations, care must be taken to prevent tubes from being caught underneath the bead of the tire, causing the tire to dismount when inflated.

Rim Tape: Stan's Yellow Tape is designed for use with Stan's rims. Use of other tapes is not recommended. BST and BST-Asymmetric rims require one layer of Yellow Tape. See above chart for tape width.

Tubeless Setup: Important: Never inflate any tire without a tube above 40psi (2.8 bar) unless it is specifically labeled for tubeless use. Maximum pressure listed on your rims may differ from maximum pressure listed on your tires. Do not inflate above the lower of the two numbers.