

V1226-MPZ

f=12mm F2.6
for 1" type cameras, Fixed-focal
C-Mount

Model No.	V1226-MPZ		Effective	Front	φ 22.6mm		
Focal Length	12mm		Lens Aperture	Rear	φ 15.1mm		
Max. Aperture Ratio	1:2.6		Distortion	1 Type	0.0%		
Max. Image Format	12.8mm x 9.6mm(φ 16mm)			2/3 Type	-1.1%		
Operation Range	Iris	F2.6 - F16.0		1/1.8 Type	-1.0%		
	Focus	0.1m - Inf.		Back Focal Length	10.6mm		
Control	Iris	Manual		Flange Back Length	17.526mm		
	Focus	Manual		Mount	C-Mount		
Object Dimension at M.O.D.	1 Type	123.2mm x 91.9mm		Filter Size	M37.5 P=0.5mm		
	2/3 Type	84.1mm x 62.7mm		Dimensions	φ 39mm x 43.5mm		
	1/1.8 Type	68.5mm x 51.2mm		Weight	98.4g		
Angle of View	D	1 Type	67.4°	2/3 Type	49.8°	1/1.8 Type	41.5°
	H		56.7°		40.7°		33.7°
	V		44.1°		31.0°		25.5°
Operating Temperature	-10°C - +50°C						

M.O.D. : Minimum Object Distance

Dimensions

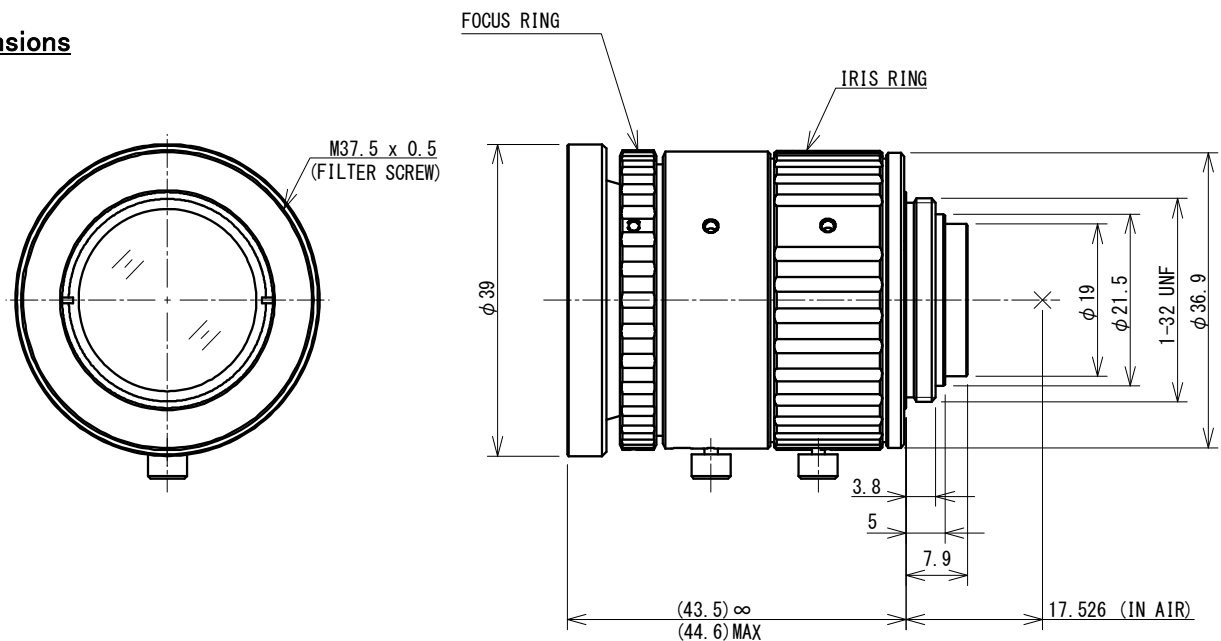

SCORPION VISION

shop.scorpion.vision +44 (0) 1590 679333 sales@scorpion.vision