

V0828-MPY2

f=8mm F2.8

for 1.1" type 12 Megapixel cameras, Fixed-focal

C-Mount

Model No.	V0828-MPY2		Effective	Front	φ 42.2mm					
Focal Length	8mm		Lens Aperture	Rear	φ 15.3mm					
Max. Aperture Ratio	1:2.8		Distortion	1.1 type	-0.6%					
Max. Image Format	14.2mm x 10.4mm(φ 17.6mm)			1 type	-1.7%					
Operation Range	Iris	F2.8 - F16.0		2/3 type	-2.8%					
	Focus	0.2m - Inf.	Back Focal Length	8.6mm						
Control	Iris	Manual	Flange Back Length	17.526mm						
	Focus	Manual	Mount	C-Mount						
Object Dimension at M.O.D.	1.1 Type	38cm x 27cm	Weight	157.4g						
	1 Type	34cm x 25cm	Dimensions	φ 57.5mm x 53.2mm						
	2/3 Type	23cm x 17cm		φ 75.0mm x 54.0mm (with VM0811)						
Filter Size(*)	-			φ 70.0mm x 54.0mm (with VM0810)						
Angle of View	D	1.1 Type	93.9°	1 Type	89.3°	2/3 Type	69.0°			
	H							83.0°	77.3°	57.3°
	V									
Operating Temperature	-10°C - +50°C									

M.O.D. : Minimum Object Distance

(*)For using filters, please attach either VM0811 or VM0810.

Dimensions

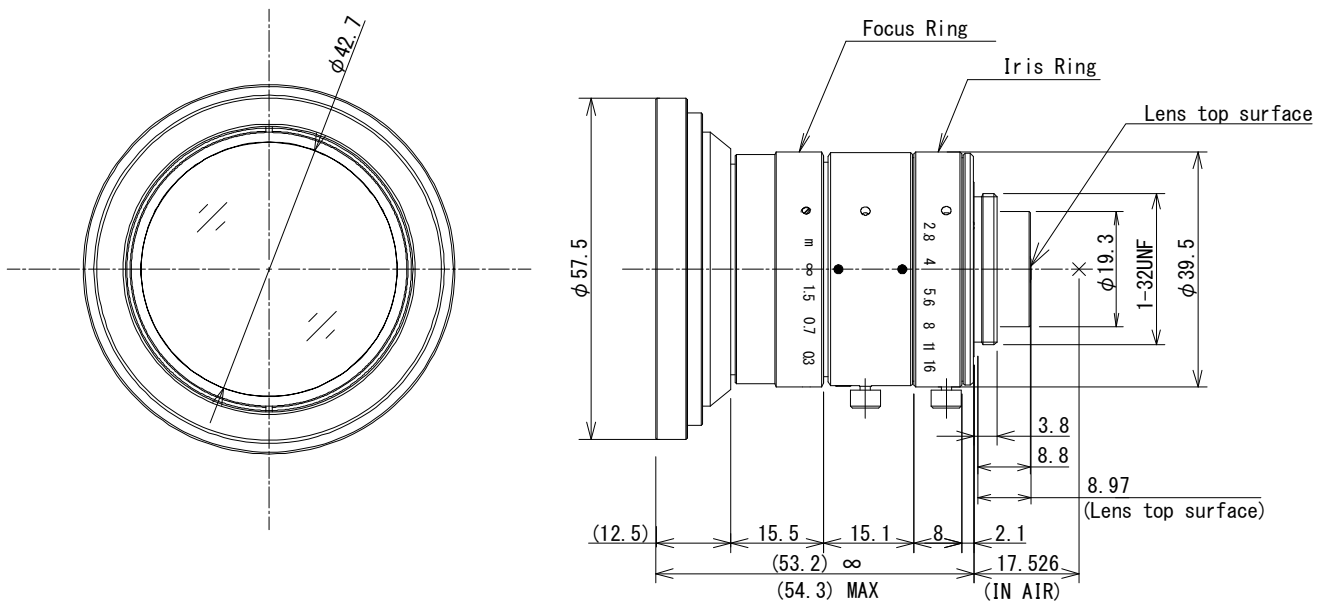

SCORPION VISION