



OAK-D-PRO-PoE



Overview

The OAK-D Pro PoE is an upgraded version of OAK-D-PoE, featuring IR laser dot projector (active stereo) and IR illumination LED (for night-vision). It's also smaller and lighter than the OAK-D-PoE.

It also has industrial M12 PoE connector (instead of RJ45) and additionally features M8 connector for IO connectivity; USB2 (D+, D-), camera IOs (FSIN, STROBE), power, and one auxiliary GPIO.

Hardware Specification

This OAK camera uses Power-over-Ethernet (PoE) for communication and power. It offers full 802.3af and Class 3 PoE compliance with 1000BASE-T speeds (1 Gbps). A PoE injector/switch is required to power the device. It also features IP65 rated enclosure. Future batches (manufactured in June 2023 or later) will have IP67 rated enclosures.



Camera Specification:

Camera Specs	Colour Camera	Stereo Pair
Sensor	IMX378 (PY004 AF, PY052 FF)	OV9282 (PY003)
Shutter	Rolling	Global
DFOV/HFOV/VFOV	81° / 69° / 55°	89° / 80° / 55°
Resolution	12MP (4056x3040)	1MP (1280x800)
Focus	AF: 8cm - ∞, FF: 50cm - ∞	FF: 19.6cm - ∞
Max Framerate	60 FPS	120 FPS
F-Number	1.8 ±5%	2.0 ±5%
Sensor Size	1/2.3"	1/4"
Effective Focal Length	4.81mm	2.35mm
Distortion	< 1% AF, < 1.5% FF	< 1%
Pixel Size	1.55µm x 1.55µm	3.0µm x 3.0µm

How it works

This OAK model has [notch IR filters at 940nm](#) on the stereo camera pair, allowing both visible and IR light from illumination LED/laser dot projector to be perceived by the camera.

Laser dot projector projects many small dots in front of the device, which helps with disparity matching, especially for low-visual-interest surfaces (blank surfaces with little to no texture), such as a wall or floor. The technique that we use is called [ASV](#) - conventional Active Stereo Vision - as stereo matching is performed on the device the same way as on OAK-D (passive stereo).

Note

Laser dot projector and flood LED are disabled by default! That's because most people would prefer intentionally enabling the laser dot projector when they are wearing eye safety gear

On the image below there's a blank wall with no texture. Without the dot projector, (passive) depth perception is poor. With the dot projector set to ~200mA, the (active) depth perception looks much better. If you look closely at the bottom left frame, you can see little dots all around the wall.

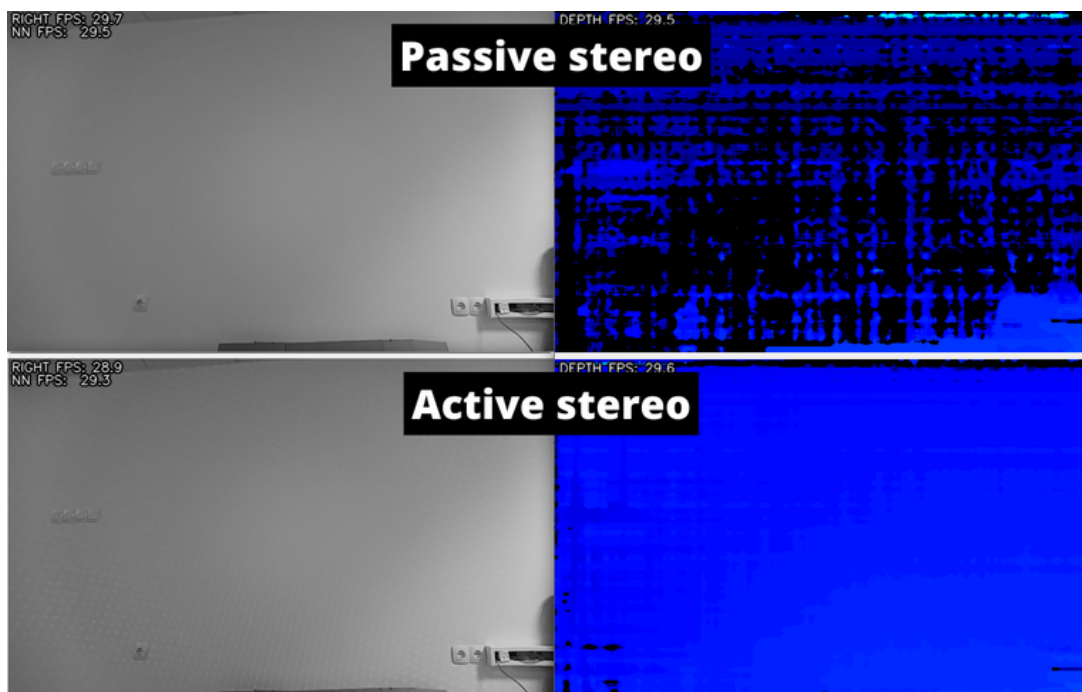

Flood IR LED illumination allows perceiving low-light and no-light environments. You can run your AI/CV processes on frames that are illuminated by the IR LED. Note that the colour camera doesn't perceive IR light, so you would need to use a mono camera stream for your AI/CV processes.



Getting started

You can set IR laser dot projector and illumination LED via the API as below. **Note** that the dot projector will be **strongest at 765mA**, as above that, the duty cycle will decrease.

Either within Script node:

```
script = pipeline.create(dai.node.Script)
script.setScript("""
    Device.setIrLaserDotProjectorBrightness(500)
    Device.setIrFloodLightBrightness(0)
""")
```

with dai.Device(pipeline) as device:

Or, using the dai.Device object from the host:

```
device.setIrLaserDotProjectorBrightness(100) # in mA, 0..1200
device.setIrFloodLightBrightness(0) # in mA, 0..1500
```

You can set these two parameters in **DepthAI Demo** in the Depth tab:

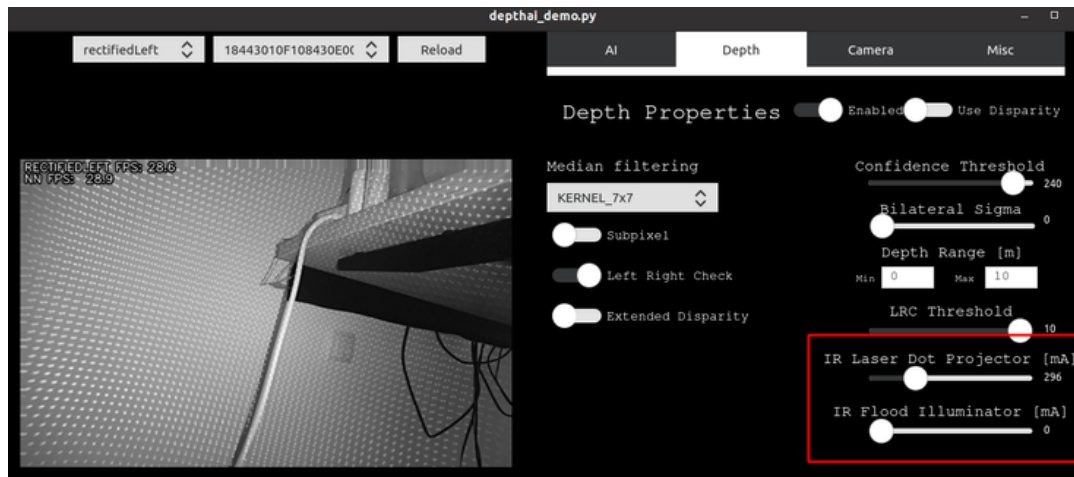

Projector Specs	Value
Dot projector	Ams Belago1.1 Dot-Pattern Infrared Illuminator
Number of dots	4700
HFOI* 50%	78 ± 7%
VFOI* 50%	61° ± 7%
VSCSEL wavelength	940nm
Operating temperature	10°C to ~60°C
Temperature absolute limits	0°C to ~80°C
PDF	Click here

FOI = Field of illumination. Also note that in datasheet, HFOI and VFOI are switched, that's because we mount the Belago1.1 rotated as we want greater horizontal field, to match field of cameras.

Regarding operating temperature; some customers use dot projector even at lower ambient temperatures, but first wait a few minutes for device to heat up (by running AI/CV/stereo depth...) so projector gets to above 0°C.

RVC2 inside

This OAK device is built on top of the RVC2. Main features:

- **4 TOPS** of processing power (1.4 TOPS for AI - RVC2 NN Performance)
- **Run any AI model**, even custom-architected/built ones (models need to be converted)
- **Encoding** H.264, H.265, MJPEG - 4K/30FPS, 1080P/60FPS
- **Computer Vision** warp/dewarp, resize, crop in ImageManip node, edge detection, feature tracking. You can also run custom CV functions
- **Object Tracking** 2D and 3D tracking with ObjectTracker node
- **Stereo Depth** perception with filtering, post-processing, RGB-depth alignment and high configurability

Connectors

M8 aux connector has 8pin female A-coded connector and the M12 ethernet has 8pin female X-coded connector.

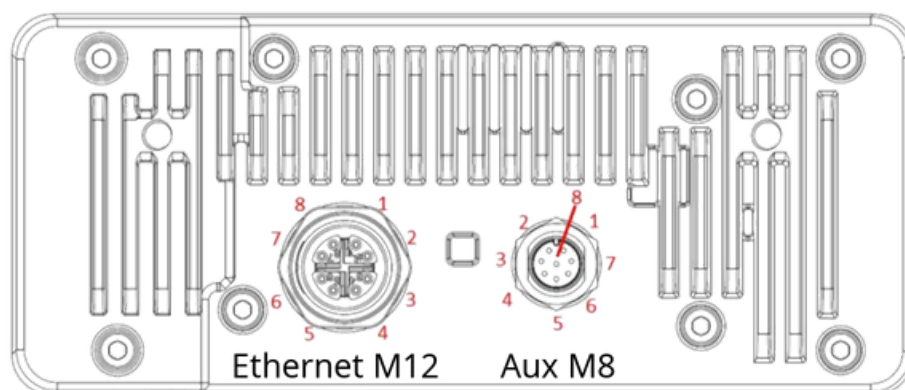

Connectors

	M12 Pin	M8 Pin	M8 Functionality
1	Eth MX0+	AUX GPIO 3V3	3V3 auxiliary GPIO 52. Pull this pin high with 10k resistor at startup for USB boot.
2	Eth MX0-	FSYNC ISO	Isolated Frame synchronization input signal for cameras
3	Eth MX1+	USB D+	USB 2.0 interface that can be used to connect to the OAK device (eg. reflash) if USB boot is enabled (via AUX GPIO 3V3).
4	Eth MX1-	USB D-	USB 2.0 interface that can be used to connect to the OAK device (eg. reflash) if USB boot is enabled (via AUX GPIO 3V3).
5	Eth MX3+	VBUSIN	This pin is used for sourcing 5V power to accessory devices connected to the M8 connector. If trying to boot the device in USB boot mode, this pin can also sink current.
6	Eth MX3-	Strobe ISO	Isolated Strobe output signal for cameras (Open Collector)
7	Eth MX2+	Isolated GND	Isolated ground for Strobe/FSYNC
8	Eth MX2-	GND	Ground.

Connectors

M8 aux connector has 8pin female A-coded connector and the M12 ethernet has 8pin female X-coded connector.

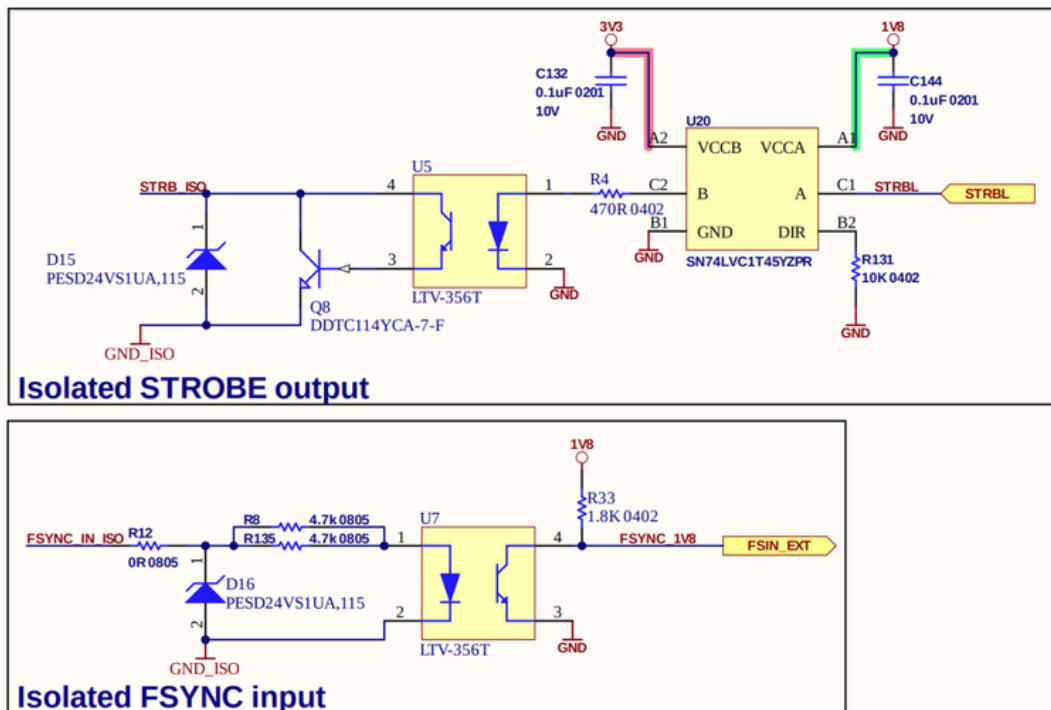

External Triggering: Sensors require 1V8 rising edge on FSYNC for the trigger event. We are using an optocoupler and ESD protection diode, so the input trigger voltage should be 12V (up to 24V) and the trigger logic is reversed, so trigger event happens at 0V on the FSYNC line. For example, see [External FSYNC Example](#).



Dimensions and Weight

Weight: 91g

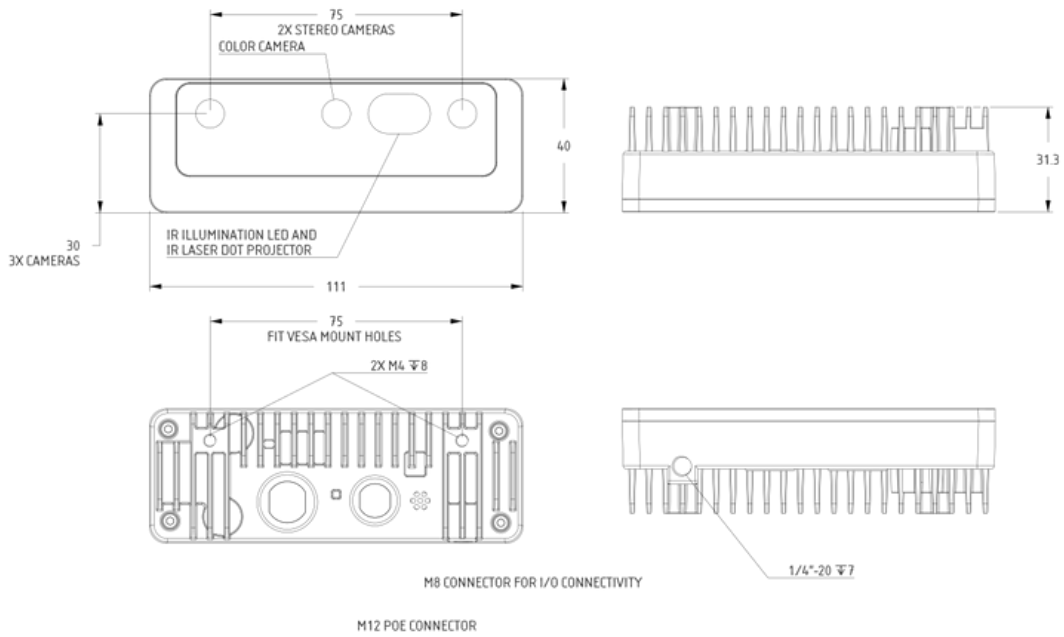



Stereo depth perception

This OAK camera has a baseline of 7.5cm - the distance between the left and the right stereo camera. Minimal and maximal depth perception (MinZ and Max) depends on camera FOV, resolution, and baseline- more information [here](#).

- Ideal range: 70cm - 8m
- MinZ: ~20cm (400P, extended), ~35cm (400P OR 800P, extended), ~70cm (800P)
- MaxZ: ~15 meters with a variance of 10% (depth accuracy evaluation)

Extended means that StereoDepth node has Extended disparity mode enabled.

Integrated IMU

This OAK camera has an integrated BNO085, a 9-axis IMU (Inertial Measurement Unit). See [IMU node](#) for the API details on how to use it.

Note: due to supply chain issues, most of the OAK camera that were manufactured between Q2 2021 and Q2 2023 have integrated BMI270 - 6-axis IMU instead.

Operating temperature

This device is rated to withstand temperatures within the range of -33° C - 55° C. Use in temperatures outside of this range may result in device failure.

Datasheet

- [Datasheet](#)

3D Models

- Board STEP files [here](#)
- Enclosure STEP files [here](#)



Laser safety

This product is classified as a Class 1 Laser Product under the EN/IEC 60825-1, Edition 3 (2014) internationally.

- Do not power on the product if any external damage was observed.
- Do not attempt to open any portion of this laser product.
- Invisible laser radiation when opened. Avoid direct exposure to the beam.
- There are no user serviceable parts with this laser product.
- Modification or service of the stereo module, specifically the infrared projector, may cause the emissions to exceed Class 1.
- No magnifying optical elements, such as eye loupes and magnifiers, are allowed.
- Do not try to update camera firmware that is not officially released for specific camera module and revision.

