

MVL-MF5028M-8MP 2/3" 50mm 8MP FA LENS

MF series FA series Lens are optimized for machine vision light sources and sensor, with high resolution, excellent image quality, high transmittance and good stability. Featured with fixed focal length, manual aperture and compact size, it is suitable for machine vision industry applications and ideal for industrial cameras.



Key Features

- Ultra-high resolution and consistency of image clarity
- Ultra-low distortion and higher relative illumination
- Achromatic optical system design, better image performance with color camera
- Supports ultra-short working distance with good optical performance
- Compact design, excellent vibration resistance and high and low temperature performance

Distortion

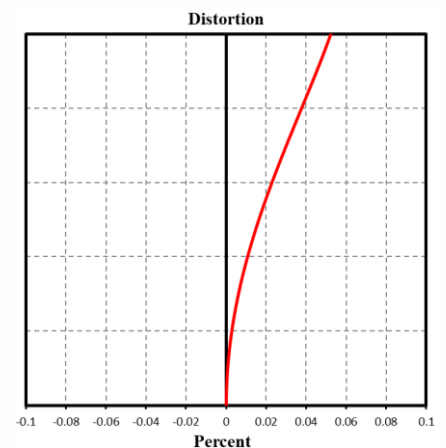

MTF

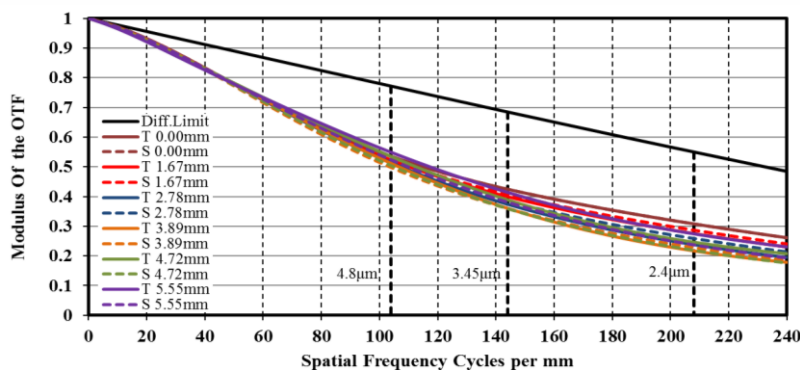

Relative Illumination

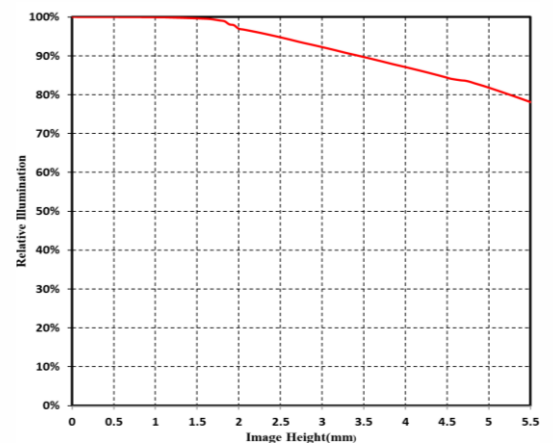

Note: The above curves are the simulate results based on F2.8, $\beta=-0.076$, WD=700 mm.



Specification

Model	MVL-MF5028-8MP
Parameter	Fixed focal length, Manual iris, 8MP, FA Lens
Performance	
Focal Length	50 mm
F-Number	F2.8 ~ F16
Image Size	Φ11 mm(2/3")
Distortion	0.01%
Minimum Operation Distance	0.4 m
Field of View	D (11.1 mm): 11.67° H (8.45 mm): 8.81° V (7.07 mm): 7.38°
Mechanical	
Iris Control	Manual Operation
Focus Control	Manual Operation
Filter Thread	M27×0.5
Mount	C-Mount
Flange Back Length	17.526 mm
Dimension	Φ29×53.81 mm
Weight	75.5 g
Temperature	-10 ~ 50°C
General	
Certification	RoHS2.0

Dimension

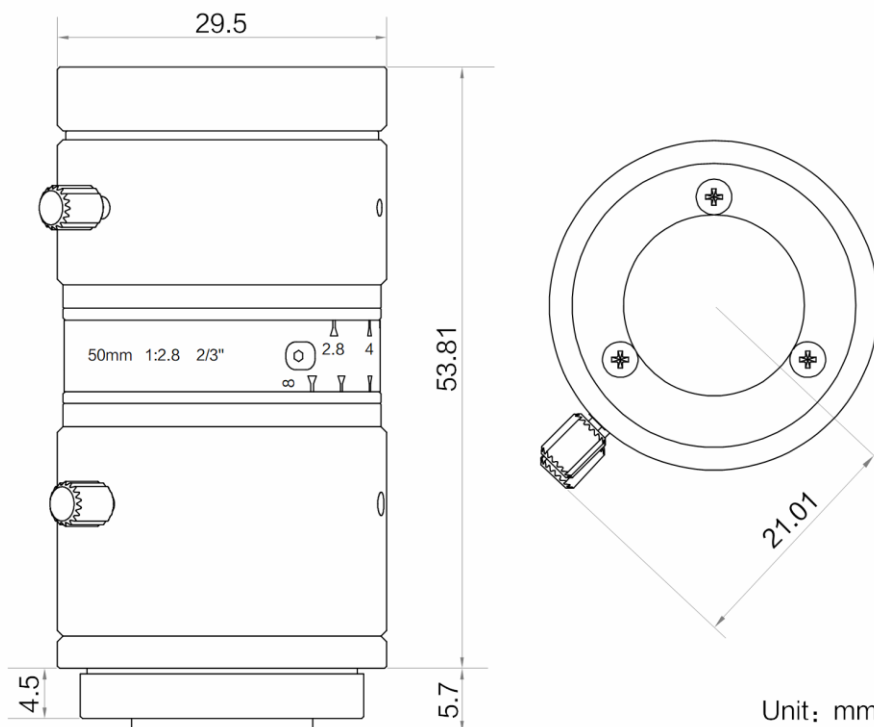

Field of View

Extension (mm)	Working Distance (mm)		Magnification	Field of View (mm)					
				2/3"		1/1.8"		1/2"	
				H(8.45mm)	V(7.07mm)	H(7.38mm)	V(4.92mm)	H(6.22mm)	V(4.67mm)
20	near	128.74	-0.540	15.65	13.09	13.66	9.11	11.52	8.65
	far	154.43	-0.401	21.10	17.65	18.43	12.28	15.53	11.66
10	near	183.20	-0.340	24.85	20.79	21.70	14.47	18.29	13.73
	far	279.00	-0.201	42.14	35.26	36.81	24.54	31.02	23.29
5	near	244.40	-0.240	35.19	29.45	30.74	20.49	25.91	19.45
	far	527.10	-0.101	84.08	70.35	73.43	48.96	61.89	46.47
2	near	313.80	-0.180	46.92	39.26	40.98	27.32	34.54	25.93
	far	1264.20	-0.041	208.64	174.57	182.22	121.48	153.58	115.31
1	near	348.50	-0.160	52.78	44.16	46.10	30.73	38.85	29.17
	far	2468.60	-0.021	412.20	344.88	360.00	240.00	303.41	227.80
0		400	-0.140	60.32	50.47	52.68	35.13	44.41	33.34
		450	-0.123	68.93	57.68	60.20	40.14	50.75	38.10
		500	-0.109	77.51	64.86	67.70	45.14	57.06	42.85
		550	-0.098	86.06	72.01	75.17	50.12	63.36	47.57
		600	-0.089	94.60	79.16	82.63	55.09	69.64	52.29
		650	-0.082	103.11	86.28	90.07	60.05	75.92	57.00
		700	-0.076	111.63	93.41	97.51	65.01	82.19	61.71
		750	-0.070	120.13	100.52	104.93	69.96	88.45	66.41
		800	-0.066	128.63	107.64	112.35	74.91	94.70	71.11
		850	-0.062	137.13	114.75	119.78	79.86	100.96	75.80
		900	-0.058	145.62	121.85	127.19	84.80	107.21	80.42
		950	-0.055	154.10	128.95	134.60	89.74	113.45	85.18
		1000	-0.052	162.58	136.04	142.00	94.68	119.69	89.87

Distribution Partner:



**SCORPION
VISION**