

MVL-MF3528M-8MP 2/3" 35mm 8MP FA LENS

MF series FA series Lens are optimized for machine vision light sources and sensor, with high resolution, excellent image quality, high transmittance and good stability. Featured with fixed focal length, manual aperture and compact size, it is suitable for machine vision industry applications and ideal for industrial cameras.



Key Features

- Ultra-high resolution and consistency of image clarity
- Ultra-low distortion and higher relative illumination
- Achromatic optical system design, better image performance with color camera
- Supports ultra-short working distance with good optical performance
- Compact design, excellent vibration resistance and high and low temperature performance

Distortion

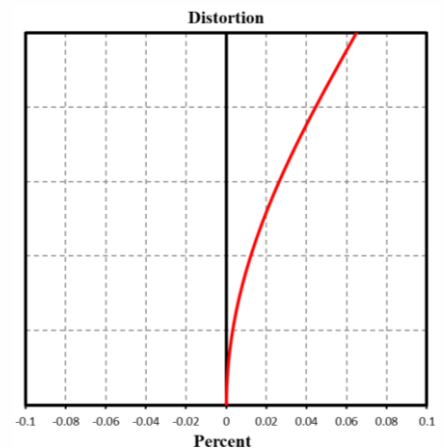

MTF

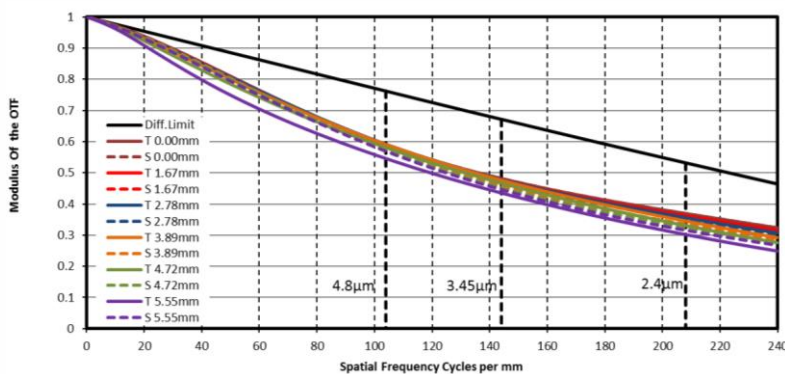

Relative Illumination

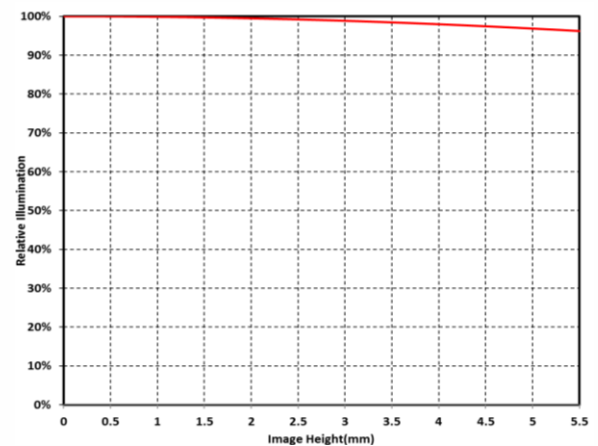

Note: The above curves are the simulate results based on F2.8, $\beta=-0.124$, WD=300 mm.



Specification

Model	MVL-MF3528M-8MP
Parameter	Fixed focal length, Manual iris, 8MP, FA Lens
Performance	
Focal Length	35 mm
F-Number	F2.8 ~ F16
Image Size	Φ11 mm(2/3")
Distortion	0.02%
Minimum Operation Distance	0.15 m
Field of View	D (11.1 mm): 15.26° H (8.45 mm): 11.65° V (7.07 mm): 9.76°
Mechanical	
Iris Control	Manual Operation
Focus Control	Manual Operation
Filter Thread	M30.5 × 0.5
Mount	C-Mount
Flange Back Length	17.526 mm
Dimension	Φ32 × 48.43 mm
Weight	84.3 g
Temperature	-10 ~ 50°C
General	
Certification	RoHS2.0

Dimension

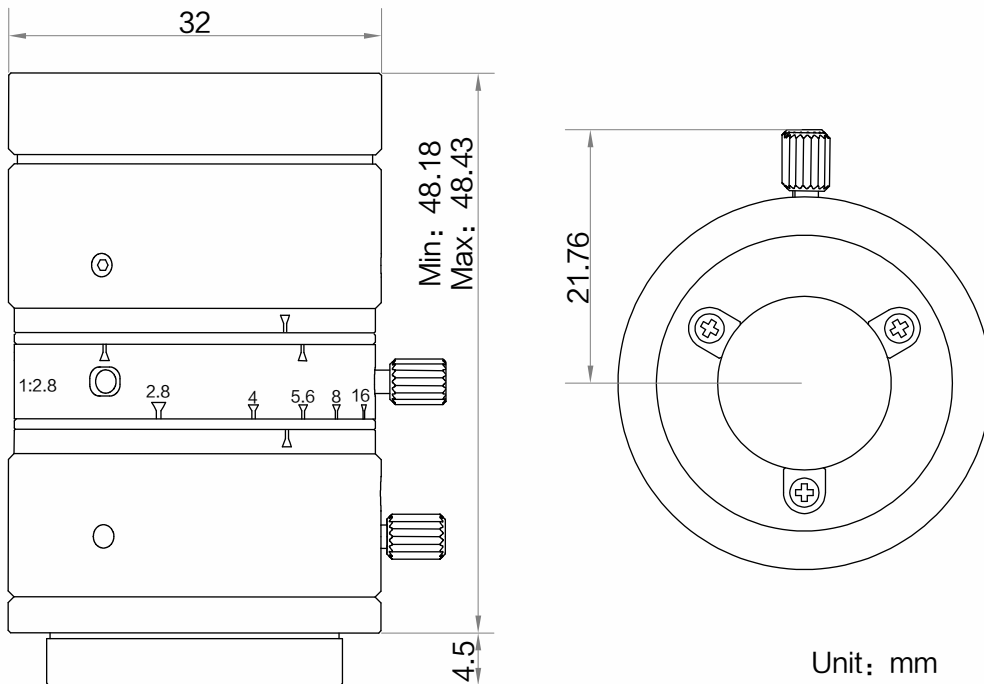

Field of View

Extension (mm)	Working Distance (mm)		Magnification	Field of View(mm)					
				2/3"		1/1.8"		1/2"	
				H(8.45mm)	V(7.07mm)	H(7.38mm)	V(4.92mm)	H(6.22mm)	V(4.67mm)
10	near	90.31	-0.577	14.65	12.26	12.80	8.53	10.79	8.10
	far	132.64	-0.286	29.54	24.71	25.80	17.20	21.74	16.33
5	near	110.29	-0.434	19.48	16.30	17.01	11.34	14.34	10.76
	far	254.69	-0.143	59.01	49.37	51.53	34.36	43.43	32.61
2	near	130.15	-0.348	24.27	20.31	21.20	14.13	17.87	13.41
	far	619.06	-0.057	146.97	122.97	128.36	85.58	108.19	81.23
1	near	139.14	-0.320	26.44	22.12	23.09	15.40	19.46	14.61
	far	1220.47	-0.029	292.17	244.46	255.17	170.12	215.07	161.47
0		150	-0.262	32.32	27.04	28.23	18.82	23.79	17.87
		200	-0.190	44.57	37.29	38.93	25.96	32.81	24.64
		250	-0.150	56.57	47.34	49.41	32.95	41.65	31.27
		300	-0.124	68.45	57.28	59.79	39.87	50.40	37.84
		350	-0.105	80.28	67.18	70.12	46.76	59.10	44.38
		400	-0.092	92.06	77.04	80.41	53.62	67.78	50.90
		450	-0.081	103.83	86.88	90.69	60.47	76.44	57.40
		500	-0.073	115.57	96.71	100.95	67.31	85.09	63.89
		550	-0.066	127.31	106.53	111.20	74.15	93.73	70.38
		600	-0.061	139.03	116.34	121.44	80.98	102.36	76.86
		650	-0.056	150.75	126.15	131.67	87.80	110.99	83.34
		700	-0.052	162.46	135.95	141.91	94.62	119.61	89.82
		750	-0.049	174.17	145.75	152.13	101.44	128.23	96.29
		800	-0.045	185.87	155.54	162.35	108.26	136.85	102.76
		850	-0.043	197.57	165.33	172.57	115.07	145.46	109.23
		900	-0.040	209.27	175.12	182.79	121.89	154.08	115.70
		950	-0.038	220.97	184.91	193.01	128.70	162.69	122.16
	1000	-0.036	232.66	194.69	203.22	135.51	171.30	128.63	

Distribution Partner:



**SCORPION
VISION**