



# MVL-MF1628M-8MP 2/3" 16mm 8MP FA LENS

MF series FA Lens are optimized for machine vision light sources and sensor, with high resolution, excellent image quality, high transmittance and good stability. Featured with fixed focal length, manual aperture and compact size, it is suitable for machine vision industry applications and ideal for industrial cameras.



## Key Features

- Ultra-high resolution and consistency of image clarity
- Ultra-low distortion and higher relative illumination
- Achromatic optical system design, better image performance with color camera
- Supports ultra-short working distance with good optical performance
- Compact design, excellent vibration resistance and high and low temperature performance

## Distortion

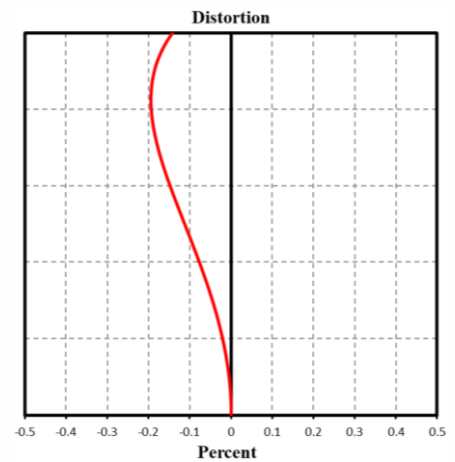

## MTF

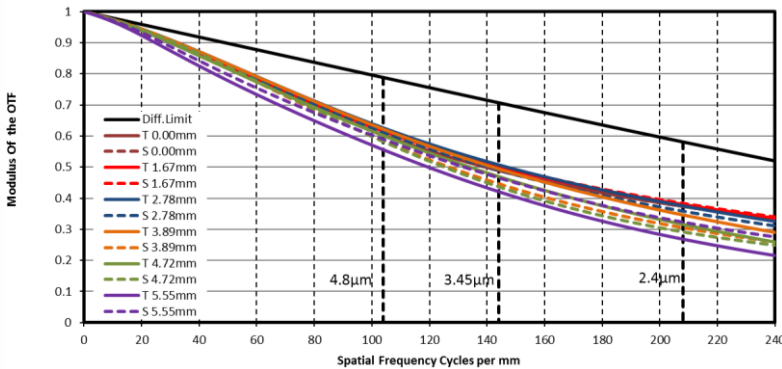

## Relative Illumination

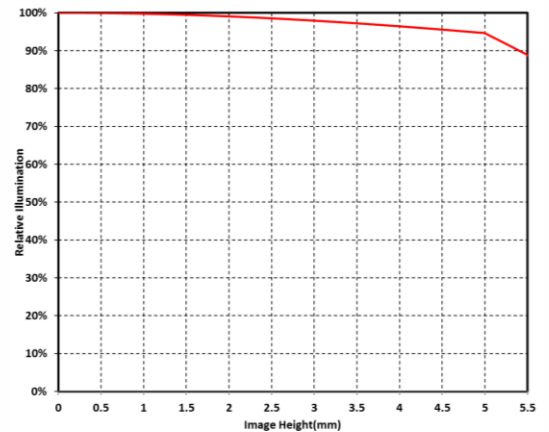

Note: The above curves are the simulate results based on F2.8, β=-0.051, WD=300 mm.



## Specification

Model	MVL-MF1628M-8MP
Parameter	Fixed focal length, Manual iris, 8MP, FA Lens
<b>Performance</b>	
Focal Length	16 mm
F-Number	F2.8 ~ F16
Image Size	Φ11 mm(2/3")
Distortion	0.33%
Minimum Operation Distance	0.1 m
Field of View	D (11.1 mm) : 37.39° H (8.45 mm) : 28.9° V (7.07 mm) : 24.33°
<b>Mechanical</b>	
Iris Control	Manual Operation
Focus Control	Manual Operation
Filter Thread	M27×0.5
Mount	C-Mount
Flange Back Length	17.526 mm
Dimension	Φ28.5×39.33 mm
Weight	57.1 g
Temperature	-10 ~ 50°C
<b>General</b>	
Certification	RoHS2.0

## Dimension

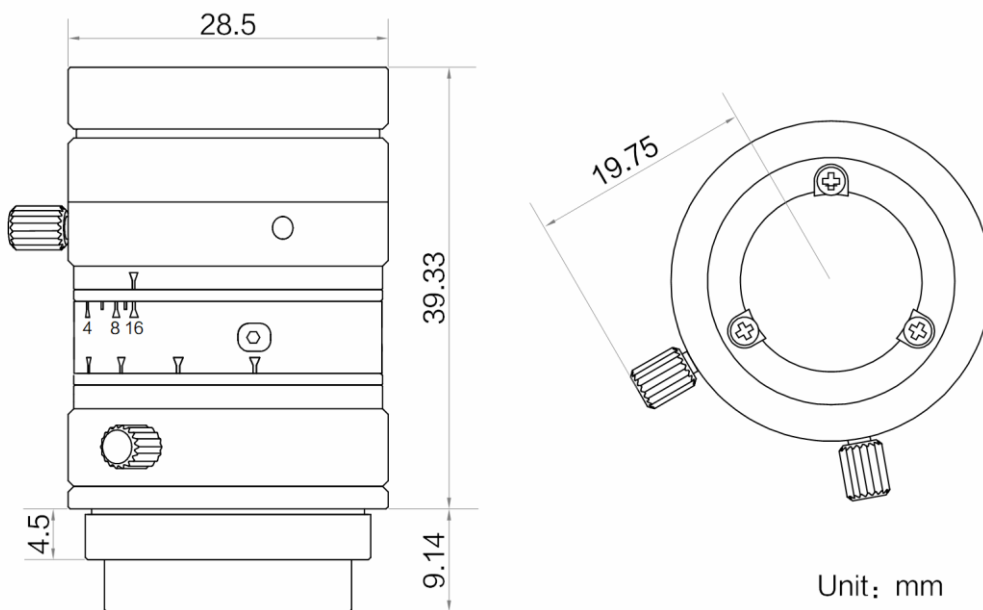

## Field of View

Extension (mm)	Working Distance (mm)		Magnification	Field of View(mm)					
				2/3"		1/1.8"		1/2"	
				H(8.45mm)	V(7.07mm)	H(7.38mm)	V(4.92mm)	H(6.22mm)	V(4.67mm)
5	near	20.98	-0.450	18.80	15.73	16.42	10.95	13.84	10.39
	far	33.66	-0.313	27.03	22.61	23.60	15.74	19.89	14.94
2	near	46.45	-0.262	32.25	26.98	28.17	18.78	23.74	17.82
	far	110.33	-0.125	67.51	56.49	58.96	39.31	49.70	37.31
1	near	65.58	-0.200	42.36	35.44	36.99	24.66	31.18	23.41
	far	237.84	-0.063	134.85	112.83	117.78	78.52	99.27	74.53
0		100	-0.134	63.47	53.05	55.39	36.86	46.64	34.98
		150	-0.095	89.78	75.05	78.36	52.16	65.99	49.50
		200	-0.073	115.89	96.90	101.17	67.36	85.22	63.93
		250	-0.060	141.90	118.68	123.89	82.51	104.37	78.31
		300	-0.050	167.87	140.41	146.58	97.64	123.49	92.67
		350	-0.044	193.81	162.12	169.24	112.74	142.59	107.01
		400	-0.039	219.72	183.81	191.88	127.84	161.68	121.34
		450	-0.034	245.63	205.49	214.51	142.93	180.76	135.66
		500	-0.031	271.52	227.17	237.14	158.01	199.83	149.97
		550	-0.028	297.41	248.83	259.75	173.09	218.89	164.28
		600	-0.026	323.29	270.50	282.36	188.17	237.95	178.59
		650	-0.024	349.16	292.15	304.97	203.24	257.01	192.90
		700	-0.023	375.03	313.81	327.57	218.31	276.06	207.21
		750	-0.021	400.88	335.46	350.17	233.40	295.12	221.53
		800	-0.020	426.76	357.11	372.77	248.45	314.16	235.82
		850	-0.019	452.63	378.76	395.37	263.52	333.21	250.11
		900	-0.018	478.49	400.41	417.97	278.58	352.26	264.41
	950	-0.017	504.35	422.06	440.56	293.65	371.30	278.71	
	1000	-0.016	530.21	443.70	463.15	308.71	390.35	293.01	

Distribution Partner:



**SCORPION  
VISION**