

MVL-MF1228M-8MP 2/3" 12mm 8MP FA LENS

MF series FA Lens are optimized for machine vision light sources and sensor, with high resolution, excellent image quality, high transmittance and good stability. Featured with fixed focal length, manual aperture and compact size, it is suitable for machine vision industry applications and ideal for industrial cameras.



Key Features

- Ultra-high resolution and consistency of image clarity
- Ultra-low distortion and higher relative illumination
- Achromatic optical system design, better image performance with color camera
- Supports ultra-short working distance with good optical performance
- Compact design, excellent vibration resistance and high and low temperature performance

Distortion

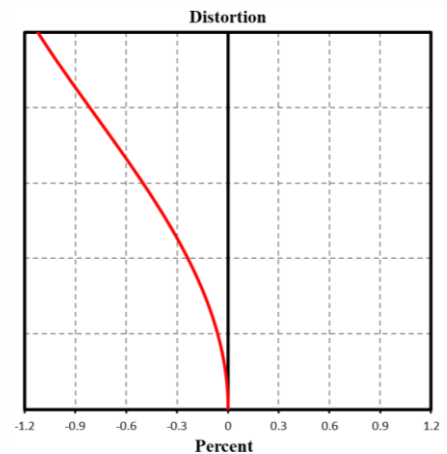

MTF

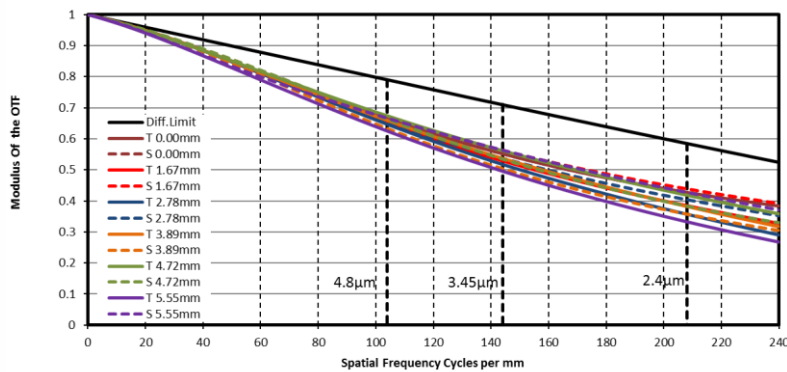

Relative Illumination

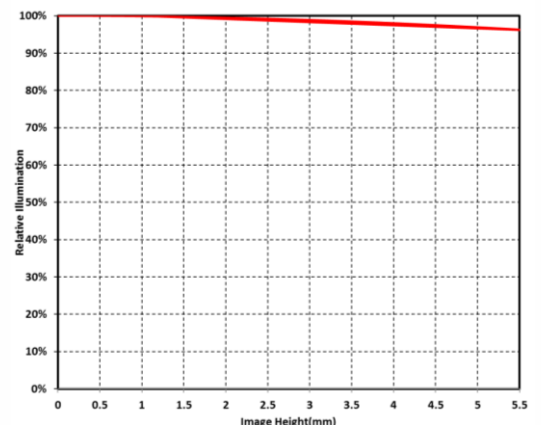

Note: The above curves are the simulate results based on F2.8, $\beta = -0.038$, WD=300 mm.



Specification

Model	MVL-MF1228M-8MP
Parameter	Fixed focal length, Manual iris, 8MP, FA Lens
Performance	
Focal Length	12 mm
F-Number	F2.8 ~ F16
Image Size	Φ11 mm(2/3")
Distortion	0.28%
Minimum Operation Distance	0.1 m
Field of View	D (11.1 mm) : 48.57° H (8.45 mm) : 37.88° V (7.07 mm) : 32.04°
Mechanical	
Iris Control	Manual Operation
Focus Control	Manual Operation
Filter Thread	M30.5 × 0.5
Mount	C-Mount
Flange Back Length	17.526 mm
Dimension	Φ32 × 39.4 mm
Weight	75.1 g
Temperature	-10 ~ 50°C
General	
Certification	RoHS2.0

Dimension

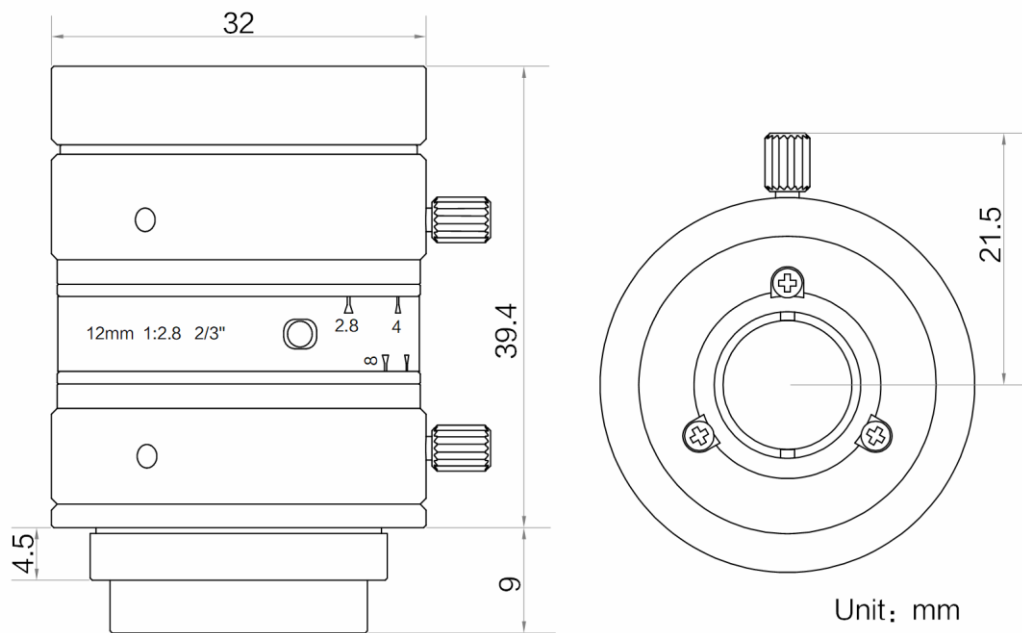

Field of View

Extension (mm)	Working Distance (mm)		Magnification	Field of View(mm)					
				2/3"		1/1.8"		1/2"	
				H(8.45mm)	V(7.07mm)	H(7.38mm)	V(4.92mm)	H(6.22mm)	V(4.67mm)
5	near	5.76	-0.522	16.20	13.55	14.15	9.43	11.92	8.95
	far	10.32	-0.417	20.27	16.96	17.71	11.80	14.92	11.20
2	near	26.93	-0.272	31.10	26.02	27.17	18.11	22.90	17.19
	far	53.48	-0.167	50.66	42.39	44.25	29.50	37.29	28.00
1	near	46.48	-0.188	44.87	37.54	39.19	26.12	33.03	24.80
	far	125.32	-0.083	101.25	84.72	88.43	58.96	74.53	55.96
0		100	-0.103	83.39	69.55	72.65	48.20	61.08	45.74
		150	-0.072	118.31	98.72	103.11	68.46	86.72	64.96
		200	-0.056	153.13	127.82	133.49	88.67	112.30	84.14
		250	-0.045	187.90	156.88	163.83	108.86	137.85	103.29
		300	-0.038	222.63	185.91	194.14	129.02	163.37	122.43
		350	-0.033	257.35	214.93	224.44	149.18	188.88	141.56
		400	-0.029	292.07	243.94	254.73	169.33	214.39	160.69
		450	-0.026	326.78	272.95	285.02	189.49	239.89	179.81
		500	-0.024	361.46	301.94	315.29	209.63	265.38	198.93
		550	-0.021	396.14	330.93	345.56	229.77	290.87	218.04
		600	-0.020	430.84	359.93	375.84	249.92	316.37	237.16
		650	-0.018	465.53	388.93	406.12	270.06	341.86	256.28
		700	-0.017	500.21	417.91	436.38	290.20	367.34	275.39
		750	-0.016	534.90	446.91	466.66	310.34	392.83	294.51
		800	-0.015	569.58	475.90	496.92	330.48	418.32	313.62
		850	-0.014	604.29	504.91	527.21	350.63	443.82	332.74
		900	-0.013	638.94	533.87	557.45	370.75	469.29	351.84
	950	-0.013	673.61	562.85	587.71	390.89	494.76	370.94	
	1000	-0.012	708.32	591.86	618.00	411.04	520.27	390.07	

Distribution Partner:



SCORPION VISION