

MVL-KF3528M-12MP

1.1" 35mm 12MP FA LENS

KF series FA Lens are optimized for machine vision light sources and sensors, with high resolution, excellent image uniformity, high transmittance and good stability. Featured with fixed focal length, manual aperture and compact size, it is suitable for machine vision industry applications.



Key Features

- High resolution, high definition of the whole image
- Low distortion, high illumination relative
- Excellent mechanism design, improve the shock resistance and high/low temperature stability
- Multilayer wide band coating, ensuring high transmittance of visible and near infrared light
- Support ultra short working distance, maintaining excellent optical properties at different object distances

Distortion

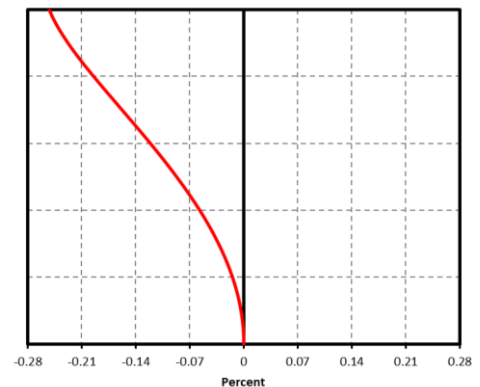

Relative Illumination

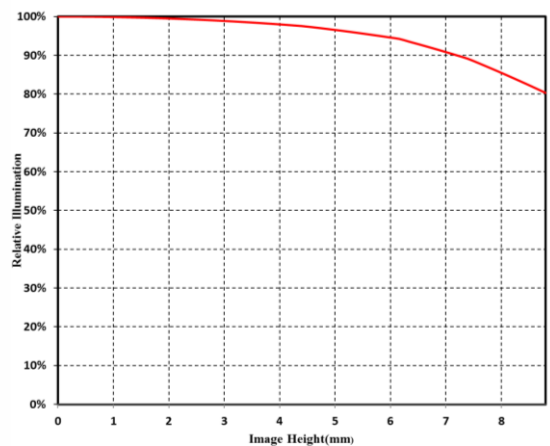

MTF

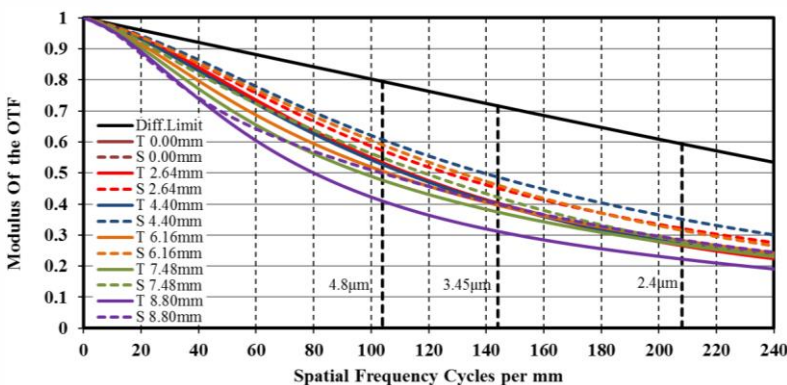

Note: The above curves are the simulate results based on F2.8, $\beta=-0.099$, WD=350 mm.



Specification

Model	MVL-KF3528M-12MP
Parameter	Fixed focal length, Manual iris, 12MP, FA Lens
Performance	
Focal Length	35 mm
F-Number	F2.8 ~ F16
Image Size	Φ17.6 mm(1.1")
Optical Distortion	-0.21%
Minimum Operation Distance	0.2 m
Field of View	D (17.52mm) : 26.7° H (14.14mm) : 21.4° V (10.35mm) : 15.9°
Mechanical	
Iris Control	Manual
Focus Control	Manual
Filter Thread	M35.5*0.5
Mount	C-Mount
Flange Back Length	17.526 mm
Dimension	Φ39×53.61 mm
Weight	119 g
Temperature	-10 ~ 50°C
General	
Certification	RoHS2.0

Dimension

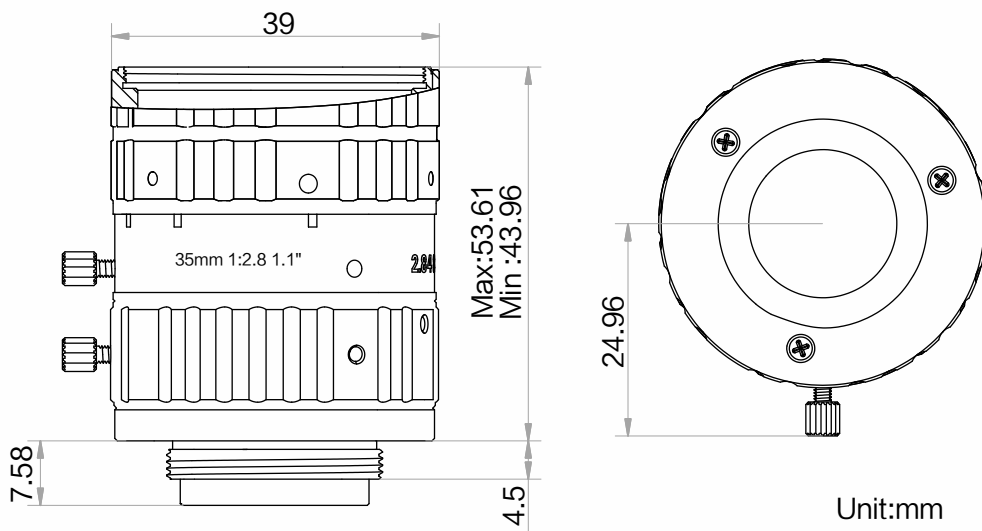

Field of View

Extension (mm)	Working Distance (mm)	Magnification	Field of View (mm)					
			1.1"		1"		2/3"	
			H(14.14mm)	V(10.35mm)	H(12.45mm)	V(9.83mm)	H(8.45mm)	V(7.07mm)
38	25	-1.217	11.62	8.51	10.23	8.08	6.94	5.81
18	50	-0.654	21.61	15.82	19.03	15.02	12.91	10.80
10	75	-0.451	31.35	22.95	27.61	21.80	18.74	15.68
6	100	-0.343	41.18	30.14	36.26	28.63	24.61	20.59
2	150	-0.232	60.91	44.58	53.63	42.34	36.40	30.45
0	200	-0.175	80.67	59.05	71.03	56.08	48.21	40.33
	250	-0.139	101.51	74.30	89.38	70.57	60.66	50.76
	300	-0.116	122.36	89.57	107.74	85.06	73.12	61.18
	350	-0.099	143.21	104.83	126.10	99.56	85.58	71.61
	400	-0.086	164.06	120.09	144.45	114.05	98.04	82.03
	450	-0.077	184.91	135.35	162.81	128.55	110.50	92.46
	500	-0.069	205.76	150.61	181.17	143.04	122.96	102.89
	550	-0.062	226.62	165.88	199.53	157.54	135.43	113.31
	600	-0.057	247.47	181.14	217.89	172.03	147.89	123.74
	650	-0.053	268.32	196.40	236.25	186.53	160.35	134.16
	700	-0.049	289.17	211.66	254.61	201.02	172.81	144.59
	750	-0.046	310.02	226.93	272.97	215.52	185.27	155.02
	800	-0.043	330.88	242.19	291.33	230.01	197.73	165.44
	850	-0.040	351.73	257.45	309.69	244.51	210.19	175.87
	900	-0.038	372.58	272.71	328.05	259.01	222.65	186.29
950	-0.036	393.43	287.98	346.41	273.50	235.11	196.72	
1000	-0.034	414.28	303.24	364.77	288.00	247.58	207.15	

Distribution Partner:



**SCORPION
VISION**