



MVL-KF2528M-12MPE

1.1" 25mm 12MP FA LENS

KF-E series FA Lens are optimized for machine vision light sources and sensor, with high resolution, excellent image quality, high transmittance and good stability. Featured with fixed focal length, manual aperture and compact size, it is suitable for machine vision industry applications and ideal for industrial cameras.



Key Features

- Ultra high resolution and consistency of image clarity
- Lower distortion
- Super high image peripheral brightness ratio
- Excellent optical properties are maintained at different object distances

Distortion

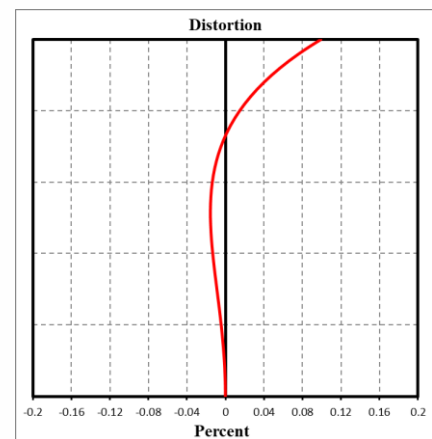

MTF

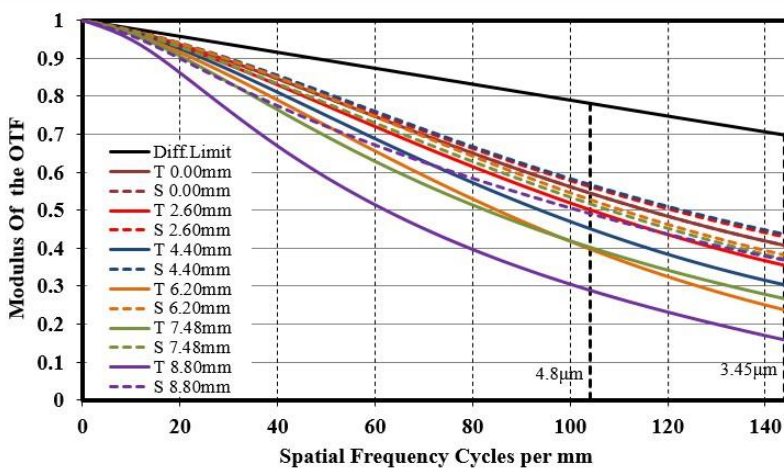

Relative Illumination

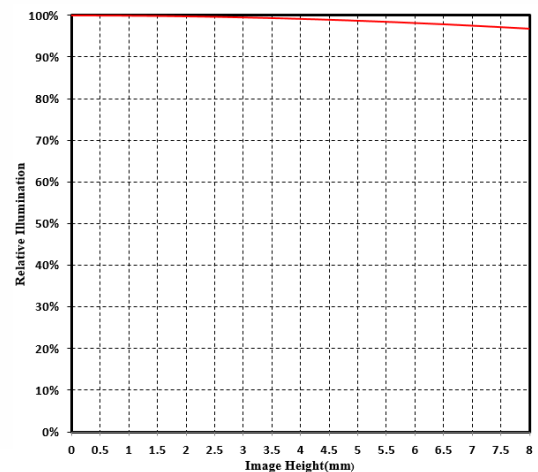

Note: The above curves are the simulate results based on F2.8, $\beta=-0.049$, WD=500 mm.



Specification

Model	MVL-KF2528M-12MPE
Parameter	Fixed focal length, Manual iris, 12MP, FA lens
Performance	
Focal Length	25 mm
F-Number	F2.8 ~ F22
Image Size	Φ17.6 mm(1.1")
Distortion	0.1%
Minimum Operation Distance	0.1 m
Field of View	D (17.52mm) : 37.6° H (14.14mm) : 30.4° V (10.35mm) : 23°
Mechanical	
Iris Control	Manual
Focus Control	Manual
Filter Thread	M35.5 × 0.5
Mount	C-Mount
Flange Back Length	17.526 mm
Dimension	Φ37 × 82 mm
Weight	180 g
Temperature	-10 ~ 50°C
General	
Certification	RoHS2.0

Dimension

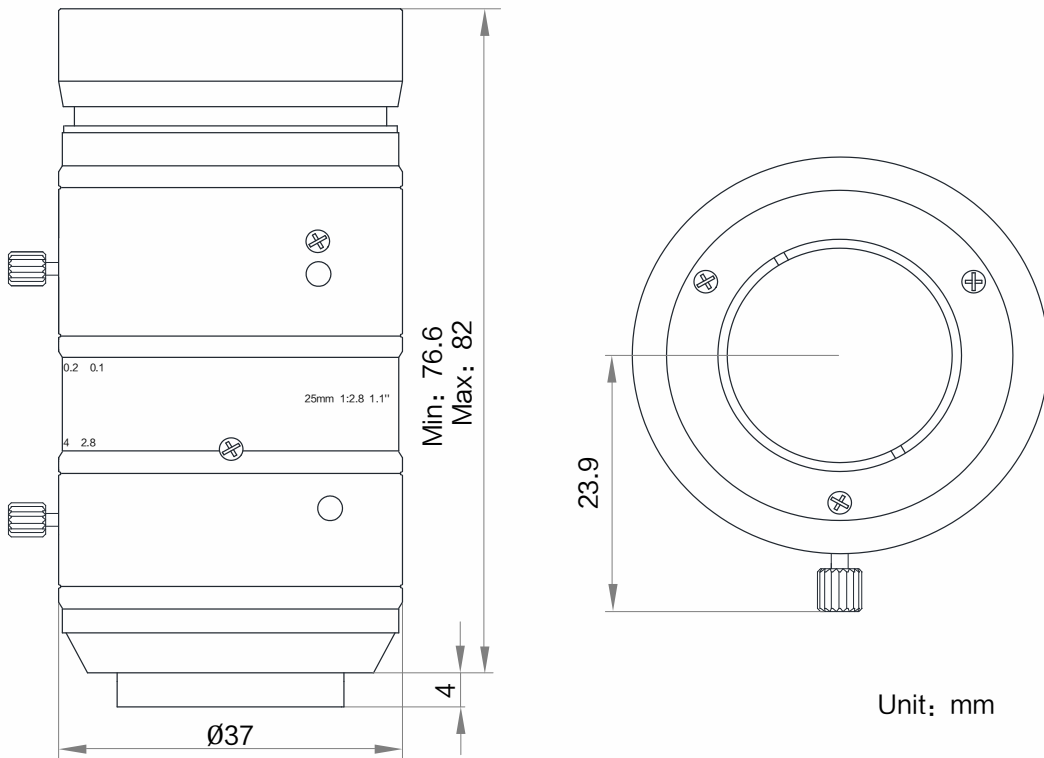

Field of View

Extension (mm)	Working Distance(mm)		Magnification	Field of View(mm)					
				1.1" (14.14mm × 10.35mm)		1" (12.45mm × 9.83mm)		2/3" (8.45mm × 7.07mm)	
				H	V	H	V	H	V
5	near	47.03	-0.415	34.00	24.90	31.00	23.73	21.00	15.75
	far	48.81	-0.400	35.00	25.60	31.00	23.73	21.00	15.75
2	near	70.02	-0.300	47.00	34.42	43.00	32.92	30.00	22.50
	far	73.56	-0.288	49.00	38.89	45.00	34.45	31.00	23.25
1	near	82.41	-0.260	54.00	39.55	49.00	37.51	34.00	25.50
	far	89.51	-0.240	58.00	42.48	52.00	39.81	36.00	27.00
0		100	-0.223	63.41	46.41	55.83	44.08	37.89	31.70
		150	-0.154	92.00	67.34	80.84	63.83	54.87	45.91
		200	-0.118	120.07	87.89	105.51	83.31	71.61	59.92
		250	-0.096	147.59	108.03	129.69	102.40	88.02	73.65
		300	-0.080	177.10	129.63	155.63	122.88	105.63	88.38
		350	-0.069	205.34	150.30	180.43	142.46	122.46	102.46
		400	-0.061	232.27	170.01	204.10	161.15	138.52	115.90
		450	-0.054	262.38	192.05	230.56	182.04	156.48	130.93
		500	-0.049	289.15	211.65	254.08	200.61	172.45	144.29
		550	-0.045	314.85	230.46	276.67	218.44	187.78	157.11
		600	-0.041	343.06	251.11	301.45	238.01	204.60	171.19
		650	-0.038	370.90	271.48	325.92	257.33	221.20	185.08
		700	-0.036	399.11	292.13	350.70	276.90	238.03	199.15
		800	-0.031	454.11	332.39	399.04	315.06	270.83	226.60
		900	-0.027	524.75	384.10	461.11	364.07	312.96	261.85
	1000	-0.025	566.73	414.83	498.00	393.20	338.00	282.80	

Distribution Partner:



SCORPION VISION