

## MVL-KF1228M-12MPE 1.1" 12mm 12MP FA LENS

KF-E series FA Lens are optimized for machine vision light sources and sensor, with high resolution, excellent image quality, high transmittance and good stability. Featured with fixed focal length, manual aperture and compact size, it is suitable for machine vision industry applications and ideal for industrial cameras.



### Key Features

- Ultra high resolution and consistency of image clarity
- Lower distortion
- Super high image peripheral brightness ratio
- Excellent optical properties are maintained at different object distances

### Distortion

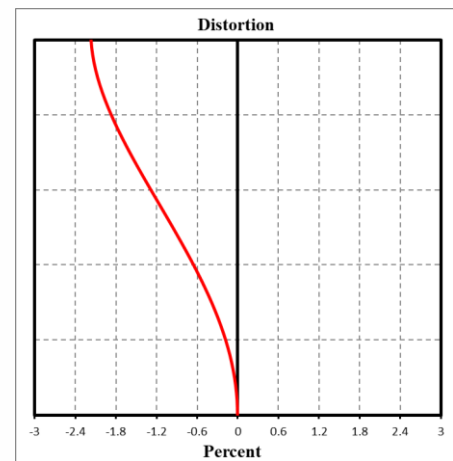

### MTF

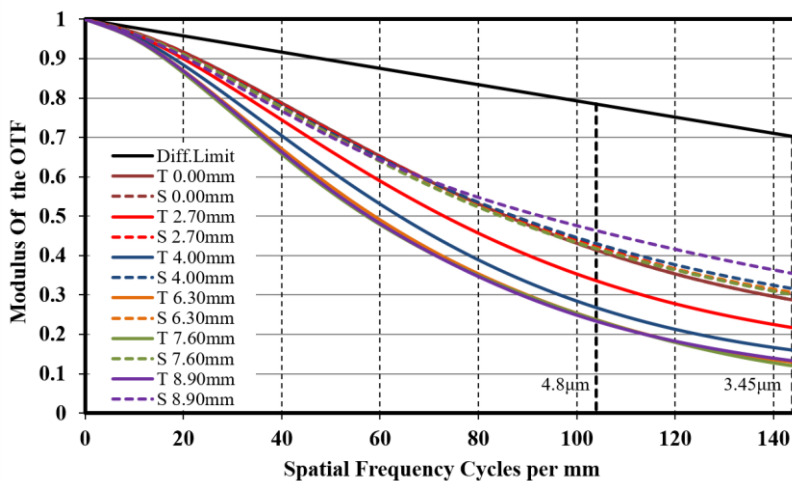

### Relative Illumination

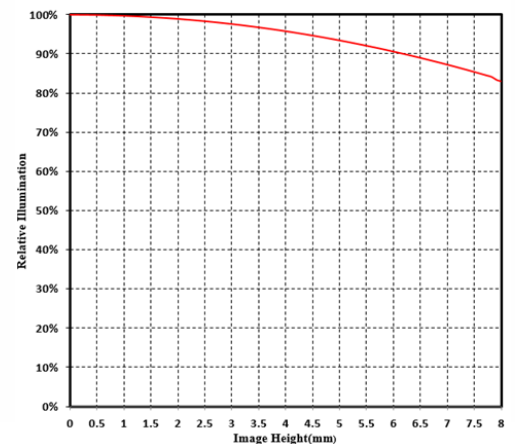

Note: The above curves are the simulate results based on F2.8,  $\beta = -0.024$ , WD=500 mm.



## Specification

|                            |   |                   |
|----------------------------|---|-------------------|
|                            | Model   | MVL-KF1228M-12MPE |
| Parameter                  | Fixed focal length, Manual iris, 12MP, FA lens                |                   |
| <b>Performance</b>         |   |                   |
| Focal Length               | 12 mm   |                   |
| F-Number                   | F2.8 ~ F22  |                   |
| Image Size                 | Φ17.6 mm(1.1")  |                   |
| Distortion                 | 1.5%  |                   |
| Minimum Operation Distance | 0.1 m   |                   |
| Field of View              | D (17.52mm) : 66.7°<br>H (14.14mm) : 57°<br>V (10.35mm) : 45° |                   |
| <b>Mechanical</b>          |   |                   |
| Iris Control               | Manual  |                   |
| Focus Control              | Manual  |                   |
| Mount                      | C-Mount   |                   |
| Flange Back Length         | 17.526 mm   |                   |
| Dimension                  | Φ48 × 71.32 mm  |                   |
| Weight                     | 245 g   |                   |
| Temperature                | -10 ~ 50°C  |                   |
| <b>General</b>             |   |                   |
| Certification              | RoHS2.0   |                   |

## Dimension

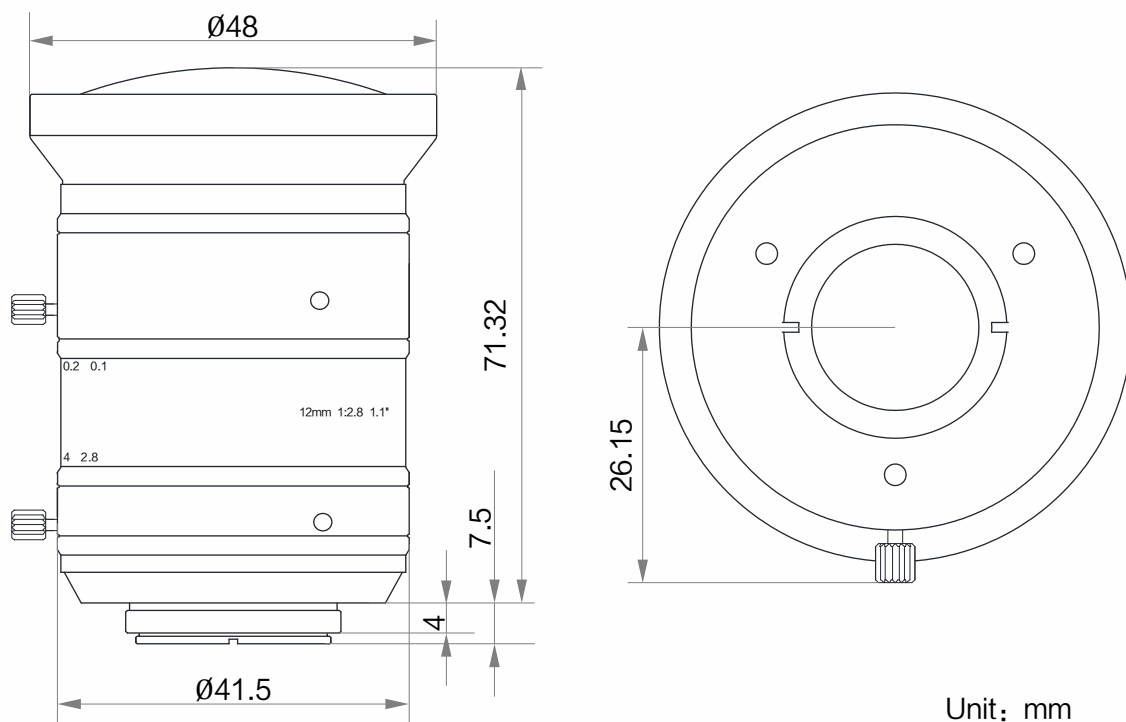

## Field of View

| Extension<br>(mm) | Working<br>Distance(mm) |        | Magnification | Field of View(mm)           |         |                          |        |                           |        |
|-------------------|-------------------------|--------|---------------|-----------------------------|---------|--------------------------|--------|---------------------------|--------|
|                   |                         |        |               | 1.1"<br>(14.14mm × 10.35mm) |         | 1"<br>(12.45mm × 9.83mm) |        | 2/3"<br>(8.45mm × 7.07mm) |        |
|                   |                         |        |               | H                           | V       | H                        | V      | H                         | V      |
| 5                 | near                    | 6.42   | -0.523        | 27.00                       | 19.70   | 25.00                    | 19.00  | 17.00                     | 12.75  |
|                   | far                     | 8.12   | -0.487        | 29.00                       | 21.20   | 26.00                    | 19.90  | 18.00                     | 13.50  |
| 2                 | near                    | 27.65  | -0.272        | 52.00                       | 38.10   | 47.00                    | 35.98  | 33.00                     | 24.75  |
|                   | far                     | 34.45  | -0.236        | 60.00                       | 43.94   | 55.00                    | 42.10  | 37.00                     | 27.75  |
| 1                 | near                    | 47.19  | -0.188        | 75.00                       | 54.93   | 68.00                    | 52.00  | 47.00                     | 35.25  |
|                   | far                     | 63.34  | -0.150        | 94.00                       | 68.84   | 85.00                    | 65.00  | 59.00                     | 44.25  |
| 0                 | 100                     |        | -0.100        | 144.95                      | 106.1   | 127.63                   | 100.77 | 86.62                     | 72.48  |
|                   | 150                     |        | -0.071        | 198.44                      | 145.25  | 174.37                   | 137.68 | 118.35                    | 99.02  |
|                   | 200                     |        | -0.057        | 250.77                      | 183.55  | 220.35                   | 173.98 | 149.56                    | 125.13 |
|                   | 250                     |        | -0.045        | 312.08                      | 228.43  | 274.23                   | 216.52 | 186.12                    | 155.73 |
|                   | 300                     |        | -0.039        | 364.22                      | 266.60  | 320.05                   | 252.70 | 217.22                    | 181.75 |
|                   | 350                     |        | -0.033        | 425.47                      | 311.43  | 373.87                   | 295.20 | 253.75                    | 212.31 |
|                   | 400                     |        | -0.029        | 481.91                      | 352.74  | 423.47                   | 334.35 | 287.41                    | 240.48 |
|                   | 450                     |        | -0.026        | 538.72                      | 394.32  | 473.38                   | 373.76 | 321.29                    | 268.82 |
|                   | 500                     |        | -0.024        | 595.31                      | 435.74  | 523.11                   | 413.03 | 355.04                    | 297.06 |
|                   | 550                     |        | -0.021        | 652.92                      | 477.91  | 573.73                   | 453.00 | 389.40                    | 325.81 |
|                   | 600                     |        | -0.020        | 711.97                      | 521.14  | 625.63                   | 493.97 | 424.62                    | 355.28 |
|                   | 650                     |        | -0.019        | 765.85                      | 560.58  | 672.97                   | 531.35 | 456.76                    | 382.16 |
|                   | 700                     |        | -0.017        | 823.74                      | 602.95  | 723.84                   | 571.51 | 491.28                    | 411.05 |
|                   | 800                     |        | -0.015        | 938.30                      | 686.80  | 824.50                   | 650.99 | 559.60                    | 468.21 |
| 900               |                         | -0.014 | 1049.50       | 768.20                      | 922.22  | 728.15                   | 625.93 | 523.70                    |        |
| 1000              |                         | -0.012 | 1151.89       | 843.15                      | 1012.20 | 799.19                   | 686.99 | 574.80                    |        |

Distribution Partner:



# SCORPION VISION