

MVL-KF0818M-12MP 1" 8mm 12MP FA LENS

FA series Lens are optimized for machine vision light sources and sensors, with high resolution, excellent image uniformity, high transmittance and good stability. Featured with fixed focal length, manual aperture and compact size, it is suitable for machine vision industry applications.



Key Features

- High resolution, high definition of the whole image
- Low distortion, high illumination relative
- Excellent mechanism design, improve the shock resistance and high/low temperature stability
- Multilayer wide band coating, ensuring high transmittance of visible and near infrared light
- Support ultra short working distance, maintaining excellent optical properties at different object distances

Order Model

MVL-KF0818M-12MP

Specification

Parameter		Model	
		MVL-KF0818M-12MP	
		Fixed focal length, Manual iris, 12MP, FA Lens	
Focal Length	8mm	Mount	C-Mount
F-Number	F1.8~C	Flange Back Length	17.526mm
Image Size	Φ16mm(1")	Filter Thread	/
Optical Distortion	-4.12%	Minimum Operation Distance	0.3m
Control	Iris	Manual	Dimension Φ56.8×54.9mm
	Focus	Manual	
Operating Temperature	-10~50°C	Weight	236g
Angle of View	1"	D	90.06°
		H	77.16°
		V	61.3°



Field of View

Working Distance (mm)	Magnification	Extension (mm)	Field of View (mm)			
			1" (12.45mm×9.83mm)		2/3" (8.45mm×7.07mm)	
			H	V	H	V
25	0.179	1	78.38	59.23	49.94	41.11
50	0.116	0.5	118.07	90.20	76.37	63.06
75	0.086	0.5	156.34	120.19	102.00	84.37
100	0.069	0.5	194.52	150.11	127.58	105.64
150	0.048		275.49	213.32	181.56	150.51
200	0.037		353.11	274.12	233.53	193.73
250	0.031		430.70	334.89	285.48	236.93
300	0.026		508.28	395.65	337.41	280.13
350	0.022		585.84	456.41	389.35	323.32
400	0.020		663.40	517.16	441.28	366.51
450	0.018		740.96	579.91	493.20	409.70
500	0.016		818.51	638.66	545.13	452.88
550	0.015		896.07	699.40	597.05	496.07
600	0.013		973.61	760.15	648.98	539.25
700	0.012		1128.71	881.63	752.82	625.62
800	0.010		1283.80	1003.11	856.66	711.98
900	0.009		1438.89	1124.59	960.50	798.35
1000	0.008		1593.97	1246.07	1064.34	884.71

Dimension

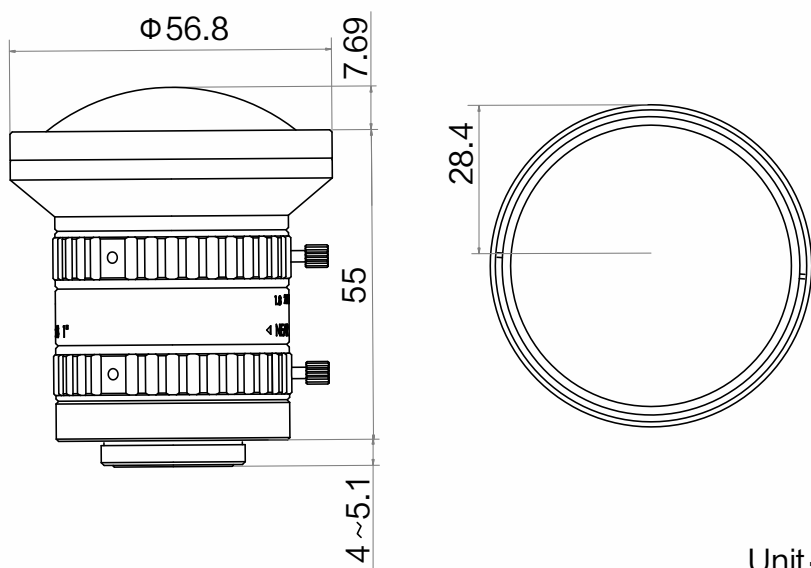

Unit: mm

MTF

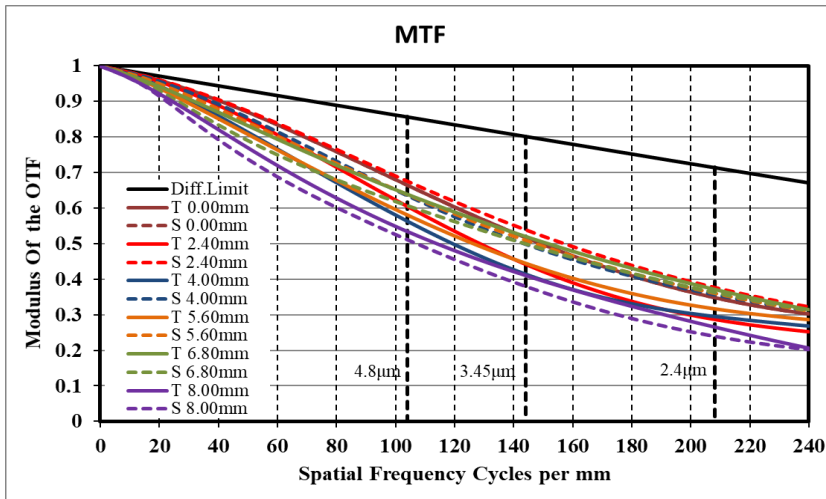

Distortion

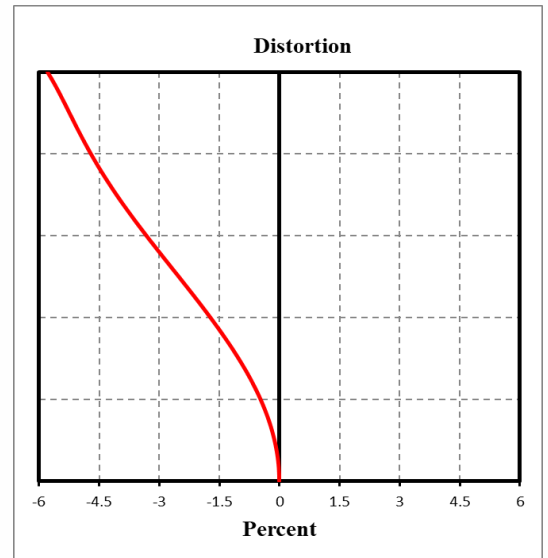

Transmission

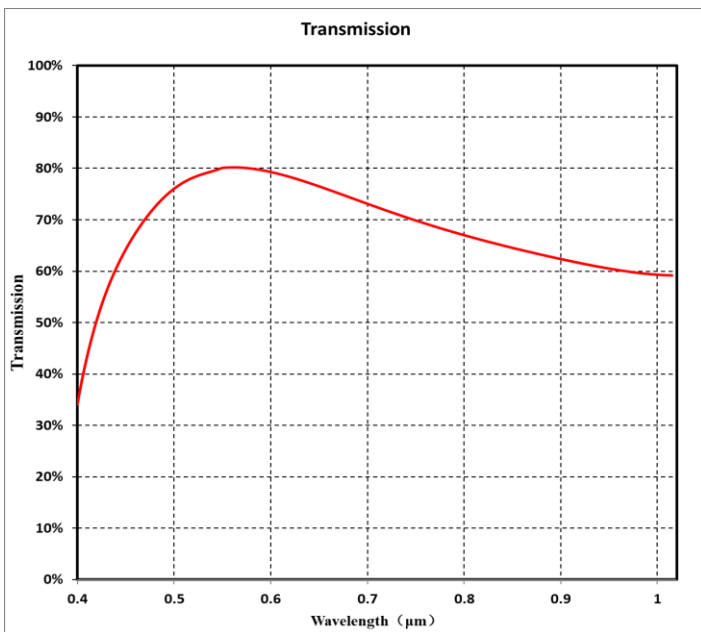

Relative Illumination

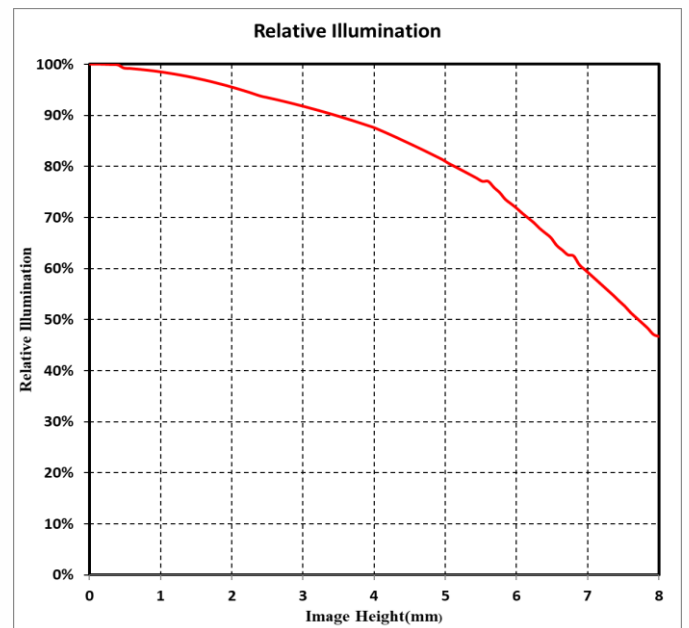

Note: The above curves are the simulate results based on F1.8, $\beta=-0.016$, WD=500 mm.



SCORPION
VISION LIMITED

www.scorpionvision.co.uk +44 (0)1590 679333
sales@scorpion.vision