

MVL-KF0814M-12MPE 1.1" 8mm 12MP FA LENS

KF-E series FA Lens are optimized for machine vision light sources and sensor, with high resolution, excellent image quality, high transmittance and good stability. Featured with fixed focal length, manual aperture and compact size, it is suitable for machine vision industry applications and ideal for industrial cameras.



Key Features

- Ultra high resolution and consistency of image clarity
- Lower distortion
- Super high image peripheral brightness ratio
- Excellent optical properties are maintained at different object distances

Distortion

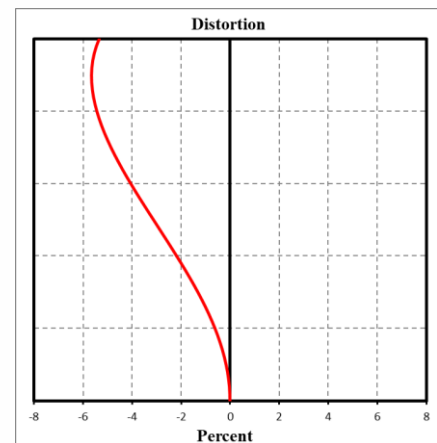

MTF

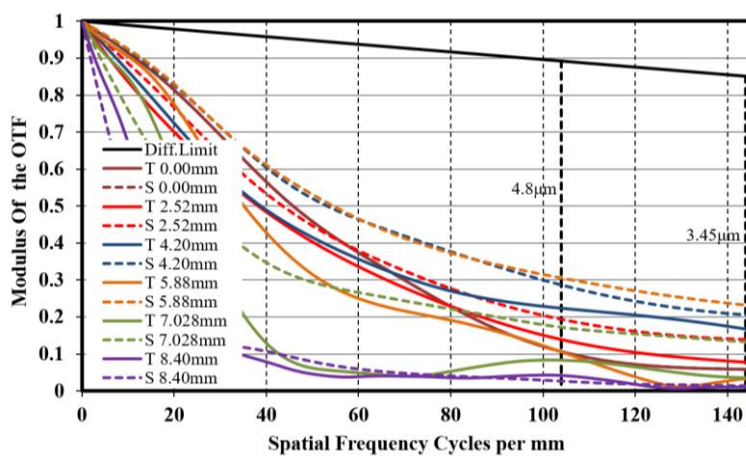

Relative Illumination

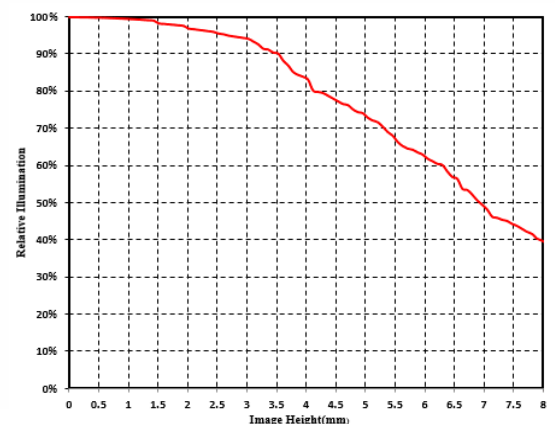

Note: The above curves are the simulate results based on F1.4, $\beta = -0.016$, WD=500 mm.



Specification

Model	MVL- KF0814M -12MPE
Parameter	Fixed focal length, Manual iris, 12MP, FA lens
Performance	
Focal Length	8 mm
F-Number	F1.4 ~ F16
Image Size	Φ17.6 mm(1.1")
Distortion	5.5%
Minimum Operation Distance	0.1 m
Field of View	D (17.52mm) : 98.4° H (14.14mm) : 84.8° V (10.35mm) : 68°
Mechanical	
Iris Control	Manual
Focus Control	Manual
Filter Thread	M58×0.75
Mount	C-Mount
Flange Back Length	17.526 mm
Dimension	Φ60×77.8 mm
Weight	371 g
Temperature	-10 ~ 50°C
General	
Certification	RoHS2.0

Dimension

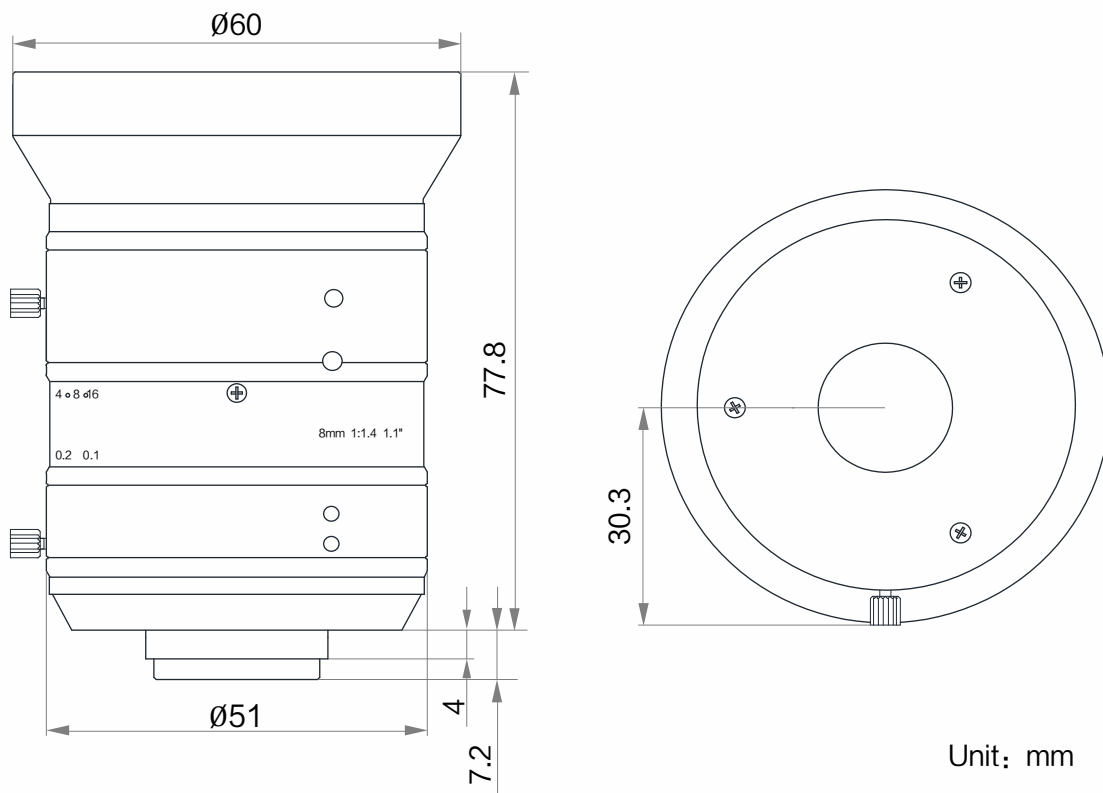

Field of View

Extension (mm)	Working Distance (mm)		Magnification	Field of View (mm)					
				1.1" (14.14mm×10.35mm)		1" (12.45mm×9.83mm)		2/3" (8.45mm×7.07mm)	
				H	V	H	V	H	V
1	near	16.32	-0.193	73.00	53.47	66.00	50.53	46.00	34.50
	far	35.02	-0.133	106.00	77.63	96.00	73.50	66.00	49.50
0	100		-0.064	220.08	161.09	193.93	153.12	131.62	110.12
	150		-0.046	305.62	223.71	269.10	212.47	182.64	152.81
	200		-0.036	391.47	286.54	344.68	272.15	233.94	195.74
	250		-0.030	477.70	349.66	420.61	332.09	285.47	238.85
	300		-0.025	563.35	412.35	496.02	391.63	336.65	281.67
	350		-0.022	649.52	475.42	571.89	451.54	388.15	324.76
	400		-0.019	736.46	539.06	648.44	511.98	440.10	368.23
	450		-0.017	822.09	601.74	723.84	571.51	491.28	411.05
	500		-0.016	912.26	667.74	803.23	634.19	545.16	456.13
	550		-0.014	995.77	728.87	876.76	692.25	595.07	497.89
	600		-0.013	1087.69	796.15	957.69	756.15	650.00	543.85
	650		-0.012	1168.60	855.37	1028.93	812.40	698.35	584.30
	700		-0.011	1262.50	924.11	1111.61	877.68	754.46	631.25
	800		-0.010	1428.28	1045.45	1257.58	992.93	853.54	714.14
	900		-0.009	1606.82	1176.14	1414.77	1117.05	960.23	803.41
1000		-0.008	1789.87	1310.13	1575.95	1244.30	1069.62	894.94	

Distribution Partner:



**SCORPION
VISION**