



MVL-HF5028M-6MPE 1/1.8" 50mm 6MP FA LENS

HF-E series FA Lens are optimized for machine vision light sources and sensor, with high resolution, excellent image quality, high transmittance and good stability. Featured with fixed focal length, manual aperture and compact size, it is suitable for machine vision industry applications and ideal for industrial cameras.



Key Features

- Higher image clarity and contrast ratio
- Ultra-low distortion and higher relative illumination rate
- Good optical performance at ultra-short working distance
- Compact design, convenient for device integration

Distortion

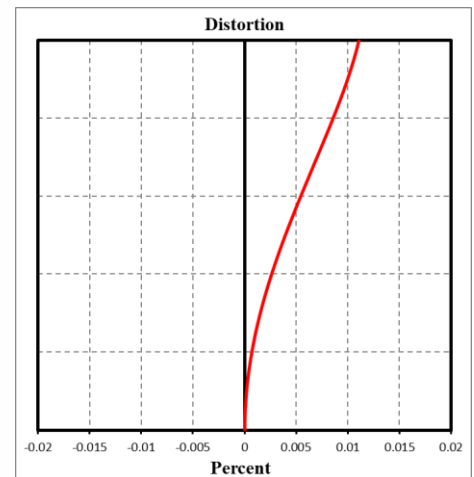

MTF:

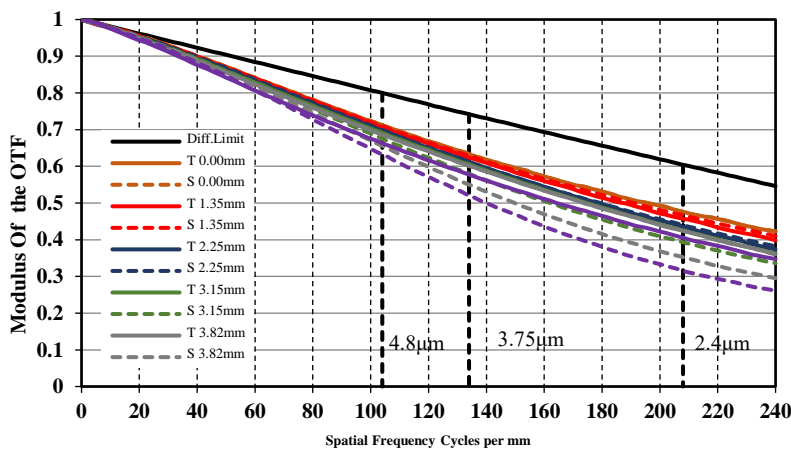

Relative Illumination

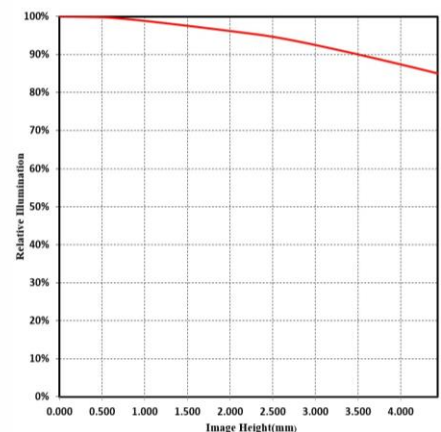

Note: The above curves are the simulate results based on F2.8, $\beta=-0.105$, WD=500 mm.



Specification

	Model	MVL-HF5028M-6MPE
Parameter	Fixed focal length, Manual iris, 6MP, FA Lens	
Performance		
Focal Length	50 mm	
F-Number	F2.8~F16	
Image Size	Φ9 mm(1/1.8'')	
Distortion	0.03%	
Minimum Operation Distance	0.25 m	
Field of View	D (8.96mm) : 9.72° H (7.38mm) : 7.84° V (4.92mm) : 5.24°	
Mechanical		
Iris Control	Manual	
Focus Control	Manual	
Filter Thread	M30.5×0.5	
Mount	C-Mount	
Flange Back Length	17.526 mm	
Dimension	Φ37×51.7 mm	
Weight	102 g	
Temperature	-10 ~ 50℃	
General		
Certification	RoHS2.0	

Dimension

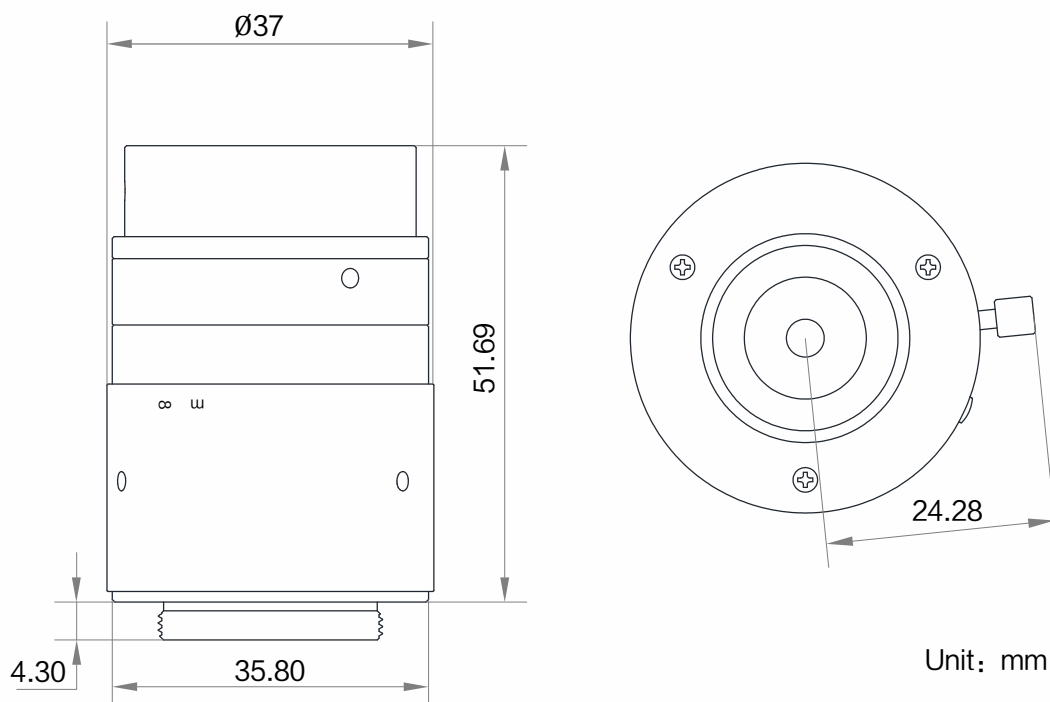

Field of View

Extension (mm)	Working Distance (mm)		Magnification	Field of View (mm)			
				1/1.8"		1/2"	
				H(7.38mm)	H(4.92mm)	H(6.22mm)	V(4.67mm)
20	near	108.6	-0.645	11.47	7.64	9.67	7.25
	far	146.7	-0.427	17.33	11.54	14.60	10.95
10	near	144.4	-0.433	17.08	11.38	14.39	10.80
	far	247.9	-0.231	31.94	21.28	26.91	20.20
5	near	179.9	-0.327	22.63	15.08	19.07	14.31
	far	410.9	-0.133	55.44	36.96	46.73	35.08
2	near	215.1	-0.263	28.12	18.74	23.69	17.78
	far	717.1	-0.074	99.55	66.39	83.92	63.02
1	near	231.0	-0.242	30.60	20.39	25.78	19.35
	far	967.3	-0.054	135.59	90.43	114.30	85.84
0		250	-0.220	33.56	22.37	28.28	21.23
		300	-0.180	40.98	27.31	34.53	25.92
		350	-0.153	48.31	32.20	40.71	30.56
		400	-0.133	55.57	37.04	46.83	35.16
		450	-0.118	62.80	41.86	52.93	39.74
		500	-0.105	70.00	46.67	59.00	44.30
		550	-0.096	77.18	51.46	65.05	48.84
		600	-0.087	84.34	56.23	71.09	53.38
		650	-0.081	91.49	61.01	77.12	57.91
		700	-0.075	98.63	65.77	83.14	62.43
		800	-0.065	112.88	75.28	95.16	71.46
		900	-0.058	127.12	84.78	107.16	80.47
	1000	-0.052	141.34	94.27	119.15	89.48	

Distribution Partner:



**SCORPION
VISION**