

MVL-HF0828M-6MPE 1/1.8" 8mm 6MP FA LENS

HF-E series FA Lens are optimized for machine vision light sources and sensor, with high resolution, excellent image quality, high transmittance and good stability. Featured with fixed focal length, manual aperture and compact size, it is suitable for machine vision industry applications and ideal for industrial cameras.



Key Features

- Higher image clarity and contrast ratio
- Ultra-low distortion and higher relative illumination rate
- Good optical performance at ultra-short working distance
- Compact design, convenient for device integration

Distortion

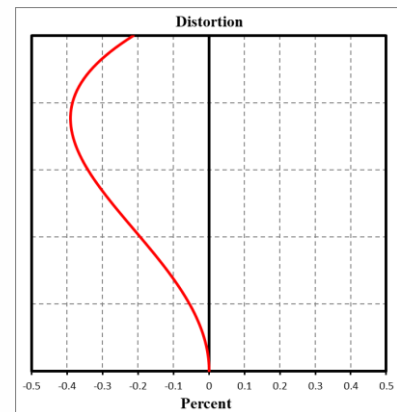

MTF

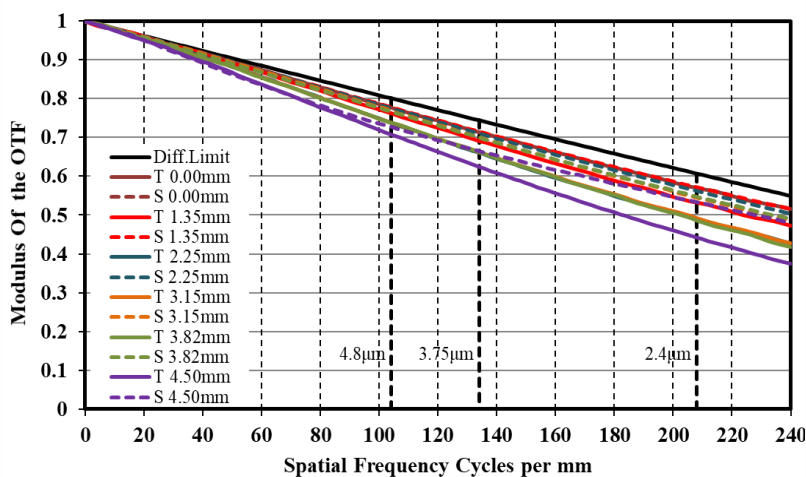

Relative Illumination

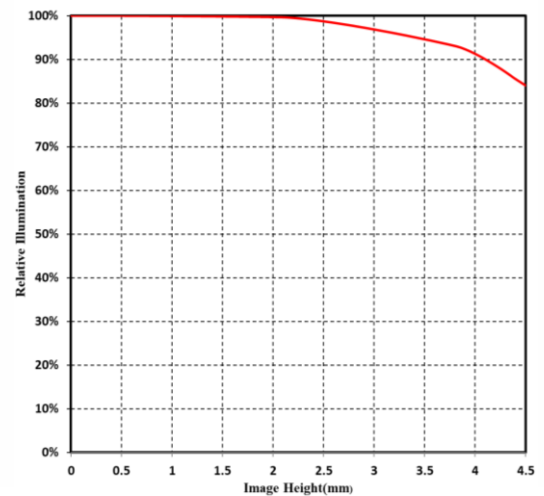

Note: The above curves are the simulate results based on F2.8, $\beta = -0.026$, WD=300 mm.



Specification

Model	MVL-HF0828M-6MPE
Parameter	Fixed focal length, Manual iris, 6MP, FA Lens
Performance	
Focal Length	8 mm
F-Number	F2.8 ~ F16
Image Size	Φ9 mm(1/1.8'')
Distortion	0.049%
Minimum Operation Distance	0.1 m
Field of View	D (8.96mm) : 58.50° H (7.38mm) : 49.46° V (4.92mm) : 34.19°
Mechanical	
Iris Control	Manual
Focus Control	Manual
Filter Thread	M37.5×P0.5
Mount	C-Mount
Flange Back Length	17.526 mm
Dimension	Φ33×34.5 mm
Weight	63.3 g
Temperature	-10 ~ 50°C
General	
Certification	RoHS2.0

Dimension

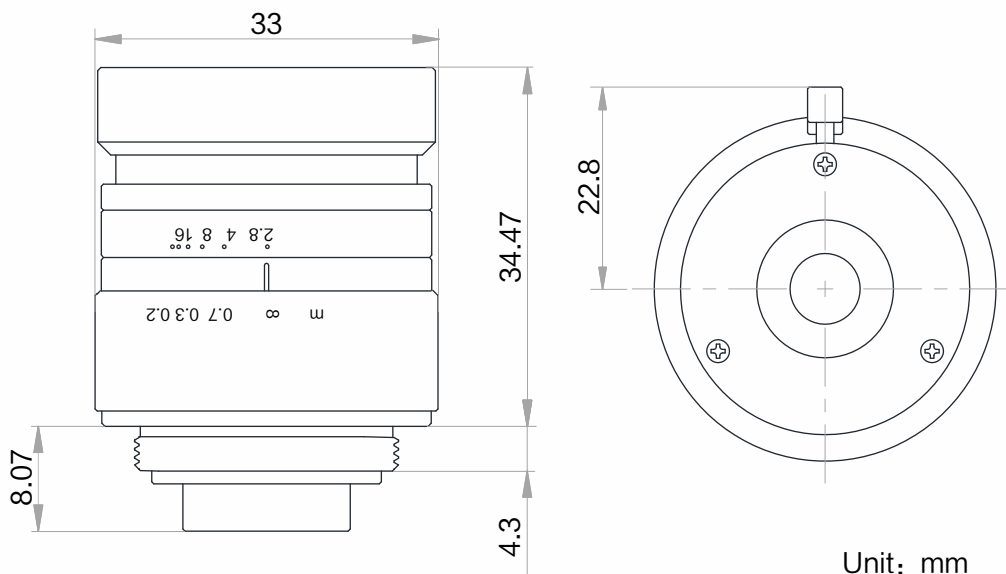

Field of View

Extension(mm)	Working Distance(mm)		Magnification	Field of View(mm)			
				1/1.8"		1/2"	
				H(7.38mm)	V(9.42mm)	H(6.22mm)	V(4.67mm)
1	near	27.54	-0.195	39.22	25.67	32.74	24.33
	far	52.6	-0.123	61.57	40.56	51.58	38.46
0		100	-0.071	104.96	69.56	88.21	65.98
		150	-0.050	149.83	99.54	126.10	94.45
		200	-0.038	194.66	129.50	163.95	122.88
		250	-0.031	239.47	159.45	201.79	151.31
		300	-0.026	284.27	189.40	239.61	179.74
		350	-0.023	329.07	219.34	277.44	208.16
		400	-0.020	373.86	249.28	315.26	236.58
		450	-0.018	418.64	279.22	353.08	265.00
		500	-0.016	463.43	309.16	390.90	293.42
		550	-0.015	508.21	339.09	428.71	321.83
		600	-0.013	552.99	369.03	466.53	350.25
		650	-0.012	597.77	398.97	504.34	378.67
		700	-0.012	642.56	428.90	542.16	407.08
		800	-0.010	732.12	488.77	617.79	463.91
	900	-0.009	821.67	548.64	693.42	520.74	
	1000	-0.008	911.23	608.51	769.04	577.57	

Distribution Partner:



SCORPION VISION