

H0514-MP2

f=5mm F1.4
for 1/2 type Megapixel Cameras
C-Mount

Model No.		H0514-MP2		Effective	Front	φ 27.8mm	
Focal Length		5mm		Lens Aperture	Rear	φ 14.8mm	
Max. Aperture Ratio		1:1.4		Distortion	1/2type	-0.48%(y=4.0)	
Max. Image Format		6.4mm x 4.8mm(φ 8mm)			1/3type	-2.26%(y=3.0)	
Operation Range	Iris	F1.4 - 16C		Back Focal Length		10.8mm	
	Focus	0.1m - 0.9m		Flange Back Length		17.526mm	
Control	Iris	Manual		Mount		C-Mount	
	Focus	Manual		Filter Size		M43 P=0.75mm	
Object Dimension at M.O.D	1/2type	15.0cm x 11.1cm		Dimensions		φ 44.5mm x 45.5mm	
	1/3type	11.1cm x 8.3cm		Weight		102g	
Angle of View	D	1/2 type	76.7°	1/3 type	62.3°		
	H		65.5°		51.4°		
	V		51.4°		39.5°		
Operating Temperature		-10°C - +50°C					

M.O.D : Minimum Object Distance

Dimensions

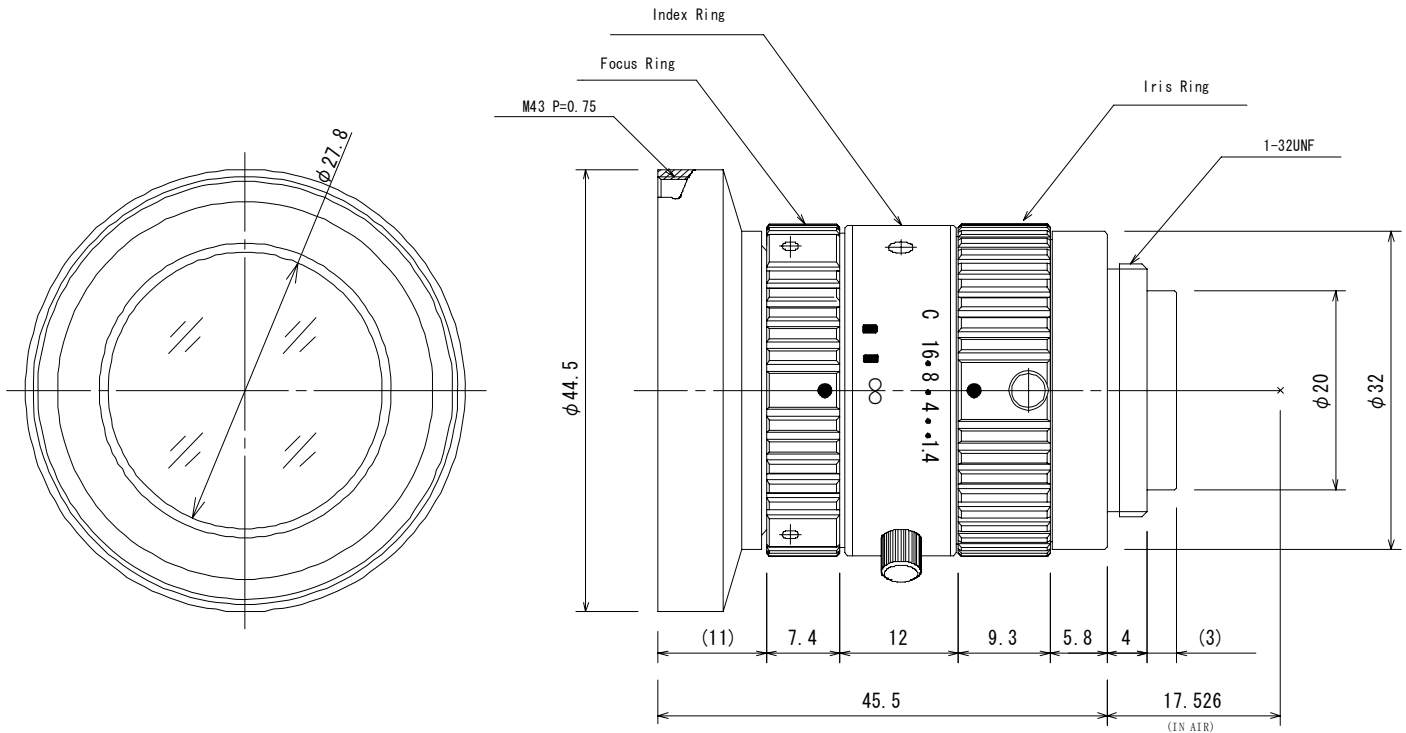

Distribution Partner:



SCORPION VISION

shop.scorpion.vision +44 (0) 1590 679333 sales@scorpion.vision