



Technical Details



# DMK 37BUX178 Technical Reference Manual



<b>1. Quick Facts</b>	<b>4</b>
<b>2. Dimensional Diagrams</b>	<b>6</b>
2.1 DMK 37BUX178 C-Mount with Tripod Adapter .....	6
2.2 DMK 37BUX178 C-Mount without Tripod Adapter .....	7
2.3 DMK 37BUX178 CS-Mount with Tripod Adapter .....	8
2.4 DMK 37BUX178 CS-Mount without Tripod Adapter .....	9
<b>3. I/O Connector</b>	<b>10</b>
3.1 4-pin I/O Connector .....	10
3.1.1 TRIGGER_IN .....	10
3.1.2 STROBE_OUT .....	10
<b>4. Spectral Characteristics</b>	<b>12</b>
4.1 Spectral Sensitivity - IMX178LLJ-C .....	12
<b>5. Camera Controls</b>	<b>13</b>
<b>5.1 Sensor Readout Control</b> .....	<b>13</b>
5.1.1 Pixel Format .....	13
5.1.1.1 8-Bit Monochrome .....	13
5.1.1.2 12-Bit Packed Monochrome .....	14
5.1.1.3 16-Bit Monochrome .....	14
5.1.2 Resolution .....	14
5.1.3 Frame Rate .....	15
5.1.4 Partial Scan Offset .....	16
5.1.5 Image Flipping .....	17
<b>5.2 Image Sensor Control</b> .....	<b>17</b>
5.2.1 Exposure Time .....	18
5.2.2 Gain .....	18
5.2.3 Black Level .....	18
<b>5.3 Automatic Exposure and Gain Control</b> .....	<b>19</b>
5.3.1 Auto Exposure .....	19
5.3.2 Auto Gain .....	20
5.3.3 Auto Reference Value .....	20
5.3.4 Highlight Reduction .....	20
5.3.5 Auto Exposure Limits .....	21
5.3.6 Auto Gain Limits .....	21
<b>5.4 Trigger</b> .....	<b>22</b>
5.4.1 Trigger Mode .....	22
5.4.2 Trigger Polarity .....	22
5.4.3 Trigger Operation .....	23
5.4.4 Software Trigger .....	23
5.4.5 Trigger Overlap .....	24



<b>5.5</b>	<b>Trigger Timing Parameters</b> .....	<b>24</b>
5.5.1	Trigger Delay .....	24
<b>5.6</b>	<b>Digital I/O</b> .....	<b>25</b>
5.6.1	General Purpose Input .....	25
5.6.2	General Purpose Output .....	25
<b>5.7</b>	<b>Strobe</b> .....	<b>25</b>
5.7.1	Strobe Enable .....	26
5.7.2	Strobe Polarity .....	26
5.7.3	Strobe Operation .....	26
5.7.4	Strobe Duration .....	27
5.7.5	Strobe Delay .....	27
<b>5.8</b>	<b>Region of Interest for Auto Functions</b> .....	<b>27</b>
5.8.1	Auto Functions ROI Enable .....	28
5.8.2	Auto Functions ROI Preset .....	28
<b>6.</b>	<b>Revision History</b>	<b>29</b>



## 1 Quick Facts

<b>General</b>	
Vision Standard	USB3 Vision
Dynamic Range	12 bit
Resolution	3072x2048
Frame Rate at Full Resolution	60
Pixel Formats	8-Bit Monochrome 12-Bit Packed Monochrome 16-Bit Monochrome

<b>Optical Interface</b>	
IR-Cut filter	No
Sensor Type	Sony IMX178LLJ-C
Shutter Type	Rolling
Sensor Format	1/1.8 inch
Pixel Size	2.4 $\mu\text{m}$
Lens Mount	C/CS

<b>Electrical Interface</b>	
Interface	USB 3.1gen1
Supply voltage	4.75 VDC to 5.25 VDC
Current consumption	approx 320 mA @ 5 VDC
I/O Connector	4-pin connector for trigger and strobe or general purpose input/output

<b>Mechanical Data</b>	
Dimensions	H: 36 mm, W: 36 mm, L: 25 mm
Mass	70 g

<b>Adjustments</b>	
Shutter	20 $\mu\text{s}$ to 60 s
Gain	0 dB to 48 dB



<b>Environmental</b>	
Temperature (operating)	-5 °C to 45 °C
Temperature (storage)	-20 °C to 60 °C
Humidity (operating)	20 % to 80 % (non-condensing)
Humidity (storage)	20 % to 95 % (non-condensing)



# Dimensional Diagrams

## 2 Dimensional Diagrams

### 2.1 DMK 37BUX178 C-Mount with Tripod Adapter

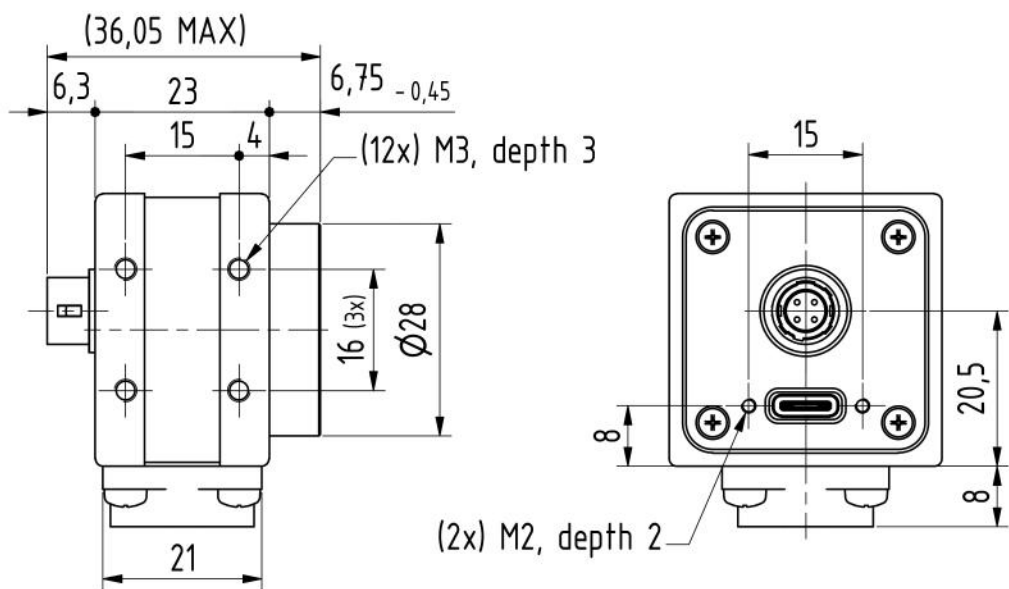
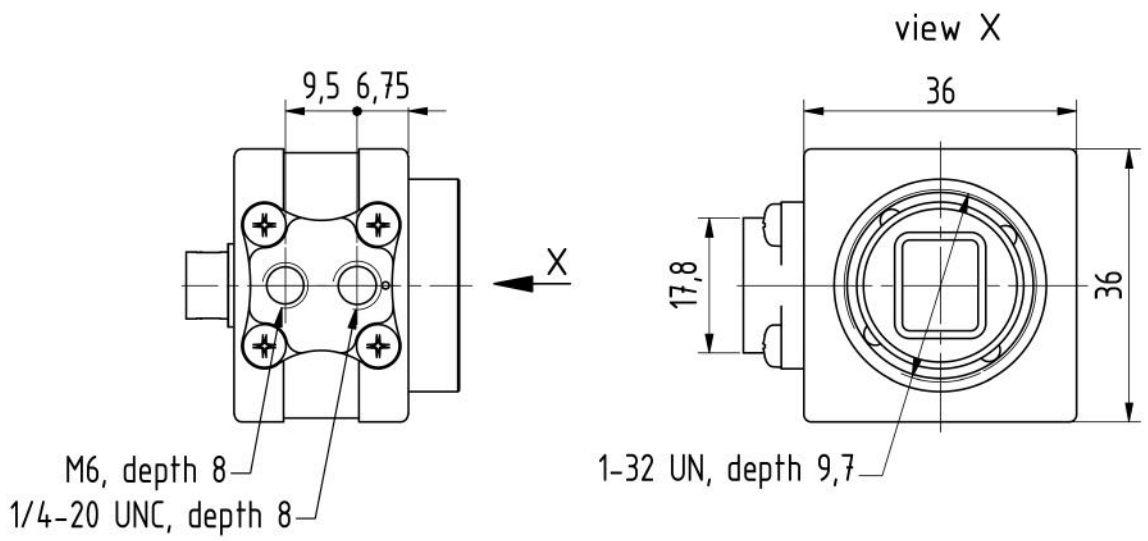

Dimensions: mm  
Tolerances: DIN ISO 2768-f





## 2.2 DMK 37BUX178 C-Mount without Tripod Adapter

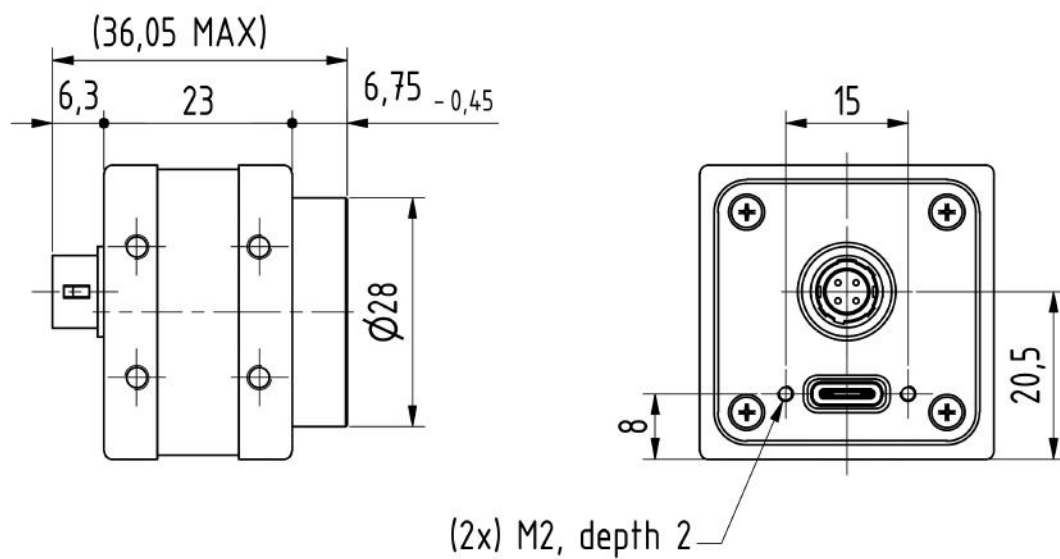
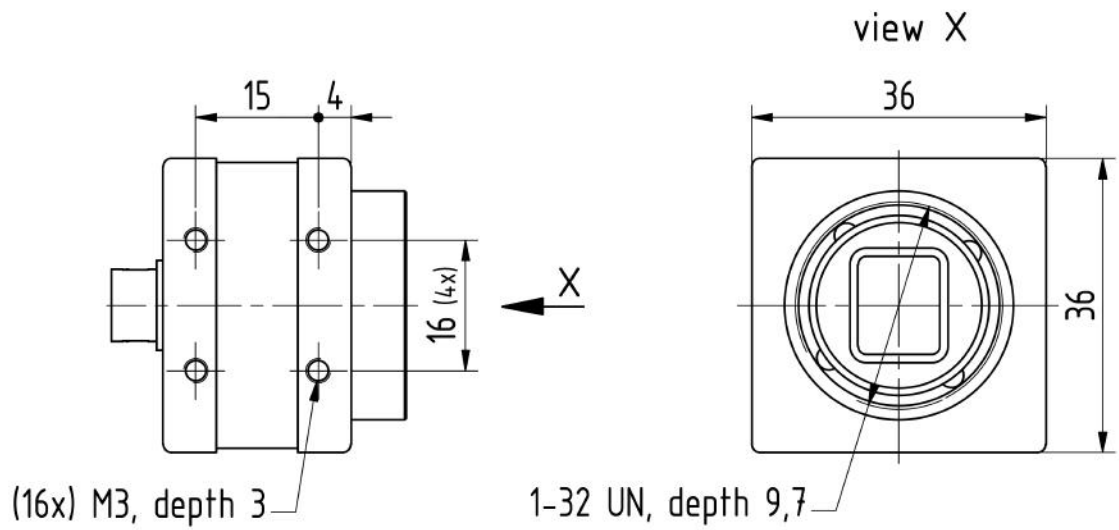

Dimensions: mm  
Tolerances: DIN ISO 2768-f





## 2.3 DMK 37BUX178 CS-Mount with Tripod Adapter

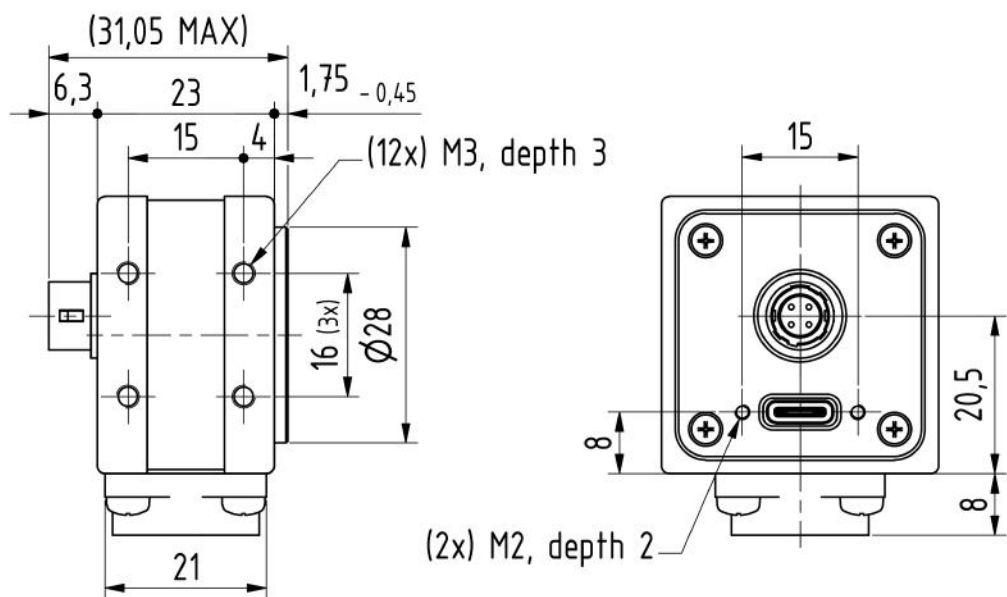
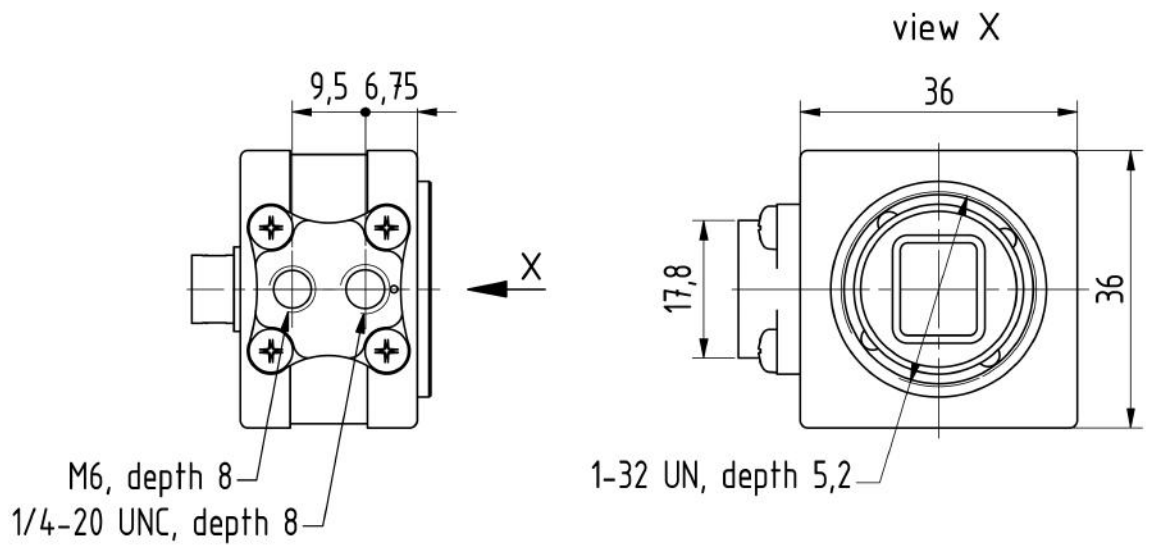

Dimensions: mm  
Tolerances: DIN ISO 2768-f







## 2.4 DMK 37BUX178 CS-Mount without Tripod Adapter

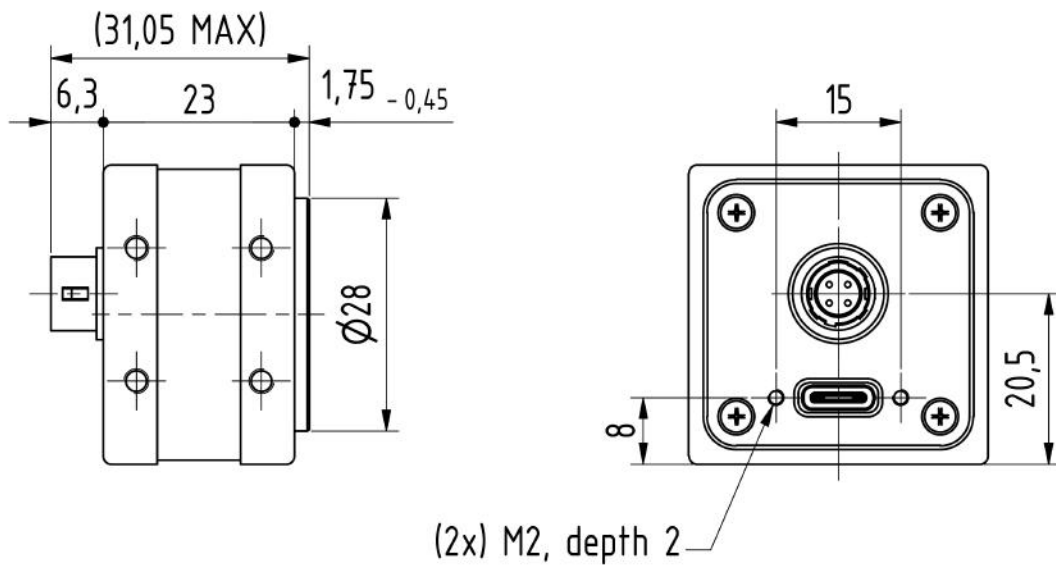
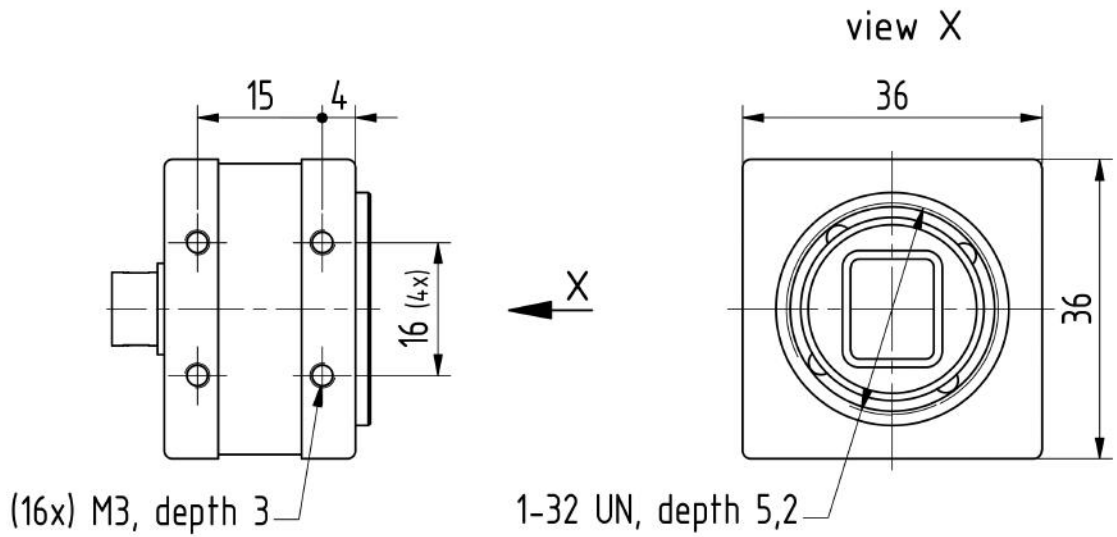

Dimensions: mm  
Tolerances: DIN ISO 2768-f

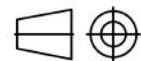



## 3 I/O Connector

### 3.1 4-pin I/O Connector

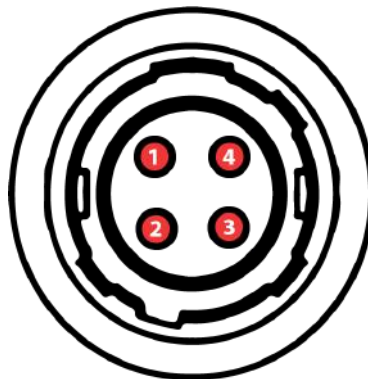

Rear view of camera

Pin	Signal	I/O	Remarks	Characteristics			
				Min	Typ	Max	Unit
1	GND_I/O	G <sup>3</sup>	External Ground	-	-	-	-
2	STROBE_OUT	O <sup>3</sup>	Open drain	-	-	24.0 <sup>1</sup>	V
3	TRIGGER_IN (-)	I <sup>3</sup>	Optocoupler ground	-	-	-	-
4	TRIGGER_IN (+)	I <sup>3</sup>	Optocoupler signal	3.3 <sup>2</sup>	-	24.0 <sup>2</sup>	V

<sup>1</sup> max. 0.2A (ID) for open drain MOSFET!

<sup>2</sup> min. 3.5 mA driver strength required!

<sup>3</sup> G: Ground O: Output I: Input

The part number of this Hirose connector is HR10A-7R-4P. To create an I/O cable you need a Hirose connector HR10A-7P-4S.

#### 3.1.1 TRIGGER\_IN

The *TRIGGER\_IN* line can be used to synchronize the start of the exposure time with external events. The [Trigger](#) section describes in detail how the image sensor's behavior can be controlled.

The current input signal can also be read directly through the [General Purpose Input](#) feature.

#### 3.1.2 STROBE\_OUT

The *STROBE\_OUT* line's main usage is to indicate the integration time of the image sensor which allows flashes, strobes or other light sources to be synchronized with camera operation. The line's behavior can be controlled through the [Strobe](#) controls.



The output signal can also be directly controlled through the [General Purpose Output](#) feature.



## 4 Spectral Characteristics

### 4.1 Spectral Sensitivity - IMX178LLJ-C

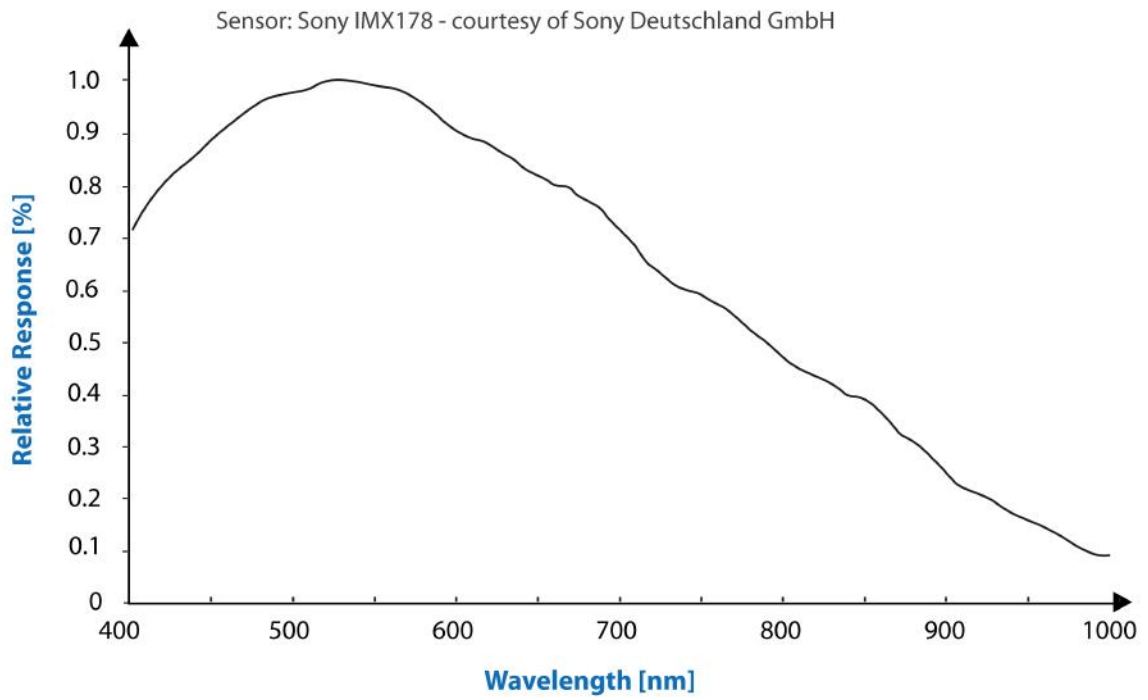



## 5 Camera Controls

This section describes the parameters available for the DMK 37BUX178 camera.

The actual name of the parameter depends on the driver technology used to access the camera. Parameter names are listed for the most common ways to access the cameras:

- *USB3 Vision* (cross platform, via 3rd party driver)
- *UVC/V4L2* (on Linux, via `uvcvideo`)
- *IC Imaging Control* (on Windows, via *Device Driver for The Imaging Source USB 33U, 37U and 38U Cameras*)

### 5.1 Sensor Readout Control

#### 5.1.1 Pixel Format

The pixel format defines the data type of the pixels transmitted to the computer. The bits per pixel needed for a particular pixel format influence the required bandwidth.

The way the pixel format is controlled varies significantly among the driver technology used to access the camera:

- When using *USB3 Vision*, the pixel format is controlled through the `PixelFormatGenICam` feature.
- When using the `uvcvideo` driver on Linux, the pixel format is defined by `video4linux2`.
- When using *IC Imaging Control*, the pixel format is part of the video format - a parameter which combines pixel format, resolution and readout mode. For more information, refer to the *IC Imaging Control* documentation sections on `VideoFormat` and `VideoFormatDesc`.

The DMK 37BUX178 monochrome camera supports multiple pixel formats with variable bits-per-pixel settings. The names of the pixel formats and the way to select them depends on the driver used to control the camera. The following table contains a short overview of all possible formats followed by a more detailed description.

Pixel Format	Bits Per Pixel	USB3 Vision	UVC	TIS UVC Driver
8-Bit Monochrome	8	Mono8	Y800	Y800
12-Bit Packed Monochrome	12	Mono12p	Y12p	Y16
16-Bit Packed Monochrome	16	Mono16	Y16	Y16

##### 5.1.1.1 8-Bit Monochrome

This format transmits data using one byte for each pixel.

*USB3 Vision* drivers see this pixel format as `Mono8`.



UVC drivers see it with the *FourCC* Y800.

The *Device Driver for The Imaging Source USB 33U, 37U and 38U Cameras* offers this pixel format as the Y800 video format.

### 5.1.1.2 12-Bit Packed Monochrome

This format transmits data using 3 bytes for each pair of 2 consecutive pixels.

*USB3 Vision* drivers see this pixel format as Mono12p.

UVC drivers see it with the *FourCC* Y12p.

The *Device Driver for The Imaging Source USB 33U, 37U and 38U Cameras* offers this pixel format as the Y16 video format. Since the DMK 37BUX178 camera offers both 12-bit packed and 16-bit monochrome pixel formats, the driver will use the 12-bit packed format when the Y16 video format is selected.

### 5.1.1.3 16-Bit Monochrome

The sensor of the DMK 37BUX178 camera is not capable of providing 16-bit data output. Instead, the pixel data is transmitted in the most significant bits which allows application programs to ignore the sensor-specific data type, and treat the data as if the sensor outputs 16 bits.

*USB3 Vision* drivers see this pixel format as Mono16.

UVC drivers see it with the *FourCC* Y16.

The *Device Driver for The Imaging Source USB 33U, 37U and 38U Cameras* offers this pixel format as the Y16 video format.

## 5.1.2 Resolution

The DMK 37BUX178 allows the user to specify which rectangular region of the image sensor to read out during camera operation. The size of this rectangle determines the number of pixels that have to be transferred for each frame and has a significant influence on the required USB bandwidth.

Lowering the resolution also often allows the image sensor to operate at a higher frame rate. Changes in the vertical resolution have more effect on the maximum frame rate than changes in the horizontal direction.

The way the resolution is controlled varies greatly between the driver technology used to access the camera:

- When using *USB3 Vision*, the resolution is controlled through the GenICam features Width and Height.
- When using the *uvcdm* on Linux, the resolution is selected from a list of fixed formats. Dynamic frame sizes are not available.
- When using *IC Imaging Control*, the resolution is part of the video format, a parameter that combines pixel format, resolution and readout mode. For more information, refer



to the *IC Imaging Control* documentation sections on `VideoFormat` and `VideoFormatDesc`.

Parameter	Horizontal Resolution
Minimum	256
Maximum	3072
USB3 Vision: GenICam	<code>Width</code>

Parameter	Vertical Resolution
Minimum	4
Maximum	2048
USB3 Vision: GenICam	<code>Height</code>

### 5.1.3 Frame Rate

The frame rate is specified in frames per second and determines the camera's operating speed.

The way the frame rate is controlled depends greatly upon which driver technology is used to access the camera:

- When using *USB3 Vision*, the frame rate is controlled through the *GenICam* feature `AcquisitionFrameRate`.
- When using `ucvvideo` on Linux, the frame rate is selected from a list of available frame rates.
- When using IC Imaging Control, the frame rate is selected from a list of available frame rates through APIs such as `Grabber::setFPS` or `ICImagingControl.DeviceFrameRate`.

The range of available frame rates depends upon other camera settings such as well, pixel format, resolution and readout modes.

Parameter	Frame Rate
Minimum	Depending on Pixel Format, Resolution, and Readout Mode
Maximum	Depending on Pixel Format, Resolution, and Readout Mode
USB3 Vision: GenICam	<code>AcquisitionFrameRate</code>

The following tables show the maximum frame rate for some combinations of pixel format and resolution.

#### 8-Bit Monochrome



Width	Height	Maximum Frame Rate
3072	2048	60
2048	2048	70
1920	1080	130
640	480	284

## 12-Bit Packed Monochrome

Width	Height	Maximum Frame Rate
3072	2048	40
2048	2048	60
1920	1080	121
640	480	284

## 16-Bit Monochrome

Width	Height	Maximum Frame Rate
3072	2048	30
2048	2048	45
1920	1080	91
640	480	284

### 5.1.4 Partial Scan Offset

If the selected resolution is smaller than the sensor size, the part of the sensor that is actually read out can be specified by the *Partial Scan Offset X* and *Partial Scan Offset Y* parameters. By default, the camera automatically positions the offsets so that the center of the sensor is used.

Parameter	Partial Scan Offset X
Minimum	0
Maximum	2816
USB3 Vision: GenICam	OffsetX
Video4Linux2	ROI Offset X
VCD Property	VCDID_PartialScanOffset \VCDElement_PartialScanOffsetX





Parameter	Partial Scan Offset Y
Minimum	0
Maximum	2044
USB3 Vision: GenICam	OffsetY
Video4Linux2	ROI Offset Y
VCD Property	VCDID_PartialScanOffset \VCDElement_PartialScanOffsetY

If *Partial Scan Offset X* or *Partial Scan Offset Y* is configured to a value that would be invalid with the current setting of [Resolution](#) setting, the camera uses the maximum possible value.

Parameter	Partial Scan Auto Center
On	Automatically configure Partial Scan Offset X/Y so that the center area of the sensor is read out
True	
Off	Control Partial Scan Offset X/Y manually
False	
USB3 Vision: GenICam	OffsetAutoCenter
Video4Linux2	ROI Auto Center
VCD Property	VCDID_PartialScanOffset \VCDElement_PartialScanAutoCenter

## 5.1.5 Image Flipping

The DMK 37BUX178 camera allows for horizontal flipping of the image data. The *Flip Horizontal* parameter can be used to control this sensor feature.

Parameter	Flip Horizontal
True	Image data is flipped horizontally
False	Image data is not flipped horizontally
USB3 Vision: GenICam	ReverseX
Video4Linux2	Flip Horizontal
VCD Property	VCDID_FlipHorizontal\VCDElement_Value

## 5.2 Image Sensor Control



## 5.2.1 Exposure Time

The *Exposure Time* parameter defines the time the camera opens its (electronic) shutter when it is taking an image.

Parameter	Exposure Time
Minimum	20 $\mu$ s
Maximum	60 s
Default	auto
USB3 Vision: GenICam	ExposureTime
Video4Linux2	Exposure Time (us)
VCD Property	VCDID_Exposure\VCDElement_Value

## 5.2.2 Gain

The *Gain* parameter defines the amplification that is applied to the image at sensor level.

Parameter	Gain
Minimum	0 dB
Maximum	48 dB
Default	auto
USB3 Vision: GenICam	Gain
Video4Linux2	Gain (db/100)
VCD Property	VCDID_Gain\VCDElement_Value

## 5.2.3 Black Level

The *Black Level* parameter defines the lowest possibly intensity value of the image sensor.



Parameter	Black Level
Minimum	0
Maximum	4095
Default	200
USB3 Vision: GenICam	BlackLevel
Video4Linux2	Brightness
VCD Property	VCDID_Brightness\VCDElement_Value

## 5.3 Automatic Exposure and Gain Control

The DMK 37BUX178 camera can automatically control gain and exposure time. These automatic functions are enabled by default.

In order to optimize image parameters, a region of interest can be specified for automatic functions. Specifying a region of interest enables fine-grained control over the image area for which the image parameters are optimized. A selection of pre-defined area presets is available, but the user can also specify the coordinates of a custom rectangle.

In certain situations, it is desirable to limit the range of the auto-controlled parameters. For example, one might want to avoid high gain settings in order to keep noise levels low. Other applications require limiting the maximum exposure time so that movements do not get blurred. Therefore, the ranges of the gain and exposure parameter can be limited.

If both auto exposure and auto gain are active, the camera tries to lower the gain value in order to reduce noise and improve the image quality.

### 5.3.1 Auto Exposure

Parameter	Auto Exposure
Continuous	Enable Auto Exposure
True	
Off	Disable Auto Exposure
False	
USB3 Vision: GenICam	ExposureAuto
Video4Linux2	Auto Shutter
VCD Property	VCDID_Exposure\VCDElement_Auto



## 5.3.2 Auto Gain

Parameter	Auto Gain
Continuous	Enable Auto Gain
True	
Off	Disable Auto Gain
False	
USB3 Vision: GenICam	GainAuto
Video4Linux2	Auto Gain
VCD Property	VCDID_Gain\VCDElement_Auto

## 5.3.3 Auto Reference Value

The *Auto Reference Value* parameter specifies the target brightness for both auto exposure and auto gain.

Parameter	Auto Reference Value
Minimum	0
Maximum	255
Default	128
USB3 Vision: GenICam	ExposureAutoReference
Video4Linux2	ExposureAutoReference
VCD Property	VCDID_Exposure\VCDElement_AutoReference

## 5.3.4 Highlight Reduction

Enabling *Highlight Reduction* lets the auto exposure and auto gain functions reduce overexposed areas in the output image. This feature is particularly useful when using 10/12/16-bit output images and a tone mapping algorithm in post-processing when using higher bit depths as the dark areas still contain a lot of useful information.

Parameter	Highlight Reduction
True	Try to reduce overexposed areas
False	Ignore overexposed areas and focus on matching the image brightness to the selected <a href="#">Auto Reference Value</a> .
USB3 Vision: GenICam	ExposureAutoHighlightReduction
Video4Linux2	Highlight Reduction
VCD Property	VCDID_HighlightReduction\VCDElement_Value



## 5.3.5 Auto Exposure Limits

The *Auto Exposure Lower Limit* parameter determines the minimum possible value that can be set by the auto exposure algorithm.

Parameter	Auto Exposure Lower Limit
Minimum	20 $\mu$ s
Maximum	1 s
USB3 Vision: GenICam	ExposureAutoLowerLimit
Video4Linux2	Exposure Auto Lower Limit

The *Auto Exposure Upper Limit* parameter determines the maximum possible value that can be set by the auto exposure algorithm.

Parameter	Auto Exposure Upper Limit
Minimum	20 $\mu$ s
Maximum	1 s
USB3 Vision: GenICam	ExposureAutoUpperLimit
Video4Linux2	Exposure Auto Upper Limit
VCD Property	VCDID_Exposure\VCDElement_AutoMaxValue

If the *Auto Exposure Upper Limit Auto* parameter is enabled, the value of *Auto Exposure Upper Limit* is automatically kept at the maximum possible value for the current frame rate.

Parameter	Auto Exposure Upper Limit Auto
On	Select <i>Auto Exposure Upper Limit</i> automatically
Off	Let the user control <i>Auto Exposure Upper Limit</i>
USB3 Vision: GenICam	ExposureAutoUpperLimitAuto
UVC	Exposure Auto Upper Limit Auto
Video4Linux2	VCDID_Exposure\VCDElement_AutoMaxValueAuto

## 5.3.6 Auto Gain Limits

The *Auto Gain Lower Limit* parameter determines the minimum possible value that can be set by the auto gain algorithm.



Parameter	Auto Gain Lower Limit
Minimum	0 dB
Maximum	48 dB
USB3 Vision: GenICam	GainAutoLowerLimit
Video4Linux2	Gain Auto Lower Limit

The *Auto Gain Upper Limit* parameter determines the maximum possible value that can be set by the auto gain algorithm.

Parameter	Auto Gain Upper Limit
Minimum	0 dB
Maximum	48 dB
USB3 Vision: GenICam	GainAutoUpperLimit
Video4Linux2	Gain Auto Upper Limit

## 5.4 Trigger

The trigger mode can be used to take images at very specific points in time which are specified by an electrical signal connected to the [TRIGGER\\_IN](#) pin of the I/O connector of the camera.

### 5.4.1 Trigger Mode

The *Trigger Mode* parameter enables the trigger mode.

Parameter	Trigger Mode
On	Enable Trigger Mode
True	
Off	Disable Trigger Mode
False	
USB3 Vision: GenICam	TriggerMode
Video4Linux2	Trigger Mode
VCD Property	VCDID_Trigger\VCDElement_Value

### 5.4.2 Trigger Polarity

The *Trigger Polarity* parameter controls whether a trigger event is accepted on the rising or falling edge of the signal connected to the TRIGGER\_IN line.



Parameter	Trigger Polarity
RisingEdge	Accept rising edge as trigger signal
True	
FallingEdge	Accept falling edge as trigger signal
False	
USB3 Vision: GenICam	TriggerActivation
Video4Linux2	Trigger Polarity
VCD Property	VCDID_Trigger\VCDElement_Polarity

### 5.4.3 Trigger Operation

The *Trigger Operation* parameter controls the operation mode of the sensor in trigger mode.

Rolling shutter sensors can use the *Global Reset Release* mode when being triggered. In this mode, the integration time starts simultaneously for all lines. At the end of the nominal exposure time, the sensor then stops integrating and starts reading out the lines - as it is typical for a rolling shutter. Therefore, every line has a slightly longer actual exposure time than the line above it.

Parameter	Trigger Operation
Default	Default mode
GlobalResetRelease	Use Global Reset Release mode
USB3 Vision: GenICam	TriggerOperation
Video4Linux2	Trigger Operation
VCD Property	VCDID_Trigger\VCDElement_TriggerOperation

### 5.4.4 Software Trigger

The *Software Trigger* function can be used to simulate a trigger pulse, in turn causing one image to be exposed and delivered to the host computer.

Parameter	Software Trigger
Execute	Simulate one trigger pulse
USB3 Vision: GenICam	TriggerSoftware
Video4Linux2	Software Trigger
VCD Property	VCDID_Trigger\VCDElement_SoftwareTrigger



## 5.4.5 Trigger Overlap

The *Trigger Overlap* feature gives information on when a new trigger pulse is accepted in the trigger -> exposure -> readout sequence.

Parameter	Trigger Overlap
Off	The next trigger pulse is only accepted once the previous frame has been read out from the sensor
Readout	The next trigger pulse is accepted during readout as long as the remaining readout time is shorter than the exposure time
USB3 Vision: GenICam	TriggerOverlap
VCD Property	VCDID_Trigger\VCDElement_TriggerOverlap

## 5.5 Trigger Timing Parameters

The 37U series camera series offers several options for dealing with bad trigger signals. By using the *Debounce Time*, *Denoise Time* and *Mask Time* parameters, the camera can be configured to ignore pulses on its [TRIGGER\\_IN](#) line under certain conditions.

Useful values for these parameters are application-specific. They depend on the expected trigger frequency, the exposure time and assumptions about the input signal quality.

The default values for all these parameters is 0  $\mu$ s, assuming perfect signal quality.

### 5.5.1 Trigger Delay

The *Trigger Delay* parameter specifies a time for which the camera waits between receiving a trigger signal and starting the exposure of an image. Simulated trigger pulses generated through the *Software Trigger* function are not delayed by this parameter.

Parameter	Trigger Delay
Minimum	0 s
Maximum	1 s
Default	0 s
USB3 Vision: GenICam	TriggerDelay
Video4Linux2	Trigger Delay
VCD Property	VCDID_Trigger\VCDElement_TriggerDelay





## 5.6 Digital I/O

The 37U series has one digital input and one digital output. The digital input can be used as a [Trigger](#) input but the current status can also be examined directly.

The digital output can be configured as a [Strobe](#) output to signal the exact moment when the image sensor is sensitive to light so that external light sources can be synchronized to its operation cycle.

### 5.6.1 General Purpose Input

The *General Purpose Input* parameter allows the current status of the [TRIGGER\\_IN](#) pin.

Parameter	General Purpose Input
True	TRIGGER_IN line status is low
1	
False	TRIGGER_IN line status is high
0	
USB3 Vision: GenICam	GPIIn
Video4Linux2	GPIN
VCD Property	VCDID_GPIO\VCDElement_GPIORead VCDID_GPIO\VCDElement_GPIOIn

### 5.6.2 General Purpose Output

The *General Purpose Output* parameter controls the status of the [STROBE\\_OUT](#) pin.

Parameter	General Purpose Output
True	Drive the STROBE_OUT line high
1	
False	Drive the STROBE_OUT line low
0	
USB3 Vision: GenICam	GPOut
Video4Linux2	GPOUT
VCD Property	VCDID_GPIO\VCDElement_GPIOWrite VCDID_GPIO\VCDElement_GPIOOut

## 5.7 Strobe

The strobe function controls the automatic generation of output pulses on the [STROBE\\_OUT](#) pin which is synchronized to the image sensor's exposure time.



## 5.7.1 Strobe Enable

The *Strobe Enable* parameter enables the automatic generation of strobe pulses.

Parameter	Strobe Enable
On	Strobe enabled
True	
Off	Strobe disabled
False	
USB3 Vision: GenICam	StrobeEnable
Video4Linux2	Strobe Enable
VCD Property	VCDID_Strobe\VCDElement_Value

## 5.7.2 Strobe Polarity

The *Strobe Polarity* parameter can be used to invert the strobe pulse output.

Parameter	Strobe Polarity
ActiveHigh	The STROBE_OUT pin is logically high during the exposure time
True	
ActiveLow	The STROBE_OUT pin is logically low during the exposure time
False	
USB3 Vision: GenICam	StrobePolarity
Video4Linux2	Strobe Polarity
VCD Property	VCDID_Strobe\VCDElement_StrobePolarity

## 5.7.3 Strobe Operation

The *Strobe Operation* parameter specifies how the length of the strobe pulses are controlled.



Parameter	Strobe Operation
Exposure	Output pulse duration is equal to the current exposure time
True	
FixedDuration	Output pulse duration is specified by <i>Strobe Duration</i>
False	
USB3 Vision: GenICam	StrobeOperation
Video4Linux2	Strobe Exposure
VCD Property	VCDID_Strobe\VCDElement_StrobeMode

## 5.7.4 Strobe Duration

The *Strobe Duration* parameter controls the length of the strobe pulses if *Strobe Operation* is set to use the fixed duration mode.

Parameter	Strobe Duration
Minimum	0 $\mu$ s
Maximum	32767 $\mu$ s
USB3 Vision: GenICam	StrobeDuration
Video4Linux2	Strobe Duration
VCD Property	VCDID_Strobe\VCDElement_StrobeDuration

## 5.7.5 Strobe Delay

The *Strobe Delay* parameter can be used to add a small delay between the start of exposure and the strobe output pulse.

Parameter	Strobe Delay
Minimum	0 $\mu$ s
Maximum	32767 $\mu$ s
USB3 Vision: GenICam	StrobeDelay
Video4Linux2	Strobe Delay
VCD Property	VCDID_Strobe\VCDElement_StrobeDelay

## 5.8 Region of Interest for Auto Functions

The 37U series cameras allow for the setting of a region of interest that is used while controlling the [Auto Exposure](#), [Auto Gain](#) and Auto White Balance functions.



## 5.8.1 Auto Functions ROI Enable

The *Auto Functions ROI Enable* parameter allows for the use of a region of interest for auto functions.

Parameter	Auto Functions ROI Enable
True	Auto functions only take a specified part of the image into account
False	Auto functions look at the whole image
USB3 Vision: GenICam	AutoFunctionsROIEnable
Video4Linux2	Auto Functions ROI Enable
VCD Property	VCDID_AutoRoi\VCDElement_Value

## 5.8.2 Auto Functions ROI Preset

The *Auto Functions ROI Preset* parameter lets the user select from a list of ROI presets.

Parameter	Auto Functions ROI Preset
Center 50%	Select a rectangular area in the center of the output image
USB3 Vision: GenICam	AutoFunctionsROI_Preset
Video4Linux2	Auto Functions ROI Preset
VCD Property	VCDID_AutoRoi\VCDElement_AutoRoiPreset



## 6 Revision History

Date	Version	Description
2018/04/19		Initial release of this document



## DMK 37BUX178 Technical Reference Manual

All product and company names in this document may be trademarks and tradenames of their respective owners and are hereby acknowledged.

The Imaging Source Europe GmbH cannot and does not take any responsibility or liability for any information contained in this document. The source code presented in this document is exclusively used for didactic purposes. The Imaging Source does not assume any kind of warranty expressed or implied, resulting from the use of the content of this document or the source code.

The Imaging Source Company reserves the right to make changes in specifications, function or design at any time and without prior notice.

Last update: April 2019

© 2019 The Imaging Source

All rights reserved. Reprint, also in parts, only allowed with permission of The Imaging Source Europe GmbH.

All weights and dimensions are approximate. Unless otherwise specified, the lenses shown in the context of cameras are not shipped with these cameras.

Distribution Partner:



# SCORPION VISION

 [shop.scorpion.vision](http://shop.scorpion.vision)  +44 (0) 1590 679333  [sales@scorpion.vision](mailto:sales@scorpion.vision)

### Headquarters:

*The Imaging Source Europe GmbH  
Überseetor 18, D-28217 Bremen, Germany  
Phone: +49 421 33591-0*

### North & South America:

*The Imaging Source, LLC  
6926 Shannon Willow Rd, S 400, Charlotte, NC 28226, USA  
Phone: +1 704-370-0110*

### Asia Pacific:

*The Imaging Source Asia Co., Ltd.  
2F., No.8, Xinhua 1st Road  
Taipei City 114, Neihu District, Taiwan  
Phone: +886 2-2792-3153*

[www.theimagingsource.com](http://www.theimagingsource.com)