

Arducam **64MP OwlSight**

Autofocus Camera Module

For Raspberry Pi

December , 2023

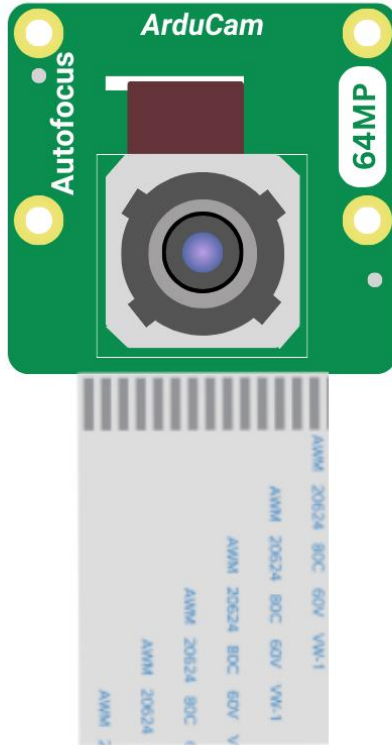

by ARDUCAM TECHNOLOGY CO., LIMITED

Overview



Arducam 64MP OV64A40 OwlSight Camera is a 64MP, Ultra high-resolution autofocus camera module exclusively built for the latest and future RaspberryPi platforms and fully compatible with libcamera stack.

With a remarkable 64MP OV64A40 sensor boasting the leading optical format and the largest pixel size in their class, these cameras excel in challenging lighting conditions while delivering exceptional performance in well-lit environments.

Say goodbye to complex installations, as these cameras are directly supported by libcamera, making setup a breeze.

Even if you are using Raspberry Pi for the first time, you can also follow the hands-on manual guide without hassle or complex operation.

The package comes with a camera module, a 15cm 15pin-15pin FFC cable, and 15cm 15pin-22pin FPC cable by default, there is also an optional camera tripod. (If you need the camera tripod, you can contact sales@arducam.com for help.

Features

Highlight Features:

- **Native Supported by libcamera:** Raspberry Pi mainstream software libcamera directly drives the camera, eliminating the need to install the camera driver and simplifying user access.

Thanks to the 'libcamera Revolution', no more headaches over driver installations or compatibility concerns. The libcamera ecosystem has streamlined the process, making it a breeze to connect and use our camera module on your Linux-based systems.

- **Excellent photosensitive performance:** larger optic format (1/1.32). The largest pixel size among sensors of the same level.

It thrives in all lighting conditions, setting a new standard for performance. The secret lies in its sensor, boasting the largest pixel size (1.008 μ m) and leading optical format (1/1.32") in its class.

- **Ultra-high resolution:** ultra-clear picture quality, maximum resolution 9248x 6944 (64MP).

Based on OmniVision 64MP OV64A40 ultra-high resolution image sensor. Able to obtain clearer images, high-quality video data, and extremely fine picture details.

- **Rich peripheral accessories:** one-stop supporting parts and the overall industry ecosystem. From modules -> products -> solutions.

Rich accessories and product ecosystem, ultra-wide compatibility, compatible with multiple embedded vision/depth vision solutions including multiple cameras, Ethernet cable extension, HDMI extension, Pan-Tilt kit, V3link camera extension, etc.

- **Raspberry Pi 5 is NATIVELY SUPPORTED**

"..Native support for Raspberry Pi's latest high-performance platform Raspberry Pi 5.."

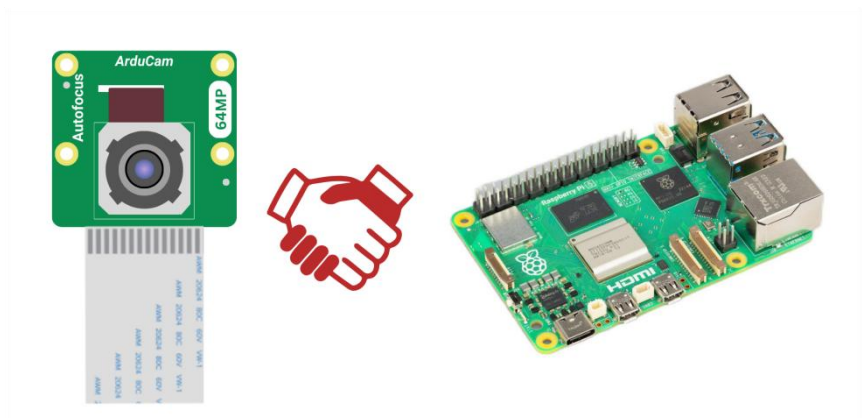

Specifications

Specification	
Image Sensor	OV64A40
Still Resolution	64 Megapixels
Color Filter Type	Color
Shutter Type	Rolling
Optical Size	1/1.32"
Pixel Size	1.008 μm x 1.008 μm
Sensor Active Area	9248(H) \times 6944(V)
Output Format	JPEG/YUV/RGB/RAW10
Video Modes (on Raspberry Pi)	1080p30,720p60 and 640 \times 480p60/90
Video Modes (Camera Module)	9152 \times 6944@2fps, 4624 \times 3472@7.6fps, 3840 \times 2160@14.8fps, 2312 \times 1736@26.7fps, 1920 \times 1080@45fps
IR Sensitivity	Integral IR-cut Filter, visible light only
Lens	
Focus Type	Manual/Auto
Focal Length	6.65mm
F.NO	F1.9
Field of View (FOV)	84 $^{\circ}$ (D) \times 68 $^{\circ}$ (H) \times 56 $^{\circ}$ (V)
Lens Mount	Stock Lens
Default Focus Range	12cm $\sim\infty$

Electrical and Mechanical	
Power Requirements	3.3V/300mA
Camera Board Size	25×24 mm
Functionality and Compatibility	
Supported OS	Raspberry Pi OS
Supported Platforms*	Raspberry Pi 5/4B/3B+/3/2/CM3/CM4/Zero W /Zero 2 W

▲ Raspberry Pi 2/3/zero W may not be able to enable maximum resolution due to RAM, please make sure your platform has RAM greater than or equal to 1G.

▲ Capturing maximum resolution on the Pi 4 and CM4 may be impacted by CMA, which can be fixed by switching the GUI mode to terminal mode.

Resolution & Frame Rates

Sensor	Transfer Speed	Resolution	Frame Rate
OV64A40	High Speed	9152×6944	2.6fps
		4624×3472	10fps
		3840×2160	20fps
		2312×1736	30fps
		1920×1080	60fps
	Low Speed	9152×6944	2fps
		4624×3472	7.6fps
		3840×2160	14.8fps
		2312×1736	26.7fps
		1920×1080	45fps

Physical Size

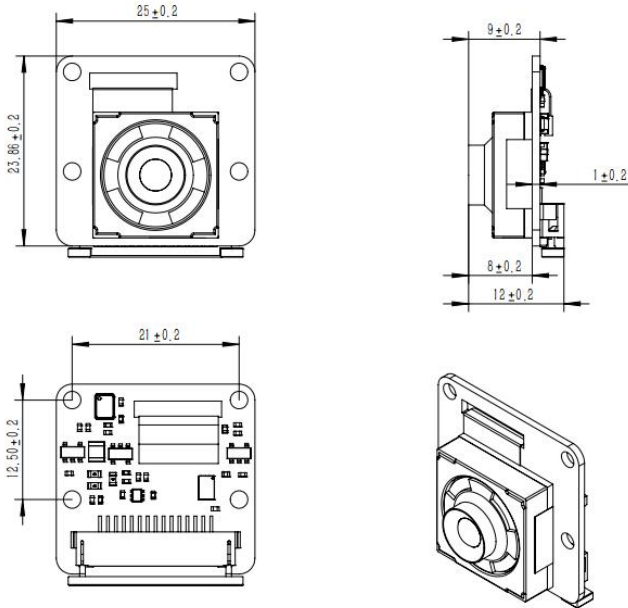

Safety Instructions

First time using a Raspberry Pi camera? Please note:

- Before connecting, you should always power the Raspberry Pi off and remove the power supply first.
- Avoid high temperatures.
- Avoid water, moisture, or conductive surfaces while in operation.
- Avoid cross-threading with tripods. Avoid folding or straining the flex cable.
- Gently push/pull the connector to avoid damaging the printed circuit board.
- Avoid moving or handling the printed circuit board excessively while it's in operation.
- Handle by the edges to avoid damage from electrostatic discharge.
- where the camera board is stored should be cool and as dry as possible.
- sudden temperature/humidity changes can cause dampness in the lens and affect the image/video quality.

Product Display

ArduCam

SKU: B0483



Quick Start Guide

Please refer to the below doc link for online General Quick Start Guide and detailed information:

<https://docs.arducam.com/Raspberry-Pi-Camera/Native-camera/64MP-OV64A40/>

Distribution Partner:



**SCORPION
VISION**

🌐 shop.scorpion.vision ☎ +44 (0) 1590 679333 @ sales@scorpion.vision

Visit us at

www.arducam.com

Pre-sale

info@arducam.com

Technical Support

support@arducam.com

Skype:Arducam

ARDUCAM TECHNOLOGY CO., LIMITED