

HEMPALTA CORP.

TSXV:HEMP

HEMPALTA™

INNOVATING THE INDUSTRIAL
HEMP INDUSTRY

SPRING 2024

WWW.HEMPALTA.COM

Disclaimer

GENERAL

This corporate presentation (this "Presentation") has been prepared by the management of Hempalta Corp. (the "Company", "Hempalta" or "HEMPALTA") for informational purposes only and is not intended to provide investing, financial, tax, legal or accounting advice. This Presentation is not prepared to assist any reader in making a decision whether to invest in Hempalta and the contents of this Presentation have not been approved or disapproved by any securities commission or regulatory authority in Canada, the United States or any other jurisdiction. The contents of this Presentation do not constitute or form part of any advertisement, any offer to sell or any solicitation of an offer to buy or subscribe for securities of Hempalta or represent an intention to induce any person to make an investment in the Company or to assist any person in the making of an investment decision. Any estimates or projections or opinions contained herein necessarily involve a significant element of subjective judgment, analysis and assumption and each reader should satisfy itself in relation to such matters. Hempalta expressly disclaims any duty on Hempalta to make disclosure or any filings with any securities commission or regulatory authority, beyond that imposed by applicable laws. References to dollars or "\$" are to Canadian dollars unless specified otherwise. Unless otherwise indicated, the information provided in this Presentation is provided as of March 25, 2024.

Market and Industry Data

This Presentation includes market data and industry forecasts that the Company has obtained from industry publications, market research reports and/or other published independent sources. Such publications and reports generally state that the information contained therein has been obtained from sources believed to be reliable. Although the Company believes these publications and reports to be reliable, it has not independently verified any of the data or other statistical information contained therein, nor has it ascertained or validated the underlying economic or other assumptions relied upon by these sources. The Company has no intention and undertakes no obligation to update or revise any such information or data, whether as a result of new information, future events or otherwise, except as, and to the extent required by applicable securities laws. The Company hereby disclaims any responsibility or liability whatsoever in respect of any third-party sources of market and industry data or information.

Forward-Looking Information

This Presentation contains certain statements and information that, to the extent they are not historical fact, may constitute "forward-looking information" under applicable securities laws. Such forward-looking information is used in this Presentation for the purpose of providing information about management's current expectations and plans relating to the future development of Hempalta's business. Readers are cautioned that reliance on such information may not be appropriate for other purposes, such as making investment decisions. Forward-looking information typically contains statements with words such as "aim", "believe", "expect", "plan", "intend", "estimate", "ideal", "forecast", "propose", "project", "should", "target", "will", "may", "potential" or similar words suggesting future outcomes or statements regarding an outlook. Forward-looking information in this Presentation includes, but is not limited to, statements or information with respect to: [NTD: Placeholder to add additional FLI based on final version of presentation] the Company's business model and plan, including anticipated activities, opportunities, strategies and objectives; Hempalta's business strategy and objectives, including the proposed sale of hemp carbon credits; potential new revenue stream for Hempalta through hemp carbon credits; Hempalta's option to purchase 50% of Hemp Carbon Standard; the potential results from Hempalta's partnership with Hemp Carbon Standard; Hempalta's roadmap and production achievements, including the achievement of 100% double-shift production capacity with one HempTrain; the realization of the first full cycle of carbon credit revenue derived from measuring, reporting and verifying the carbon credits; future plans for Hempalta; expected demand for Hempalta's products and services; the anticipated product or service offerings of Hempalta; and certain other expectations, beliefs, plans, objectives, assumptions, intentions or statements about future events or performance.

The forward-looking information is based on a number of factors and assumptions which have been used to develop such information, and which may prove to be incorrect. Such factors and assumptions include, but are not limited to: estimates of the financial and operational performance of Hempalta; the ability of the Company to successfully implement its strategic plans and initiatives and whether such strategic plans and initiatives will yield the expected benefits; the operating performance of Hempalta's assets and businesses; the impact of competition from other industry participants; the general stability of the economic and political environment in which Hempalta operates; the sufficiency of budgeted capital expenditures in carrying out planned activities; the ability of Hempalta to obtain qualified staff, equipment and services in a timely and cost efficient manner; the timely receipt of any required regulatory approvals for the business plans of Hempalta; the ability of Hempalta to obtain future financing on acceptable terms; anticipated costs of capital expenditures relating to the products of Hempalta; that Hempalta will have sufficient capital to conduct its business plan; currency, exchange and interest rates; the regulatory framework regarding taxes and regulatory matters in the jurisdictions in which Hempalta operates; the success that Hempalta may have in developing its products; assumptions of costs associated with development plans; competitive factors in the industries in which the Company operates and in which it plans to operate; laws and regulations affecting Hempalta's business; and general economic conditions. Readers are cautioned that the foregoing list is not exhaustive of all factors and assumptions which have been used.

The forward-looking information is subject to known and unknown risks and factors that could cause actual results to vary (including materially) from those anticipated by Hempalta and described in the forward-looking information. Such risks and uncertainties include, without limitation: the impact of general economic and business conditions in Canada, the United States and overseas; industry conditions; changes in laws and regulations and changes in how they are interpreted and enforced; that Hempalta might not be able to successfully market and sell any hemp carbon credits, and if its able to market and sell hemp carbon credits, that the revenues and profits from such marketing and sale will not be as anticipated; the ability of management to execute its business plan; the ability of Hempalta to develop its current and future products; potential delays or changes in plans with respect to Hempalta's product development or capital expenditures; the uncertainty of estimates and projections; foreign currency exchange rates and interest rates; risks inherent in Hempalta's marketing operations; regulatory risks; increased competition; the risk of disruptions to the Company's supply chain; the lack of availability of qualified personnel; risks associated with the Company's reliance on key personnel; changing consumer sentiments; risks associated with potential lawsuits and regulatory actions against Hempalta; uncertainties as to the availability and cost of financing; and risks related to the inability to obtain services as may be necessary. Readers are cautioned that the foregoing list of possible risks and factors is not exhaustive.

Hempalta's actual results, performance or achievement could differ (including materially) from those expressed in, or implied by, the forward-looking information and, accordingly, no assurance can be given that any of the events anticipated by the forward-looking information will transpire or occur, or if any of them do so, what benefits that Hempalta will derive therefrom. Readers should not place undue reliance on any such forward-looking information. The forward-looking information is made as at the date of this Presentation and Hempalta does not undertake any obligation to update publicly or to revise any of the included forward-looking information, whether as a result of new information, future events, circumstances or otherwise, except as may be required by applicable securities laws. Historical statements should not be taken as a representation that such trends will be replicated in the future. No information or statement is intended to be nor may be construed as a profit forecast.

Use of Presentation

By your receipt of this Presentation, you and any person reviewing this document agree not to do any of the following in respect of this Presentation or any information contained herein without the prior written permission from Hempalta: (1) use for any unapproved purpose; (2) copy; (3) reproduce; (4) publish; or (5) condone, permit or authorize the using for any unapproved purposes, copying, reproduction, or publication thereof by any other person or entity, including to members of the public or media. Any failure to comply with this restriction may constitute a violation of applicable securities law.

COMPANY HIGHLIGHTS



NEW POTENTIAL REVENUE STREAM THROUGH HEMP CARBON CREDITS:

HEMPALTA is the first company in Canada to introduce industrial hemp carbon removal credits to the market through its strategic partnership with Hemp Carbon Standard (HCS), creating a potential new revenue stream.



GROWING MARKET OPPORTUNITY FOR INDUSTRIAL HEMP:

The global industrial hemp market is projected to grow, rising from \$6.8 Billion USD in 2022 to \$18.1 Billion USD in 2027.¹



FIRST MOVER ADVANTAGE WITH HEMP CARBON REMOVAL CREDITS:

- HCS ability to measure, report and verify (MRV) hemp removal credits on a global scale.
- Exclusive licensing rights to HCS's technology for Alberta and Saskatchewan.
- Opportunity to deepen strategic partnership with HCS.



READY TO SCALE THROUGH INNOVATIVE MANUFACTURING PROCESS:

- Exclusive rights for the purchase and operation of the state-of-the-art HempTrain™ advanced processing system for Southern Alberta.
- Plant expansion opportunities are to be considered in 2024/2025 to meet market demand.



VOLUNTARY CARBON CREDIT MARKET OPPORTUNITY:

- The voluntary carbon credit market is expected to grow to \$2.68 Trillion USD by 2028 at a CAGR of 18.23%.²
- Partnership with HCS could result in over 1 million acres being measured, reported and verified (MRV) for creation of carbon credits that can be sold on the voluntary carbon credit market.³



SEASONED LEADERSHIP TEAM AND OPERATORS:

- Led by Founder & CEO Darren Bondar with over 20 years of experience in driving business performance & developing a powerful network.
- Previous company sold for \$131 Million in 2021.
- Complementing his expertise, the team possesses extensive backgrounds in operations, manufacturing, marketing, consumer packaged goods, and retail sales.

1. Industrial Hemp Market by Type (marketsandmarkets.com)
2. Global Carbon Credit Market 2023: Sector to Reach \$2.68 Trillion by 2028 at a CAGR of 18.23% (yahoo.com)
3. See Disclaimer

THE MANY USES OF HEMP

INDUSTRIAL HEMP CAN BE USED IN MORE THAN **25,000** PRODUCTS.

- 100% biodegradable, recyclable and reusable
- Industrial hemp can absorb between 10-22 tonnes of CO2 per hectare ¹
- Industrial hemp is more efficient at CO2 sequestration than agroforestry ¹
- The production of industrial hemp is carbon-negative
- Hemp is highly versatile as it can be grown in a variety of climates and soil conditions and does not take years to grow

FIBER

Technical Fiber

- Concrete Reinforcement
- Construction Materials
- Automotive Compression Molding
- Fiberglass Replacements
- Plastics Reinforcements & Fillers
- Cordage
- Paper
- Mats
- Geotextiles
- Brakes/clutch Lining
- Loss Circulation Control
- Thermal & Sound Insulation

Textiles

- Clothing
- Shoes
- Handbags
- Diapers

HURD (SHIV)

- Cat Litter
- Potting Mix
- Food Preservation
- Soil Amendment
- Hempcrete
- Fiberboard
- Insulation
- Absorption Products
- Fillers
- Paper
- Hydroponic Retention
- Animal Bedding
- Mulch/landscaping

GREEN MICROFIBER

- Skin Care Products
- Pet Food Supplement
- Infused Beverages
- Soil Amendment



FLOWER

- Pharmaceutical
- Consumables

SEEDS

Biofuel

Food

- Oil
- Protein Flour
- Seeds
- Beer
- Animal Feed

Personal Care

- Shampoos/soaps
- Cosmetics
- Lotions

Technical Fluids

- Lubricants
- Solvents
- Oil Paints
- Varnishes

LEAVES

- Pharmaceutical
- Consumables

ROOTS

- Improves Soil Health
- Reduces Water Pollution
- Benefits Crop Rotation

HOW IT WORKS

WE CONTRACT FARMERS TO GROW INDUSTRIAL HEMP & JOIN OUR CARBON CREDIT PROGRAM. WE THEN OBTAIN THE BIOMASS AND CONVERT IT TO ENVIRONMENTALLY SUSTAINABLE HEMP PRODUCTS FOR B2B & B2C CUSTOMERS. OUR STRATEGIC PARTNER HCS SIMULTANEOUSLY MEASURE, REPORTS, VERIFIES, & MARKET CARBON REMOVAL CREDITS TO GLOBAL COMPANIES THAT NEED TO OFFSET THEIR EMISSIONS.

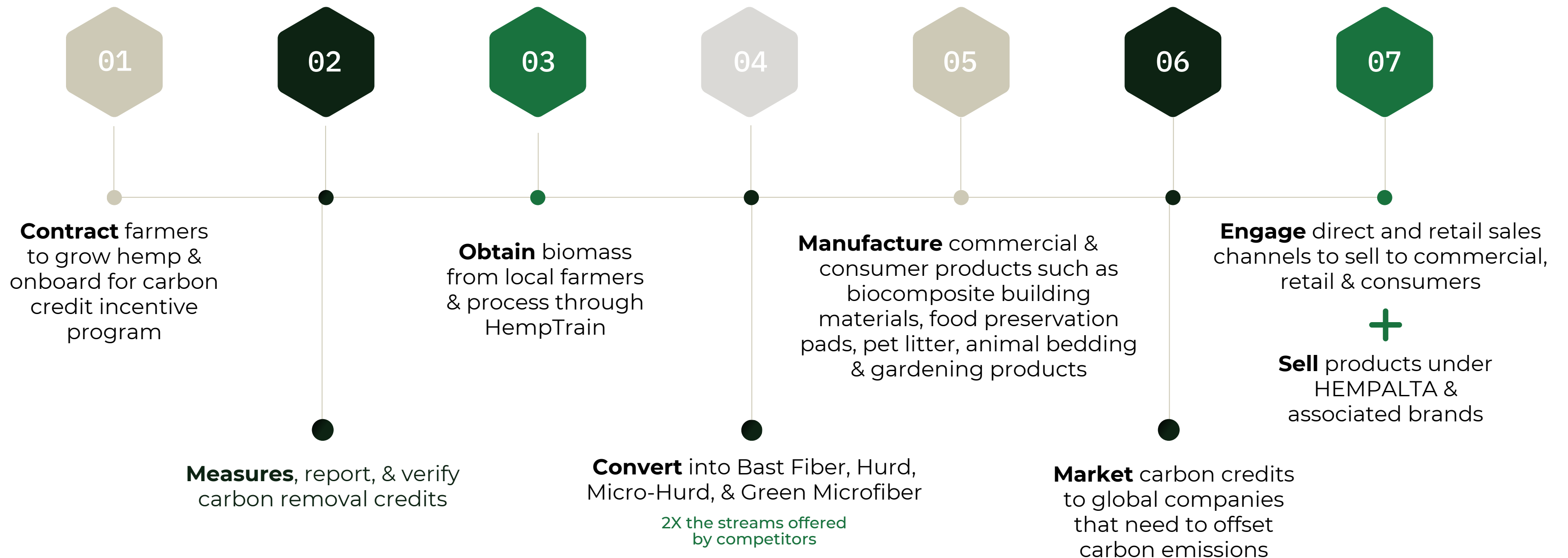

CARBON CREDIT OPPORTUNITY



The strategic partnership with HSC and right to their technology positions us as a trailblazer in the hemp carbon credit generation industry



10-22 tonnes of CO2 are absorbed per hectare through hemp cultivation, positioning us as a key player in the market while strategically partnering with HCS, creating a potential new revenue stream ¹



Contributing to reducing greenhouse gas emissions, aligning our efforts with global climate goals



HIGHLIGHTS OF LICENSED HEMPTRAIN™ TECHNOLOGY

Conventional decorticators (hammer mills, scutchers, etc.) use technology that is, in some cases, over a century old. These mechanisms were designed for destruction of their feedstock, damaging the hemp and causing attrition to both bast and hurd fibers. This destructive action leads to a loss in fiber integrity. HempTrain™ is the most state-of-the-art, decortication and separation technology available - capable of separating baled hemp straw, round or square, fresh/green or dry, into high-volume, high-value products.

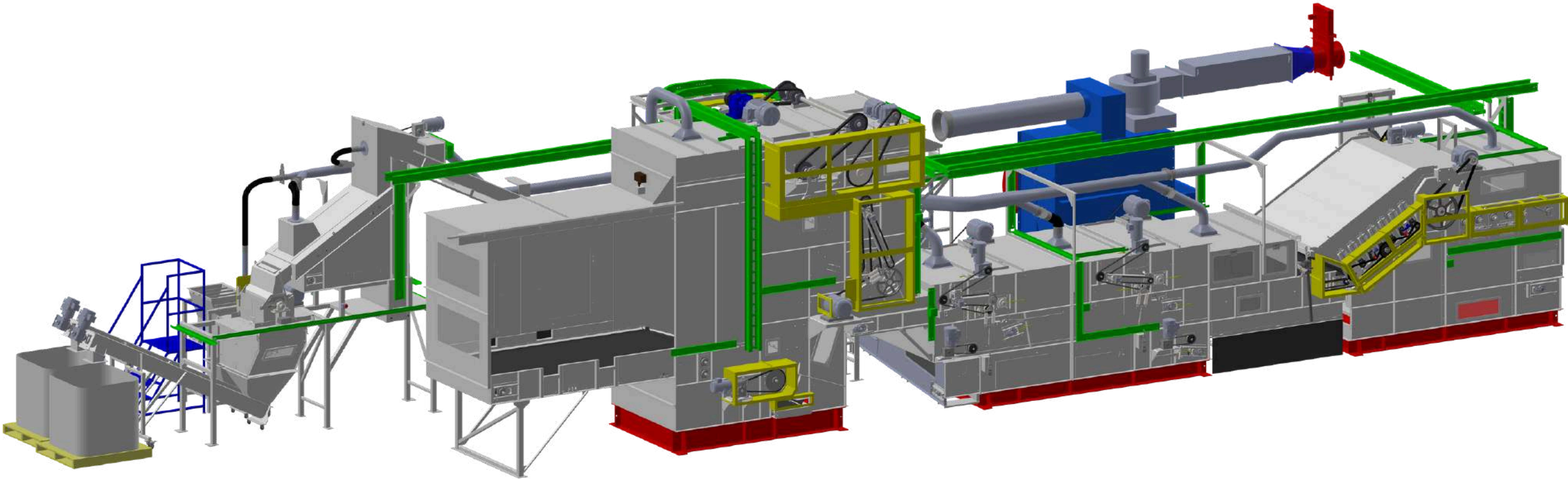

**STATE-OF-THE-ART
DECORTICATION AND
SEPARATION
TECHNOLOGY**



CONSUMER PRODUCT OFFERING



HEMP-FRESCO

Food preservation pads keep fruit and vegetables fresh for extended periods, preventing undesirable bacteria from spoiling food and keeping food smelling and tasting fresh for longer.



HEMPYCAT

Organic hemp pet litter is five times more absorbent and seven times lighter than clay. It is 99% percent dust-free, fragrance-free, environmentally friendly, and compostable.



HEMP ANIMAL BEDDING

Animal bedding is ultra-absorbent (three times more so than wood shavings), 99% dust free, and its natural deodorizer ensures natural odor control.



HEMP-PAK

Premium, organic soil enrichment made from hemp. It provides natural aeration to plants, decreasing compaction and providing plants with the nutrients they need to thrive. Rich in natural bio-nutrients including terpenes, lignin, hemicellulose, and pectin, it reduces the frequency of watering and combats evaporation in dry conditions.



HEMPZORB

All natural 100% premium hemp spill absorbent quickly contains spilled liquids. Hempzorb's unique, ultra-lightweight, ultra-absorbent formula is non-abrasive and will not scratch floors. No chemicals, sustainable and eco-friendly.



HEMPALTA GARDEN MULCH

Use in all types of gardens, landscapes, pathways, around trees, shrubs, flowers and vegetables. Conserves water, stabilizes soil, compostable & non-toxic.

GROWING RETAIL PARTNERS

Our consumer products are currently being sold and distributed in 150+ stores & through e-commerce platforms in Canada & the U.S with the goal of reaching 1,500+ retail channels.

IN-STORE



ONLINE



BIO-COMPOSITE BUILDING MATERIAL OPPORTUNITY & PLANT EXPANSION

U.S. BUILDING CODE APPROVAL OF HEMPCRETE SOLIDIFIES DEMAND FOR INDUSTRIAL HEMP

- U.S. RESIDENTIAL BUILDING CODE CHANGE IS IN EFFECT (2024) ALLOWS HEMP-LIME (HEMPCRETE) FOR ONE AND TWO-FAMILY DWELLINGS AND TOWNHOUSES IN 49 OF 50 U.S. STATES.¹
- POTENTIAL PLANT EXPANSION TO INCREASE PRODUCTION CAPACITY FROM THE CURRENT 10,000 ACRES PER YEAR TO BE CONSIDERED IN 2024/2025 TO MEET MARKET DEMAND.
- OUR PREMIUM HURD, PRODUCED BY THE STATE-OF-THE-ART HEMPTRAIN™ ADVANCED PROCESSING PLANT, IS IDEAL FOR HURD OR HEMPCRETE CONSTRUCTION APPLICATIONS AND THE COMPANY INTENDS TO FOCUS ON THIS PRODUCT AS PART OF 2024/2025 INITIATION.



HURD FOR HEMPCRETE



THE MATERIALS USED TO CREATE HEMPCRETE BIOCOMPOSITES ABSORB CO2 DURING THE CURING PROCESS. ADDITIONAL CO2 IS ABSORBED AND OFFSET DURING THE LIFECYCLE OF THE INDUSTRIAL HEMP PLANT WITH AN ESTIMATED 1.63 TONS OF CO2 REMOVED PER HEMP TON PRODUCED.²

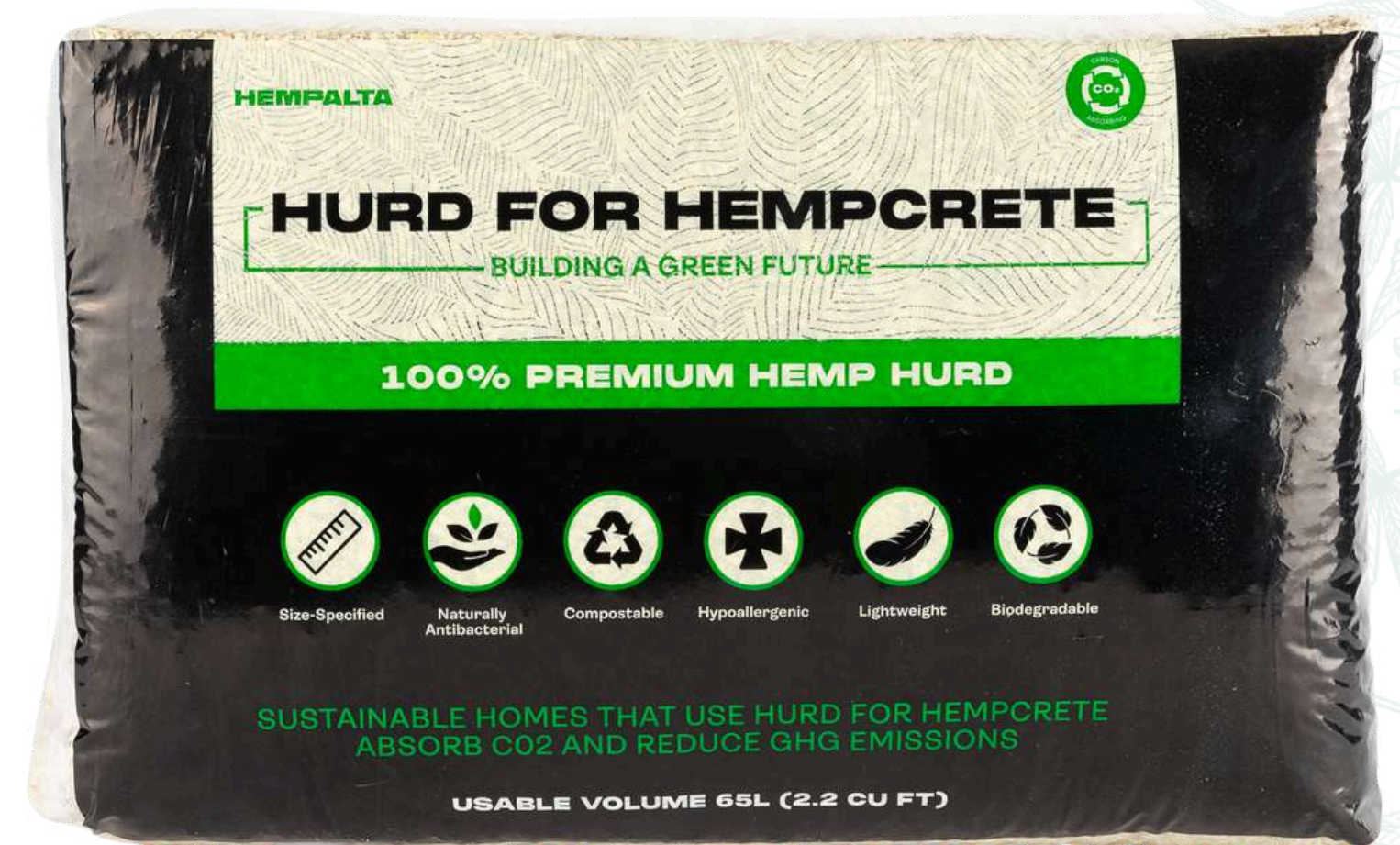

COMPETITIVE LANDSCAPE

COMPETITOR								
LOCATION		CANADA	CANADA	COLORADO	NEW YORK	CALIFORNIA	KENTUCKY	CALIFORNIA
CARBON REMOVAL CREDITS		✓	✗	✗	✗	✗	✗	✗
PROCESS BIOMASS INTO HIGH-VALUE PRODUCT		✓	✓	✓	✗	✗	✗	Yes- focus on hemp hurd and powdered hemp hurd
BRANDED VALUE-ADD CONSUMER PRODUCT RANGE	FOOD PRESERVATION	✓	No self-branded product range. Food, CBD and fiber products are produced for manufacturers who add value and/or package	✗	✗	✗	✗	✗
	PET LITTER/ANIMAL BEDDING	✓		✗	✓	✗	✗	✗
	ORGANIC SOIL AMENDMENT	✓		✗	✗	✗	✗	✗
	OTHER	Garden Mulch, HempZorb, and Hurd for Hempcrete		Construction and oil	CBD oils, CBD pet oils, and food snacks	Hemp fabric, hemp seed, hemp seed oil, Hempcrete, hemp webbing, hemp rope, yarn and twine	Hemp lumber and hemp flooring	None
B2B SALES		✓	✓	✓	✓	✓	✓	✓
B2C SALES		✓	✗	✓	✓	✓	✓	✓

HEMPALTA ROADMAP

OUR PLAN IS ANCHORED ON EXECUTING THE GO-TO-MARKET STRATEGY, EXPANDING OUR PLANT PROCESSING CAPACITY AND SUPPORTING HURD FOR HEMPCRETE PRODUCT EXTENSIONS TO SCALE THE OPERATION AND DISTRIBUTION.

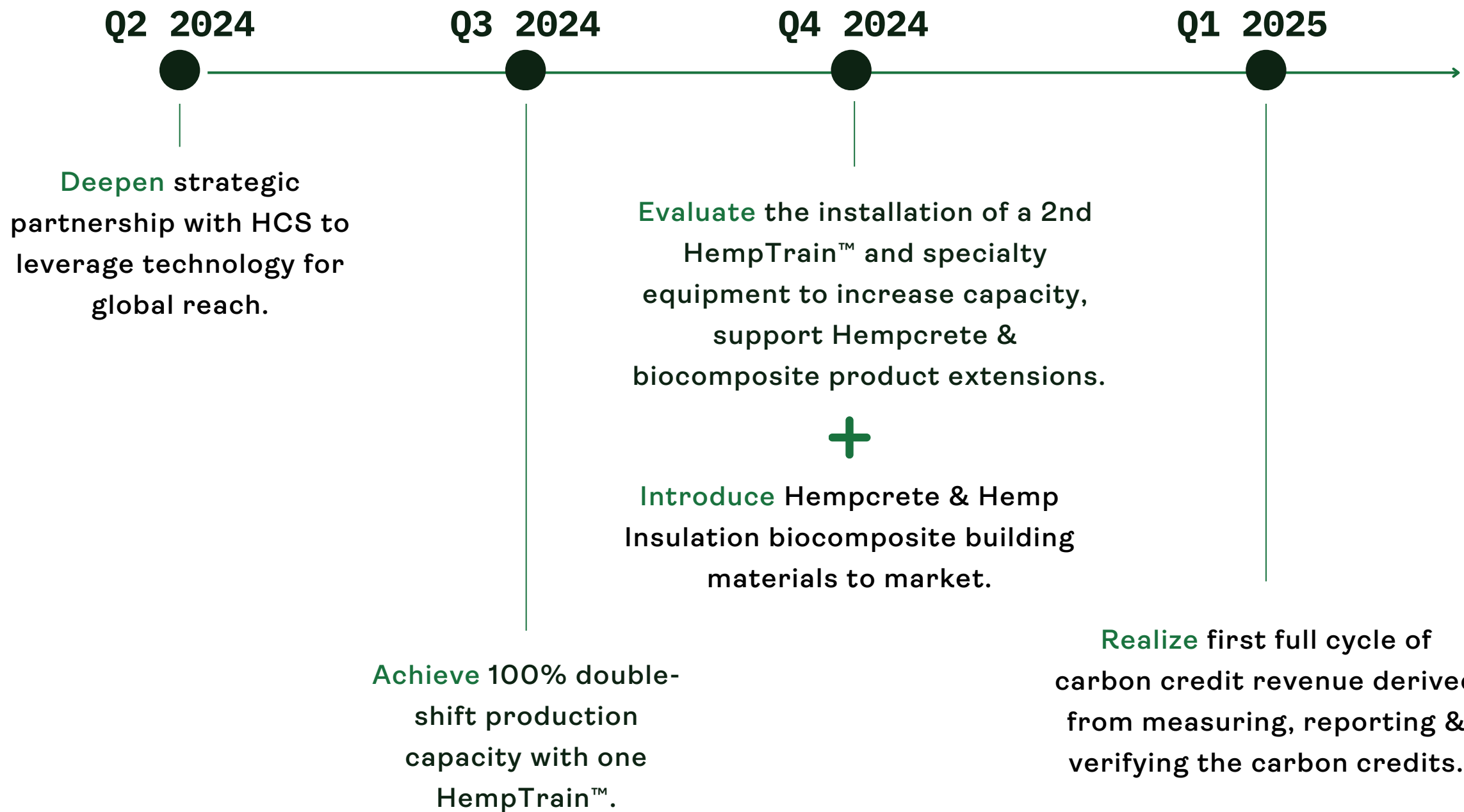

MANAGEMENT TEAM



DARREN BONDAR | PRESIDENT, CEO & DIRECTOR

- Professional entrepreneur with track record of success at private + public companies
- Founded, built and operated Spiritleaf, Canada's largest cannabis store network and, sold for \$131 million to major Canadian Licensed Producer in 2021
- 20+ years of experience driving business and financial performance



CANDACE RYAN | CFO

- 10+ years of accounting and finance experience, primarily in retail sector
- Previously held role of Financial Controller for a national retail brand startup
- CGA designation + CPA member



BRITTANY MCKELL | GENERAL MANAGER

- Manages production, logistics and procurement for Operations
- Experience in hemp industry includes roles in sales & marketing and product innovation
- Marketing degree from Mount Royal University + Business Admin. diploma from SAIT



SAMANTHA DOWN | MARKETING MANAGER

- Oversees sales & marketing activities
- Previously held marketing roles with two national consumer product retailers
- Business Admin. degree from Mount Royal University + Finance diploma from SAIT



PETE KNECHTEL | BUSINESS DEVELOPMENT MANAGER

- Handles business development, sales, client relations and partnerships
- Previous business development roles in the sports and construction industry
- BA from University of Alberta



CECIL HORWITZ | HEAD OF SUSTAINABILITY & CARBON CREDIT STRATEGY

- 20 + years of expertise in launching businesses, retail expansion, franchising, sales operations, merchandising, and marketing
- Exceptionally skilled at translating strategic visions into practical executions. Inspired by clear goals and metrics, with a strong focus on people, culture, and customer satisfaction

PRODUCTION TEAM



Alusine N'Jai
Production Supervisor



Damian Meahan
Operator



Martin Posadas
Operator



Rostyslav Levchenko
Operator



Joel Maghuyop
Operator



Anatolii Pylypchuk
Operator

BOARD OF DIRECTORS

FOUNDING TEAM INCLUDES SEASONED AND TESTED INDUSTRY VETERANS TO DRIVE STRATEGIC GROWTH.



DARREN BONDAR | PRESIDENT, CEO & DIRECTOR

- Serial entrepreneur with a track record of success with private + public companies
- Founded and built Spiritleaf, Canada's largest cannabis store network
- Founded and built a premium watch chain of boutiques across Canada
- MBA from University of Alberta



ADRIAN STOKES | DIRECTOR

- Manages a Private Family Office for the majority partner of Fullbrook Thorpe Investments LLP
- Board Observer for Rent Plus UK Ltd
- 20 years of experience in financial services, including with Barclays Wealth & Investment Management
- Holds a double major Business degree from Greenwich Business School



DAN BALABAN | DIRECTOR

- Entrepreneur with record of successful business ventures
- Executive Chair and CEO of Greengate, a leading Canadian renewable energy company
- Founded a software solutions provider to the energy industry
- Bachelor of Science in Computer Science from University of Toronto



CRAIG STEINBERG | DIRECTOR

- Multi-faceted professional working as a lawyer at Steinberg Law
- He has a history of leadership in the legal and finance industries, including a previous role as an associate and partner at Miller Thomson LLP.
- Prior Director of Inner Spirit Holdings Ltd.



RUSSELL WILSON | DIRECTOR

- Vice President of Business Development at Prairie Merchant Corporation, a private investment firm, since February 2019, showcasing his leadership in fostering growth and development within the company.



MICHAEL GINEVSKY | CORPORATE SECRETARY

- Partner at DS Lawyers Canada LLP focused on capital markets, M&A, corporate governance, and securities regulatory compliance
- Bachelor of Commerce from UBC and Juris Doctor from the University of Alberta

ADVISORS



ACCOUNTING
GEIB & COMPANY



LEGAL
DS LAWYERS CANADA LLP



INVESTOR RELATIONS
IRLABS INC.



TECHNICAL ADVISOR
CANADIAN GREENFIELD TECHNOLOGIES

OUR COMMITTED SHAREHOLDERS

BRINGING HEMPALTA TO LIFE HAS TAKEN GREAT **PASSION** AND A GREAT TEAM. STRONG **RELATIONSHIPS** WITH OUR SHAREHOLDERS HAVE BEEN VITAL.



INVESTOR INFORMATION

Hempalita Corp.

CAPITALIZATION TABLE

MAY 5, 2024

SHARES ISSUED & OUTSTANDING	94,944,176
WARRANTS	2,784,823
OPTIONS	7,052,941
FULLY DILUTED	105,781,940

HIGHLIGHTS

- The industrial hemp industry is projected to experience growth as consumers and companies seek environmental and sustainable products.
- The strategic partnership with HCS can result could result in thousands of acres of industrial hemp being measured reported and verified.
- The market for carbon credits, including those from industrial hemp, is expected to grow as environmental concerns intensify, presenting unique opportunities for nature-based carbon removal credits.
- Hemp building materials were officially approved in the U.S. residential building code in 49 of 50 U.S. states. It applies to one and two-family dwellings and townhouses.





THANK YOU!

BOOK A MEETING



FOLLOW US



For more information, please contact:

Darren Bondar, President & CEO

invest@hempalta.com

HEMPALTA