

OLG



---

## Balance Chair

Assembly Instructions

# Balance Chair

## Components List

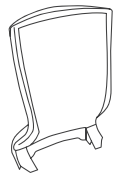

Back Frame

A



Left Arm

B



Right Arm

C



Seat Pan

D



Gas Cylinder

E



Base

F



5 x Caster

G



Hex Wrench

H



4 x Short Bolt

J



2 x Long Bolt

K

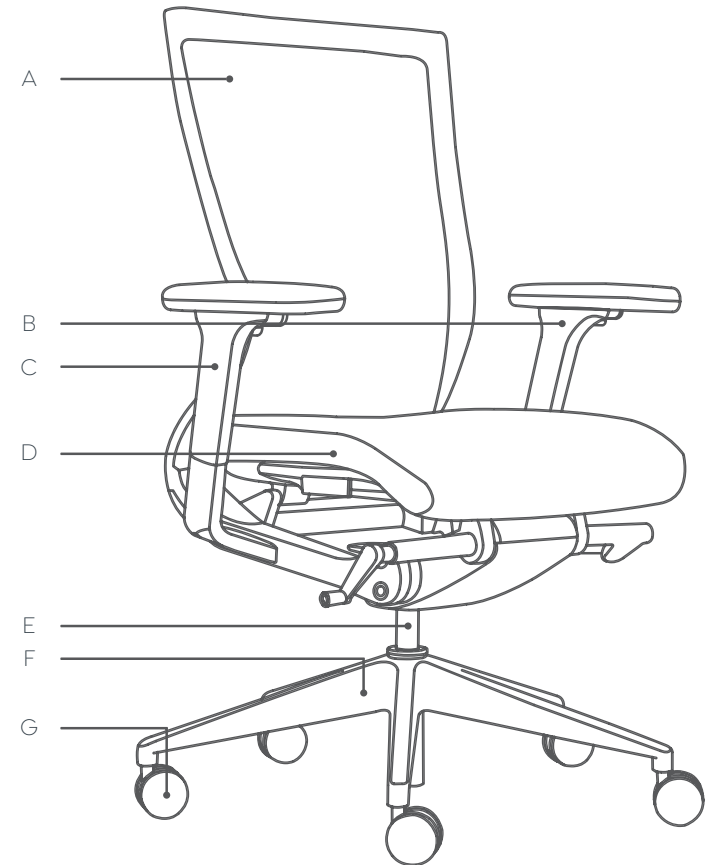

### STEP 1:

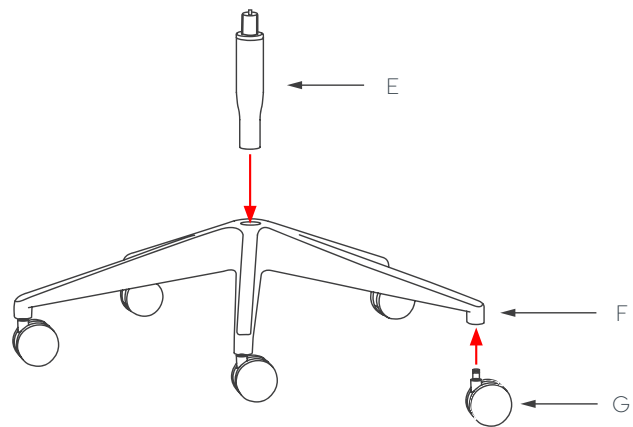

### STEP 2:

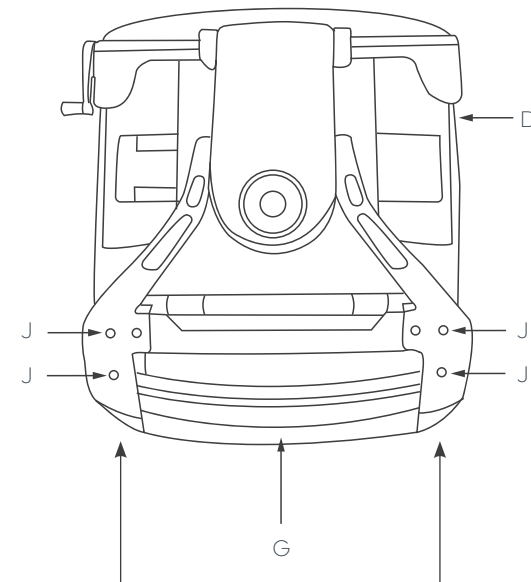

Align back frame mounting holes on both sides.

# Balance Chair

## Assembly Instructions

### STEP 3:

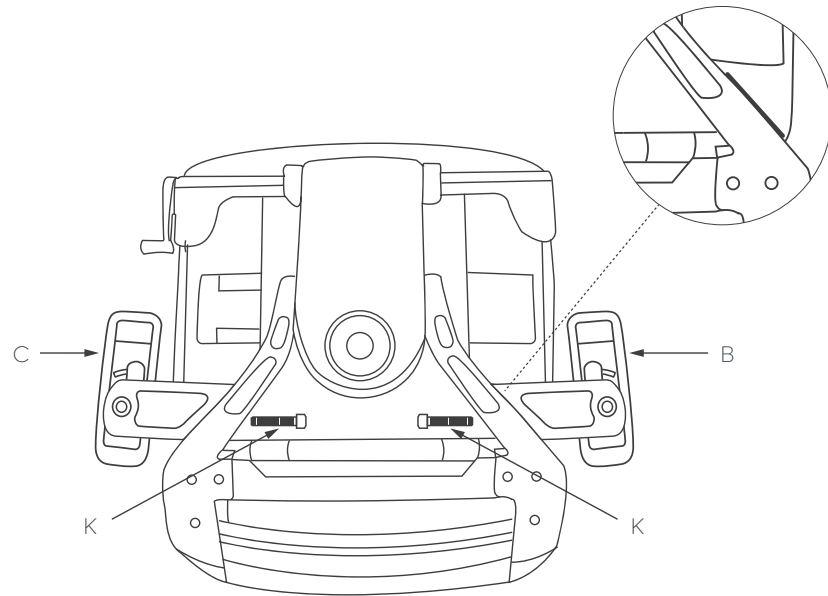

### STEP 4:

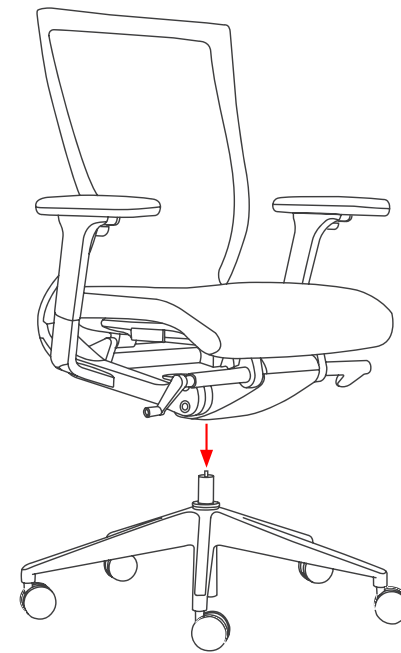

## Slip Cover (sold separately)



1. Assemble chair

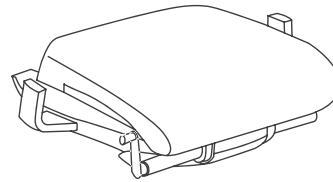

2. Remove old slip cover and foam from seatpan by unfastening the velcro fasteners on the back and front of seat. Remove the back fasteners first.

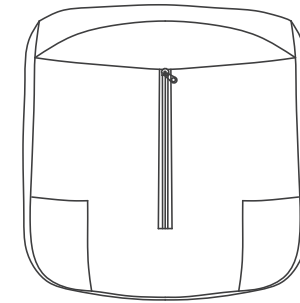

3. Unzip old slip cover and remove from foam.

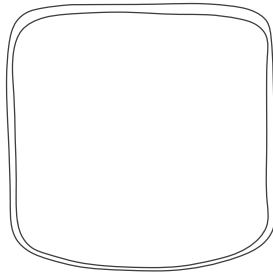

5. Install new slip cover onto the foam.

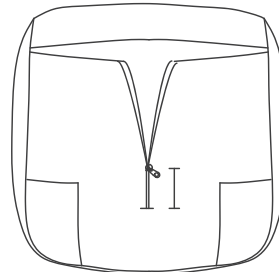

5. Make sure all four slip cover corners match to the foam corners, top & bottom. Close zipper approximately 2"

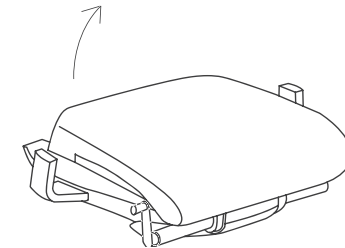

6. Align 2 front corners and install using velcro fasteners. Lift back of seat and zip up slip cover. Align 2 back corners and install using velcro fasteners.



**Sydney** 02 8188 2732

**Melbourne** 03 9111 0315

**Brisbane** 07 3733 1923

**Adelaide** 08 7111 0810

**Perth** 08 9468 2707

[info@olgoffice.com](mailto:info@olgoffice.com)

[myolg.online](http://myolg.online) | [olgoffice.com](http://olgoffice.com) | [officedesigner.net](http://officedesigner.net) | [motionoffice.com](http://motionoffice.com)