



Overview

The ExpertPower LiFePO4 12V 50Ah rechargeable battery is optimized for low rate applications which require high energy density.

Features

- High energy density
- Automatic protection with internal battery management system
- Low self-discharge rate
- Long cycle life
- Excellent performance in all operating temperatures
- 4 batteries in series or parallel

Battery Dimensions:

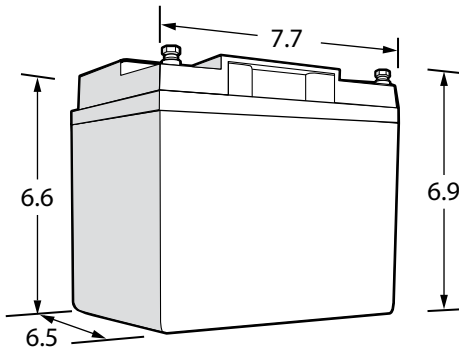

Battery Specifications:

NOMINAL CHARACTERISTICS	
Nominal Voltage / V	12.8V
Nominal Capacity /Ah (77°F, 0.2C)	≥ 50Ah
MECHANICAL CHARACTERISTICS	
Weight	11.05 lbs
Dimensions L x W x H	7.7 x 6.5 x 6.6 in
BCI	-
Terminal	M5
ELECTRICAL CHARACTERISTICS	
Voltage Window	9.2 – 14.6V
Charge Voltage	14.4V
Standby Voltage	13.8V
Max. Continue Discharge Current	50A
Max. Permanent Discharge Current	100A 5Sec.
Recommend Max. Continue Charge Current	25A
OPERATION CONDITIONS	
Cycle Life (68°F 0.2C 100%DOD)	>2500 Cycles
Operating Temperature	Discharge: - 4 – 140°F Charge: 32 – 140°F
Storage Temperature	32 – 86°F
Storage Duration	12 Months at 77°F
Safety Standard	UL1642 at cell level

Terminal Dimensions:

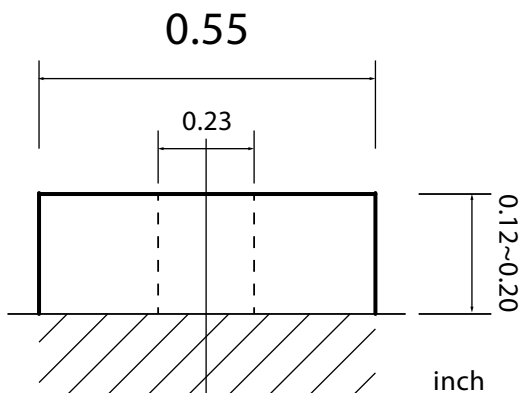

BMS Parameters

TYPE		FUNCTION	SETTING VALUE	RECOVERY
Over-Voltage		Cell Voltage Protection	$>3.75 \pm 0.05V$	Delay $2.0 \pm 0.3S$; Cell Voltage $\leq 3.5 \pm 0.5V$
Under-Voltage		Cell Voltage Protection	$<2.5 \pm 0.05V$	Delay $2.0 \pm 0.3S$; Cell Voltage $\geq 2.7 \pm 0.5V$
Current	Charge	Over-Current Protection 1	$>75 \pm 10A$	Disconnect Charger Auto Recover in 10S
		Delay	3S	
	Discharge	Over-Current Protection 2	$>100 \pm 10A$	
		Delay	2S	
	Discharge	Over-Current Protection 1	$>100 \pm 10A$	
		Delay	2S	
Temperature	Battery	Charge: $>145 \pm 5^\circ F$ or $< 32 \pm 5^\circ F$	Delay $2.0S \pm 0.5S$	$< 113 \pm 5^\circ F$ and $> 41 \pm 5^\circ F$
		Discharge: $>149 \pm 5^\circ F$ or $< -4 \pm 5^\circ F$		$< 131 \pm 5^\circ F$ and $> 14 \pm 5^\circ F$
	BMS	$>185 \pm 5^\circ F$		$<158 \pm 5^\circ F$
Cell Balance		Balancing Voltage		$3.50 \pm 0.05V$
		Balancing Current		$100 \pm 20mA$
Short Circuit		250A - 350A	$\leq 500\mu S$	Disconnect Load Auto Recover in 15S

Battery Attributes

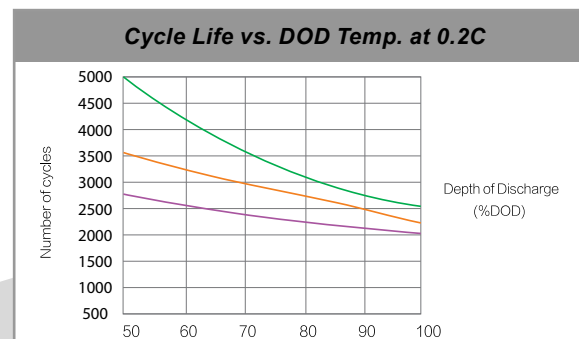
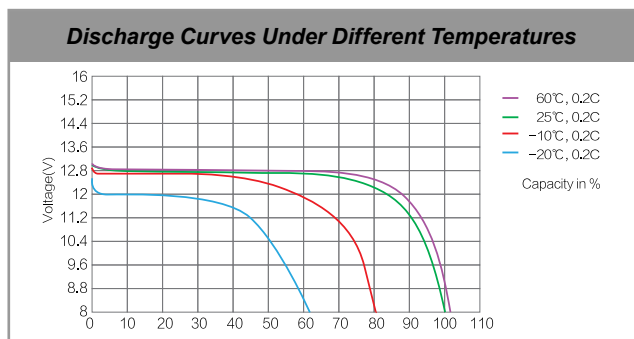

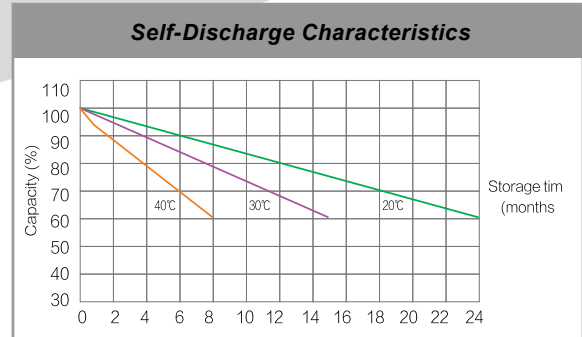
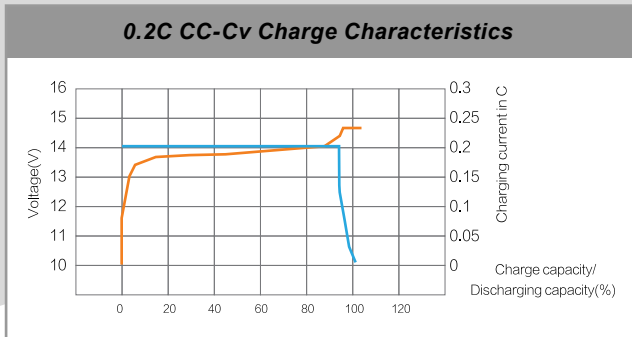

Series & Parallel Connection

Supports expansion up to 4 batteries sequenced in either series at 48V 50Ah, or in parallel at 12V 200Ah.

When wiring sequenced batteries: DO NOT connect both negative and positive wires from your electrical system to just one single battery or connect them to batteries in the center of your sequence.

When sequencing wiring multiple batteries together in either parallel or series, it is important to remember that your sequenced batteries need to be wired to your electrical system in such a way that the negative and positive wires from your system connect to the battery bank via the first and the last batteries in the sequence. For instance, the first battery in your sequence might have the negative wire of your system connected to the negative terminal and the last battery in your sequence will have the positive wire of your system connected to the positive terminal of that battery.

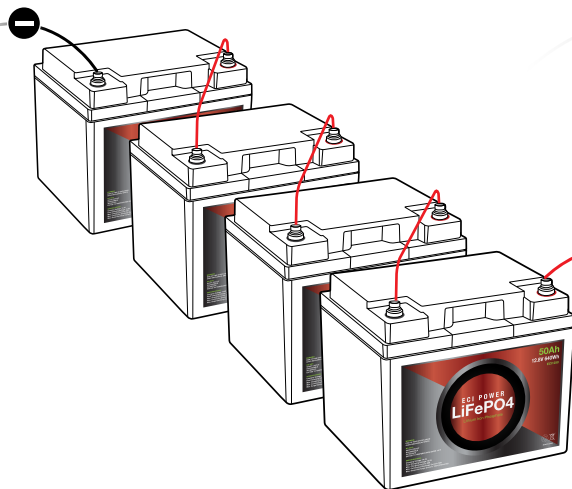

4 In Series - 48V 50Ah

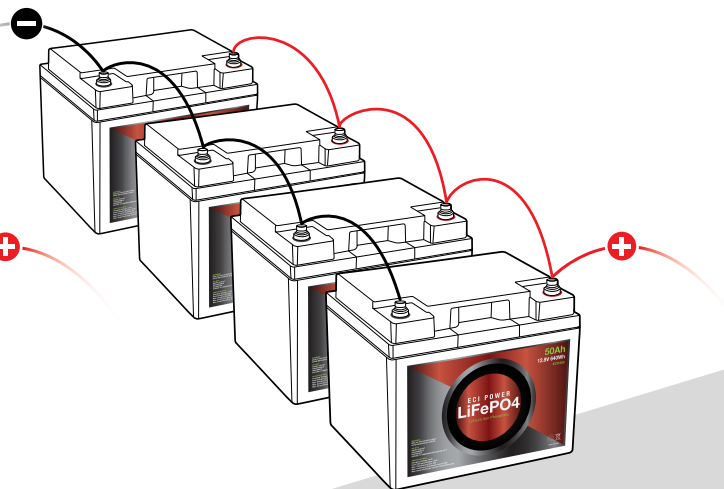

4 In Parallel - 12V 200Ah

CAUTION

1. Use identical batteries to connect in parallel or in series.
2. Ensure all batteries have the same voltage level by fully charging each battery prior to connecting in parallel or series. (Voltage difference $<0.2V$)
3. DO NOT mix old and new batteries.
4. DO NOT connect the batteries in parallel AND series at the same time.
5. DO NOT connect more than 4 batteries per circuit.
6. Once a year, the batteries should be removed from string and individually charged. The voltage difference upon reassembly should be no more than 0.5V.

Battery Charging

LiFePO4 Batteries perform a 2-stage charging algorithm called "Constant Current/Constant Voltage" (CC/CV). The standard LiFePO4 profile is 0.2C CC charge to 14.2V, and then, CV at 14.4V charge until the charge current declines to $\leq 0.05C$.

The recommended max. charging current for a 50Ah LiFePO4 battery is 25A. A faster charge of 50A (1C) may be used as necessary, however, regularly charging your battery this way may shorten its life and subsequently its total capacity due to the extra heat generated during this process.

We do not recommend using any other types of chargers for LiFePO4 batteries, such as SLA and Gel chargers. Those chargers are designed specifically for acid-based battery chemistry and normally come with desulfation, equalization, and float charging features, all of which are harmful for LiFePO4 batteries. Furthermore, irreparable damage can occur despite the built-in BMS as this safety system can't protect a LiFePO4 battery from an SLA charger. This occurs because keeping a LiFePO4 battery at 100% by using the SLA float charging feature will not trigger any preset protection parameters, unfortunately, in the long term, this will greatly accelerate aging and degradation in the battery's cells as their activity is constantly stimulated due to the extra power coming from the SLA charger. This extra stimulation leads to polarization (buildup of material where the electrodes make contact with the electrolyte) as well as electrolyte decay.

Using an SLA charger with an OCV (Open-Circuit Voltage) detection setting may not only damage the battery as stated previously but it may also fail to wake up an over-discharged LiFePO4 battery. Beware that the BMS in LiFePO4 batteries will halt battery function this will effectively deactivate the battery to protect it from any damage contingent with over-discharge, over-current, and other protection parameters. In this deactivated state, the battery voltage is set to 0V in an effort to prevent it from being charged and discharged. The 0V will often be interpreted as an open circuit by SLA chargers, so it will often refuse to perform charging and or activate the battery.

It's necessary to use the correct charging algorithm (CC/CV; 14.4V) as SLA smart chargers will never fully charge a LiFePO4 battery or charge it adequately enough to provide maximum lifespan and efficiency.

Warnings:

1. Do not immerse the battery in water or allow it to get wet.
2. Do not use or store the battery near sources of heat such as a fire or heater.
3. Do not reverse the positive (+) and negative (-) terminals.
4. Do not connect the battery directly to wall outlets or car cigarette-lighter sockets without proper charging equipment. Do not allow exposed ends of cables connected to opposite terminals to touch.
5. Do not put the battery into a fire or apply direct heat.
6. Do not use the battery if the battery casing has been pierced, broken, cracked, or otherwise visibly damaged. Do not forcibly open the battery casing for any reason.
7. Avoid severe physical shock. Do not throw the battery or heavily strike the battery in any way. Do not put excessive pressure or step on the battery.
8. Never solder anything directly to the battery terminals.
9. Do not attempt to disassemble or modify the battery in any way.
10. Do not place the battery in a microwave oven or pressurized container.

Usage and Storage:

1. Before use, inspect battery to ensure that there is no visible damage or structural deformities.
2. **DO NOT USE** if terminals are bent or broken, battery is abnormally hot prior to use, wet or if the box it came in appears to have severe physical or water damage that has extended on to the battery, leaking, loose, casing is cracked, bloated, melted, heavily stressed, and or indented. If the battery is exhibiting any of these issues or if you suspect the integrity of the battery has been compromised immediately contact our support team for further assistance.
3. To ensure proper performance and prevent damage or malfunctions, it is highly recommended that these battery packs be installed by a professional or experienced individual. Be sure to monitor battery packs when charging for the first time and also when using (discharging) for the first time. Monitor temperature and performance for any physical or internal operation discrepancies. For operation issues contact support.
4. The battery pack should be stored in a cool, dry and well-ventilated area, and should never be stacked under heavy objects, be exposed to open flame, high temperatures, or corrosive materials.
5. The battery should be stored in the proper specified temperature conditions. Recommended Storage humidity is 60±15%.
6. Store battery at 40% - 60% capacity. Every three months in storage, it is recommended to charge the battery fully, then discharge it fully, and finally recharge the battery back to 40% - 60% capacity again to avoid over-discharge during storage.

Terms and Conditions:

Please read all specifications, usage, storage conditions, and warnings on this document before use. Always adhere to our handling and usage directions for this battery pack. Misuse of batteries can cause the battery to malfunction, degrade and reduce its capacity or life expectancy, overheat, explode, or become a fire hazard. Customers are responsible for the proper use and storage of this battery pack which is outlined on this document. If at any point, the battery excessively overheats, leaks, etc, or does not function as stated, or is visibly damaged; **DO NOT USE.** Please contact our support team for further assistance. **We do not bear responsibility for any damages caused by the misuse of this battery accidental or otherwise.**