



# 35L Oil Control Valve Instruction Manual

---



## **WARNING:**

Read carefully and understand all **INSTRUCTIONS** before operating. Failure to follow the safety rules and other basic safety precautions may result in serious personal injury. Save these instructions in a safe place and on hand so that they can be read when required. Keep these instructions to assist in future servicing.

---



## GENERAL SAFETY REGULATIONS



**WARNING:** The warnings, cautions, and instructions discussed in this instruction manual cannot cover all possible conditions or situations that could occur. It must be understood by the operator that common sense and caution are factors that cannot be built into this product, but must be supplied by the operator.

1. Keep the work area clean and dry. Damp or wet work areas can result in injury.
2. Keep children away from work area. Do not allow children to handle this product.
3. Use the right tool for the job. Do not attempt to force small equipment to do the work of larger industrial equipment. There are certain applications for which this equipment was designed. It will do the job better and more safely at the capacity for which it was intended. Do not modify this equipment, and do not use this equipment for a purpose for which it was not intended.
4. Check for damaged parts. Before using this product, carefully check that it will operate properly and perform its intended function. Check for damaged parts and any other conditions that may affect the operation of this product. Replace damaged or worn parts immediately.
5. Do not overreach. Keep proper footing and balance at all times to prevent tripping, falling, back injury, etc.
6. DO NOT use the equipment when tired or under the influence of drugs, alcohol, or medication. A moment of inattention while operating this equipment may result in serious personal injury.

## TECHNICAL DETAILS

Item No.	OCVF-001
Inlet Connection	1/2" NPT(F)
Fluid Range	1 ~ 35L/M(0.3~9.25gpm)
Pressure Range	5-50Bar / 70-725psi
Temperature	Min. -10°C Max. 60°C
Precision	±0.5%
Viscosity	8-5000mps
Power Source	1x3V CR2 battery
Rigid Tube	—
Flexible Hose	■
Manual Tip	—
Automatic Tip	■
Digital Meter	■

## INSTALLATION

- Control valve is 1/2" oil inlet, when connecting with hose fitting, please remember to apply the Teflon or for sealant better seal.

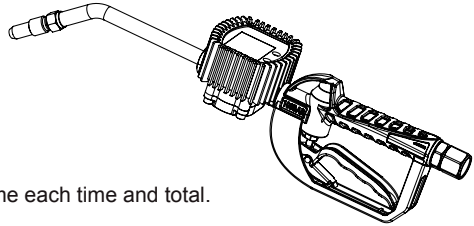

## METER

- 5-digit liquid crystal display for both volume each time and total.
- 4 units: L, GAL, PT and QT.
- Accurate to the second decimal place.
- Low battery indicator.
- 2 buttons: "Move", "Reset".

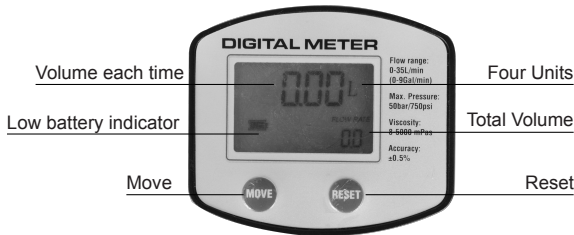

**Attn: Do not apply the meter as a measuring tool for commercial trading**

## DETAILS OF OPERATION

### 1. BEFORE PUTTING INTO OPERATION

- Check the technical data of the installation match with those of the lube meter. For example connections, pressure, flow range and medium. Use the formula: Proper correction factor = (actual value / displayed value) x current correction factor to decide the right connection factor, then set the proper correction factor (refer to 3. Button usage part).
- Once the meter has been installed, please make sure that no air pressure shocks or particles can damage the meter.
- Please check all connections to avoid leakage.

## 2. CHANGE THE BATTERY

- Battery type: Lithium CR2, 3V/1400mAh.
- Change the battery like below when the battery signal is flashing on the display.
- Remove the protector cover, unscrewing the screw.
- Change the battery and screw the lid on again.

## USER BUTTONS

The turbine digital meter features two buttons (MOVE and RESET) which individually perform two main functions and together, other secondary functions.

The main functions performed are:

For the reset key, resetting the partial Register and reset table total (reset total).

For the move key, entering instrument calibration mode.

Used together, the two keys permit entering configuration mode,

## BATTERY REPLACEMENT

When replacing the battery, please open the cover, remove the plug and replace the battery.

## LCD DISPLAY

### KEY

- ① Partial register (5 figures with moving comma from 0.1 to 99999)

Indicating the volume dispensed since the reset button was last pressed.

- ② Indication of battery charge

- ③ Indication of calibration mode

- ④ Indication of resetting present total to Zero

- ⑤ Total register

- ⑥ Indication of flow rate mode

- ⑦ Indication of unit of measurement of partial: L = Litres

GAL = Gallons

PT = Pints

QT = Quarts

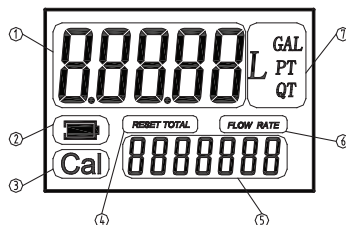

## DAILY USE

### BUTTON USAGE, CALIBRATION AND MEASUREMENT UNIT CHANGE

- **Reset the present total (See Fig. 4)**

- 1) When the meter is on standby, press the RESET key.
- 2) The display shows all the segments.
- 3) The meter resets the present total already.

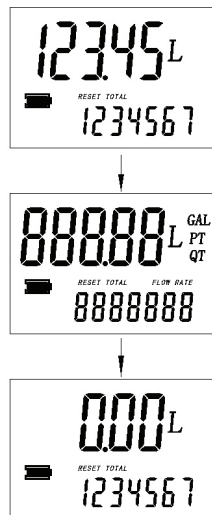

Fig. 4

- **Show current correction factor and general total (See Fig. 5)**

Press MOVE and RESET together and hold for less than 3 seconds. Value "1.4000" is the correction factor which can be reset; "1234567" is the general total which cannot be reset.



Fig. 5

- **Measurement unit change (See Fig. 6)**

Press MOVE and RESET together and hold for more than 3 seconds.

Zone 7 on the display is the current unit. Press RESET to chose a different measurement unit and then press MOVE and hold for more than 3 seconds to confirm.

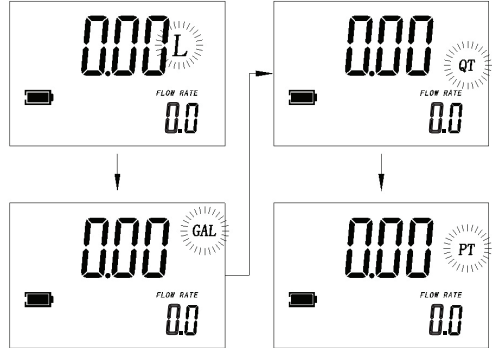

Fig. 6

- **Reset The Resettable Total (See Fig. 7)**

When the meter is on standby, press the RESET key for more than 3 seconds to reset the present total first.

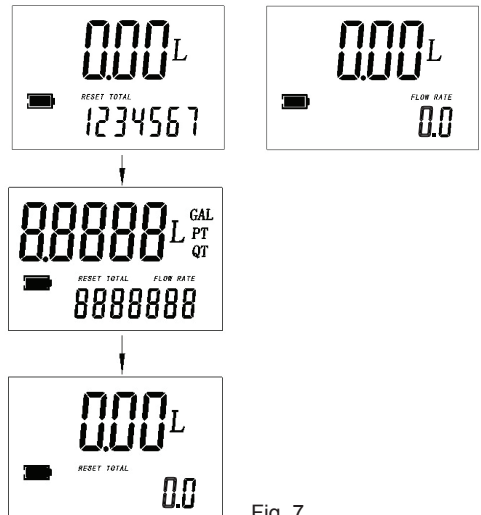

Fig. 7

## PROCEDURE FOR ENTER THE CORRECTION FACTOR DIRECTLY

Carefully follow the procedure indicated below.

## FORMULA

**Proper correction factor = current correction factor × (actual value / display value)**



Example:

Actual value            20.75

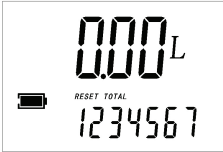

Display value           18.96

Current correction factor   1.000

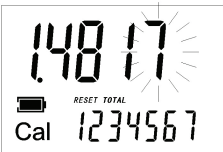
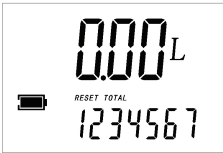
Proper correction factor   1.000 × (20.75 / 18.96) = 1.000 × 1.094 = 1.094

1	Wait for the meter to go standby.	
2	Reset the resettable total.	
3	Press the MOVE key. Keep it pressed until it shows similar to the right image (the digit flash in ① zone), which means the meter is under the calibration mode.	
4	Press the RESET key to choose the right digit from 0 to 9. Press the MOVE key to start the next digit. So the digit of correction factor can be changed one by one.	
5	Make sure the correction factor is right, press the MOVE key. Keep it pressed until the indication of calibration mode quits and the factor is saved.	

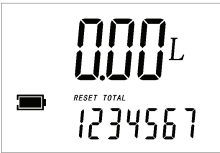
**MODIFY THE CORRECTION FACTOR IN FIELD**  
**PLEASE CAREFULLY FOLLOW THE PROCEDURE INDICATED BELOW.**

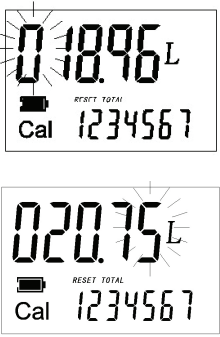
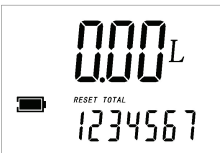
1	Wait for the meter to go standby.	
2	Reset the resettable total.	
3	Start dispensing into a measuring glass. Stop dispensing when over 5 Litres of volume is reached, read out the actual value. The volume that is displayed on the LCD is the Display Value, not the Actual Value which may be slightly higher. For example, in the figure on the right, the Display Value is 18.96 while the Actual Value is 20.75.	
4	Press the MOVE key. Keep it pressed until it shows as the right fig., with the digit flashing in ① zone. Press the MOVE key to go the the next digit so that the Actual Value can be input.	
5	Make sure the correction factor is right and then press the MOVE key. Keep it pressed until calibration is finished and the factor is save. The meter will then return to to be on standby.	

**USAGE INSTRUCTION**

**(1) Start:**

Turn on the trigger to make the oil transmission.

**(2) Keep the status:**

Push the lock ahead, then the transmission can be kept when the trigger is released.

**(3) Finish:**

a. If the lock is not used, release your hand, the trigger will turn off and finish the transmission.

b. If the lock is used, please turn on the trigger once again, the lock will stop working. Then turn off the trigger, release your hand, the transmission will be finished.

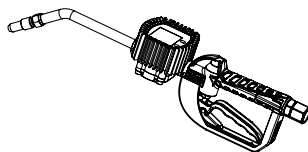
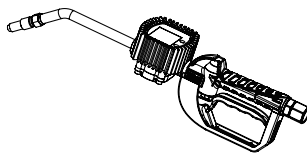

**Notes When Using:**

**Cautions:**

1. For working condition, please refer to the specification parameter list. Temperature: -10°C~60°C.
2. Media: Lubricant Oil.

**OIL CONTROL VALVE EXPLODED DRAWING**

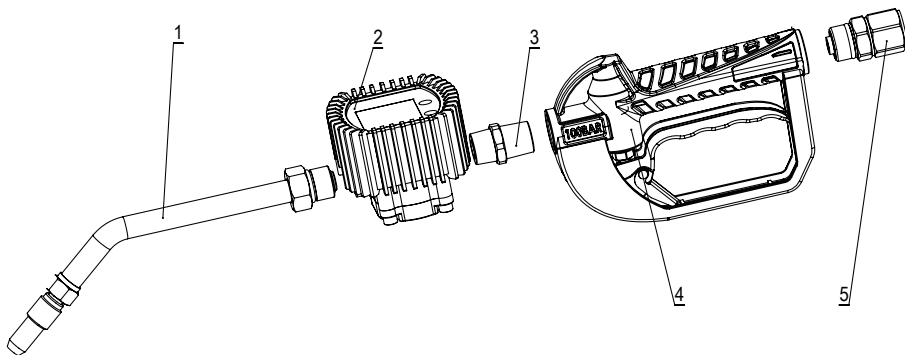

Part No.	Description	Q'ty	Part No.	Description	Q'ty
1*	Spout	1	4	Handle Body	1
2□	Meter	1	5	Swivel Fitting	1
3□	Adapter	1			

Note: □ digital oil control valve part. \* wearing part.

**MAINTENANCE**

If any problem, please contact your local service centre.



## TRUBLE SHOOTING GUIDE

Relieve the pressure before you check or repair the dispensing valve. Be sure all other valves and controls and the pump are operating properly.

To reduce the risk of serious injury whenever you are instructed to relieve pressure, always follow the pressure relief procedure on page 3.

Problem	Problem	Solution
Slow or no fluid flow	Filter is clogged, or pump pressure is low, or shut-off valve is not fully open, or foreign materials jammed in the metering element.	<ol style="list-style-type: none"> <li>1. Relieve the pressure.</li> <li>2. Loose swivel fitting, clean or replace the filter.</li> <li>3. If the problem remains, contact your distributor for repair or replacement.</li> </ol>
Oil leaks from swivel	Swivel is loose	Torque the swivel. If the problem remains, contact your distributor for repair or replacement.
	O-ring is worn or damaged	Replace the o-ring. If the problem remains, contact your distributor for repair or replacement.
Oil drips from nozzle	Nozzle is damaged or obstructed	Inspect the nozzle for damage or obstructions, and replace if damaged. If the problem remains, contact your distributor for repair or replacement.
Valve leaks	O-rings or valve seat are worn or damaged	Replace the o-rings and/or the valve seat. If the problem remains, contact your distributor for repair or replacement.
Leakage from meter	O-ring damaged	<ol style="list-style-type: none"> <li>1. Get the meter off from the dispense system.</li> <li>2. Take off the protector.</li> <li>3. Loosing four the socket head cap screws on the cover of the meter.</li> <li>4. Loosing eight the hex bolts on the bottom of the meter.</li> <li>5. Take off the seat.</li> <li>6. Check the o-ring, replacing the o-ring if it is damaged.</li> <li>7. After replacing the o-ring, assemble the meter and fix it back to the dispense system.</li> </ol>
No Display	Loosing Battery	<ol style="list-style-type: none"> <li>1. Get the meter off from the dispense system</li> <li>2. Take off the protector.</li> <li>3. Take off the labels sticks on the bottom of the meter.</li> <li>4. Loosing the five socket head cap screws on the bottom of the meter.</li> <li>5. Take off the seat.</li> <li>6. Check the battery, replacing the battery if it is out of power.</li> <li>7. After replacing the battery, assemble the meter and fix it back to the dispense system.</li> </ol>
	Battery out of power	
Wrong Reading	Correction coefficient error	Reset the correction factor (follow the instructions on Page 6).



**WARNING:** Your risk from these exposures varies, depending on how often you do this type of work. To reduce your exposure to these chemicals: work in a well ventilated area, and work with approved safety equipment, such as those dust masks that are specially designed to filter out microscopic particles.

## LIMITED WARRANTY

1. Macnaught warrants this product against defects in material and craftsmanship, for a period of 3 years from date of purchase, but not including wearing parts.
2. Macnaught's liability is limited to replacement or repair of defective material within the warranty period, when returned freight prepaid to the distributor or their designated service depot.
3. The warranty does not cover damage caused by accident, misuse or faulty installation.
4. The product must be installed and maintained in compliance with the instructions.

## EXPLODED AND PARTS LIST METER

Part No.	Description	Q'ty
2-1	Rubber Protector	1
2-2	Meter Cover	1
2-3	Main Circuit Board	1
2-4	Fix Board	1
2-5	Seat	1
2-6	Magnetic Rod	2
2-7	Oval Gear	2
2-8	O-ring	1
2-9	Meter Holder	1
2-10	Screw	4
2-11	Label	1
2-12	Screw	4
2-13*	Battery	1
2-14	Battery Cover	1
2-15	Screw	4
2-16	Screw	4
2-17	Shaft	2

\* Wearing Parts.

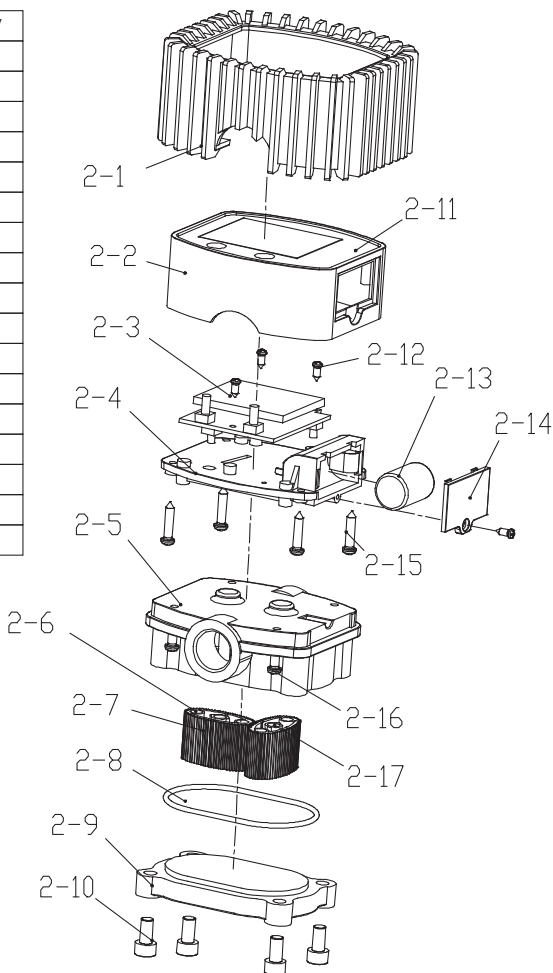

**EXPLODED AND PARTS LIST  
VALVE BODY EXPLODED DRAWING**

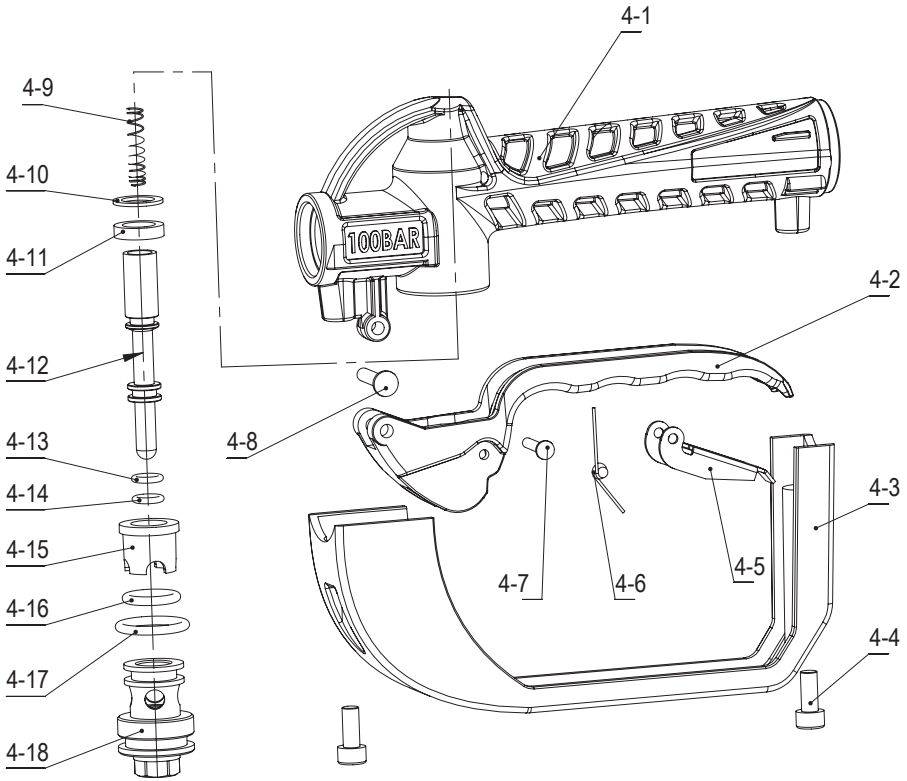

Part No.	Description	Q'ty	Part No.	Description	Q'ty
4-1	Handle Body	1	4-10*	Washer	1
4-2	Trigger	1	4-11*	Seal	1
4-3	Grip	1	4-12	Slip Pole	1
4-4	Screw	2	4-13*	O Ring	1
4-5	Trigger Lock	1	4-14*	O Ring	1
4-6	Clip	1	4-15	Bushing	1
4-7	Pin	1	4-16	O Ring	1
4-8	Pin	1	4-17	O Ring	1
4-9	Spring	1	4-18	Piston Sleeve	1

\* Wearing Parts.



**Macnaught Americas**  
**(813) 628-5506 | [info@macnaughtusa.com](mailto:info@macnaughtusa.com)**

\* Read Manual Before Use!