



Heavy Duty Grease Pump Instruction Manual



WARNING:

Read carefully and understand all **INSTRUCTIONS** before operating. Failure to follow the safety rules and other basic safety precautions may result in serious personal injury. Save these instructions in a safe place and on hand so that they can be read when required. Keep these instructions to assist in future servicing.



GENERAL SAFETY REGULATIONS



WARNING: The warnings, cautions, and instructions discussed in this instruction manual cannot cover all possible conditions or situations that could occur. It must be understood by the operator that common sense and caution are factors that cannot be built into this product, but must be supplied by the operator.

1. Keep the work area clean and dry. Damp or wet work areas can result in injury.
2. Keep children away from work area. Do not allow children to handle this product.
3. Use the right tool for the job. Do not attempt to force small equipment to do the work of larger industrial equipment. There are certain applications for which this equipment was designed. It will do the job better and more safely at the capacity for which it was intended. Do not modify this equipment, and do not use this equipment for a purpose for which it was not intended.
4. Check for damaged parts. Before using this product, carefully check that it will operate properly and perform its intended function. Check for damaged parts and any other conditions that may affect the operation of this product. Replace damaged or worn parts immediately.
5. Do not overreach. Keep proper footing and balance at all times to prevent tripping, falling, back injury, etc.
6. DO NOT use the equipment when tired or under the influence of drugs, alcohol, or medication. A moment of inattention while operating this equipment may result in serious personal injury.



WARNING SYMBOL: This manual contains important warnings and information. Read and keep for reference.



CAUTION SYMBOL: This symbol alerts you to the possibility of serious injury or death if you do not follow the instructions.



CAUTION: This symbol alerts you to the possibility of damage to or destruction of equipment if you do not follow the instructions.

TECHNICAL DETAILS

Pneumatic Grease Pumps Technical Data:

Item No.	GP6075-1-001	GP40075-1-001
Length of suction tube	480mm / 19"	940mm / 37"
Air inlet	1/4" NPT	
Pressure Ratio	75:1	
Air Inlet Working Pressure	5-10bar / 70-145psi	
Max. Air Inlet Pressure	12bar / 175psi	
Max. Grease Outlet Pressure	900bar / 1305psi	
Air Motor Effective Diameter	76mm / 3"	
Max. Free Flow Rate	1600g/min. / 3.5lbs/min.	

SUMMARIZE

Mainly propose

Grease pump are designed to be used in pumping greases only. Any other use can cause unsafe operating conditions and result in component rupture, fire or explosion, which can cause serious injury, including fluid injection.

SAFETY INSTRUCTIONS



WARNING: No complying with below requests will result in severely harm to your body even death.

EQUIPMENT MISUSE HAZARD: Equipment misuse can cause the equipment to rupture or malfunction and result in serious injury.

- This equipment is for professional use only.
- Read all instruction manuals, tags, and labels before you operate this equipment. Use the equipment only for its intended purpose. If you are not sure, call us or your local agent.
- Do not modify this equipment. If you need to replace the parts, use the standard parts or components.
- Check equipment daily. Repair or replace worn or damaged parts immediately.
- Do not exceed the maximum working pressure of the lowest rated component in your system.
- Use fluids and solvents which are compatible with the equipment wetted parts. Read the fluid and solvent manufacturer's warnings.
- Forbidding on other chemical or may cause damage to the pumps body.
- Handle hoses carefully. Do not pull on hoses to move equipment.
- Route hoses away from traffic areas, sharp edges, moving parts, and hot surfaces.
- Do not use low pressure hoses in the system.. Before operating the control valve, put the hoses straight. Using of the hoses should comply with certain conditions.
- Put on heat insulation gloves when operating the pumps.
- Do not move or lift pressurized equipment.
- Comply with all applicable local, state, and national fire, electrical, and safety regulations.

SKIN INJECTION HAZARD

Fluid from the dispensing valve, leaks, or ruptured components can inject fluid into your body and cause extremely serious injury. Fluid splashed in the eyes or on the skin can also cause serious injury.

- Do not point the dispensing valve at anyone or at any part of the body.
- Do not stop or deflect leaks with your hand, body, glove or rag.
- Do not use the grease which have been polluted.
- Use only extensions and no-drip tips which are designed for use with your dispensing valve. Follow the Pressure Relief Procedure if the grease fitting coupler clogs and before you clean or service this equipment.

- Check the hoses, tubes, and couplings daily. Replace worn or damaged parts immediately. Do not repair high pressure couplings; you must replace the entire hose.

MOVING PARTS HAZARD

Moving parts, such as the air motor piston, can pinch or amputate your fingers.

- Keep clear of all moving parts when you start or operate the pump.
- Before you service this equipment, follow the Pressure Relief Procedure to prevent the equipment from starting unexpectedly.
- Before operating the pumps, moving parts should not to be exposed outside.

FIRE AND EXPLOSION HAZARD

Improper grounding, poor ventilation, open flames or sparks can cause a hazardous condition and result in a fire or explosion and serious injury.

- Ground the equipment and the object being dispensed to.
- Effective lubricate to the moving parts.
- If there is any static sparking or you feel an electric shock while using this equipment, stop dispensing immediately. Do not use the equipment until you identify and correct or the fluid being dispensed.
- Provide fresh air ventilation to avoid the buildup of flammable fumes from solvents or the fluid being dispensed.
- Keep the dispensing area free of debris, including solvent, rags, and gasoline.
- Do not smoke in the dispensing area.

INSTALLATION

Grounding

⚠ WARNING: Before operating the pump, check the grounding of whole system. And avoid occurring of fire and explosion.

To reduce the risk of static sparking, effectively ground all of this equipment.

- Pump: Refer to fig.2. Use a ground wire and clamp as shown in Fig. 2. Remove the ground screw 1, onto the pump and tighten securely. Connect the other end of the ground wire to a true earth ground. Insert through the eye of the ring terminal at end of the ground wire 2. Fasten the ground screw back.
- Air and fluid hoses: Effectively grounding.
- Air compressor: Follow the manufacturer's recommendations.
- Control valve: Use proper grounding line to connect the pump. Keep the metal part of the control valve connect with the grounding equipment.
- Barrel: Use the barrel which is under the permission of local area. If it is a metal barrel, put it on the ground which is with electric capability. If no grounding paper or board, it is not allowed to put on the surface of non-conductor directly.
- Other components: Comply with local grounding requests.
- Keep effective grounding when working or pressure releasing.

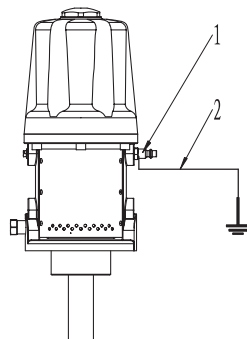

Fig.2: Grounding guide

Typical installation

Typical installation refers to Fig.3:

1. Bleed-type master air valves
2. Air line filter
3. Air regulator with gauge
4. Air line lubricator
5. Pump runaway valve
6. Drum cover
7. Follower plate
8. Hose reel

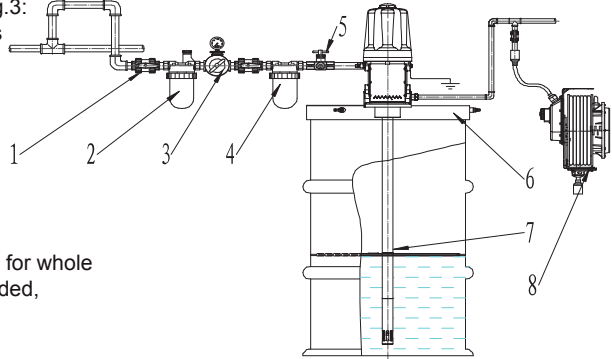

Fig.3: Oil supply system installation

Above typical installation is not for whole system design. If any help needed, please contact us.

Installation of air line

NOTE: Do not hang any equipment to the air inlet as it may cause falling down by poor hanging equipment.

Process

- Install a pump on drum cover (See fig.3 part 6), and then to barrel.
- On the main line of air compressor, connect bleed-type master air valves which controls on and off air motor (See fig.3 part 1).
- Install an air line filter (See fig.3 part 2). Remove harmful dirt and contaminants from your compressed air supply.
- Install the air regulator to control pump speed and pressure (See fig.3 part 3).
- Install an air line regulator for automatic air motor lubrication (See fig.3 part 4).
- Install a pump run-away valve to shut off the air to the pump if the pump accelerates beyond the pre-adjusted setting. A pump that runs too fast can be seriously damaged (See fig.3 part 5).
- Connect outlet line.

OPERATION

Pressure relieve

Skin injection hazard: The equipment stays pressurized until pressure is manually relieved. To reduce the risk of serious injury from pressurized fluid, fluid from the valve or splashing fluid, follow this procedure whenever you.

- Are instructed to relieve pressure.
- Stop dispensing.
- Check, clean or service any system equipment.
- Install or clean dispensing devices.

Pressure relief procedure

- Close the pump air regulator and the bleed-type master air valve.
- Hold a metal part of the dispensing valve firmly to a grounded metal waste container and trigger the valve to relieve the fluid pressure.
- Open the air line valve and grease line valve.
- Close the control valve.

When occurs :

- Problems on control valve, flexible hose, rigid tube or manual tip, auto tip.
- Pressure not relieve thoroughly according to above relief procedure.
- Pressure relieved very slowly until relieved thoroughly. Please clear obstruction of grease system.

Procedure

NOTE: When the pump is primed, and with sufficient air supplied, the pump starts when the dispensing valve is opened and shuts off when it is closed.



WARNING: The maximum working pressure of each component in the system may not be the same. To reduce the risk of over pressurizing any component in the system, be sure you know the maximum working pressure of each component. Never exceed the maximum working pressure of the lowest rated component in the system. Over pressurizing any component can result in rupture, fire, explosion, property damage, and serious injury. The maximum pressure in the system is equal to air input pressure times pump ratio. Regulate air to the pump so that air line or fluid line component or accessory is over pressurized.



CAUTION: Never allow the pump to run dry of the material being pumped. A dry pump will quickly accelerate to a high speed, possibly damaging itself. If your pump accelerates quickly, or is running too fast, stop it immediately and check the material supply. If the supply container is empty and air has been pumped into the lines, prime the pump and lines with material, or flush it and leave it filled with a compatible solvent. Be sure to eliminate all air from the material lines.

Startup

- If there are multiple pumps on the air line, close the air regulators and bleed-type master air valves to all but one pump.
- Open the master air valve from the compressor.
- Open the dispensing valve into a grounded metal waste container, making firm metal-to-metal contact between the container and valve. Open the bleed-type master air valve and open the pump air regulator slowly, just until the pump is running. When the pump is primed and all air has been pushed out of the lines, close the dispense valve.
- If you have more than one pump, repeat this procedure for each pump.
- Set the air pressure to each pump at the lowest pressure needed to get the desired results.
- Never allow the pump to run dry of the material being pumped.
- Relieve pressure before you check or service any system equipment.

TROUBLE SHOOTING



WARNING:

- To reduce the risk of serious injury whenever you are instructed to relieve pressure.
- MOVING PARTS HAZARD** Never operate the pump with the warning plate or the identification plate removed. These plates protect your fingers from pinching or amputation by moving parts in the air motor.

Relieve pressure before you check or service any system equipment.

Problem	Cause	Solution
Pumps fails to operate	Inadequate air supply pressure or restricted air lines	Increase air supply and/or clear restriction.
	Closed or clogged pump valves	Open and/or clean.
	Clogged fluid line, hose, valve, or other accessory	Relieve pressure. Clear obstruction.
	Damaged air motor	Assess damage, and service air motor.
	Exhausted fluid supply	Refill and reprime or flush.
Continuous air exhaust	Worn or damaged air motor gasket or seal	Assess wear or damage, and service air motor.
Erratic pump operation	Exhausted fluid supply	Refill and reprime or flush.
	Worn pump seals	Replace.
	Damaged shovel tube	Replace.
	Worn piston seal	Replace.
Pump operates, but output low	Worn seals	Replace.
	Clogged fluid line, hose, valve, or other accessory	Relieve pressure. Clear obstruction.
	Worn throat seal	Replace.
Grease leaking from muffler plates	Worn throat seal	Replace.

LIMITED WARRANTY

- Macnaught warrants this product against defects in material and craftsmanship, for a period of 3 years from date of purchase, but not including wearing parts.
- Macnaught's liability is limited to replacement or repair of defective material within the warranty period, when returned freight prepaid to the distributor or their designated service depot.
- The warranty does not cover damage caused by accident, misuse or faulty installation.
- The product must be installed and maintained in compliance with the instructions.

EXPLODED AND PARTS LIST

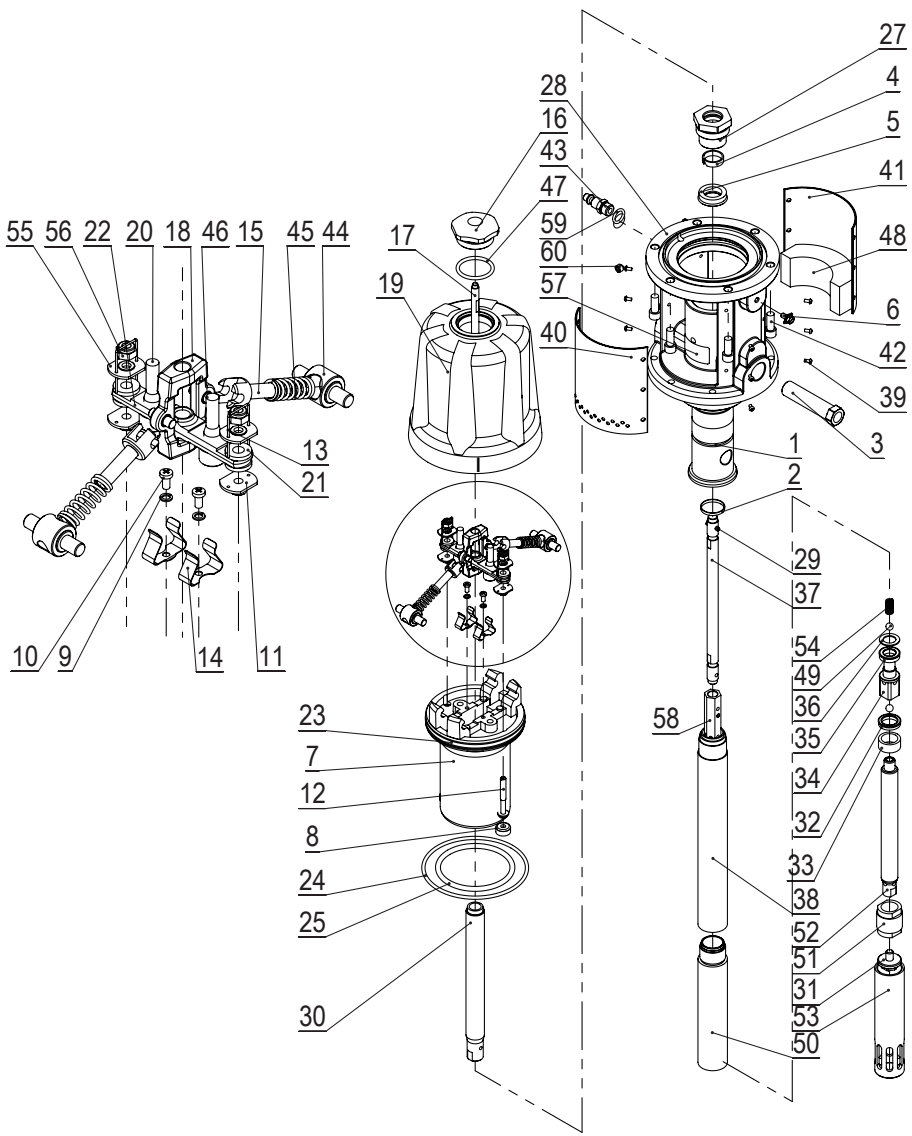

Part No.	Description	QTY	Part No.	Description	QTY
1	Tube	1	32#	U Seal	1
2#	Gasket	2	33	Copper ring	1
3	Oil outlet	1	34	Connector	1
4	Guiding	1	35#	Seal	1
5#	Seal	1	36	Gasket	1
6	Bolt	1	37	Rod	1
7	Piston	1	38	Tube	1
8#	Seal	2	39	Screw	12
9	Washer	2	40	Right silencer	1
10	Screw	2	41	Left silencer	1
11	Nut	2	42	Screw	6
12	Rod	2	43	Quick plug	1
13	Steel-wire	2	44	Rocker	2
14#	Spring piece	2	45#	Spring	2
15	Rope shaft	2	46	Pin	2
16	Air motor cover	1	47#	O-ring	1
17	Rod	1	48#	Sponge	2
18	Yoke	1	49	Ball	2
19	Jar body	1	50	Tube	1
20#	Gasket	2	51	Adapter	1
21#	Cushion	2	52	Shaft	1
22	Shaft	1	53	Oil inlet	1
23#	O-ring	1	54	Spring	1
24#	O-ring	1	55	Adjustable nut	2
25#	O-ring	1	56#	Nut	2
27	Nut	1	57	Label	2
28	Base	1	58	Rod	1
29#	Pin	2	59#	O-ring	1
30	Rod	1	60	Screw	2
31	Shovel washer	1			

Note: The Part No. with “#” are the wearing parts.



Macnaught Americas
(813) 628-5506 | info@macnaughtusa.com

* Read Manual Before Use!