



DC/AC Fuel Transfer Pumps Instruction Manual



WARNING:

Read carefully and understand all **INSTRUCTIONS** before operating. Failure to follow the safety rules and other basic safety precautions may result in serious personal injury. Save these instructions in a safe place and on hand so that they can be read when required. Keep these instructions to assist in future servicing.



GENERAL SAFETY REGULATIONS



WARNING: The warnings, cautions, and instructions discussed in this instruction manual cannot cover all possible conditions or situations that could occur. It must be understood by the operator that common sense and caution are factors that cannot be built into this product, but must be supplied by the operator.

1. Keep the work area clean and dry. Damp or wet work areas can result in injury.
2. Keep children away from work area. Do not allow children to handle this product.
3. Use the right tool for the job. Do not attempt to force small equipment to do the work of larger industrial equipment. There are certain applications for which this equipment was designed. It will do the job better and more safely at the capacity for which it was intended. Do not modify this equipment, and do not use this equipment for a purpose for which it was not intended.
4. Check for damaged parts. Before using this product, carefully check that it will operate properly and perform its intended function. Check for damaged parts and any other conditions that may affect the operation of this product. Replace damaged or worn parts immediately.
5. Do not overreach. Keep proper footing and balance at all times to prevent tripping, falling, back injury, etc.
6. DO NOT use the equipment when tired or under the influence of drugs, alcohol, or medication. A moment of inattention while operating this equipment may result in serious personal injury.

TECHNICAL DETAILS

Item No.	Electrical Power		Flow Rate	Nozzles	Pump Model
	Current	Voltage	GPM/LPM		
FTP12-001	DC	12V	Up to 15/57	Auto	17530572
EXDFP12-001	DC	12V	Up to 20/76	Auto	17530764
EXDFP120-001	AC	120V	Up to 15/57	Auto	17330573
FTP120-001	AC	120V	Up to 20/76	Auto	17330762

* Use an automatic nozzle and/or filter will reduce flow rate.

These products are positive displacement, rotary vane pumps. Depending on installation and viscosity, these pumps can deliver up to 20GPM or 76 LPM. Their rugged design makes for a long life of dependability.

- Inlet: 2" male on tank adapter, 1" female on pump
- Outlet: 1" female
- Built-in bypass valve
- Filter screen
- Thermal overload protection
- Furnished with:
 - * 14ft/4.2m, 3/4" hose for 15GPM/57LPM
 - * 14ft/4.2m, 1" hose for 20GPM/76LPM
 - * 1pc steel suction pipe
 - * 1pc manual or Auto nozzle
- Class I Division 1 Group D T4

SAFETY PRECAUTIONS

To ensure safe and efficient operation, it is essential to read and follow each of these warnings and precautions.

1. DO NOT smoke near pump or use pump near an open flame. Fire could result.
2. Disconnect power to pump before servicing pump.
3. Turn off the switch before connecting power.
4. Take motors needing service to an authorized repair shop or return to factory to maintain.
5. A filter should be used on pump outlet to ensure that no foreign material is transferred to fuel tank.
6. Tank or barrel should be anchored to prevent tipping in both the full and empty conditions.
7. The pump motor is equipped with thermal overload protection. If overheated, it will shut itself off without any damage to the windings. Move ON/OFF lever to the "OFF" position to reset pump.



WARNING

1. Electrical wiring should be done a licensed electrician in compliance with local codes. Rigid conduit should be used and proper ground must be provided to avoid the possibility of electrical shock. Failure to comply with this warning could result in serious injury and/or loss of property. Use only Static wire, conductive hose when pumping flammable fluids.
2. This product should not be used for fluid transfer into aircraft. This product is not suited for use with fluids for human consumption or fluids containing water.
3. Extreme operating conditions with working cycles longer than 30 minutes can cause the motor temperature to rise, thus damaging the motor itself. Each 30-minute working cycle should always be followed by a 30-minute power-off cooling phase.
4. Use PTFE tape on all pipe threads.
5. **MAXIMUM BY-PASSING TIME: 3 MINUTES.**
6. **DO NOT RUN WITHOUT FLUID.**
7. Hot surface-to reduce the risk of burns, do not touch.
8. Disconnect circuit before removing cover and enclosure must be closed tightly when circuits are alive.
9. A seal shall be installed within 50mm of the enclosure.

OPERATION

OPERATING CONDITIONS

- Temperature: min -20°C/max +40°C (-4°F /max 104°F)
- Relative Humidity: max 90%

FLUID COMPATIBILITY

- These products are compatible with the following fluids: Gasoline, Diesel, Kerosene & Mineral Spirits
- **Do NOT use with other fluids without consulting manufacturer.**

INSTALLATION

1. Tightly screw suction pipe into inlet coupling of pumping unit. Extend suction pipe into truck tank or barrel to within 3" of tank bottom.
2. Screw inlet coupling of pump into 2" tank or barrel opening. Inlet coupling must be completely and securely threaded into an undamaged tank or barrel bung.
3. During installation and maintenance, make sure that the electric supply lines are not live.
4. Always turn off the switch before supplying electrical power.
5. Check the correct rotation direction of the DC pump. If it is inverted, check the polarity of the connection cable.
 - a) RED cable: positive pole (+)
 - b) BLACK cable: negative pole (-)
6. Systems should be designed to require a minimum amount of suction lift. Maximum "equivalent feet of lift" is 8' for diesel fuel.
7. Tank or barrel must be properly vented. A water separator should be used for pumping diesel fuel.
8. DC Electrical:
 - 8.1 Remove pump's junction box cover and straighten the 2 wires to make the stripped wire ends accessible outside of the junction box.
 - 8.2 Screw furnished cable connector into 1/2" NPT conduit opening in pump junction box.
 - 8.3 Strip 6in. of the outer covering from one end of the furnished electrical cable being careful not to damage the black and red wire insulation.
 - 8.4 Loosen cable connector nut and pass the stripped end of the furnished cable through the cable connector until 2in. of the unstrapped cable is within the cable connector. Tighten the cable connector nut.
 - 8.5 Strip 1/2" of the installation from the ends of the red and black cable wires. Using the furnished wire nuts, connect these wires to the pump wires matching the colors. Be sure no bare wire is exposed.
 - 8.6 Fold wires into junction box and replace cover making sure the gasket is in place. Make sure all screws are seated so there is no space between the cover and the junction box.
9. AC Electrical
 - 9.1 Electrical wiring should be done by a licensed electrician in compliance with local, state and national codes.
 - 9.2 Remove the pump's electrical junction box cover and straighten the 3 wires to make the stripped wire ends accessible outside of the junction box.
 - 9.3 Install rigid conduit and wires from the power source to the junction box to maintain explosion-proof integrity.
 - 9.4 Connect wires to pump connecting like colored wires together. Ground wire must be connected.
 - 9.5 Fold wires into junction box and replace cover making sure the gasket is in place. Make sure all screws are seated so there is no space between the cover and the junction box. The installation is now complete.

PROBLEMS AND SOLUTIONS

Problem	Possible Cause	Corrective Action	
The motor is not turning	Lack of electric power	Check the electrical connections and the safety systems	
	Rotor jams	Check for possible damage or obstruction of the rotating components.	
	Motor problems	Contact with the service department	
	Thermal overload protection shut	Move ON/OFF lever to the "OFF" position to reset pump.	
Low or no flow rate	Low level in the suction tank	Refill the tank	
	Foot valve blocked	Clean and/or replace the valve	
	Filter clogged	Clean the filter	
	Excessive suction pressure	Lower the pump with respect to the Level	
	High loss of head in the circuit (working with the by-pass open)	Use shorter tubing or of greater Diameter	
	By-pass valve blocked	Dismantle the valve, clean and/or replace it	
	Air entering the pump or the suction tubing	Check the seals of the connections	
	A narrowing in the suction Tubing	Use tubing suitable for working under suction pressure	
	Low rotation speed		Check the voltage at the pump.
			Adjust the voltage and/or use cables of greater cross-section
	The suction tubing is resting on the bottom of the tank	Raise the tubing	
Increased pump noise	Cavitations occurring	Reduce suction pressure	
	Irregular functioning of the by-pass	Dispense until the air is purged from the circuit	
Leakage from the pump body	Air present in the diesel fuel	Verify the suction connections	
	Seal damaged	Check and replace the mechanical seal	

DAILY USE

- If using flexible tubing, attach the ends of the tubing to the tanks. In the absence of an appropriate slot, solidly grasp the delivery tube before beginning dispensing.
- Before starting the pump make sure that the delivery valve is closed (dispensing nozzle or line valve).
- Turn the ON/OFF switch to ON. The by-pass valve allows functioning with the delivery closed for only brief periods.
- Open the delivery valve, solidly grasping the end of the tubing.
- Close the delivery valve to stop dispensing.
- When dispensing is finished, turn off the pump.

MAINTENANCE

Under normal working conditions the noise emission from all models does not exceed the value of 80 db at a distance of 1 meter from the electric pump.

LIMITED WARRANTY

1. Macnaught warrants this product against defects in material and craftsmanship, for a period of two years from date of purchase, but not including wearing parts.
2. Macnaught's liability is limited to replacement or repair of defective material within the warranty period, when returned freight prepaid to the distributor or their designated service depot.
3. The warranty does not cover damage caused by accident, misuse or faulty installation.
4. The product must be installed and maintained in compliance with the instructions.

EXPLODED AND PARTS LIST

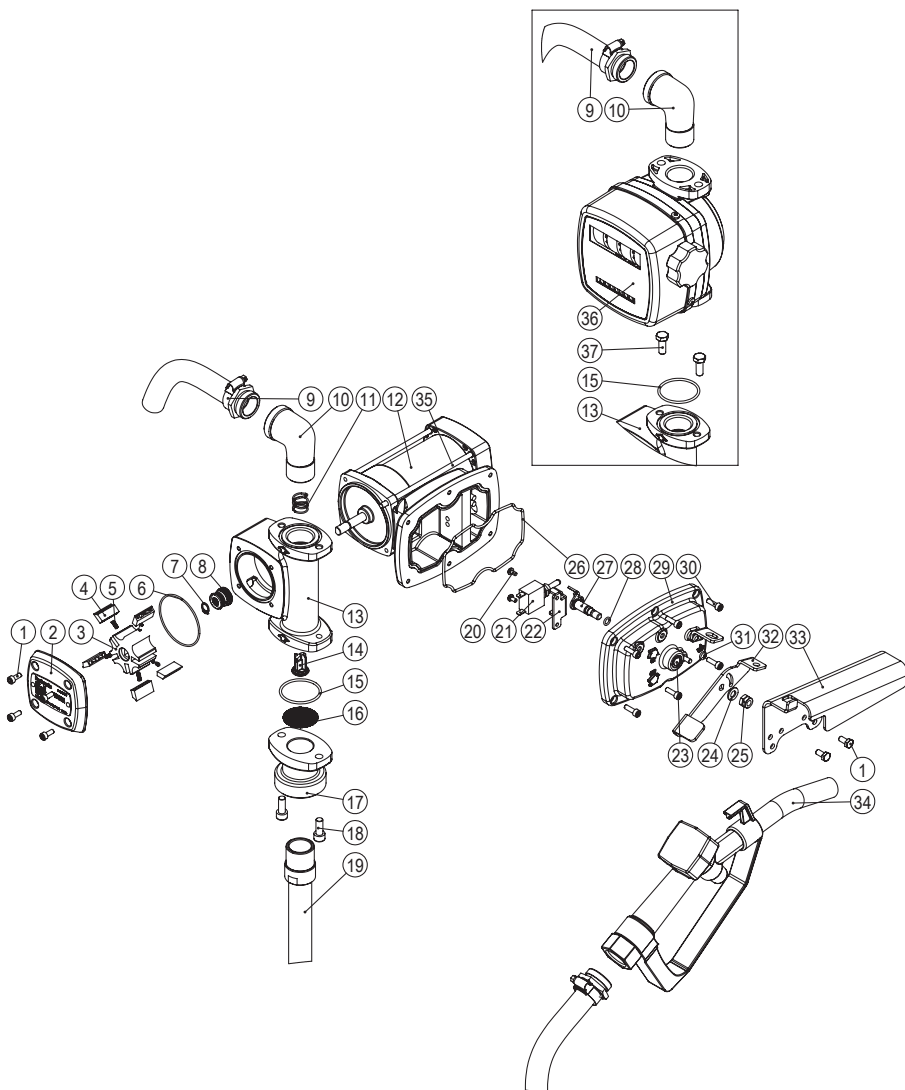

Part No.	Description	Q'ty	Part No.	Description	Q'ty
1	Screw	6	20	Screw	2
2	Rotor cover	1	21	Switch	1
3	Rotor	1	22	Bracket	1
4*	Vane	5	23	Bushing	1
5*	Spring	5	24	Gasket	1
6*	O-ring	1	25	Nut	1
7	Gasket	1	26	Seal	1
8	Seal Kit	1	27	Shift folk	1
9*	Discharge hose	1	28	O-ring	1
10	Elbow	1	29	Junction box cover	1
11	Bypass spring	1	30	Screw	6
12	Electric motor	1	31	Grounded screw	1
13	Pump chamber	1	32	Switch bracket	1
14	Bypass valve	1	33	Nozzle holder	1
15*	O-ring	1	34	Nozzle	1
16	Filter screen	1	35	Screw	2
17	2" Bung adapter	1	36	Mechanical meter (Optional)	1
18	Screw	2	37	Screw	2
19	Suction tube	1			

* Wearing parts.



Macnaught Americas
(813) 628-5506 | info@macnaughtusa.com

*** Read Manual Before Use!**