



# DC 12V Fuel Transfer Pump Instruction Manual

---



FP12-001



---

## **WARNING:**

Read carefully and understand all **INSTRUCTIONS** before operating. Failure to follow the safety rules and other basic safety precautions may result in serious personal injury. Save these instructions in a safe place and on hand so that they can be read when required. Keep these instructions to assist in future servicing.

---



## GENERAL SAFETY REGULATIONS



**WARNING:** The warnings, cautions, and instructions discussed in this instruction manual cannot cover all possible conditions or situations that could occur. It must be understood by the operator that common sense and caution are factors that cannot be built into this product, but must be supplied by the operator.

1. Keep the work area clean and dry. Damp or wet work areas can result in injury.
2. Keep children away from work area. Do not allow children to handle this product.
3. Use the right tool for the job. Do not attempt to force small equipment to do the work of larger industrial equipment. There are certain applications for which this equipment was designed. It will do the job better and more safely at the capacity for which it was intended. Do not modify this equipment, and do not use this equipment for a purpose for which it was not intended.
4. Check for damaged parts. Before using this product, carefully check that it will operate properly and perform its intended function. Check for damaged parts and any other conditions that may affect the operation of this product. Replace damaged or worn parts immediately.
5. Do not overreach. Keep proper footing and balance at all times to prevent tripping, falling, back injury, etc.
6. DO NOT use the equipment when tired or under the influence of drugs, alcohol, or medication. A moment of inattention while operating this equipment may result in serious personal injury.

## DECLARATION OF CONFORMITY

IN CONFORMANCE WITH THE DIRECTIVES

98/37/EEC (MACHINERY • 97/23/EEC (PRESSURE VESSELS)

89/336/EEC (ELECTRO-MAGNETIC COMPATIBILITY) AND FURTHER  
MODIFICATIONS

2000/14 DIRECTIVE ON LIMITATION OF NOISE

**Macnaught Americas**

**(813) 628-5506 | [info@macnaughtusa.com](mailto:info@macnaughtusa.com)**

DECLARES THAT THE FOLLOWING PUMP MODELS:

FP12-001

To which this declaration refers, conform to the following applicable regulations:

EUROPEAN REGULATIONS:

EN292-1-92 – Safety of Machinery – General Concepts, basic principles for design – terminology, basic methodology

EN292-2-92 – Safety of Machinery – General Concepts, basic principles for design – specifications and technical principles

EN294-93 – Safety of Machinery – safe distances to prevent the operator's upper limbs from reaching dangerous areas

EN60034-1-2000 – Rotating electrical Machinery – nominal and functional specifications

EN60034-5-2001 – Classification of grades of protection for the housings of rotating electrical machinery

EN61000-6-3 – Electro – magnetic compatibility – generic emission standards

EN61000-6-1 – Electro – magnetic compatibility – generic immunity standards

EN55014-1-00(A1/99-A2/99) limits and methods for measuring radio disturbance characteristics

EN55014-2-97 – Electrical motor – operated and thermal appliances for household and similar purposes, electric tools and similar electrical apparatus

EN60204-1-98 – safety of machinery – electrical equipment of machines

## TECHNICAL DETAILS

Item No.	Electrical Power		Flow Rate	Fuses
	Current	Voltage	GPM/LPM	
FP12-001	DC	12V	10/40	25

**PUMP:** Self-priming, volumetric, rotating vane pump, equipped with by-pass valve.

**MOTOR:** Brush motor, DC, low tension with intermittent cycle, closed type in protection class IP55, directly flanged to the pump body.

## OPERATING

## ENVIRONMENTAL CONDITIONS

1. Temperature: Min. -20°C, Max. +60°C
2. Relative Humidity: Max. 90%

**ATTENTION!**

The temperature limits shown apply to the pump components and must be respected to avoid possible damage or malfunction.

## ELECTRICAL POWER SUPPLY

1. Depending on the model, the pump must be supplied by a single-phase alternating current line whose nominal values are shown in the table in Paragraph C1 – ELECTRICAL DATA.
2. The maximum acceptable variations from the electrical parameters are: Voltage +/-5% of the nominal value.
3. Power from lines with values outside the indicated limits can damage the electrical components.

**ATTENTION!**

Power from lines with values outside the indicated limits can damage the electrical components.

## WORKING CYCLE

**ATTENTION!**

1. Extreme operating conditions with working cycles longer than 30 minutes can cause the motor temperature to rise, thus damaging the motor itself.
2. Each 30-minute working cycle should always be followed by a 30-minute power-off cooling phase.
3. MAXIMUM BY-PASSING TIME: 3 MINUTES.
4. DO NOT RUN DRY OVER 30 SECONDS.

**ATTENTION!**

Functioning under by-pass conditions is only allowed for brief periods of time (2-3minutes maximum).

**FLUIDS PERMITTED / FLUIDS NOT PERMITTED  
PERMITTED**

1. DIESEL FUEL at a VISCOSITY from 2 to 5.35 cSt (at a temperature of 37.8°C)
2. Minimum Flash point (PM): 55°C

**NOT PERMITTED**

Description	Related Dangers
Gasoline	Fire – Explosion
Inflammable Liquids With Pm<55°C	Fire – Explosion
Liquids With Viscosity>20cst	Motor Overload
Water	Pump Oxidation
Food Liquids	Contamination Of The Same
Corrosive Chemical Products	Pump Corrosion, Injury To Persons
Solvents	Fire – Explosion, Damage To Gasket Seals

**MOVING AND TRANSPORT**

Given the limited weight and size of the pumps (see overall dimensions), moving the pumps does not require the use of lifting devices.

The pumps were carefully packed before shipment. Check the packing material on delivery and store in the dry place.

**INSTALLATION****DISPOSING OF THE PACKING MATERIAL**

1. The packing material does not require special precautions, not being in any way dangerous or polluting.
2. Refer to local regulations for its disposal.

**PRELIMINARY INSPECTION**

1. Check that the machine has not suffered any damage during transport or storage.
2. Clean the inlet and outlet openings, removing any dust or residual packing material.
3. Check that the electrical specifications correspond to those shown on the identification plate.

**POSITIONING THE PUMP**

1. The pump can be installed in any position (pump axis vertical or horizontal).
2. Attach the pump using screws of adequate diameter for the attachment holes provided in the base of the pump (see the section “OVERALL DIMENSIONS” for their position and dimension).

**ATTENTION!**

**THE MOTORS ARE NOT OF AN ANTI-EXPLOSIVE TYPE.**

**Do not install them where inflammable vapours can be present.**

**CONNECTING THE TUBING**

1. Before connection, make sure that the tubing and the suction tank are free of dirt and thread residue that could damage the pump and its accessories.
2. Before connecting the delivery tube, partially fill the pump body with diesel fuel to facilitate priming.
3. Do not use conical threaded joints that could damage the threaded pump openings if excessively tightened.
4. The pump is not provided with any filter. Always install suction filter (on all of the models it is included).

**SUCTION TUBING**

1. Minimum recommended nominal diameter: 3/4”
2. Nominal recommended pressure: 10bar/145PSI
3. Use tubing suitable for functioning under suction pressure.

## DELIVERY TUBING

1. Minimum recommended nominal diameter: 3/4"
2. Nominal recommended pressure: 10bar/145PSI



### ATTENTION!

1. It is the installer's responsibility to use tubing with adequate characteristics.
2. The use of tubing unsuitable for use with diesel fuel can damage pump, injure persons and cause pollution.
3. Loosening of the connections (threaded connections, flanging, gasket seals) can cause serious ecological and safety problem.
4. Check all the connections after the initial installation and on a daily basis after that.
5. Tighten the connections, if necessary.

## CONSIDERATIONS REGARDING DELIVERY AND SUCTION LINES

### DELIVERY

The choice of pump mode must be made keeping the characteristics of the system in mind. The combination of the length of the tubing, the diameter of the tubing, the flow rate of the diesel fuel and the line accessories installed can create back pressure greater than the maximums anticipated such as to cause the (partial) opening of the pump by-pass with the consequent noticeable reduction of the flow rate supplied.

In such cases, to allow correct functioning of the pump, it is necessary to reduce system resistance, using shorter tubing and/or of wider diameter and line accessories with less resistance (e.g. an automatic dispensing nozzle for greater flow rates).

### SUCTION

All models are equipped with a self-priming pump with a good suction capacity.

During the start-up phase, with an empty suction tube and the pump wetted with fluid, the electric pump unit is capable of suctioning the liquid with a maximum difference in height of 2 meters. It is important to point out that the priming time can be as long as one minute and the pressure of an automatic dispensing nozzle on the delivery line prevents the evacuation of air from the installation, and, therefore, prevents proper priming.

For this reason, it is always advisable to prime the pump without an automatic delivery nozzle, verifying the proper wetting of the pump. The installation of a foot valve is recommended to prevent the emptying of the suction tube and to keep the pump wet. In this way, the pump will subsequently always start up immediately.

When the system is functioning, the pump can work with pressure at the inlet as high as 0.5bar/7PSI, beyond which cavitation phenomena can begin, with a consequent loss of flow rate and increase of system noise.

As we have said up to this point, it is important to guarantee low suction pressure by using short tubing of a diameter equal to or larger than recommended, reducing curves to a minimum and using suction filter of wide cross-section and foot valves with the lowest possible resistance.

The difference in height between the pump and the fluid level must be kept as small as possible and, at any rate, within the 2 meters anticipated for the priming phase.

If this height is exceeded, it will always be necessary to install a foot valve to allow for the filling of the suction tube and provide tubing of wider diameter. It is recommended that the pump not be installed at a difference in height greater than 3 meters.

**ATTENTION!**

In the case that the suction tank is higher than the pump, it is advisable to install an anti-siphon valve to prevent accidental diesel fuel leaks.

Dimension the installation in order to control the back pressure due to water hammering.

**CONFIGURATIONS**

Electric pump with terminal strip box complete of switch (on 12V and 24V versions), with safety fuse and pincers for connection to the battery, handle for easier moving.

**ELECTRICAL CONNECTIONS****1. Terminal strip box complete of:**

- ON/OFF switch;
- Safety fuse against short circuits and overcurrent, featuring the following characteristics:  
25A for 12V models  
15A for 24V models

**2. 2m/6.6ft power cable complete of pincers for connection to the battery**

- RED cable: positive pole (+)
- BLACK cable: negative pole (-)

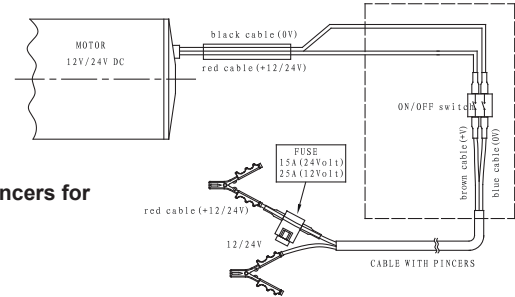
**ATTENTION!**

IT IS THE INSTALLER'S RESPONSIBILITY TO PREFORM THE ELECTRICAL CONNECTIONS WITH RESPECT FOR THE APPLICABLE REGULATIONS.

Respect the following (not exhaustive) instructions to ensure a proper electrical installation:

1. During installation and maintenance, make sure that the electric supply lines are not live.
2. Use cables characterized by the minimum cross-sections, nominal voltages and wiring-type adequate to the electrical characteristics shown in paragraph E2 – ELECTRICAL SPECIFICATIONS and the installation environment.
3. ALWAYS close the cover of the strip box before supplying electrical power.
4. Check the correct rotation direction of the pump. If it is inverted, check the polarity of the connection cable.

**INITIAL START-UP**

1. Check that the quantity of diesel fuel in the suction tank is greater than the amount you wish to transfer.
2. Make sure that the residual capacity of the delivery tank is greater than the quantity you wish to transfer.
3. Do not run the pump without liquid. This can cause serious damage to its components.
4. Make sure that the tubing and line accessories are in good condition.
5. Diesel fuel leak can damage objects and injure person.
6. Never start or stop the pump by connecting or cutting out the power supply.
7. Do not operate switches with wet hands.
8. Prolonged contact with diesel fuel can damage the skin. The use of glasses and gloves is recommended.

**ATTENTION!**

Extreme operating conditions with working cycles longer than 30 minutes can cause the motor temperature to rise, thus damage the motor itself.

Each 30-minute working cycle should always be followed by a 30-minute power-off cooling phase.

In the priming phase the pump must blow the air initially present in the entire installation out of the delivery line. Therefore it is necessary to keep the outlet open to permit the evacuation of the air.



### **ATTENTION!**

**If an automatic type dispensing nozzle is installed at the end of the delivery line, the evacuation of the air will be difficult because of the automatic stopping device that keeps the valve closed when the line pressure is too low. It is recommended that the automatic dispensing nozzle be temporarily disconnected during the initial start-up phase.**

The priming phase can last from several second to a few minutes, as a function of the characteristics of the system. If this phase is prolonged, stop the pump and verify:

1. That the pump is not running completely without liquid.
2. That the suction tubing is not allowing air to seep in.
3. That the suction filter is not clogged.
4. That the suction height does not exceed 2m. (if the height exceeds 2m, fill the suction hose with fluid).
5. That the delivery tube is allowing the evacuation of the air.

When priming has occurred, verify that the pump is operating within the anticipated range, in particular:

1. That under conditions of maximum back pressure, the power absorption of the motor stays within the values shown on the identification plate.
2. That the suction pressure is not greater than 0.5bar.
3. That the back pressure in the delivery line is not greater than the maximum back pressure foreseen for the pump.

### **DAILY USE**

1. If using flexible tubing, attach the ends of the tubing to the tanks. In the absence of an appropriate slot, solidly grasp the delivery tube before beginning dispensing.
2. Before starting the pump, make sure that the delivery valve is closed (dispensing nozzle or line valve).
3. Turn the ON/OFF switch on. The by-pass valve allows functioning with delivery closed only for brief periods.
4. Open the delivery valve, solidly grasping the end of the tubing.
5. Close the delivery valve to stop dispensing.
6. When dispensing is finished, turn off the pump.



### **ATTENTION!**

Functioning with the delivery closed is only allowed for brief periods (2 / 3 minutes maximum). After use, make sure the pump is turned off.

### **NOISE LEVEL**

Under normal working conditions the noise emission from all models does not exceed the value of 70 db at a distance of 1 meter from the electric pump.

### **DISPOSING OF CONTAMINATED MATERIALS**

In the event of maintenance or demolition of the machine, do not disperse contaminated parts into the environment. **Refer to local regulations for their proper disposal.**



## TROUBLE SHOOTING GUIDE

Problem	Possible Cause	Corrective Action
The Motor is not turning	Lack of electric power	Check the electrical connecting
	Rotor Jammed	Check for possible damage or obstruction of the rotating components
	Motor Problems	Contact the Service Department
The motor turns slowly when starting	Low voltage in the electric power line	Bring the voltage back within the anticipated limits
Low or no flow rate	Low level in the suction tank	Refill the tank
	Foot valve blocked	Clean and/or replace the valve
	Filter clogged	Clean the filter
	Excessive suction pressure	Lower the pump with respect to the level of the tank or increase the cross-section of the tubing
	High loss of head in the delivery circuit (working with the by-pass open)	Use shorter tubing or of greater diameter
	By-pass valve blocked	Dismantle the valve, clean and/or replace it.
	Air entering the pump or the suction tubing	Check the seals of the Connections
	A narrowing in the suction tubing	Use tubing suitable for working under suction pressure
	Low rotation speed	Check the voltage at the pump. Adjust the voltage and/or use cables of greater cross-section
	The suction tubing is resting on the bottom of the tank	Raise the tubing
Increased pump noise	Cavitation occurring	Reduce suction pressure
	Irregular functioning of the by-pass	Dispense fuel until the air is purged from the by-pass system
	Air present in the diesel fuel	Verify the suction connection
Leakage from the pump body	Seal Damaged	Check and replace the seal

## MAINTENANCE

All models are designed and constructed to require a minimum of maintenance.

In any case always bear in mind the following basic recommendations for a good functioning of the pump:

- On a weekly basis, check that the tubing joints have not loosened, to avoid any leakage.
- On a monthly basis, check the pump body and keep it clean of any impurities.
- On a weekly basis, check and keep clean the line suction filter.
- On a monthly basis, check that the electric power supply cables are in good condition.
- Check on a monthly basis and keep clean the dispensing nozzle provided with all the models. Anyway keep clean any other final check valve installed.
- Check on a monthly basis and keep the suction filters clean.

## LIMITED WARRANTY

1. Macnaught warrants this product against defects in material and craftsmanship, for a period of two years from date of purchase, but not including wearing parts.
2. Macnaught's liability is limited to replacement or repair of defective material within the warranty period, when returned freight prepaid to the distributor or their designated service depot.
3. The warranty does not cover damage caused by accident, misuse or faulty installation.
4. The product must be installed and maintained in compliance with the instructions

## EXPLODED AND PARTS LIST

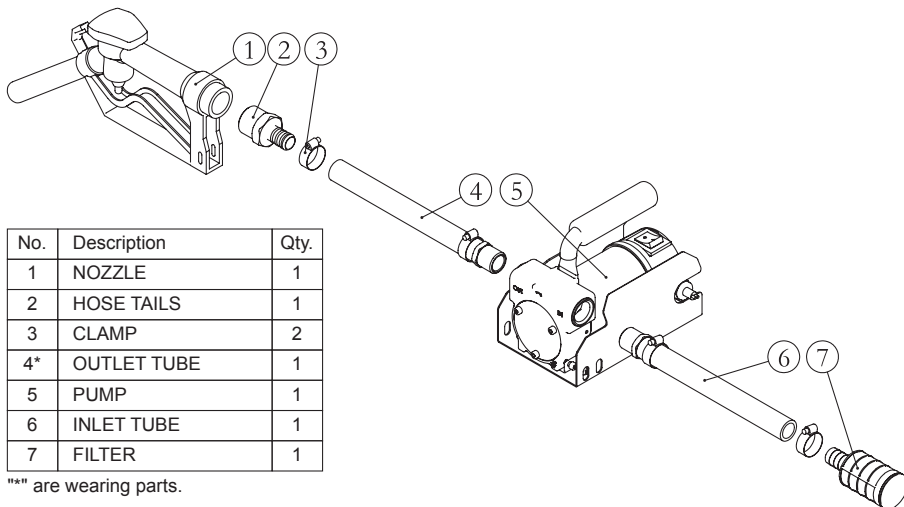

No.	Description	Qty.
1	NOZZLE	1
2	HOSE TAILS	1
3	CLAMP	2
4*	OUTLET TUBE	1
5	PUMP	1
6	INLET TUBE	1
7	FILTER	1

\* are wearing parts.

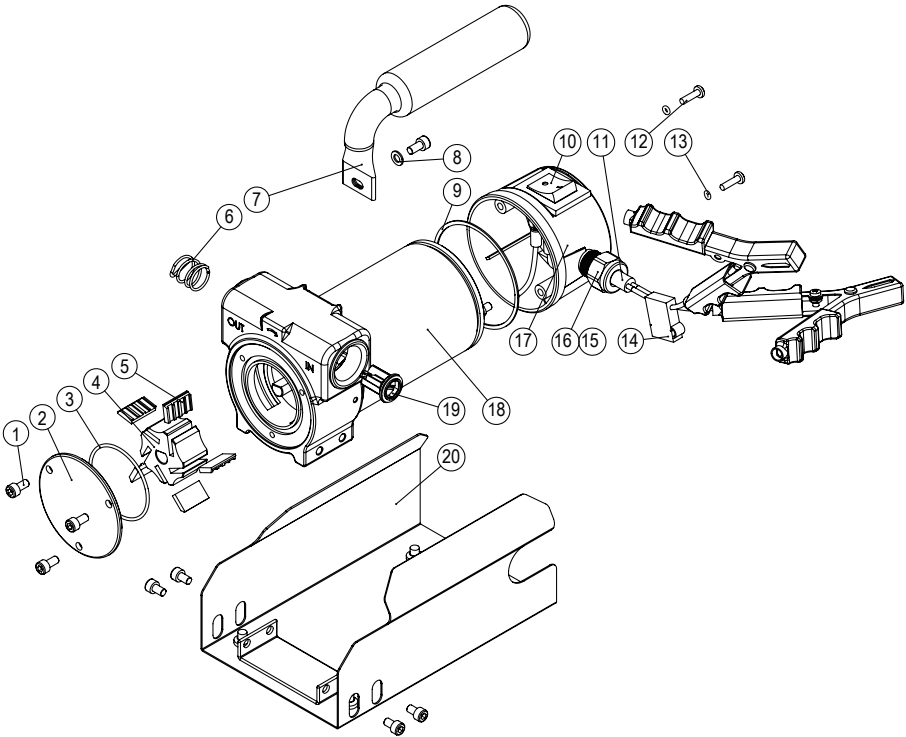

No.	Description	Qty.	No.	Description	Qty.
1	SCREW M5×10	8	11	POWER LINE	2
2	FRONT COVER	1	12	SCREW M4×15	2
3*	O-RING	1	13	O-RING	2
4	ROTOR	1	14*	FUSE 15A/25A	1
5*	BLADE	5	15	COMPACTION NUT	1
6	BY PASS SPRING	1	16	TAPER RING	1
7	HANDLE	1	17	TERMINAL BOARD	1
8	WASHER	1	18	MOTOR 12V/24V	1
9	SEAL	1	19	BY PASS VALVE	1
10	SINGLE-POLE SWITCH	1	20	BASE	1

\*\* are wearing parts.



**Macnaught Americas**  
**(813) 628-5506 | [info@macnaughtusa.com](mailto:info@macnaughtusa.com)**

\* Read Manual Before Use!