

DIFFERENTIAL FLOW COMPUTER

WITH TEMPERATURE COMPENSATION FOR CORRECTED LIQUID VOLUME AND AND PULSE SIGNAL OUTPUTS



Advantages

- Robust IP67 (NEMA Type4X) field enclosure. It is so rugged, **you can even stand on it!**
- Intrinsically Safe available - ATEX and IECEx approval for gas and dust applications.
- Programming can be done by your own crew, with the sensible menu-driven structure, saving cost and irritation. **Know one, know them all!**
- Very diverse mounting possibilities: walls, pipes, panels or directly onto outdoor sensors!

Features

- Displays compensated consumption (flow rate), total and accumulated total.
- Supply and return line: display temperature and compensated flow rate.
- Large 17mm (0.67") digit selection for flow rate or total.
- 7 digit resettable total, 11 digit accumulated total.
- Auto backup of settings and running totals.
- Explosion/flame proof available.
- Full Modbus communication RS232 /485 /TTL.
- Loop or battery powered, 8 - 24V AC/DC or 115 - 230V AC power supply.
- Sensor supply 3 / 8.2 / 12 / 24V DC.
- LED backlight option.

Signal output

- (0)4 - 20mA / 0 - 10V DC according to compensated consumption (flow rate).
- Scaled pulse output according to differential / sum accumulated total.
- Negative or decreasing total indication.

Signal input

Flow

- Ability to process all types of flowmeter signals: Reed-switch, NAMUR, NPN/PNP pulse, Sine wave (coil) or Active pulse signals.

Temperature

- PT100 - 2 or 3 wire.

Applications

- The F-Series is your first and safest choice for field mount indicators in safe and hazardous area applications. Especially in harsh weather conditions like rain, snow, salty atmospheres and temperatures between -40°C up to +80°C (-40°F up to 176°F).
- Fuel consumption calculation for diesel engines on board of ships or locomotives, generators or burners. Alternative basic model: F116. For DIN panel mount indicators, check our D-Series.

General information

Introduction

The flowcomputer Model F127 has been developed to calculate corrected differential liquid volume at normal conditions for generic products. A typical application is the measurement of fuel consumption by engines for power generators, e.g. on board ships and locomotives. The usual difficulties encountered in such applications include: pulsating flows, very low consumption readings, vibration and high ambient temperatures. These are all well catered for in the design and operation of the F127. The corrected volumetric flow in each line is calculated using the thermal expansion coefficient algorithm stored in the flowcomputer. The reference temperature can be defined as desired, e.g. 15°C, 20°C or 60°F.

Display

The display has large 17mm (0.67") and 8mm (0.31") digits which can be set to show flow rate, total and temperature. On-screen engineering units are easily configured from a comprehensive menu. The accumulated total registers up to 11 digits and is backed-up in EEPROM memory every minute.

Configuration

All configuration settings are accessed via a simple operator menu which can be password protected. Each setting is clearly indicated with an alphanumerical description, which avoids confusing abbreviations and baffling codes. Once familiar with one F-series product, you will be able to program all models in the series without a manual. All settings are safely stored in EEPROM memory in the event of sudden power failure.

Analog output signal

The calculated consumption (flow rate) is re-transmitted with the (0)4 - 20mA or 0 - 10V DC output signal. The output signal is updated eight times per second with a filter function being available to smoothen out the signal if desired. The output value is user defined in relation to the flow rate, e.g. 4mA equals to 15L/Hr and 20mA equals to 2000L/Hr. The output signal can be passive, active or isolated where the passive output type will loop power the F127 as well.

Pulse, negative / decreasing total output

One scaleable pulse output, reflects the count on the accumulated display. The second output is configurable as pulse, negative or decreasing total

output. The pulse length is user defined and the maximum output frequency is 500Hz. The output signal can be a passive NPN, active PNP or an isolated electro-mechanical relay.

Signal inputs

The flowcomputer measures the uncorrected volumetric flow and temperature in both supply and return line. The F127 will accept most pulse input signals for flow. For the temperature measurement, 2 or 3 wire PT100 elements can be used.

Communication

All process data and settings can be read and modified manually or through the Modbus communication link (RS232 / RS485). Full Modbus functionality remains available for the Intrinsically Safe version (TTL).

Hazardous area

This model has been ATEX and IECEx certified Intrinsically Safe for gas and dust applications, with an allowed ambient temperature of -40°C to +70°C (-40°F to +158°F). A flame proof Ex d enclosure with ATEX certification is also available.

Enclosures

Various types of enclosures can be selected, all ATEX and IECEx approved. As standard the F127 is supplied in an GRP panel mount enclosure. Most popular is our rugged aluminum field mount enclosure with IP67 / NEMA Type4X rating. Both European or U.S. entry threads are available.

Overview application F127

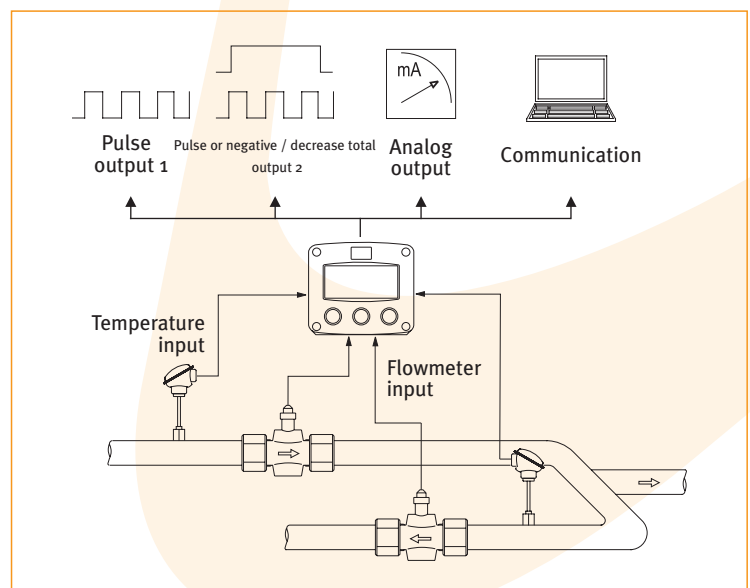

Dimensions enclosures Aluminum & GRP panel mount enclosure

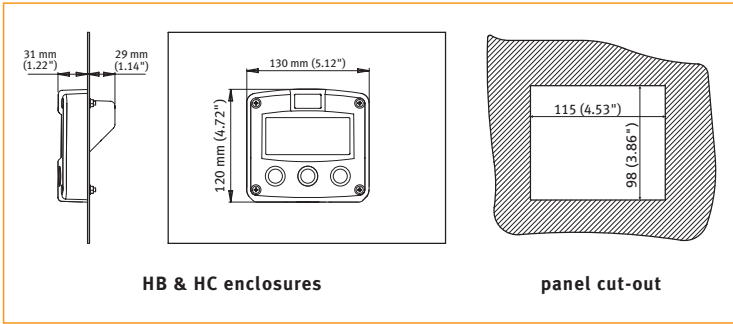

Aluminum & GRP field / wall mount enclosures

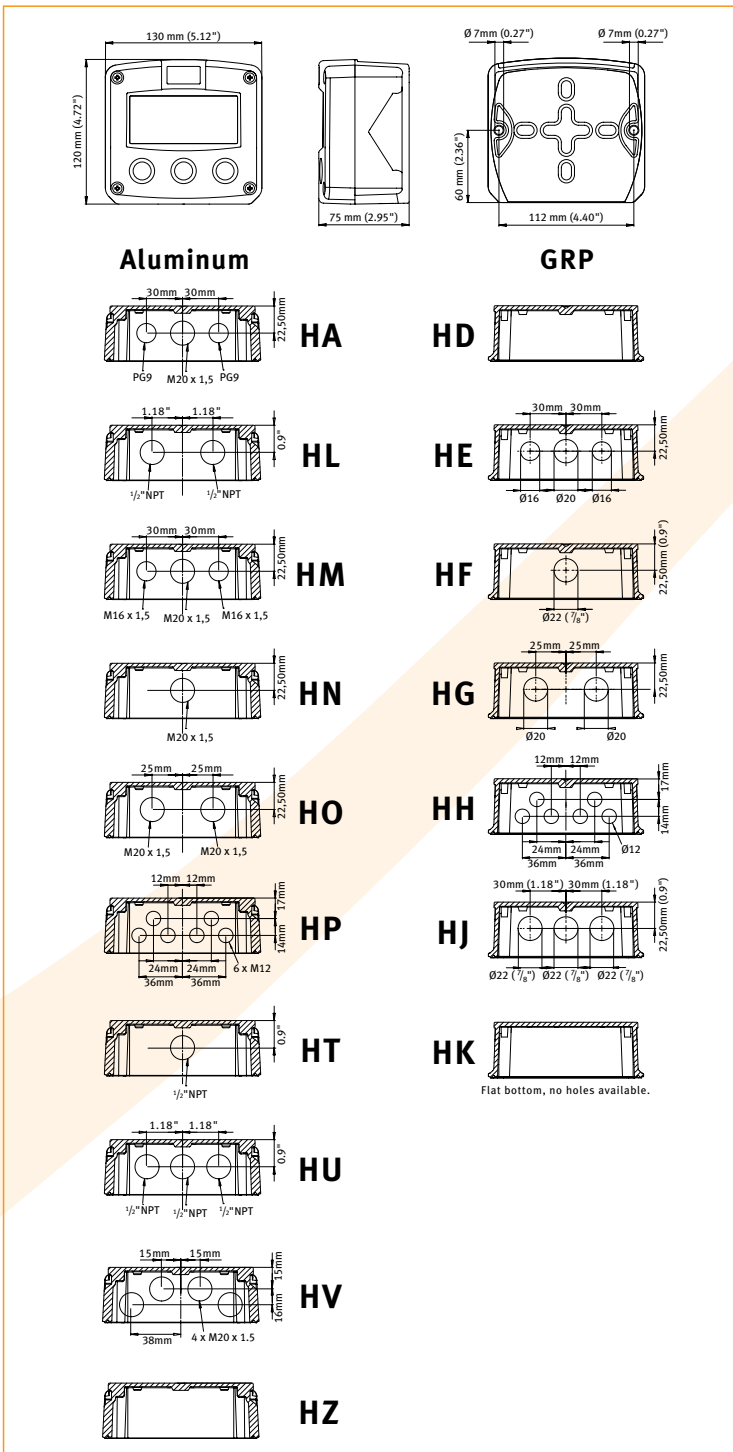

Terminal connections

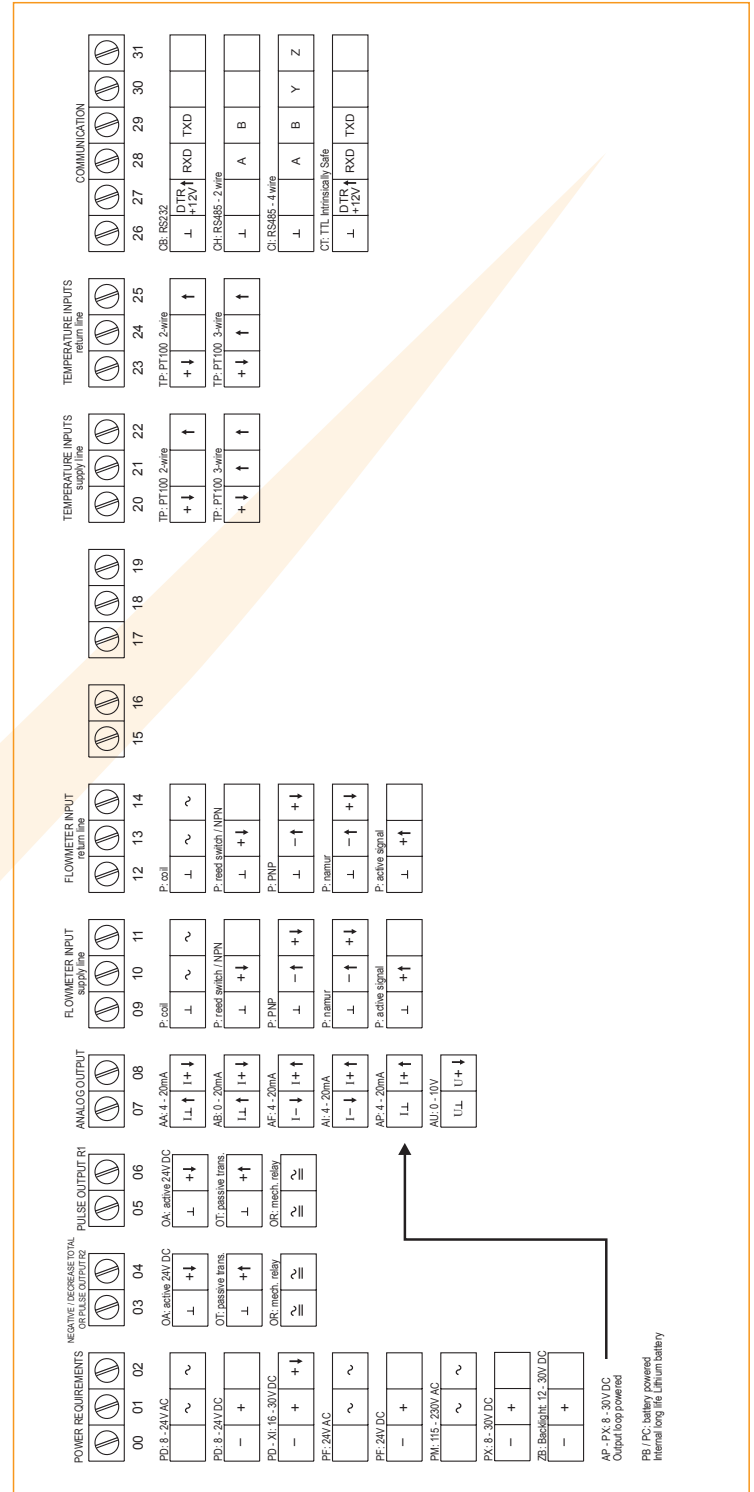

Display example - 90 x 40mm (3.5" x 1.6")

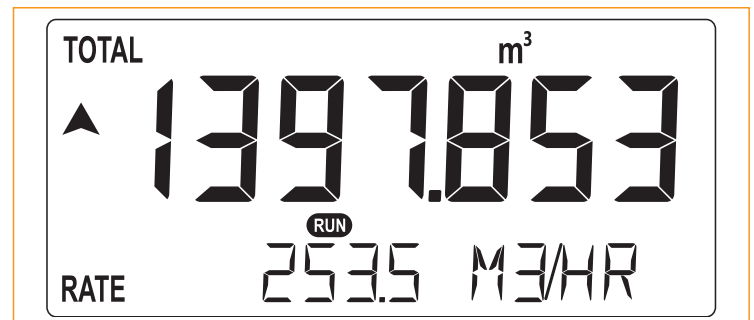

Typical wiring diagram F127-P-(AP)-CH-EL-OT-PB-(PX)-TP

Typical wiring diagram F127-P-AP-CH-EL-OT-PX-TP

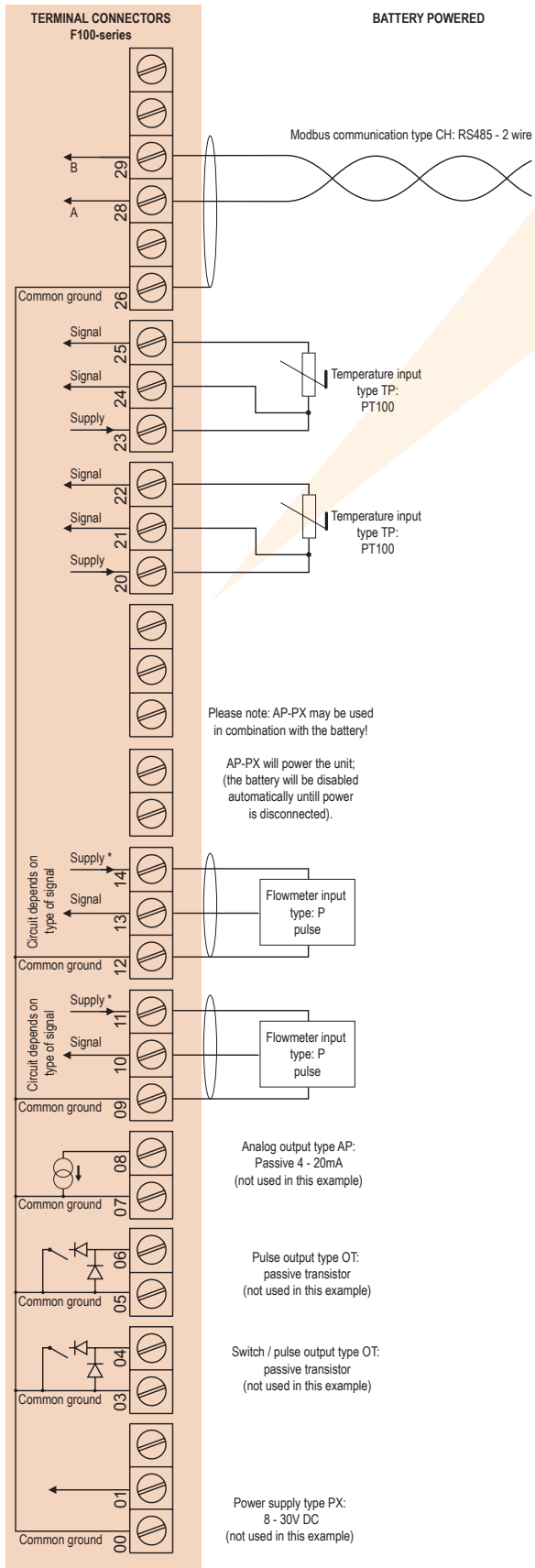

* For pulse type inputs: V_{ref} : 1.2V/3.0V available.- NO power output, available I_{supply} : <1mA. Note: using these ref. voltages at max. load, will reduce battery life significantly.

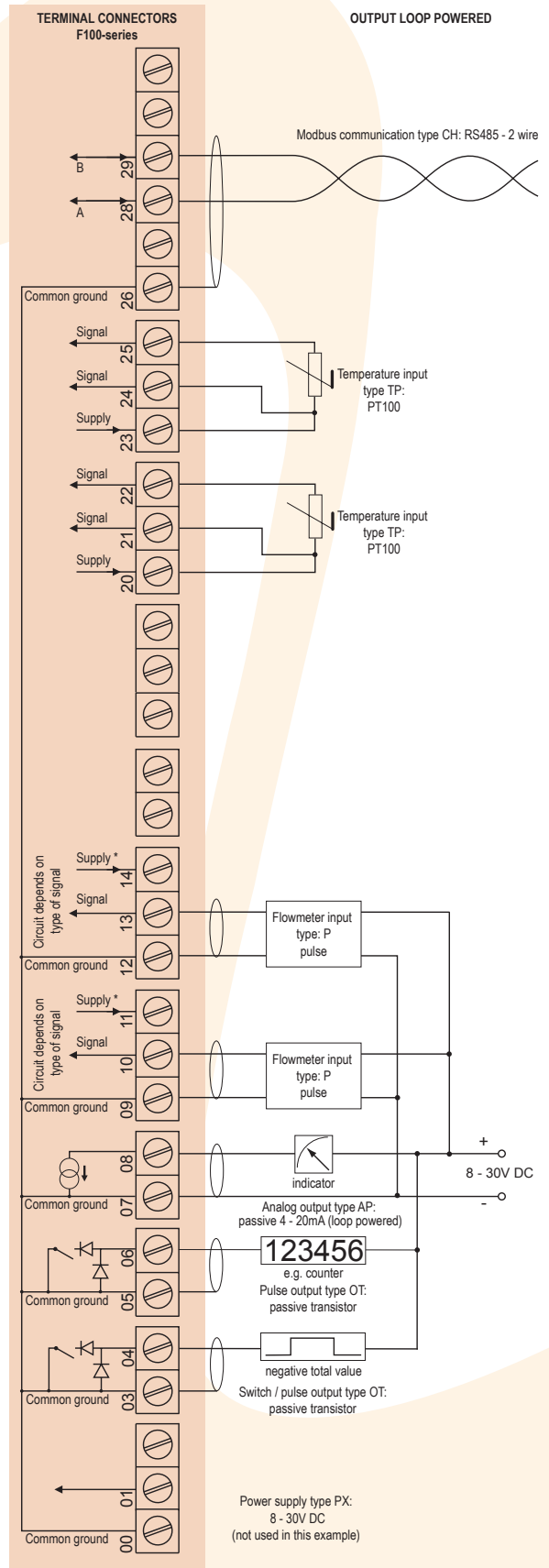

* For pulse type inputs: V_{ref} : 1.2V/3.0V available.- NO power output, available I_{supply} : <1mA. Note: using these ref. voltages at max. load, will reduce battery life significantly.

Typical wiring diagram F127-P-AI-CI-EL-OA-PD-TP

Typical wiring diagram F127-P-AA-CB-EL-OR-PM-TP

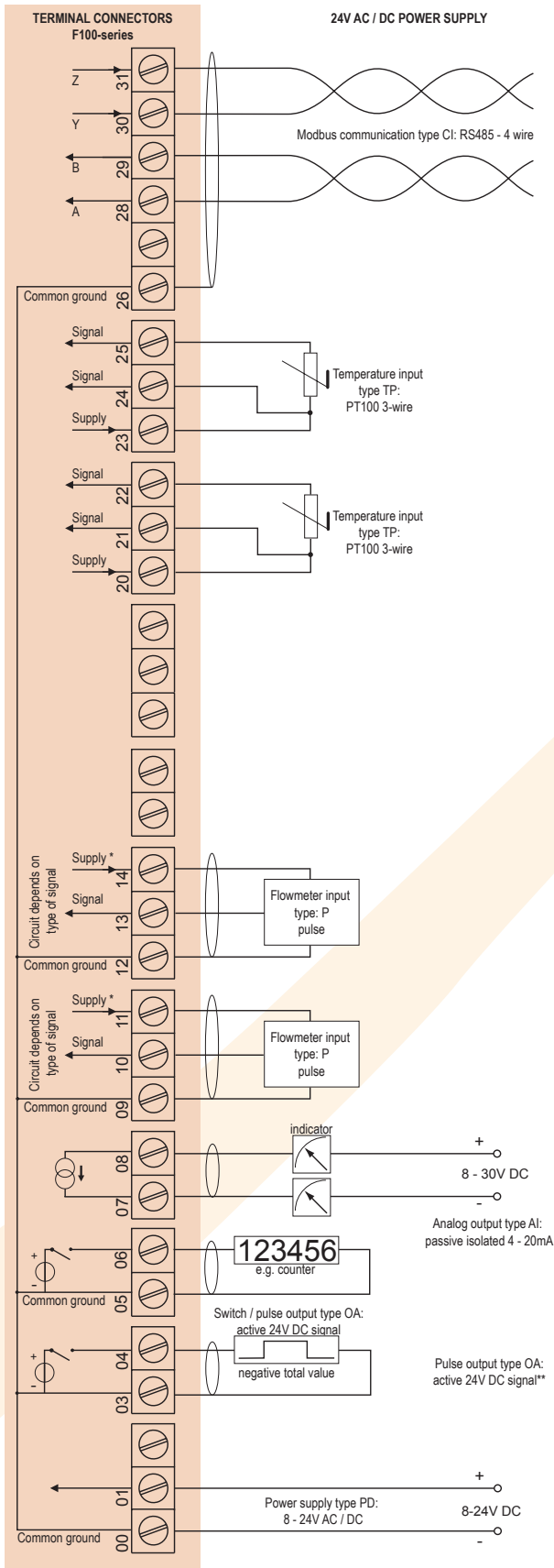

* U_{max} sensor is 2V below U_{supply}
 U_{max} sensor: 8.2V requires 10VDC(8VAC) U_{supply}
 12V requires 14VDC(10VAC) U_{supply}
 24V requires 26VDC(18VAC) U_{supply}

** Requires min. 24V power supply

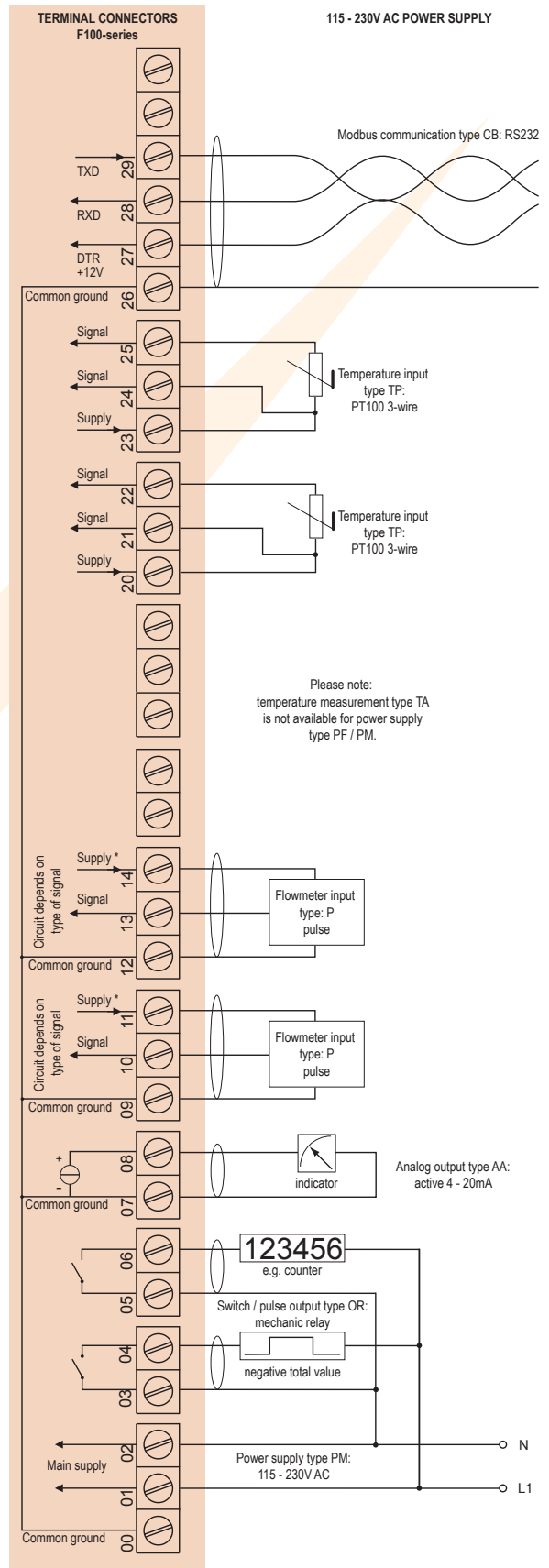

Please note:
 temperature measurement type TA
 is not available for power supply
 type PF / PM.

*Supply voltage: 1.2 / 3.2 / 8.2 / 12 / 24V DC to sensor

Hazardous area applications

The F127-XI has been certified according ATEX and IECEx by DEKRA for use in Intrinsically Safe applications with an ambient temperature of -40°C to +70°C (-40°F to +158°F).

- The ATEX markings for gas and dust applications are:

II 1 G Ex ia IIB/IIC T4 Ga
II 1 D Ex ia IIIC T100 °C Da.

- The IECEx markings for gas and dust applications are: **Ex ia IIC/IIB T4 Ga** and **Ex ia IIIC T100 °C Da.**

It is allowed to connect up to eight I.S. power supplies in IIB/IIIC applications or one I.S. power supply in IIC applications. Consult the certificate for the maximum input and output values of the circuits. Full functionality of the F127 remains available, including 4 - 20mA output according to the flow rate and Modbus communication (type CT). Power supply type PD-XI offers a 8.2V sensor supply e.g. for two Namur sensors.

An ATEX approved flame proof Ex d enclosure is available as well. Please contact your supplier for further details.

Certificate of conformity KEMA 03ATEX1074 X

- IECEx DEK 11.0042X

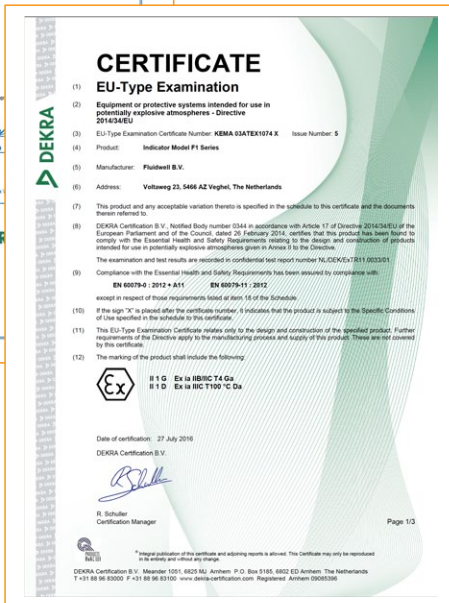
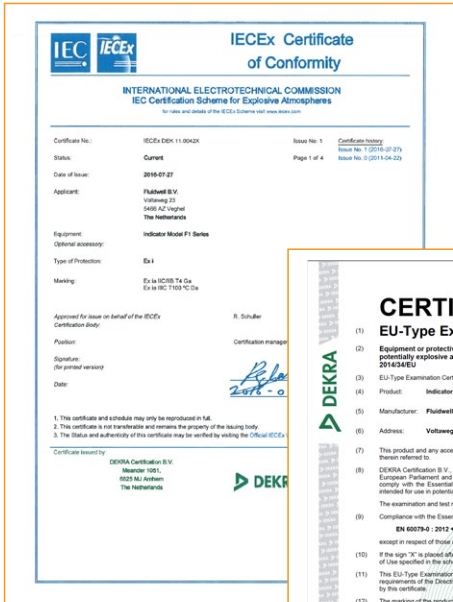

Configuration example IIB / IIIC and IIC F127-P-(AP)-(CT)-EL-TP-(OT)-PC-XI - Battery powered unit

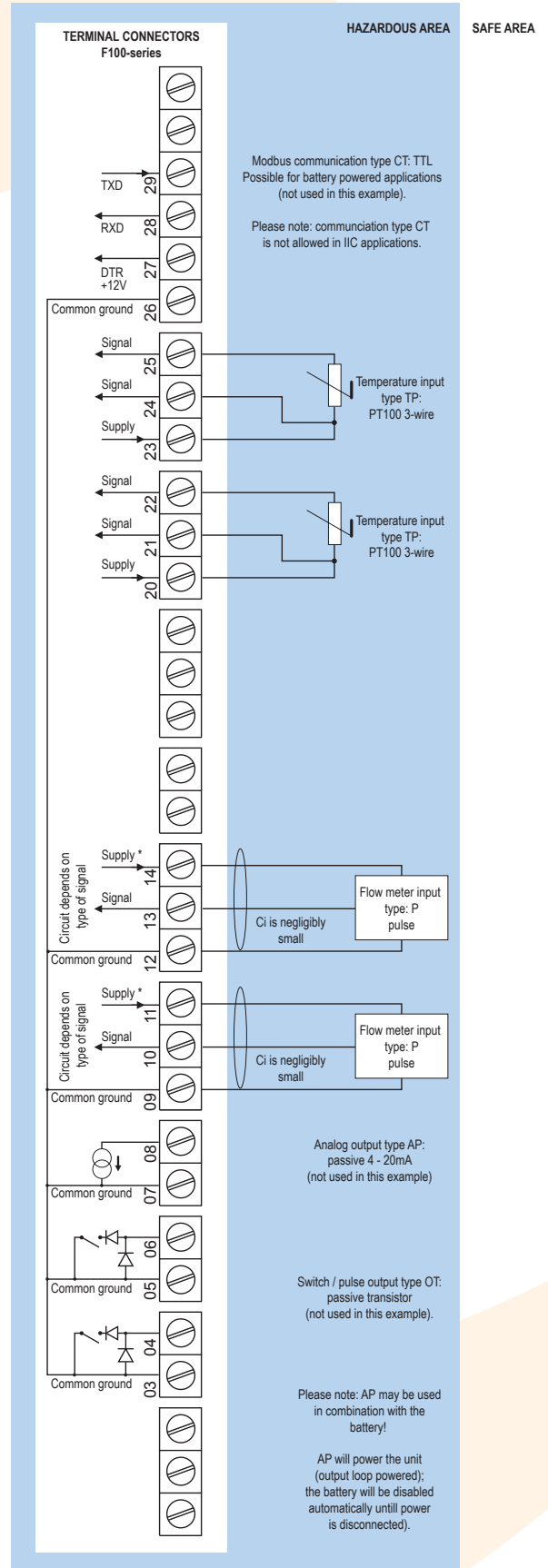

* For pulse type inputs: V_{ref} : 1.2V/3.0V available.- NO power output, available $I_{supply} < 1mA$.
Note: using these ref. voltages at max. load, will reduce battery life significantly.

Configuration example IIB / IIC and IIC - F127-P-AP-CT-EL-OT-(PX)-TP-XI - Output loop powered

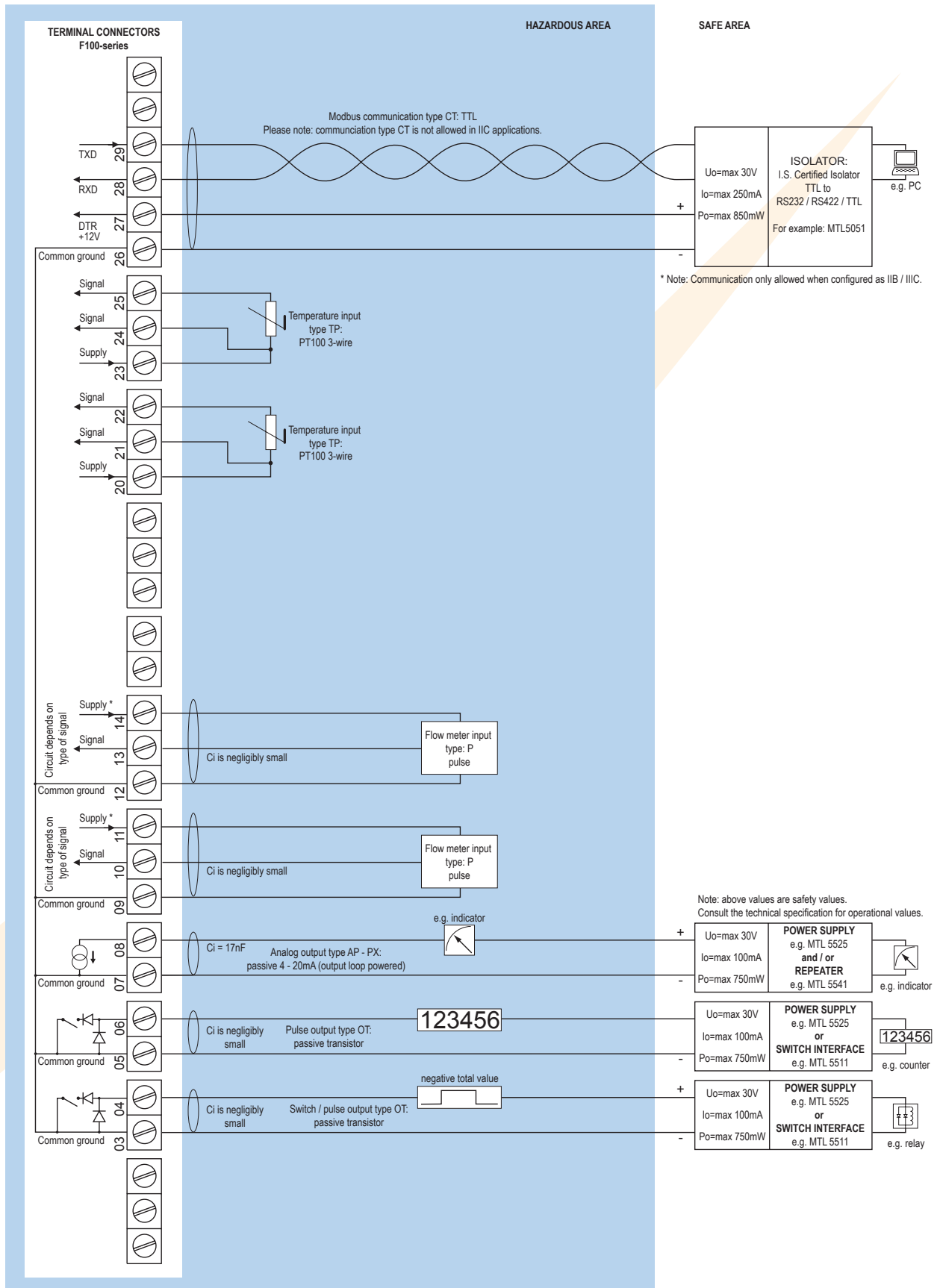

* For pulse type inputs: V_{ref} : 1.2V/3.0V available, - NO power output, available I_{supply} : <1mA.
Note: using these ref. voltages at max. load, will reduce battery life significantly.

Technical specification

General

Display	
Type	High intensity reflective numeric and alphanumeric LCD, UV-resistant.
Dimensions	90 x 40mm (3.5" x 1.6").
Digits	Seven 17mm (0.67") and eleven 8mm (0.31") digits. Various symbols and measuring units.
Refresh rate	User definable: fast, 1sec, 3sec, 15sec, 30sec, off.
Option ZB	Transflective LCD with white LED-backlight. Good readings in full sunlight and darkness.
Note ZB	Only available for safe area applications.

Ambient temperature

Safe areas	-40°C to +80°C (-40°F to +176°F).
Intrinsically Safe	-40°C to +70°C (-40°F to +158°F).

Power requirements

Type AP	Analog output loop powerd, 8 - 30V DC. Power consumption max 0.5 Watt.
Type PB	Long life Lithium battery - life-time depends upon settings and configuration - up to 5 years. (requires PD or PX)
Type PC	Intrinsically Safe long life lithium battery - life-time depends upon settings and configuration - up to 5 years. (requires XI and PD or PX)
Type PD	8 - 24V AC / DC ± 10%. Power consumption max. 5 Watt. Intrinsically Safe: 16 - 30V DC; power consumption max. 1 Watt.
Type PF	24V AC / DC ± 10%. Power consumption max. 15 Watt.
Type PM	115 - 230V AC ± 10%. Power consumption max. 15 Watt.
Type PX	8 - 30V DC. Power consumption max. 0.75 Watt.
Type ZB	12 - 30V DC ± 10%. Power consumption max. 1.5 Watt.
Note PB/PF/PM	Not available Intrinsically Safe.
Note PF/PM	The total consumption of the sensors and outputs may not exceed 400mA @ 24V.
Note	For Intrinsically Safe applications, consult the safety values in the certificate.

Sensor excitation

Type PB/PC/PX	3V DC for pulse signals and 1.2V DC for coil pick-up.
Note	This is not a real sensor supply. Only suitable for sensors with a very low power consumption like coils (sine wave) and reed-switches.
Type PD	1.2 / 3 / 8.2 / 12 / 24V DC - max. 50mA @ 24V DC. U _{max} sensor is 2V below U _{supply}
Type PD-XI	1.2 / 3 / 8.2V DC - max. 7mA @ 8.2V DC and mains power supply voltage (as connected to terminal 1).
Type PF / PM	1.2 / 3 / 8.2 / 12 / 24V DC - max. 400mA @ 24V DC.

Terminal connections

Type	Removable plug-in terminal strip. Wire max. 1.5mm ² and 2.5mm ² .
------	---

Data protection

Type	EEPROM backup of all settings. Backup of running totals every minute. Data retention at least 10 years.
Password	Configuration settings can be password protected.

Directives & Standards

EMC	Directive 2014/30/EU, FCC 47 CFR part 15.
Low voltage	Directive 2014/35/EU
RoHS	Directive 2011/65/EU
ATEX / IECEx	Directive 2014/34/EU, IEC 600079-0, IEC 60079-11.
IP & NEMA	EN 60529 & NEMA 250

Enclosure

General	
Window	Polycarbonate window.
Sealing	Silicone.
Control keys	Three industrial micro-switch keys. UV-resistant silicone keypad.

Aluminum wall / field mount enclosures

General	Die-cast aluminum wall/field mount enclosure IP67 / NEMA Type4X with 2-component UV-resistant coating.
Dimensions	130 x 120 x 75mm (5.12" x 4.72" x 2.95") - W x H x D.
Weight	1100 gr.
Type HA	Cable entry: 2 x PG9 and 1 x M20.
Type HL	Cable entry: 3 x 1/2" NPT.
Type HM	Cable entry: 2 x M16 and 1 x M20.
Type HN	Cable entry: 1 x M20.
Type HO	Cable entry: 2 x M20.
Type HP	Cable entry: 6 x M12.
Type HT	Cable entry: 1 x 1/2" NPT.
Type HU	Cable entry: 3 x 1/2" NPT.
Type HV	Cable entry: 4 x M20.
Type HZ	Cable entry: no holes.

GRP wall / field mount enclosures



General	GRP wall/field mount enclosure IP67 / NEMA Type4X, UV-resistant and flame retardant.
Dimensions	130 x 120 x 75mm (5.12" x 4.72" x 2.95") - W x H x D.
Weight	600 gr.
Type HD	Cable entry: no holes.
Type HE	Cable entry: 2 x Ø 16mm and 1 x Ø 20mm.
Type HF	Cable entry: 1 x Ø 22mm (7/8").
Type HG	Cable entry: 2 x Ø 20mm.
Type HH	Cable entry: 6 x Ø 12mm.
Type HJ	Cable entry: 3 x Ø 22mm (7/8").
Type HK	Flat bottom, cable entry: no holes.

Panel mount enclosures

Dimensions	130 x 120 x 60mm (5.12" x 4.72" x 2.36") - W x H x D.
Panel cut-out	115 x 98mm (4.53" x 3.86") L x H.
Type HB	Die-cast aluminum panel mount enclosure IP65 / NEMA Type4X.
Weight	600 gr.
Type HC	GRP panel mount enclosure IP65 / NEMA Type4X, UV-resistant and flame retardant.
Weight	450 gr.

Hazardous area

Intrinsically Safe (Type XI)

ATEX certification	 II 1 G Ex ia IIB/IIC T4 Ga. II 1 D Ex ia IIIC T100 °C Da.
IECEx certification	 Ex ia IIC/IIB T4 Ga. Ex ia IIIC T100 °C Da.
Ambient Ta	-40°C to +70°C (-40°F to +158°F).

Explosion proof (Type XF)

ATEX certification	 II 2 G / Ex d IIB T5 Gb. II 2 D / Ex t IIIB T100 °C Db.
Type XF	Dimensions of enclosure: 300 x 250 x 200mm (11.8" x 9.9" x 7.9") L x H x D.
Weight	Appr. 15kg.
Note	IECEx available on request.

Signal inputs

Flowmeter

Type P	Coil / sine wave (HI: 20mVpp or LO: 80mVpp - sensitivity selectable), NPN/PNP, open collector, reed-switch, Namur, active pulse signals 8, 12 and 24V DC.
Frequency	Minimum 0 Hz - maximum 7 kHz for total and flow rate. Maximum frequency depends on signal type and internal low-pass filter. E.g. reed switch with low-pass filter: max. frequency 120 Hz.
K-Factor	0.000010 - 9,999,999 with variable decimal position.
Low-pass filter	Available for all pulse signals.
Option ZF	coil sensitivity 10mVpp.

Temperature

Update time	One time per two seconds.
Type TP	2 or 3 wire PT100.
Range	-100°C to +200°C (-148°F to 392°F). Accuracy 0.1°C (0.18°F).
Option ZV	Range: -200°C to +800°C (-328°F to 1832°F). Accuracy 0.5°C (0.9°F).

Signal outputs

Communication

Functions	Reading display information, reading / writing all configuration settings.
Protocol	Modbus RTU.
Speed	1200 - 2400 - 4800 - 9600 baud.
Addressing	Maximum 255 addresses.
Type CB	RS232
Type CH	RS485 2-wire
Type CI	RS485 4-wire
Type CT	TTL Intrinsically Safe.

Digital outputs

Function	One pulse output according to differential or sum accumulated total and one configurable pulse, negative or decreasing total output.
Frequency	Max. 500Hz. Pulse length user definable between 0.001 second up to 9.999 seconds.
Type OA	Two active 24V DC transistor outputs (PNP); max. 50mA per output. Requires min. 24V power supply.
Type OR	Two electro-mechanical relay outputs - isolated (N.O.) - max. switch power 230V AC - 0.5A (req. PF or PM).
Type OT	Two passive transistor outputs (NPN) - not isolated. Max. 50V DC - 300mA per output.

Analog output

Function	Transmitting compensated differential flow rate.
Accuracy	10 bit. Error < 0.05%. Analog output signal can be scaled to any desired range.
Update time	eight times per second.
Type AA	Active 4 - 20mA output.
Type AB	Active 0 - 20mA output.
Type AF	Passive floating 4 - 20mA output for Intrinsically Safe applications (requires XI + PD).
Type AI	Passive galvanically isolated 4 - 20mA output - also available for battery powered models.
Type AP	Passive 4 - 20mA output - not isolated. Unit will be loop powered.
Type AU	Active 0 - 10V DC output. Requires min. 12V power supply.

Operational

Operator functions

Displayed function	<ul style="list-style-type: none">• Compensated differential flow rate (consumption).• Compensated differential total and acc. total.• Supply line - Inlet temperature and comp. flow rate.• Return line - Outlet temp. and comp. flow rate.• Total can be reset to zero by pressing the CLEAR-key twice.
--------------------	---

Total

Digits	7 digits.
Units	L, m ³ , GAL, USGAL, kg, lb, bbl, no unit.
Decimals	0 - 1 - 2 or 3.
Note	Total can be reset to zero.

Accumulated total

Digits	11 digits.
Units / decimals	According to selection for total.
Note	Can not be reset to zero.

Flow rate

Digits	7 digits.
Units	mL, L, m ³ , Gallons, kg, Ton, lb, bl, cf, RND, ft ³ , scf, Nm ³ , NL, ical - no units.
Decimals	0 - 1 - 2 or 3.
Time units	/sec - /min - /hr - /day.

Line temperature

Digits	6 digits.
Units	°C, °F or K.
Decimals	1.

Flow equations

Type EL	Corrected liquid volume.
Formula	$Q_{\text{normal}} = Q \times (1 + \alpha (T_{\text{normal}} - T))$ where α = thermal expansion coefficient.
Normal temperature	Default: 273.15 K - any temperature can be set.

Ordering information

Standard configuration: F127-P-AP-CX-EL-HC-OT-PX-TP-XX-ZX.

Ordering information: F127 -P -A -C -EL -H -O -P -TP -X -Z

Flowmeter input signal

P Pulse: coil, npn, pnp, namur, reed-switch input.

Analog output signal

AA Active 4 - 20mA output.

AB Active 0 - 20mA output.

AF I.S. floating 4 - 20mA output - requires XI + PD.

AI Isolated 4 - 20mA output.

AP **Passive 4 - 20mA output, loop powered unit.**

AU Active 0 - 10V DC output.

Communication

CB Communication RS232 - Modbus RTU.

CH Communication RS485 - 2-wire - Modbus RTU.

CI Communication RS485 - 4-wire - Modbus RTU.

CT Intrinsically Safe TTL - Modbus RTU.

CX **No communication.**

Flow equation

EL **Corrected liquid volume.**

Panel mount enclosures - IP65 / NEMA Type4X

HB Aluminum enclosure.

HC **GRP enclosure.**

GRP field / wall mount enclosures - IP67 / NEMA Type4X

HD Cable entry: no holes.

HE Cable entry: 2 x Ø 16mm & 1 x Ø 20mm.

HF Cable entry: 1 x Ø 22mm (7/8").

HG Cable entry: 2 x Ø 20mm.

HH Cable entry: 6 x Ø 12mm.

HJ Cable entry: 3 x Ø 22mm (7/8").

HK Flat bottom, cable entry: no holes.

Aluminum field / wall mount enclosures - IP67 / NEMA Type4X

HA Cable entry: 2 x PG9 + 1 x M20.

HL Cable entry: 2 x 1/2"NPT.

HM Cable entry: 2 x M16 + 1 x M20.

HN Cable entry: 1 x M20.

HO Cable entry: 2 x M20.

HP Cable entry: 6 x M12.

HT Cable entry: 1 x 1/2"NPT.

HU Cable entry: 3 x 1/2"NPT.

HV Cable entry: 4 x M20.

HZ Cable entry: no holes.

Digital output signals

OA Two active transistor outputs.

OR Two mechanical relay outputs - requires PF or PM.

OT **Two passive transistor outputs - standard configuration.**

Power requirements

PD 8 - 24V AC/DC + sensor supply - in combination with XI: 16 - 30V DC.

PF 24V AC/DC + sensor supply.

PM 115 - 230V AC + sensor supply.

PX **Basic power supply 8 - 30V DC (no real sensor supply).**

Additional battery supply (optional)

PB Lithium battery powered - requires PD or PX.

PC Lithium battery powered - Intrinsically Safe - requires XI, and PD or PX.

Temperature input signal

TP **PT100 input.**

Hazardous area

XI Intrinsically Safe, according ATEX and IECEx.

XF Ex d enclosure - 3 keys according ATEX.

XX **Safe area only.**

Options

ZB Backlight.

ZF Coil input 10mVpp.

ZV PRTD-range -200°C / +800°C.

ZX **No options.**

The bold marked text contains the standard configuration. Available Intrinsically Safe.

Specifications are subject to change without notice.



Fluidwell bv
P.O. Box 6
5460 AA - Veghel - The Netherlands
Telephone: +31 (0)413 343 786
Telefax: +31 (0)413 363 443
email: displays@fluidwell.com
Internet: www.fluidwell.com

