

**BOP20**  
BATTERY OPERATED PUMP

**&**

**BOP60**  
BATTERY OPERATED PUMP

## Instruction Manual

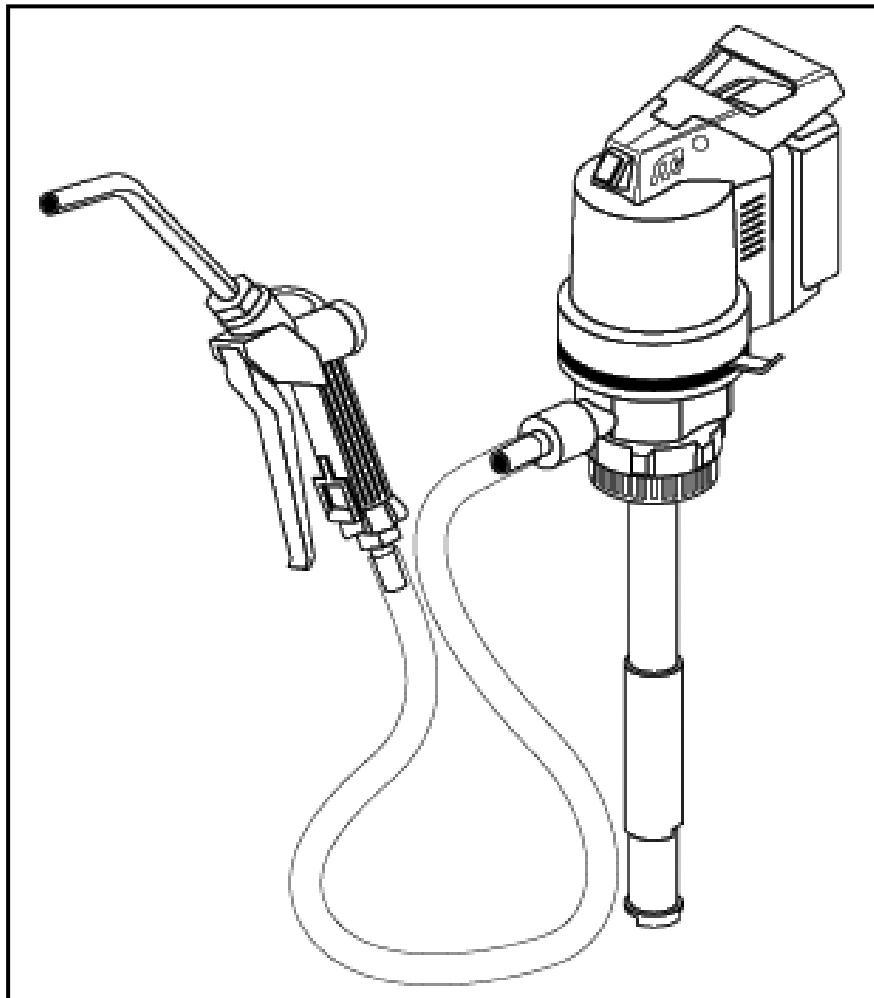

## INTRODUCTION

Thank you for purchasing the Macnaught BOP battery operated pump.

Macnaught has designed and manufactured this pump to the highest quality standards using premium quality materials and workmanship.

**PLEASE READ THIS SAFETY INFORMATION CAREFULLY BEFORE USE.**

Read and retain this instruction manual to assist you in the operation of your new product.



### WARNING

Please read this important information carefully before use.

This product should only be used with automotive oils and lubricants.

- Visually inspect pump, charger and battery prior to use for any signs of damage, loose or missing parts. If equipment is worn or damaged, remove it from service (Replace if required).
- The BOP Battery operated pump must be used strictly in accordance with Macnaught's terms and conditions.
- 'WARNING' listed throughout this manual to advise of actions which may cause damage to your equipment.

Failure to follow all instructions listed below may result in electric shock, fire, serious injury and/or damage to the power tool. The term "power tool" in all of the warnings listed refers to your battery operated (cordless) power tool.

- Make sure all operators have adequate access to the following instructions.



### GENERAL SAFETY

**DO NOT** operate power tools in explosive areas, e.g; close to flammable liquids, gases or dust.



### ELECTRICAL SAFETY

- Never modify electrical connections.
- **DO NOT** expose power tool to rain or wet conditions.
- **DO NOT** use product if the product is damaged or the switch does not turn the pump on.
- **Only use "ORIGINAL" Macnaught replacement parts, battery or charger.**



### BATTERY and CHARGER SAFETY

Please follow instructions from battery and charger owners manual

- If "battery-pack" case is damaged **DO NOT** use - Danger of electric shock or electrocution.
- Battery charger **MUST ONLY** be used for charging the rechargeable batteries supplied with the BOP.
- **DO NOT** operate charger if charger, power cord or plug is damaged - replace immediately.
- **DO NOT** disassemble charger or battery.
- **DO NOT** store battery pack in locations where the temperature may reach or exceed 40°C/104°F.
- **DO NOT** use charger on any other voltage than designated on the charger.

### DISCLAIMER

Your product is designed to use with non-flammable automotive oil/lubricants only, with viscosity grades from 0W-40 to SAE90. Usage with different fluids may cause performance degradation and render the warranty void. Improper use of liquid may lead to machine failure and malfunction.

Use of any flammable fluids can cause sparks to explode and create a fire hazard. Macnaught bears no liability to the consequence of fluid misuse by customers.



## WARNING

- Always place gun on hanger when pump is not in use, as oil spillage can cause a slipping hazard.
- Keep plastic bag away from babies and children.
- Do not lift the power head with locking lever. Handle power head with care. **DO NOT DROP.**
- Make sure the power head is securely connected/attached to the stem.
- Do not leave the power head sitting on top of the stem unlocked.
- Stop operating the battery oil pump if any leakings at the joints are noticed.
- Do not modify the pump in any way.
- Only use a genuine Macnaught dispensing gun. Hand tighten the hose till its firm and check for any signs of leakage before use.
  
- Do not use flammable fluid in this product. Only use fluid specified in this instruction manual.
- Wear appropriate PPE for protection.
- Do not use the product in potentially explosive atmosphere.
- Do not expose the product to fire and source of heat.
- Users should refer to MSDS of the fluid from supplier being used.
- Use product in well ventilated area.
- Never leave your dispensing gun unattended in open position. Do not attempt to use any means to lock the lever. Always ensure the switch is in off position after dispensing the oil.
  
- Use pump in adequate lighting condition for safe operation. Do not use the product under poor illumination.
- Avoid spillage of oil near water source as it may be harmful to the environment.
- When moving drum, check area for spillage and clean up any liquid on floor as this will cause a slippery hazard
- Only use genuine Macnaught battery and chargers with this product.
- Battery pack, charger and power head should be protected from water.



## CAUTION

- \* Do not expose the power head to a nearby magnet as its performance will be adversely affected.
- The battery operated pump should always be used in a vertical position.
- The dispensing gun should always be facing up when dispensing fluid.
- If the noise level changes check the hose to see if there is air present, if air is present stop the pump immediately as this indicates the drum is empty. Switch over to a new drum.

## BATTERY DISPOSAL

**NOTE:** Dispose of old batteries properly. The battery contains rechargeable Lithium-ion and must be recycled or disposed of properly. Please refer to the local authorities for the correct method of battery disposal.



Li-ion



**DO NOT** incinerate the battery pack. The battery can explode in a fire

**DO NOT** attempt to disassemble any battery.

## CHARGE BATTERY

1) Insert battery

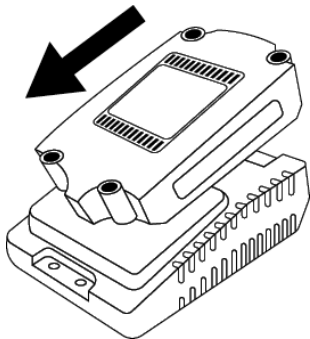

2) Power on  
(green light only)

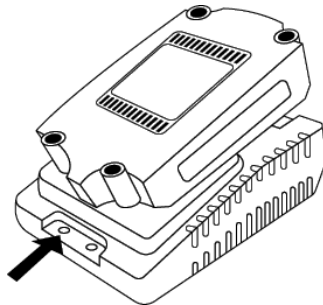

3) Battery charging  
(red light only)

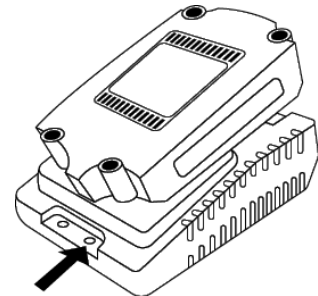

4) Battery charged  
(green light only)

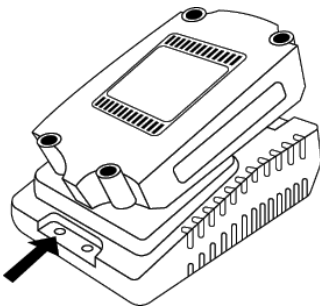

Note: Red light flashes when battery voltage is low  
(trickle charging to prevent battery damage)

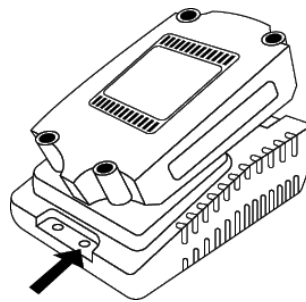

## INSERT / REMOVE BATTERY

1) Insert battery  
a) lift handle  
b) push down

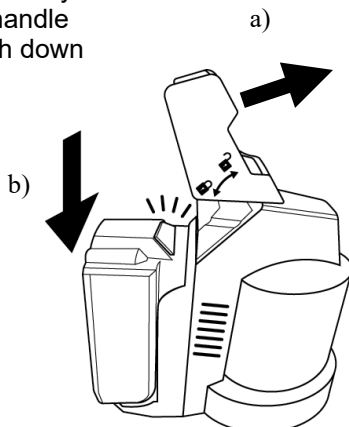

2) Remove battery  
a) lift handle  
b) press button  
c) pull up

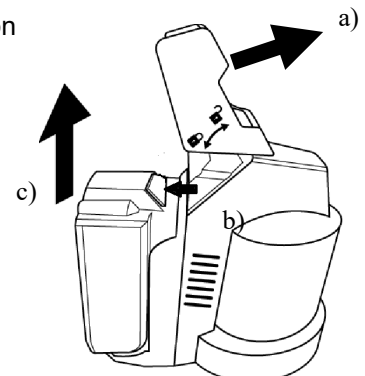

## ASSEMBLY

Note: Remove both the inlet and outlet plugs from the pump stem before use.

1) Pull down extender tube

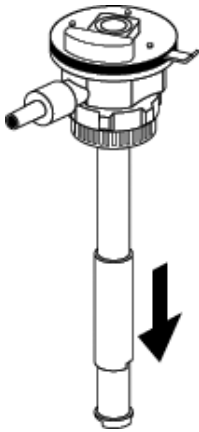

2) Push the pump stem into container

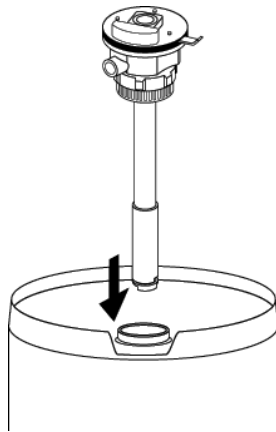

3) Tighten bung adapter to secure pump stem

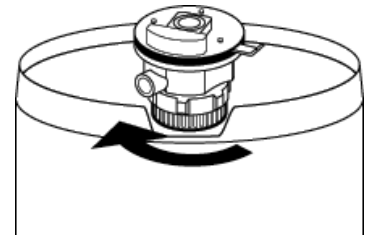

4) Attach hose and gun (ensure end gasket is in place)

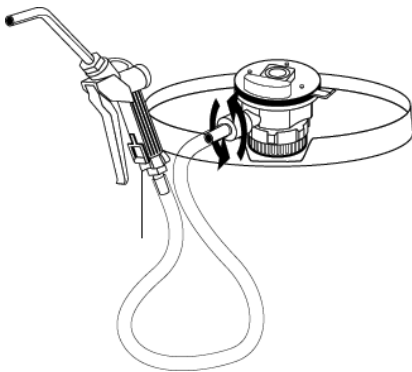

5) Ensure switch is off, then place power head onto pump stem

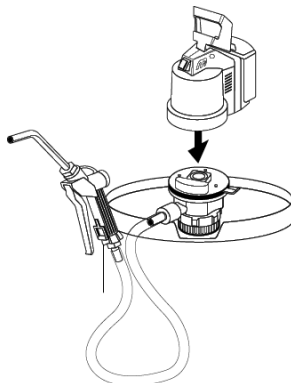

6) Press handle down to lock power head

Note: Power head will not operate unless locked correctly into position.

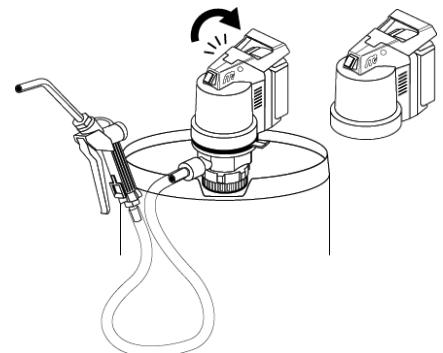

7) Place gun onto hanger when finished

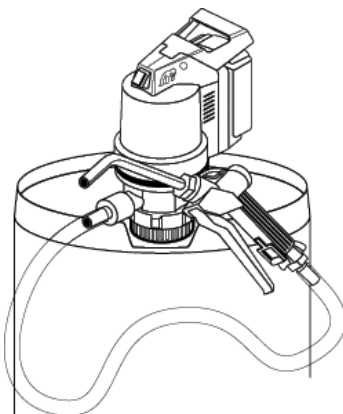

8) To remove power head, lift handle.

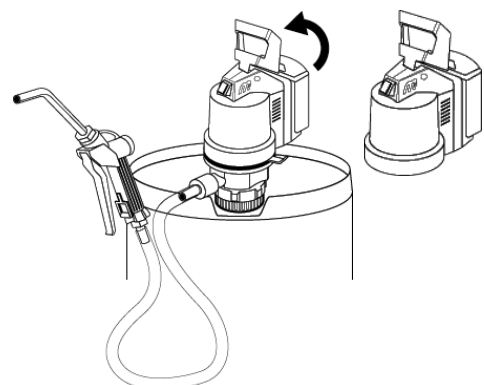

# OPERATING INSTRUCTIONS

## OPERATION



### CAUTION

**NOTE: Do not allow the pump to run dry or pump damage can occur**

#### IMPORTANT:

For initial operation

- 1) Turn slot in shaft clockwise one complete turn with a flat head screwdriver.
- 2) First press the trigger on gun and then turn on the pump to prime. Release trigger when primed (fluid flows from gun).
- 4) Power head can be moved from pump assembly to pump assembly.
- 5) Long storage periods :
  - a) Turn slot shaft 2 full turns counter clockwise using a flat head screwdriver.
  - b) When starting pump after a long storage period, turn slot shaft clockwise with a flat head screwdriver.

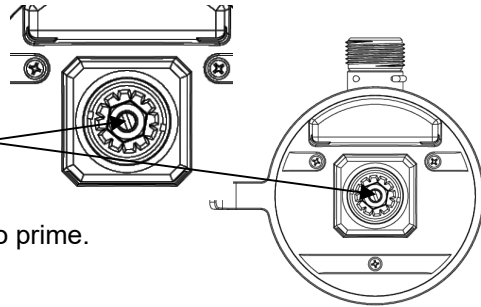

#### Note:

Pump will not run when power head is not attached to pump stem correctly.

Pressure sensor will turn motor off when trigger is released and stall pressure is reached.

If you use the high viscosity pump on low viscosity oils you may need to manually prime the system before use

### GENERAL OPERATION

- 1) Attach power head to stem
- 3) Press or Release trigger to adjust flow



### CAUTION

- 2) Remove nozzle cover before use

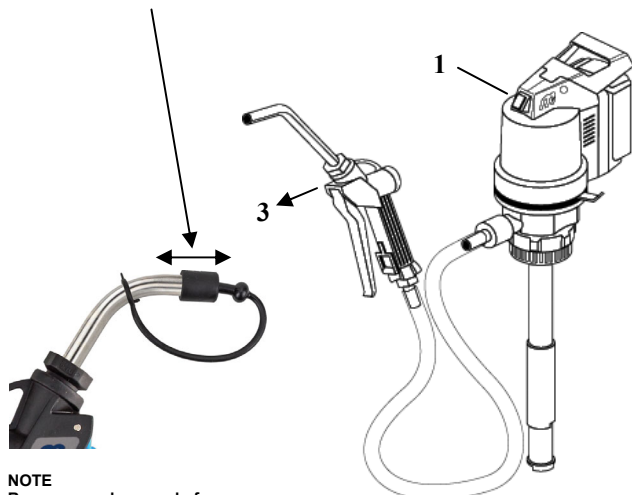

**NOTE**  
Remove nozzle cover before use  
Replace nozzle cover after use

- 4) Lift handle to transfer power head from stem to stem

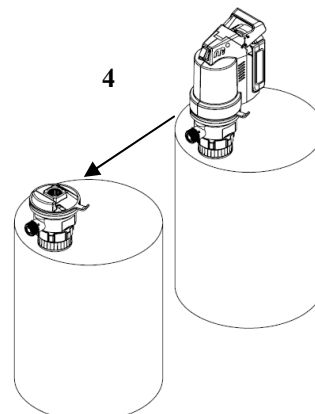

## DIAPHRAGM AND SPRING REPLACEMENT

1) Turn anti-clockwise, remove drive gear

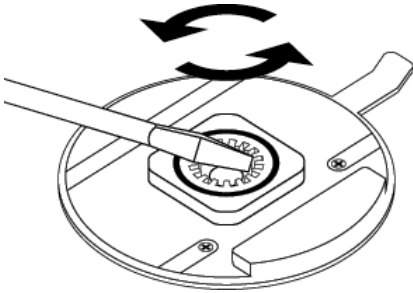

2) Remove 3 screws, pump cover and dispensing gun hanger

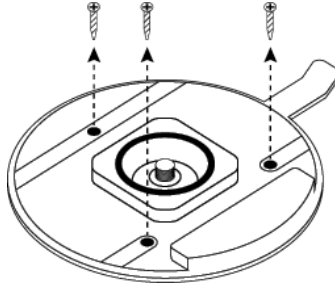

3) Remove 2 screws.

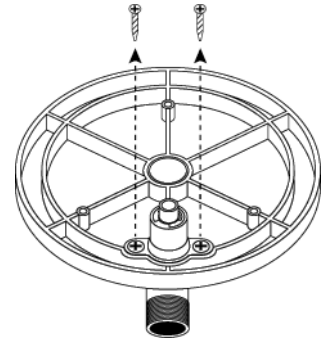

4) Remove assembly.

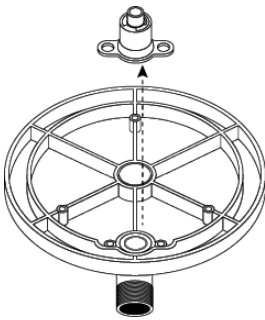

5) Remove circlip.

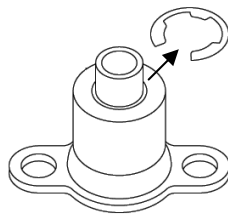

6) Replace spring.

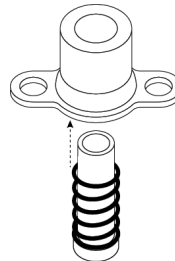

7) Re-fit circlip.

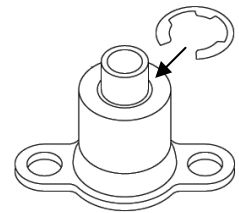

8) Remove old diaphragm.

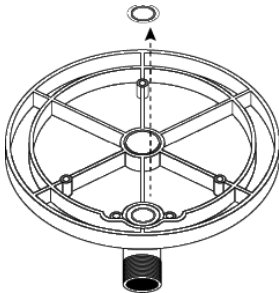

9) Fit new diaphragm. (ensure correct orientation)

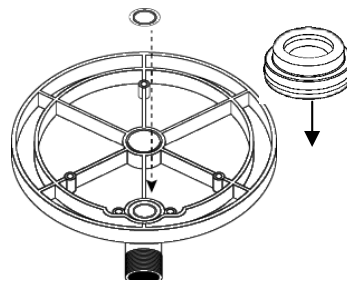

10) Fit valve switch assembly.

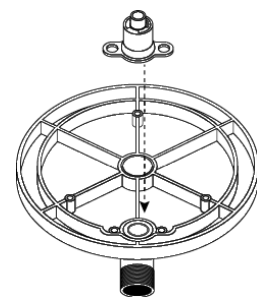

11) Fit 2 screws.

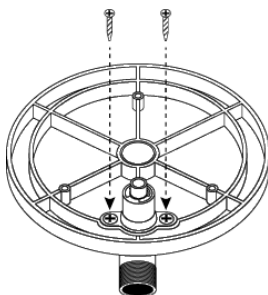

12) Fit pump cover and dispensing gun hanger, using 3 screws.

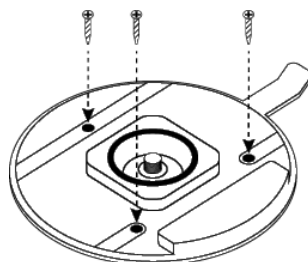

13) Fit drive gear, turn clockwise to secure.

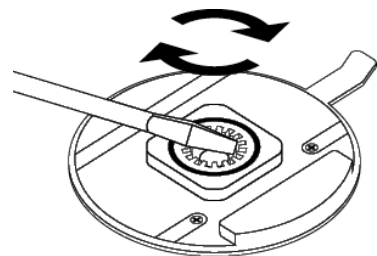

## IMPELLER AND O’RING REPLACEMENT

1) Unscrew adapter

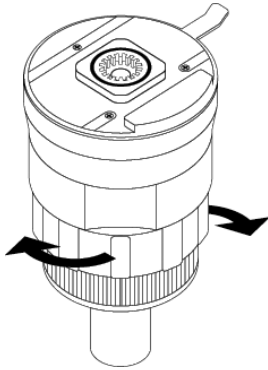

2) Remove o’ring.

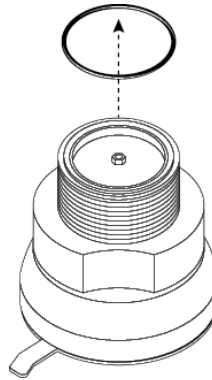

3) Remove impeller housing.

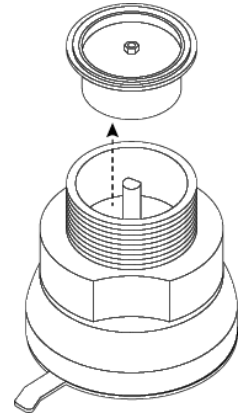

4) Remove o’ring.

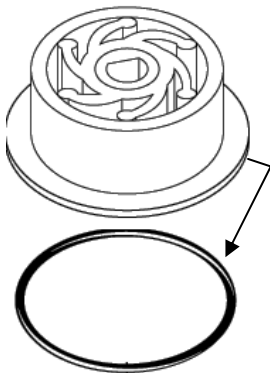

5) Carefully remove and replace impeller.

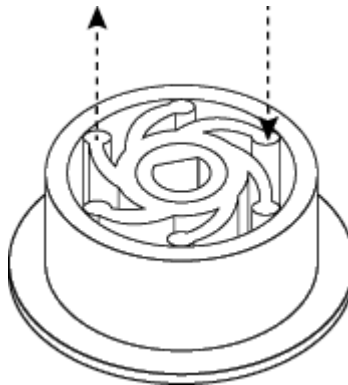

6) Replace o’ring.

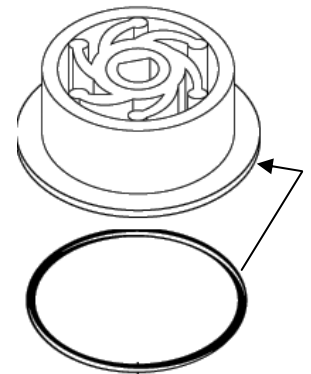

**Note: Impeller must be lubricated with oil or grease during assembly.**

7) Carefully insert impeller housing.  
(Note correct orientation of grooves)

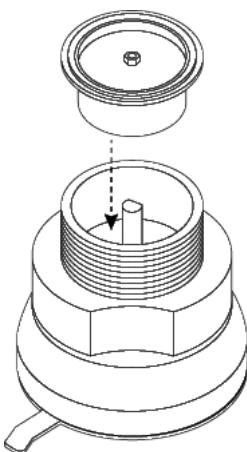

8) Replace o’ring.

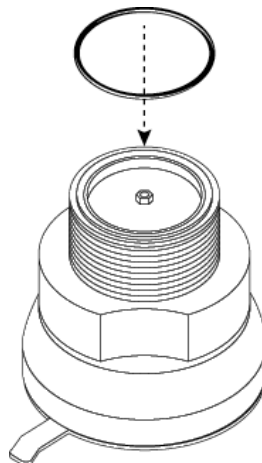

9) Firmly hand tighten pump tube.

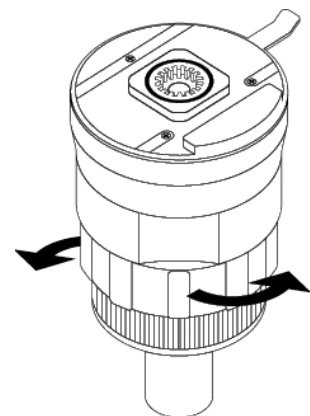



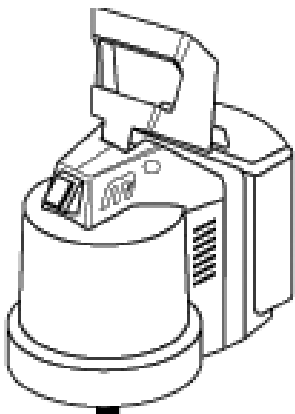

**Note:** Power head is factory sealed and would need to be replaced if found to be damaged internally or externally.

## Spare parts list

Item no	Pump Kit Ref			No off	Description
	Standard BP-1K	High Vis / ATF BP-2K	Coolant BP-3K		
	A	B	C		<b>Pump Seal Kit</b>
1				1	Nut (M6)
2				1	Connector
3				3	Screws (3.5 x 25)
4				1	Top pump stem cover
5				1	Dispensing gun hanger
6	A	B	C	1	Circlip
7				2	Screws (3.6 x 16)
8	A	B	C	1	Spring
9	A	B	C	1	Plunger
10	A	B	C	1	Diaphragm
11				1	Pressure switch housing
12				1	Housing - pump stem
13				1	Ball
14				1	Spring
15				1	Connector (outlet body)
16				1	U-Clip
17	A	B	C	1	Impeller cover
18	A	B	C	1	Impeller
19	A	B	C	1	O'ring
20	A	B	C	1	Impeller housing
21	A	B	C	1	O'ring
22				1	Bung adapter (type C)
23				1	Suction tube assembly
24				1	Drive shaft
25	A	B	C	1	O'ring
26				1	Spring
27	A	B	C	1	O'ring
28				1	Check valve

### Gun / Hose set

BP-HG - Standard / ATF / Coolant  
BP-HGHV - High Viscosity

### Sealt kits

Standard pump - includes parts listed (A) - BP-1K  
Hi Viscosity / ATF - includes parts listed (B) - BP-2K  
Coolant pump - includes parts listed (C) - BP-3K

Bung Adapter Set 20ltr - order BP20-AK  
60ltr - order BP60-AK

Bung Adapter for 20ltr drum with pull out spout - order BP037s

## EXPLODED DIAGRAM

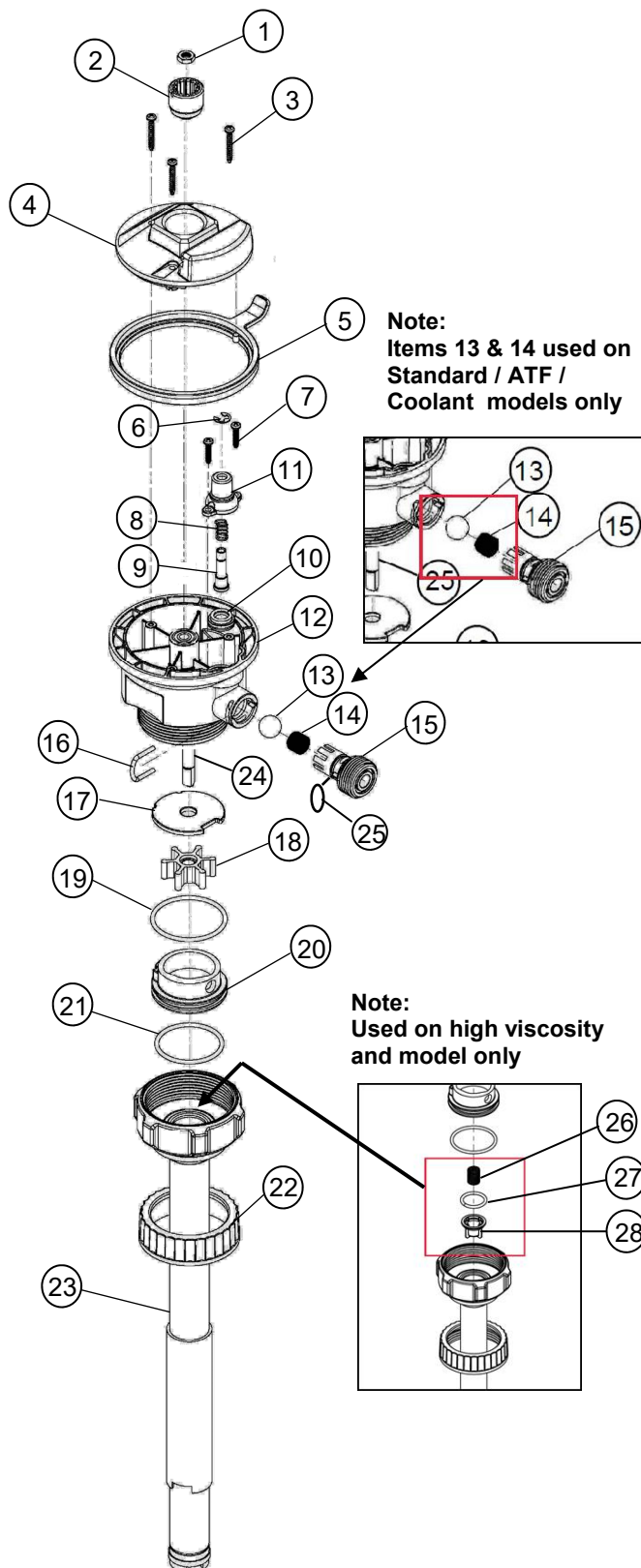

# TROUBLESHOOTING GUIDE

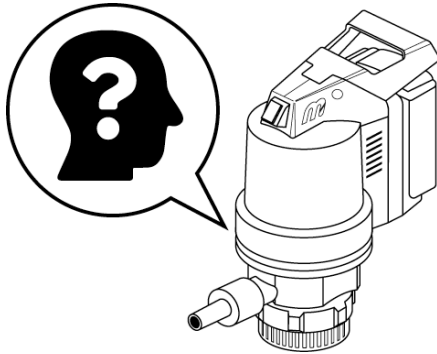

TROUBLE	CAUSE	REMEDY
<p><b>Pump does not turn on</b></p>	<ul style="list-style-type: none"> <li>a) Flat battery</li> <li>b) Power head not attached correctly to pump</li> <li>c) Faulty switch</li> <li>d) Pump stem failure</li> </ul>	<ul style="list-style-type: none"> <li>a) Recharge battery</li> <li>b) Re-fit power head correctly</li> <li>c) Contact supplier</li> <li>d) Contact supplier</li> </ul>
TROUBLE	CAUSE	REMEDY
<p><b>Pump will not prime</b></p>	<ul style="list-style-type: none"> <li>a) Pump tube plug has not been removed before use.</li> <li>b) Damaged or worn impeller</li> <li>c) No oil in container</li> <li>d) Damaged gun or hose</li> <li>e) Damaged diaphragm</li> </ul>	<ul style="list-style-type: none"> <li>a) Remove tube plug</li> <li>b) Fit new impeller <b>Note: Do not let the impeller run dry</b></li> <li>c) Check oil level in container</li> <li>d) Replace gun</li> <li>e) Replace diaphragm</li> </ul>
TROUBLE	CAUSE	REMEDY
<p><b>Power head does not stop when gun trigger is released</b></p>	<ul style="list-style-type: none"> <li>Damaged diaphragm or spring</li> <li>Damaged or worn impeller</li> <li>Gun leaking</li> <li>Damaged hose</li> </ul>	<ul style="list-style-type: none"> <li>Replace damaged diaphragm or spring</li> <li>Replace impeller</li> <li>Replace gun</li> <li>Replace hose</li> </ul>

## SPECIFICATIONS

	Low to Medium Viscosity Oil	High Viscosity Oil
Flowrate	* 3.5 l/min (0W-40 @ 20 deg C)	*2 l/min (85W-140 @ 20 deg C)
Operating Temperature	0°C - 40°C (32°F - 104°F)	10-40 deg C
Container Size	Models available to suit 20ltr and 60ltr containers	
Fluid compatibility	Automotive oils / Lubricants	
Max Viscosity	SAE 0W40 to 75W90	Up to SAE 85W-140
Self Priming	Yes	
Shut off Pressure up to	20psi	15psi
Hose	12.5mm x 1.5m (5ft) wire reinforced PVC	19mm x 1.5m (5ft) wire reinforced PVC
Warranty - Pump and Power Head	2 Years	
Warranty - Battery	12 Months	
Wetted components	Nitrile rubber, Mild steel, Stainless steel, Nylon, Brass, Polypropylene, Zinc plated steel	
Relative humidity	50% - 90%	
Hook Colour	Black	Yellow

	ATF Model	Coolant Model
Flowrate	* 4.5 l/min (ATF @ 20 deg C)	* 5.8 l/min @ 20 deg C
Operating Temperature	0°C - 40°C (32°F - 104°F)	
Container Size	Models available to suit 20ltr and 60ltr containers	
Fluid compatibility	ATF	Coolant (Premix or Concentrate)
Max Viscosity	ATF	Coolant
Self Priming	Yes	
Shut off Pressure up to	15psi	
Hose	12.5mm x 1.5m (5ft) wire reinforced PVC	
Warranty - Pump and Power Head	2 Years	
Warranty - Battery	12 Months	
Wetted components	Nitrile rubber, Mild steel, Stainless steel, Nylon, Brass, Polypropylene, Zinc plated steel	Nitrile rubber, Mild steel, Stainless steel, Nylon, Brass, Polypropylene, PPS
Relative humidity	50% - 90%	
Hook Colour	Red	Green

\* Flow rates are a guide only and any variations can depend on temperature and fluid viscosity

## Available Kits and Packs

<b>Low to Medium Viscosity oil</b>	Australia	US	JAP	UK	EU
Starter Kit - 20ltr	BP20S-OLA	BP20S-OLU	BP20S-OLJ	BP20S-OLB	BP20S-OLE
Starter Kit - 60ltr	BP60S-OLA	BP60S-OLU	BP60S-OLJ	BP60S-OLB	BP60S-OLE
Battery	BPB-20AH				
Power Head	BP20-PH				
Battery Charger	BPC-A	BPC-U		BPC-B	BPC-U

<b>Low to Medium Viscosity oil</b>	Australia	US	JAP	UK	EU
Pump Stem - 20ltr	BP20X-OLA		BP20X-OLJ	BP20X-OLB	BP20X-OLE
Pump Stem - 60ltr	BP60X-OLA				

<b>High Viscosity</b>	Australia	US	JAP	UK	EU
Starter Kit - 20ltr	BP20S-OHA	BP20S-OHU	BP20S-OHJ	BP20S-OHB	BP20S-OHE
Starter Kit - 60ltr	BP60S-OHA	BP60S-OHU	BP60S-OHJ	BP60S-OHB	BP60S-OHE
Battery	BPB-20AH				
Power Head	BP20-PH				
Battery Charger	BPC-A	BPC-U		BPC-B	BPC-U

<b>High Viscosity</b>	Australia	US	JAP	UK	EU
Pump Stem - 20ltr	BP20X-OHA		BP20X-OHJ	BP20X-OHB	BP20X-OHE
Pump Stem - 60ltr	BP60X-OHA				

### ATF

Pump Stem - 20ltr	BP20X-ALA
Pump Stem - 60ltr	BP60X-ALA

### COOLANT

Pump Stem - 20ltr	BP20X-COA
-------------------	-----------

## COMPLIANCE

### MBC-US – US Battery Charger

This battery charger has been tested & verified by ETL Intertek to meet OSHA required safety standard.



### FCC:

This device complies with Part 15 of the FCC Rules. Operation is subject to the following two conditions:

- (1) this device may not cause harmful interference, and (2) this device must accept any interference received, including interference that may cause undesired operation.

Warning: Changes or modifications to this unit not expressly approved by the party responsible for compliance could void the user's authority to operate the equipment.

NOTE: This equipment has been tested and found to comply with the limits for a Class B digital device, pursuant to Part 15 of the FCC Rules. These limits are designed to provide reasonable protection against harmful interference in a residential installation. This equipment generates, uses and can radiate radio frequency energy and, if not installed and used in accordance with the instructions, may cause harmful interference to radio communications. However, there is no guarantee that interference will not occur in a particular installation. If this equipment does cause harmful interference to radio or television reception, which can be determined by turning the equipment off and on, the user is encouraged to try to correct the interference by one or more of the following measures:

- Reorient or relocate the receiving antenna.
- Increase the separation between the equipment and receiver.
- Connect the equipment into an outlet on a circuit different from that to which the receiver is connected.
- Consult the dealer or an experienced radio/ TV technician for help.



### EC Declaration of Conformity

**We:** Macnaught Pty. Ltd. **Of:** 41-49 Henderson Street, Turrella NSW 2205, Australia.

**Declare that:** Battery operated oil pump BP20S-OL-w (-w: A-Z; i.e. B = Britain, E = Europe)  
**which consists the following assemblies/components:**  
 Power Head BP20-PH  
 Stem Assemblies & Hose Set BP20X-OL-x (-x: A-Z; i.e. B = Britain, E = Europe)  
 Li-Ion Battery Charger MBC-yyz (-y, -z: A-Z; i.e. AU = Australia, EU = Europe, US = USA)  
 Li-Ion Battery MBP2000MAH  
 (Lower case w, x, y and z are used as variables to represent country specific models)

**In accordance with:**

Machinery Directive	2006/42/EC
Low Voltage Directive	2014/35/EU
Electromagnetic Compatibility Directive	2014/30/EU
Restriction of Hazardous Substance Directive	2011/65/EU as amended by 2015/863/EU
Waste Electrical and Electronic Equipment Directive	2012/19/EU
Battery Directive	2006/66/EC as amended by 2013/56/EU

have been designed and manufactured to the applicable harmonised standards below:

	EN ISO 12100: 2010
(BP20S-OL-w)	EN 809: 1999+A1: 2009/AC: 2010
(BP20-PH)	EN55014-1: 2017
(BP20X-OL-x)	EN55014-2: 2015
	EN60204-1: 2006+A1: 2009/AC: 2010
	EN60335-1: 2012+A11: 2014
	EN60335-2-29: 2004+A2: 2010
	EN62233: 2008
(MBC-yyz)	EN55014-1: 2006+A1:2009+A2:2011
	EN55014-2: 2015
	EN61000-3-2: 2014
	EN61000-3-3: 2013
	EN62133-2: 2017
(MBP2000MAH)	EN55032: 2015
	EN55035: 2017

I hereby declare that the equipment named above has been designed to comply with the relevant sections of the above referenced specification. The product complies with all essential requirements of the Directives.

Signature 

Name: Marco Uccellani Position: Engineering Manager

Done at: 41-49 Henderson Street, Turrella NSW 2205, Australia. Date: 20/Mar/2019



**Notes:**

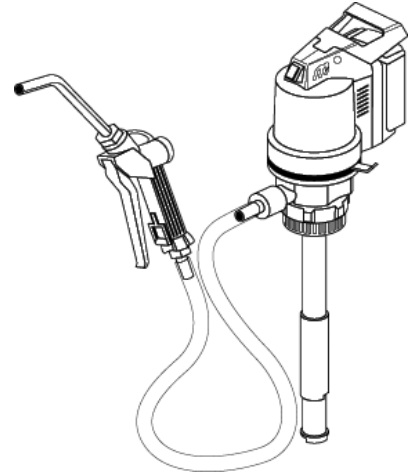

**macnaught**

**Head Office - Australia  
Macnaught Pty Limited**  
ABN 66 000 075 785

41-49 Henderson St  
Turella, NSW, 2005  
Sydney, Australia.

**T:** +61 2 9567 0401  
**F:** +61 2 9597 7773  
**W:** [www.macnaught.com.au](http://www.macnaught.com.au)

**Macnaught USA Inc  
(North & South America)**  
614 South Ware Blvd. Tampa,  
Florida, 33619 United States.

**T:** +1813 628 5506  
**F:** +1813 628 5506  
**E:** [info@macnaught.com](mailto:info@macnaught.com)  
**W:** [www.macnaughtusa.com](http://www.macnaughtusa.com)

**Note:**

This product should be disposed of according to all applicable local and national government environment regulations and guidelines.



**For Warranty Terms and Conditions see [macnaught.com.au](http://macnaught.com.au)**  
**For a list of Australian Service Centres see [macnaught.com.au](http://macnaught.com.au)**