

# macnaught

## Double Guide Arm Spring Driven Safety Hose Reel Instruction Manual

---

### Slow Retraction Series



#### **WARNING:**

Read carefully and understand all **INSTRUCTIONS** before operating. Failure to follow the safety rules and other basic safety precautions may result in serious personal injury. Save these instructions in a safe place and on hand so that they can be read when required. Keep these instructions to assist in future servicing.

---



## GENERAL SAFETY REGULATIONS



**WARNING:** The warnings, cautions, and instructions discussed in this instruction manual cannot cover all possible conditions or situations that could occur. It must be understood by the operator that common sense and caution are factors that cannot be built into this product, but must be supplied by the operator.

1. Keep the work area clean and dry. Damp or wet work areas can result in injury.
2. Keep children away from work area. Do not allow children to handle this product.
3. Use the right tool for the job. Do not attempt to force small equipment to do the work of larger industrial equipment. There are certain applications for which this equipment was designed. It will do the job better and more safely at the capacity for which it was intended. Do not modify this equipment, and do not use this equipment for a purpose for which it was not intended.
4. Check for damaged parts. Before using this product, carefully check that it will operate properly and perform its intended function. Check for damaged parts and any other conditions that may affect the operation of this product. Replace damaged or worn parts immediately.
5. Do not overreach. Keep proper footing and balance at all times to prevent tripping, falling, back injury, etc.
6. DO NOT use the equipment when tired or under the influence of drugs, alcohol, or medication. A moment of inattention while operating this equipment may result in serious personal injury.

## TECHNICAL DETAILS

SKU#	Inlet/Outlet	Working Pressure	Hose Working Temperature	Hose Capacity		
				Material	I.D.	Length
M3D-SSAW-5050	1/2" NPT	300PSI	-4°F ~ +140°F	NBR	1/2"	50ft
M3D-SSCO-5050	1/2" NPT	2320PSI	-40°F~+210°F	SAE R1	1/2"	50ft
M3D-SSAW3850-H	3/8" NPT	300PSI	-4°F~+140°F	Hybrid Polymer	3/8"	50ft
M3D-SSAW5050-H	1/2" NPT	300PSI	-4°F~+140°F	Hybrid Polymer	1/2"	50ft
M3D-SSAW3850	3/8" NPT	300PSI	-4°F~+140°F	NBR	3/8"	50ft
M3D-SSG-7550	1/4" NPT	5800PSI	-40°F~+210°F	SAE R2	1/4"	50ft

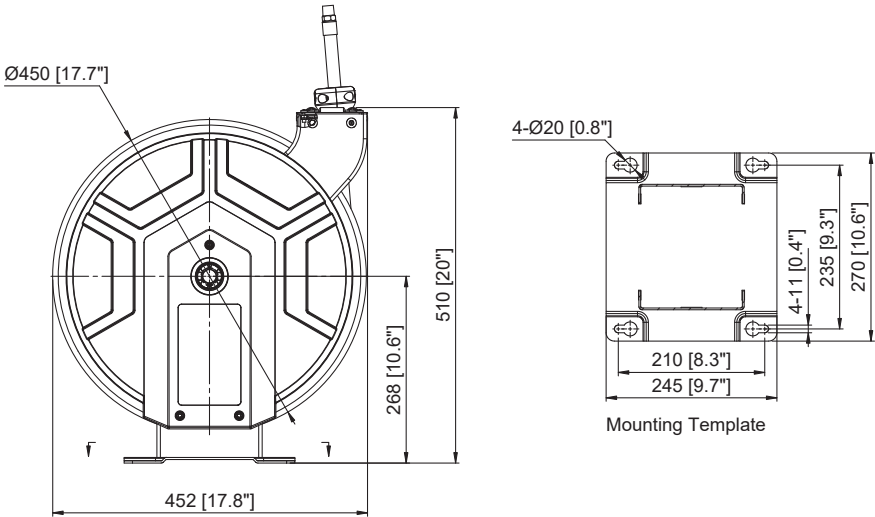

### Description

1. This series of hose reel is professional spring-driven model.
2. This series of hose reel is equipped with safety slow retraction function.
3. This series of hose reel can be pulled and stopped at any point during usage.

### Tips:

1. Read the following precautions and instructions before you begin assembly or using.
2. Failure to comply with these instructions could result in personal injury or property damage.
3. Keep these instructions in a convenient location for future reference.

## SAFETY PRECAUTIONS

1. Make sure incoming line pressure does not exceed rated operating pressure for your model hose reel.
2. Use proper eye protection when assembling and using the hose reel.
3. Keep children away from the work area.
4. For long-time nonuse, please empty the hose.
5. If long-term preservation of the hose reel, please check whether the hose is aging and whether the connecting valve is leaking.

**⚠ WARNING:** Exposure of skin directly to pressurized air, or fluid could result in severe bodily injury.

## INSTALLATION INSTRUCTIONS

### Prepare tools for installation

For overhead ceiling and wall mounting: The installation height should not exceed 3m(10 feet) above the floor.

If the reel you have purchased does not have hose included, you will need to purchase and attach. Refer to specifications to determine appropriate hose and size.

1. The reel base has four 7/16"(or 11mm) drilled holes for mounting on a suitable flat surface. Figures 1.1 to 1.2 is a template showing the correct location of the 4 mounting holes in the base.
2. The reel is supplied with a hose guide roller bracket. The bracket position may require repositioning depending on the selected reel mounting position. Figure 2.1 shows "Typical Mounting Positions". If bracket position needs to be changed, do the following:
  - (1) Pull out some hose and let reel latch.
  - (2) Remove side cover and guide arm.
  - (3) Rotate guide roller bracket to correct position, replace bolts and tighten.
3. Using the four holes in the base, mount the reel in the desired location. Be sure to use appropriate hardware and tighten securely.
4. Apply Teflon tape or pipe sealant to supply line threads, attach to reel inlet and tighten. The other end of incoming line can now be connected to desired supply source.
5. If hose has been supplied with reel: Apply Teflon tape or pipe sealant to outlet fitting on reel hose, then attach to desired tool, or nozzle. Check connection for leakage, also check hose reel for correct operation. (Details see Operation section.)
6. If hose stopper adjustment is required, pull hose from reel and allow to latch at desired length. Loosen stopper bolts and slide stopper to a position close to the hose guide. Tighten stopper bolts, and unlatch the reel.

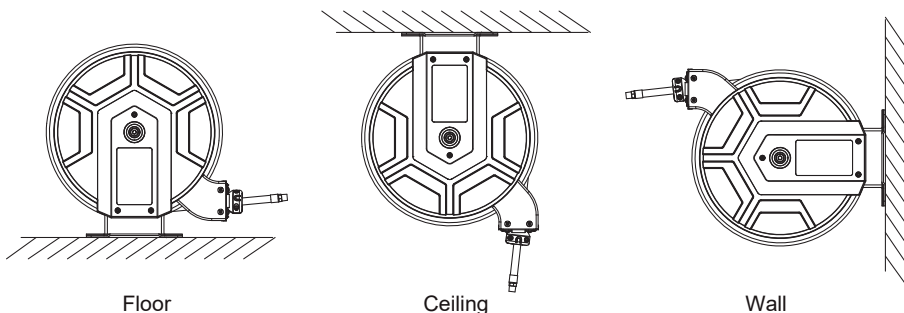

## OPERATION INSTRUCTIONS

1. When you want to use the hose, pull out the hose slowly to the desired length and release it. The hose may be retracted by a small section (about 10-15m) and get into a locked status for use.
2. When you want to retract the hose, pull the hose out about 4cm (1.6in) and release it. The hose can be retracted to the hose reel.
3. There is a slow retraction device installed on the hose reel. When the hose is in the retraction state, the slow retraction device will have a deceleration effect, which can significantly reduce the retraction speed of the hose (the longer the length of the retracted hose, the more obvious the deceleration effect), and ensure the operation safety of the hose when it is retracted.
4. Periodically check the hose condition for wear or damage, and check the swivel fitting for leakage. Replace any worn, damaged, or leaking parts.

### Hose Replacement

1. Turn off air supply to reel and carefully release pressure in hose.
2. Securely stabilize the reel by mounting or clamping to work surface.
3. Pull out all the old hose and lock the reel in this position.

**Caution: Make sure reel drum is securely locked by letting ratchet teeth engage.**

### Replacement of Hose (continued)

4. Remove the two hose clamps connecting the hose to the reel.
5. Carefully disconnect hose from the swivel joint on the side of the reel and discard old hose.
6. Feed new hose through guide and opening in drum, use sealant and connect to swivel. Reuse hose clamps on inside and outside of drum flange to reconnect hose.
7. Securely install stopper on other end of hose in the same position as before. Adjustments can be made later.



#### **WARNING:**

**Notice direction of the red arrow label on.**

8. Carefully release the drum latch, and while securely holding hose, slowly allow the hose to wind onto the reel.

**NOTE:** Final spring adjustment is accomplished by adding or removing wraps of hose around the drum. (Refer to Spring Tension Adjustment).



#### **WARNING:**

**The rewind spring is not serviceable. Do not remove spring cover.**

## SPRING CANISTER WARNING

If the rewind spring fails for any reason: For safety reasons, the manufacturer strongly recommends the replacement of the spring canister be carried out by a professional mechanic.

## LIMITED WARRANTY

1. Macnaught warrants this hose reel against defects in material and craftsmanship, for a period of 3 years from date of purchase.
2. Hose, if supplied with reel, O-rings, plastic rollers and rubber stopper are deemed to be normal wear items; not warranted.
3. Macnaught's liability is limited to replacement or repair of defective material within the warranty period, when returned freight prepaid to the distributor or their designated service depot.
4. The warranty does not cover damage caused by accident, misuse or faulty installation.
5. The reel must be installed and maintained in compliance with the instructions.

## STRUCTURE FEATURES

1. The five uniformly distributed locking points in this series of hose reel, ensure that the hose can be locked at any position after being pulled out. The diagram of the locking structure is as follows:

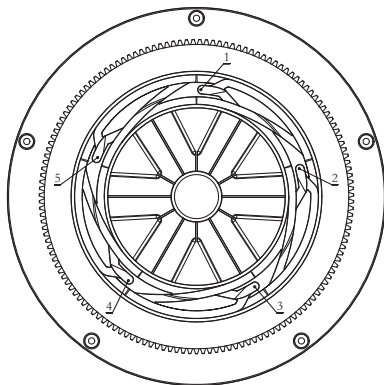

2. This series of hose reels are equipped with safety slow retraction device. Compared with the reels without this function, the speed of hose retraction can be significantly reduced and the operation safety can be improved. The working status of the slow retraction device is as follows:

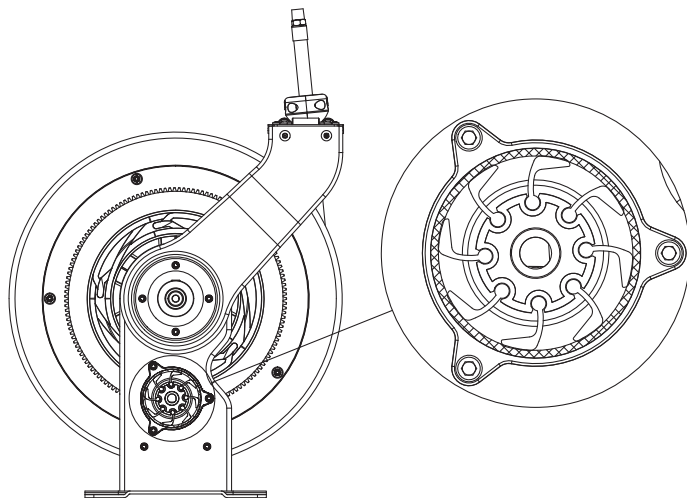

# EXPLODED AND PARTS LIST

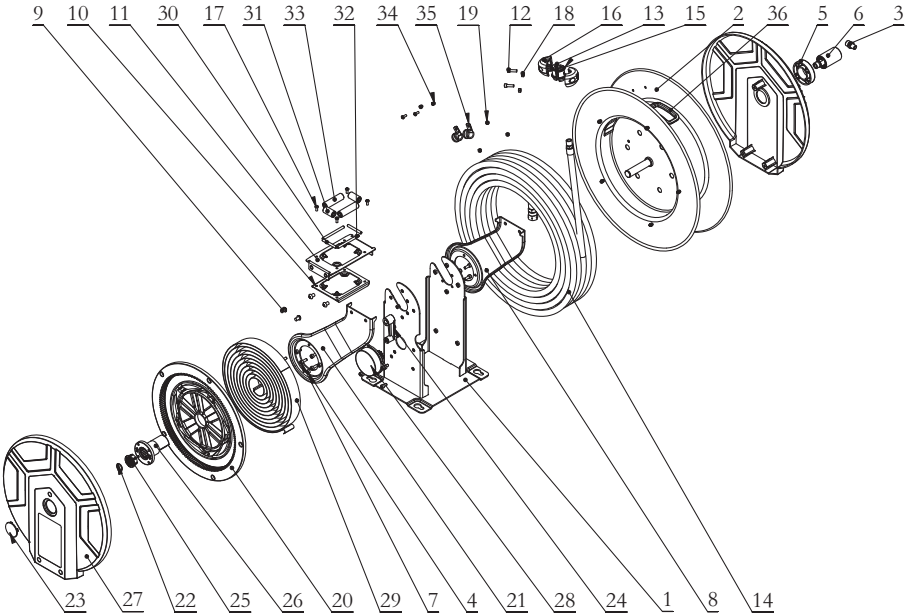

Part No.	Description	Q'ty	Part No.	Description	Q'ty
1	Base Assembly	1	19	Nut	9
2	Drum Assembly	1	20	Girth gear	1
3	Switch connector	1	21	Support plate	1
4	Screw	10	22	Elastic ring	1
5	Axle sleeve	1	23	End cover	1
6	Valve Assembly	1	24	Limiting device	1
7	Screw	11	25	Support arm sleeve	1
8	Guide arm parts	1	26	Spring core	1
9	Screw	4	27	Side cover	2
10	Roller base	1	28	Slow retraction device	1
11	Roller guide bracket	1	29	Spiral spring	1
12	Screw	2	30	Roller Axle	2
13	Stopper core	1	31	Roller	2
14	Hose Assembly	1	32	Roller Axle	2
15	Stopper core	1	33	Roller	2
16	Stopper	2	34	Nut	2
17	Screw	6	35	Hose Clamp	2
18	Nut	2	36	Trim strip	1

TECHNICAL  
DETAILS

SAFETY  
PRECAUTIONS

INSTALLATION  
INSTRUCTIONS

OPERATION  
INSTRUCTIONS

LIMITED  
WARRANTY

STRUCTURE  
FEATURES

EXPLODED AND  
PARTS LIST



**Macnaught Americas**  
**(813) 628-5506 | [info@macnaughtusa.com](mailto:info@macnaughtusa.com)**

\* Read Manual Before Use!