

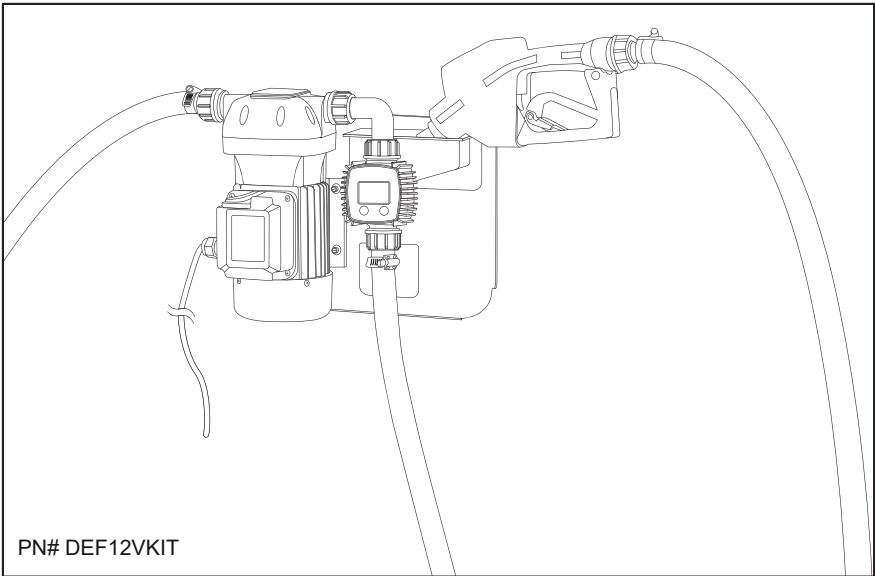

12V DEF Pump Kit Instruction Manual



WARNING:

Read carefully and understand all INSTRUCTIONS before operating. Failure to follow the safety rules and other basic safety precautions may result in serious personal injury. Save these instructions in a safe place and on hand so that they can be read when required. Keep these instructions to assist in future servicing.



GENERAL SAFETY REGULATIONS



WARNING: The warnings, cautions, and instructions discussed in this instruction manual cannot cover all possible conditions or situations that could occur. It must be understood by the operator that common sense and caution are factors that cannot be built into this product, but must be supplied by the operator.

1. Keep the work area clean and dry. Damp or wet work areas can result in injury.
2. Keep children away from work area. Do not allow children to handle this product.
3. Use the right tool for the job. Do not attempt to force small equipment to do the work of larger industrial equipment. There are certain applications for which this equipment was designed. It will do the job better and more safely at the capacity for which it was intended. Do not modify this equipment, and do not use this equipment for a purpose for which it was not intended.
4. Check for damaged parts. Before using this product, carefully check that it will operate properly and perform its intended function. Check for damaged parts and any other conditions that may affect the operation of this product. Replace damaged or worn parts immediately.
5. Do not overreach. Keep proper footing and balance at all times to prevent tripping, falling, back injury, etc.
6. DO NOT use the equipment when tired or under the influence of drugs, alcohol, or medication. A moment of inattention while operating this equipment may result in serious personal injury.

TECHNICAL DETAILS

Item No.		DEF12VKIT
Product Description		12V DEF PUMP KIT
Including	Pump	17550250 (Flow Rate 25LPM/6.6GPM)
	Suction Hose	5FT
	Delivery Hose	20FT
	Digital Meter	15221005
	Auto Nozzle	18311009
Mounting Bracket		

PUMP: Self-priming, volumetric, diaphragm pump, equipped with by-pass valve.

MOTOR: Asynchronous motor, single-phase, 2 pole, closed type (protection class IP55 in conformance with EN 60034-5-86 regulations) self-ventilated.

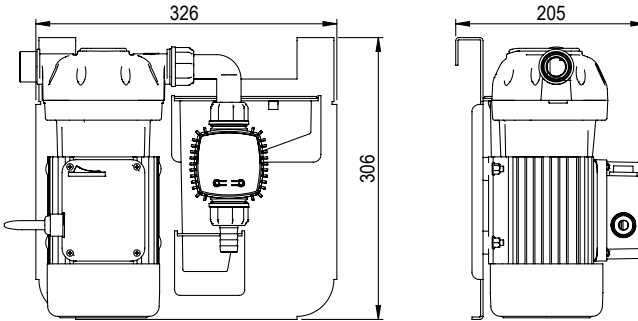

OPERATING

ENVIRONMENTAL CONDITIONS

- Temperature: Min. -10°C (14°F) / Max. +60°C(140°F)
- Relative Humidity: Max. 90%



ATTENTION! The temperature limits shown apply to the pump components and must be respected to avoid possible damage or malfunction.

ELECTRICAL POWER SUPPLY

- Depending on the model, the pump must be supplied by a single-phase alternating current line whose nominal values are shown in the table in Paragraph B1 – ELECTRICAL SPECIFICATIONS.
- The maximum acceptable variations from the electrical parameters are:
- Voltage: +/-5% of the nominal value
- Frequency: +/-2% of the nominal value



ATTENTION! Power from lines with values outside the indicated limits can damage the electrical components.

WORKING CYCLE

The pumps are designed for continuous use under maximum back pressure.



ATTENTION! Functioning under by-pass conditions is only allowed for brief periods of time (2-3minutes maximum).

FLUIDS PERMITTED

PERMITTED

- Chemical products: Urea, weak acid & weak alkaline fluid etc.
- Water

MOVING AND TRANSPORT

- Given the limited weight and size of the pumps (see overall dimensions), moving the pumps does not require the use of lifting devices.
- The pumps were carefully packed before shipment. Check the packing material on delivery and store in the dry place.

INSTALLATION

DISPOSING OF THE PACKING MATERIAL

- The packing material does not require special precautions, not being in any way dangerous or polluting.
- Refer to local regulations for its disposal.

PRELIMINARY INSPECTION

- Check that the machine has not suffered any damage during transport or storage.
- Clean the inlet and outlet openings, removing any dust or residual packing material.
- Make sure that the motor shaft turns freely.
- Check that the electrical specifications correspond to those shown on the identification plate.



ATTENTION! THE MOTORS ARE NOT OF AN ANTI-EXPLOSIVE TYPE. Do not install them where inflammable vapours can be present.

CONNECTING

- Before connection, make sure that the tubing and the suction tank are free of dirt and thread residue that could damage the pump and its accessories.
- Do not use conical threaded joints that could damage the threaded pump openings if excessively tightened.

Step 1: SUCTION HOSE:

Connect the 1.5M Suction hose by the Hose tail (#8) and Clamp (#12) to the inlet of the pump.

Step 2: DELIVERY HOSE:

Connect the 6M Delivery hose by the Hose tail (#8) and Clamp (#12) to the outlet of the pump or the flow meter.

Step 3: FLOW METER (Optional):

Connect the flow meter by the Elbow (#9) to the outlet of the pump.

Step 4: NOZZLE:

Connect the dispensing nozzle by the Clamp (#12) to the delivery hose.

E4. DISPENSING:

After installation the completed pump system as picture indicated, connect the power supply, start dispensing.



ATTENTION! It is the installer's responsibility to use tubing with adequate characteristics. Loosening of the connections (threaded connections, flanging, gasket seals) can cause serious ecological and safety problem. Check all the connections after the initial installation and on a daily basis after that. Tighten the connections, if necessary.

DAILY USE

- If using flexible tubing, attach the ends of the tubing to the tanks. In the absence of an appropriate slot, solidly grasp the delivery tube before beginning dispensing.
- Before starting the pump, make sure that the delivery valve is closed (dispensing nozzle or line valve).
- Turn the ON/OFF switch to ON. The by-pass valve allows functioning with the delivery closed only for brief periods.
- Open the delivery valve, solidly grasping the end of the tubing.
- Close the delivery valve to stop dispensing.
- When dispensing is finished, turn off the pump.



ATTENTION! Function with the delivery closed is only allowed for brief periods (2-3 minutes maximum). After using, make sure the pump is turned off.

TURBINE DIGITAL METER

1: Technical Data

1. The liquids compatible with turbine digital meter must be at low viscosity, namely:

- Diesel fuel
- Water
- Water/urea solution
- Kerosene
- Windscreen cleaner

Use of other fluids may be inaccurate and can damage the meter

2. Flow Rate: 10-100LPM/3-26GPM, flow rates outside of this range may be off.
3. Operating pressure: 10BAR/145PSI
4. Inlet/Outlet: 1"

Not suitable when used in a retail sale of diesel, oil or kerosene!

2: LCD DISPLAY

The "LCD" of the meter features two numerical Registers and various indications displayed to the user only when the applicable function so requires

KEY

① Partial register (5 figures with moving comma from 0.1 to 99999)

Indicating the volume dispensed since the reset button was last pressed.

② Indication of battery charge

③ Indication of calibration mode

④ Indication of resetting present total to Zero

⑤ Total register

⑥ Indication of flow rate mode

⑦ Indication of unit of measurement of partial:

L = Litres

GAL = Gallons

PT = Pints

QT = Quarts

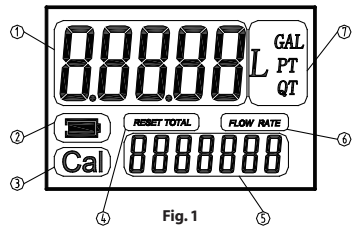

3: USER BUTTONS

The turbine digital meter features two buttons (MENU and RESET) which individually perform two main functions and together, other secondary functions.

The main functions performed are:

For the reset key, resetting the partial Register and reset table total (reset total)

For the menu key, entering instrument calibration mode.

Used together, the two keys permit entering configuration mode.

4: BATTERY REPLACEMENT

When replacing the battery, please open the cover, remove the plug and replace the battery.

INSTALLATION

The inlet and outlet for this meter is 1"BSP/NPT. It can be easily connected with the pipe or nozzle.

DAILY USE

1: BUTTON USAGE, CALIBRATION AND MEASUREMENT UNIT CHANGE

• Reset the present total (See Fig. 2)

- 1) When the meter is on standby, press the RESET key.
- 2) The display shows all the segments.
- 3) The meter resets the present total already.

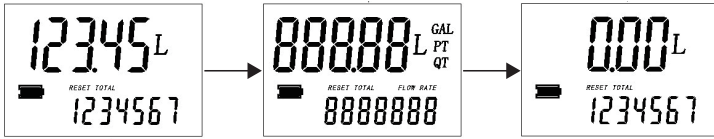

Fig. 2

• Show current correction factor and general total (See Fig. 3)

Press MENU and RESET together and hold for two seconds. Value "1.4000" is the correction factor which can be reset; "1234567" is the general total which cannot be reset



Fig. 3

• Measurement unit change (See Fig. 4)

Press MENU and RESET together and hold for five seconds. Zone 7 on the display is the current unit. Press RESET to chose a different measurement unit and then press MENU to confirm.

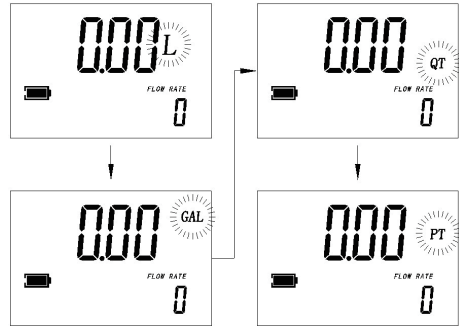

Fig. 4

2: RESET THE RESETTABLE TOTAL (See Fig. 5)

When the meter is on standby, press the RESET key for 2 seconds to reset the present total first.

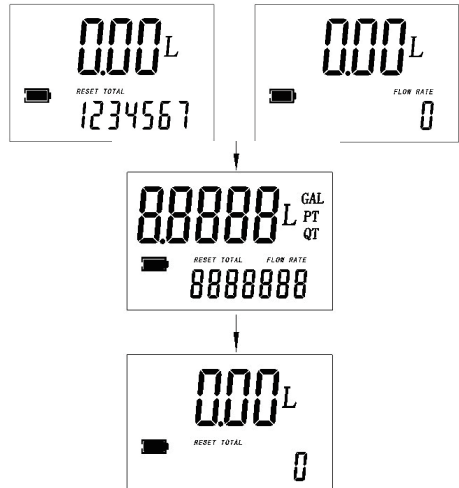

Fig. 5

3: PROCEDURE FOR ENTER THE CORRECTION FACTOR DIRECTLY

Carefully follow the procedure indicated below.

FORMULA

Proper correction factor = current correction factor × (actual value / display value)



Example:

Actual value 20.75

Display value 18.96



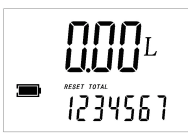
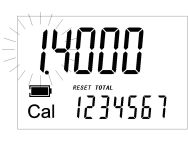

Current correction factor 1.000

Proper correction factor $1.000 \times (20.75 / 18.96) = 1.000 \times 1.094 = 1.094$

1	Wait for the meter to go to standby.	
2	Reset the resettable total.	
3	Press the MENU key. Keep it pressed until similar with the image showed (the digit flash in ① zone), it means the meter is in correction factor modification mode.	
4	Press the RESET key to choose the right digit from 0 to 9. Press the MENU key to start the next digit. So the digit of correction factor can be changed one by one.	
5	Make sure the correction factor is right, press the MENU key. Keep it pressed until quit calibration mode, the factor is saved. The meter goes to standby again.	

4: MODIFY THE CORRECTION FACTOR IN FIELD

PLEASE CAREFULLY FOLLOW THE PROCEDURE INDICATED BELOW.

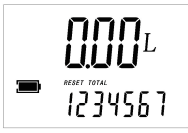
1	Wait for the meter to go to standby.	
2	Reset the resettable total.	
3	Start dispensing into a measuring glass. Stop dispensing when over 5 Litres of volume is reached, read out the actual value. The volume that is displayed on the LCD is the Display Value, not the Actual Value which may be slightly higher. For example, in the figure on the right, the Display Value is 18.96 while the Actual Value is 20.75.	
4	Press the MENU key. Keep it pressed until showed as the right fig., the digit flash in ① zone, Press the RESET key to choose the right digit from 0 to 9. Press the MENU key to go the the next digit so that the Actual Value can be input.	 
5	Make sure the correction factor is right and then press the MENU key. Keep it pressed until calibration is finished and the factor is save. The meter will then return to standby.	

MALFUNCTIONS

Problem	Possible Cause	Corrective Action
LCD: no indication.	Bad battery contact.	Check battery contacts.
Imprecise measurement.	Wrong FACTOR.	With reference to paragraph 3.3 & 3.4, check the FACTOR.
Reduced or zero flow rate.	The meter works below minimum acceptable flow rate.	Increase the flow rate until an acceptable flow rate range has been achieved.
The meter does	Turbine blocked.	Clean the turbine.
not count, but the flow rate is correct.	Incorrect installation of turbine after cleaning.	Repeat the reassembly process.
	Possible electronic card problems.	Contact the dealers or manufactures.

MAINTENANCE

All models are designed and constructed to require a minimum of maintenance.

In any case always bear in mind the following basic recommendations for a good functioning of the pump:

- On a weekly basis, check that the tubing joints have not loosened, to avoid any leakage.
- On a monthly basis, check the pump body and keep it clean of any impurities.
- On a weekly basis, check and keep clean the line suction filter.
- On a monthly basis, check that the electric power supply cables are in good condition.

NOISE LEVEL

- Under normal working conditions the noise emission from all models does not exceed the value of 80 db at a distance of 1 meter from the electric pump.

DISPOSING OF CONTAMINATED MATERIALS

- In the event of maintenance or demolition of the machine, do not disperse contaminated parts into the environment.
- Refer to local regulations for their proper disposal.

PROBLEMS AND SOLUTIONS

Problem	Possible Cause	Corrective Action
The Motor is not turning	Lack of electric power	Check the electrical connecting
	Motor Problems	Contact the Service Department
The motor turns slowly when starting	Low voltage in the electric power line	Bring the voltage back within the anticipated limits
Low or not flow rate	Low level in the suction tank	Refill the tank
	Filter clogged	Clean the filter
	Excessive suction pressure	Lower the pump with respect to the level of the tank or increase the cross-section of the tubing
	High loss of head in the delivery circuit (working with the by-pass open)	Use shorter tubing or of greater diameter
	By-pass valve blocked	Dismantle the valve, clean and/or replace it.
	Air entering the pump or the suction tubing	Check the seals of the Connections
	A narrowing in the suction tubing	Use tubing suitable for working under suction pressure
	Low rotation speed	Check the voltage at the pump. Adjust the voltage and/or use cables of greater crosssection
Increased pump noise	The suction tubing is resting on the bottom of the tank	Raise the tubing
	Cavitation occurring	Reduce suction pressure
Leakage from the pump body	Irregular functioning of the by-pass	Dispense fluid until the air is purged from the by-pass system
	Diaphragm damaged	Check and replace the diaphragm

EXPLODED AND PARTS LIST

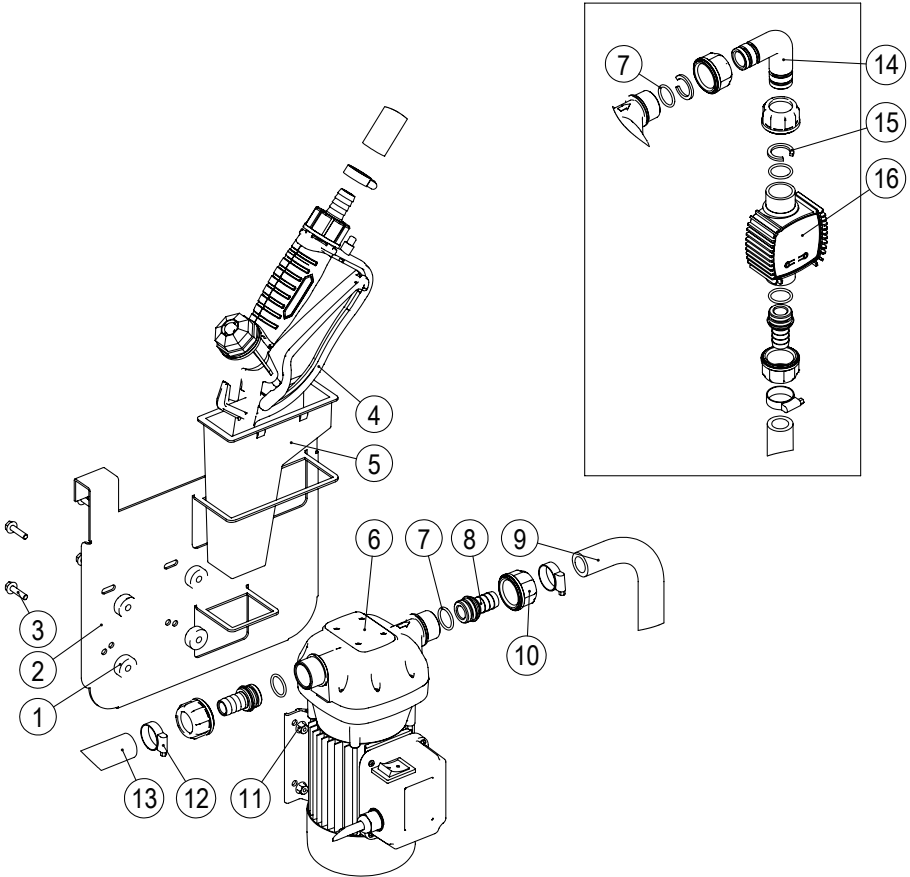

Part No.	Description	Q'ty	Part No.	Description	Q'ty
1	Crash gasket	4	9	Delivery hose	6.5m
2	Bracket	1	10	Nut	2(4)
3	Bolt	4	11	Nut	4
4	Nozzle	1	12	Hose clamp	3
5	Nozzle holder	1	13	Suction hose	1.5m
6	Electric pump	1	14	Elbow	1
7	O-ring	2(4)	15	Circlip	2
8	Hose tail	3	16	Flow meter	1



Macnaught Americas
(813) 628-5506 | info@macnaughtusa.com

* Read Manual Before Use!