

Hiny Hiders®

Toilet Compartments

Installation Instructions



**HINY
HIDERS®**

BY SCRANTON PRODUCTS

Thank you for purchasing Scranton Products Hiny Hiders® Partitions. If you have questions, comments or issues with the product you received, please contact us:



SCRANTON
PRODUCTS®

801 East Corey Street
Scranton, PA 18505
800.445.5148 (toll free)
800.551.6993 (fax)
info@scrantonproducts.com
www.scrantonproducts.com

- Please review these instructions completely prior to installation.
- Visit www.scrantonproducts.com/eclipseinstallation/ to ensure you are viewing the most current installation instructions, care and maintenance, technical information and more.
- Failure to install Hiny Hiders toilet compartments in accordance with applicable building codes and this Installation Guide may lead to personal injury, effect partition system performance and void the product warranty.

Please note, some hardware is not covered in this booklet. Any hardware not in this booklet will have its own separate installation instructions included with it, do not disregard these you will need them to install.

Section 1	Site Preparation	3
Section 2	Fasteners	4
Section 3	Understanding Your Drawings	5
Section 4	General Layout Info./Mounting Types	6
Section 5	Brackets	11
Section 6	Headrail	15
Section 7	Crossbracing for Ceiling Hung	17
Section 8	76" Stiffener	18
Section 9	Stacked Panel	19
Section 10	Hinges	20
Section 11	Coat Hook & Bumpers	28
Section 12	Vanity	29
Section 13	Locker Bench	32
Section 14	Terrazzo Base / Shower Cube	33
	Care & Maintenance	34

Section 1: Site Preparation

Pre-Check

Check the materials completely as soon as possible. Check against the pick ticket and layout drawings. If you are missing parts or have received damaged product, contact your dealer.

Material Storage & Handling

- Lay material flat, do not store against a wall or stack unevenly. This will prevent the material from warping.
- Leave protective masking on until installation is complete to prevent scratches.
- Protect from exposure to direct sunlight. Product is not intended for outdoor use.
- Use care when handling the product with a forklift. Forks can easily damage the material.
- If banding is used, use protective corners to prevent indents from the bands.
- Extreme heat warning: extreme elevation of surface temperature, which exceeds that of normal exposure, can possibly cause the product to melt, sag, warp, discolor, and increase expansion/contraction.
- Excessive construction debris: it is important during construction that the product surfaces stay clear from excessive build-up of dirt, sand, and dust from tile, concrete, or other masonry products.
- Do not use Hiny Hiders® Partitions toilet compartments as a work surface.
- If build-up does occur, please refer to the Care and Maintenance section of this installation guide for proper cleaning instructions.

Tools Needed

<ul style="list-style-type: none">- Chalk Line- Tape Measure- Screwdrivers (Phillips & Flat head)- Adjustable Wrench- Level- Jigsaw (or Hacksaw)	<ul style="list-style-type: none">- Power Drill with/<ul style="list-style-type: none">- 5/16" Masonry bit- 3/32", 5/32", & 1/4" Metal bits.- T27 torx bit (supplied by Scranton Products)- 14" x 14" spacer block to rest doors and panels on for easier installation.- Factory provided drawings
---	--

Section 2: Fasteners

1 1/2" STAINLESS STEEL #14 TORX HEAD SCREW

ITEM # - HF15THS

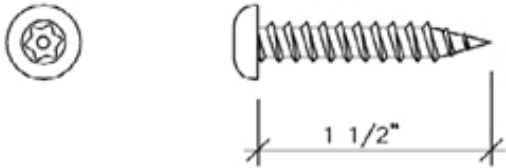

5/16" LAGBOLT

ITEM # - HFLAGS

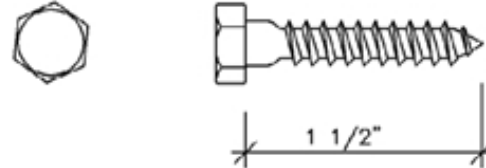

2 1/2" STAINLESS STEEL #14 TORX HEAD SCREW

ITEM # - HF25THS

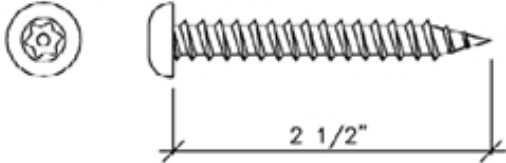

1 3/4" ZINC PLATED STEEL #14 SCREW

ITEM # - HF175THS

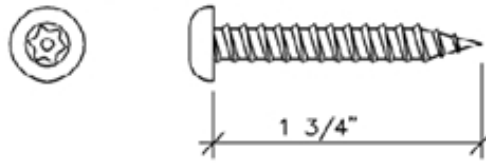

PLASTIC ANCHOR

ITEM # - HFPA

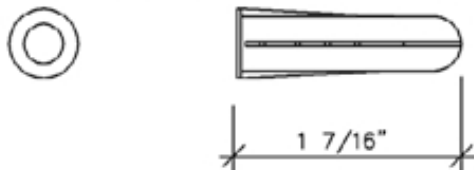

2" STAINLESS STEEL #20 PHILLIPS HEAD MACHINE SCREW

ITEM # - HF2PHFS

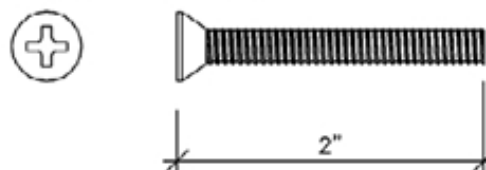

3/4" STAINLESS STEEL TORX HEAD #14 SCREW

ITEM # - HF75THS



2" STAINLESS STEEL #20 PHILLIPS HEAD MACHINE SCREW

ITEM # - HF2PHRS

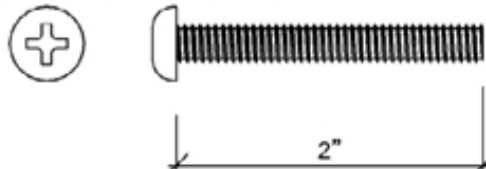

10/24 X 1.11" LENGTH, TORX HEAD THRU-BOLT.

ITEM # - HF718SBF (FEMALE)



1 5/16" X 1/2" dia. LEAD EXPANSION SHIELD

ITEM # - HFESL

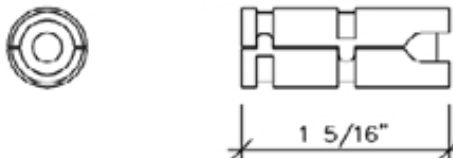

10/24 X .85" LENGTH, TORX HEAD THRU-BOLT.

ITEM # - HF843SBM (MALE)

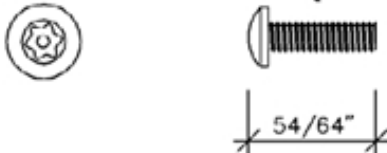

1 1/2" STAINLESS STEEL ONE-WAY #10 MALE MACHINE BOLT

ITEM # - HF15MBS

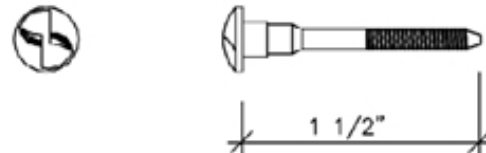

5/8" STAINLESS STEEL #10 ONE-WAY SCREW.

ITEM # - HF625OWS



1" STAINLESS STEEL #8 HINGE SCREW

ITEM # - HF1HSS

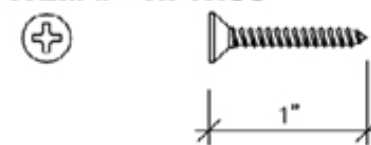

Section 3: Understanding Your Shop Drawings

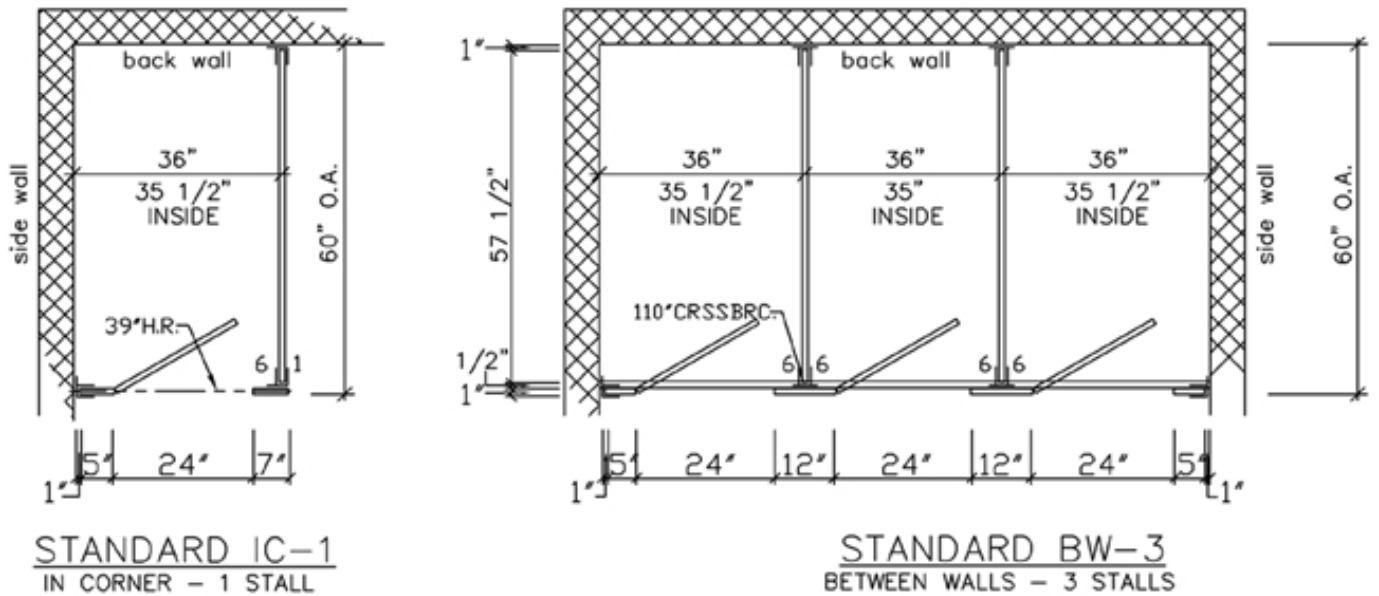

Reading Shop Drawing Abbreviations

60" O.A. stands for the overall dimension from the back wall to the front face of the pilasters. When the overall is shown as 60" your panel will be 57 1/2" long. To achieve your 60" overall you will set the gap at the back wall to 1" and the gap at the pilaster to panel connection to 1/2" add in the 1" thick pilaster you get 60" overall.

39" H.R. as shown on the IC-1 stall stands for head rail. This is supplied for our floor mounted over head braced system only. All of the head rail will be oversized by the factory 2" to allow for any variance that may occur in the field. The installer must field trim to proper size.

110" CRSSBRC as shown on the BW-3 shall stands for Cross brace. This is supplied for our ceiling hung system only. All of the cross brace will be oversized by the factory 2" to allow for any variance that may occur in the field. The installer must field trim to proper size.

Understanding Shop Drawing Dimensions

Stall Widths When shown in an application with one wall and one panel the 36" dimension is from the face of the wall to the center of the 1" thick panel, thus giving you 35 1/2" on the inside of the stall. When used between two panels the 36" dim is from the center line of panel to center line of panel which would leave you 35" inside the stall.

Pilaster Splits When a pilaster split is shown it is the distance the panel is spaced on the pilaster from side to side. When shown as a 6/6 split on a 12" pilaster the panel will be dead center on the pilaster. Because it is 6" to center of the 1" thick panel from the edge of the pilaster you will have only 5 1/2" of the pilaster showing on the inside of the stalls.

Section 4: General Layout Information

Step 1. Center Line Dimensions

To locate the centerline of the pilasters, measure from the back wall out to the overall dimension of the stall depth on your shop drawings (in EXP. A 60") then subtract 1/2" (in EXP. A 59 1/2" C/L.). Draw a line at this mark parallel to the back wall and a mark up the side wall 70", this will give you the center line of your shoes & bracket connections.

Step 2. Side Wall Brackets

At the 70" line you will have now drawn up the side wall(s), measure from the floor up 14 1/2" for continuous brackets (14 1/2" is to the bottom of the bracket), or if you are using stirrup brackets measure up from the floor 17" for the first bracket, 42" for the second bracket, and 66" for the third bracket, these are for the center of the brackets, not the bottoms. Once you have your locations, hold the brackets to the wall and mark the spots of the pre-drilled holes on the brackets to the wall. Drill a 5/16" hole and insert a plastic anchor at all of the marks, replace the bracket and secure it to the wall with the 1 1/2" torx head screws. (See EXP. B next page)

Step 3. Back Wall Brackets

Using your shop drawings get the stall width dimensions and measure across the back wall to get the center lines of your brackets (in EXP. A it would be 36"). Measure up the wall your 70" line and mark your bracket locations and mount them.

Please Note: An optional metal strip may be attached to the edge of the panels and doors. This must be installed on the bottom.

Note: All dimensions are for illustration purposes only. See your drawings for actual dimensions.

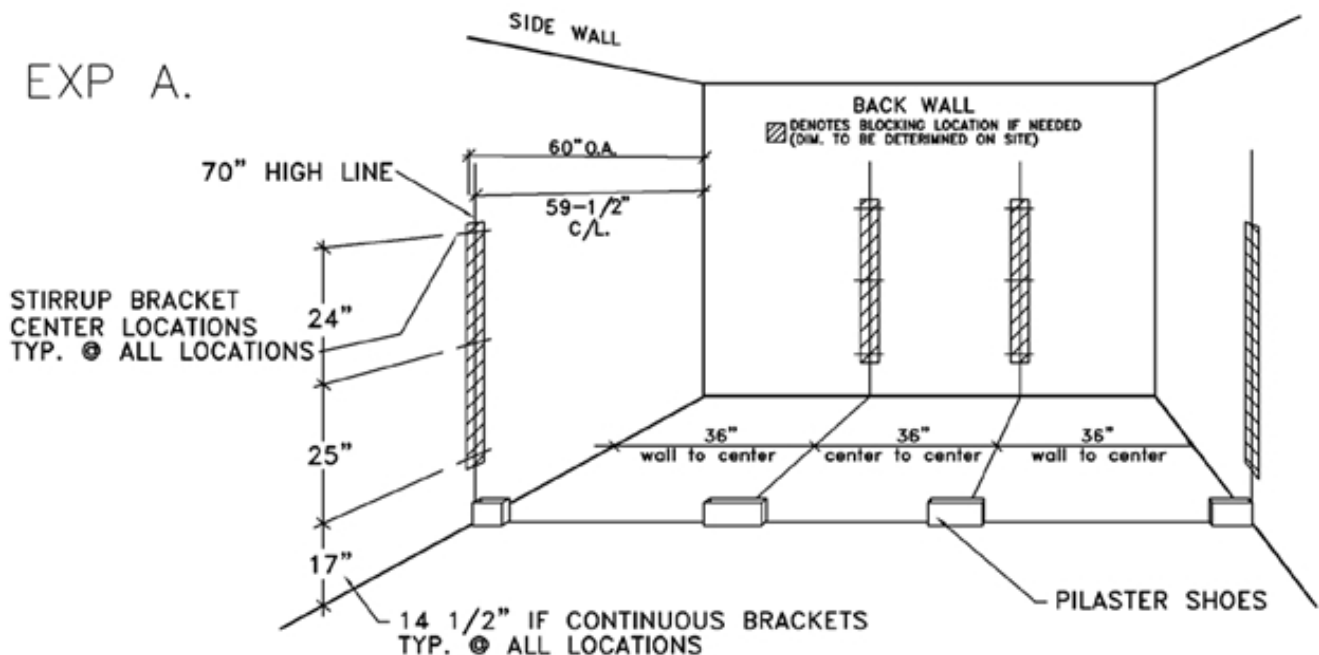

Section 4: Pilaster to Floor Attachment

Locate the centerline of the front pilasters. Measure from the back wall to the front of the pilasters. This dimension is the "Over All" dimension, noted on the shop drawings as (O.A.). Subtract 1/2" from this dimension and draw a line on the floor parallel from the back wall.

Leaving the indicated space (per the drawings) between the wall and the edge of the pilaster. Hold the pilaster in place as noted on the drawings and mark the floor around the bottom of the pilaster. This mark will indicate the location of the first shoe. Set shoe on mark and mark the shoe hole locations. Remove shoe. Drill 5/16" holes and insert the plastic anchors. Replace the shoe and secure with the (1/4" washer if needed) 1 1/2" torx screws. Continue to follow the drawings for the location of the remaining shoes.

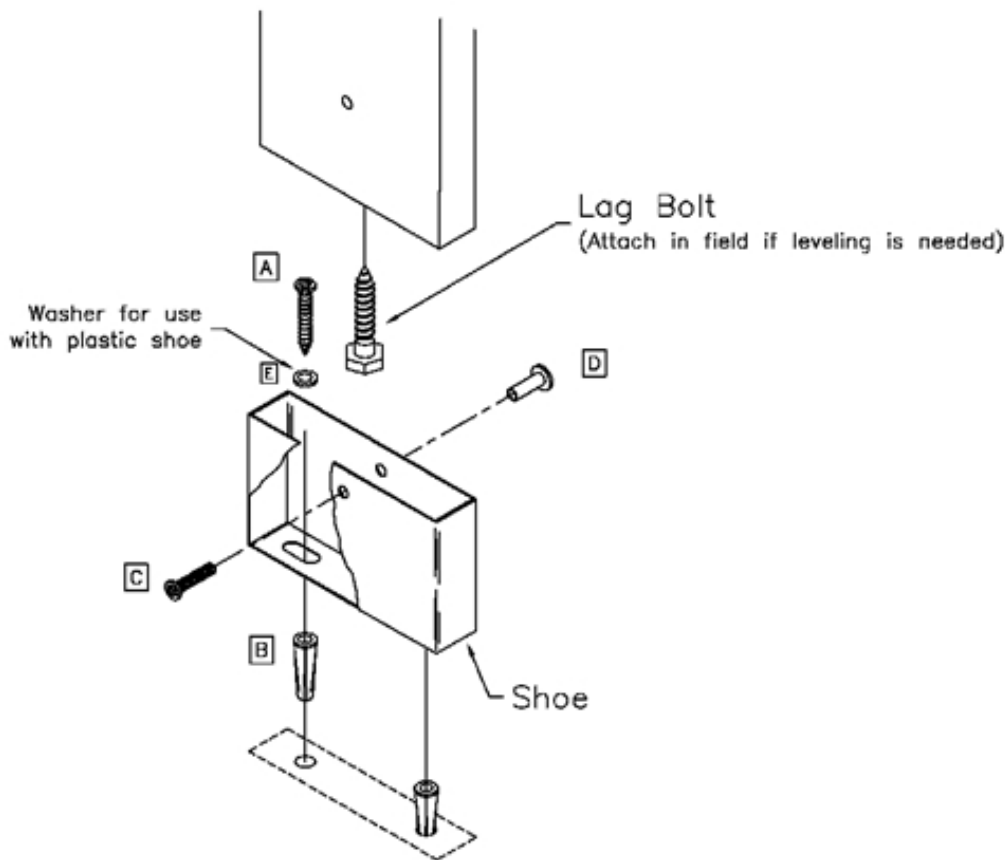

Fasteners (3" to 24")

Qty	Item #	Description
2	A HF15THS	1 1/2" Torx Head Screw
2	B HFPA	Plastic Anchor
1	C HF843SBM	10/24 x .830" Male Sex Bolt
1	D HF718SBF	10/24 x .830" Female Sex Bolt
2	E HF25FWS	1/4" Flat St/St Washer
*1	HF75THS	3/4" Torx Head Screw

*Fastener used for headrail. See headrail instructions.

Section 4: Floor & Ceiling Attachment for Floor to Ceiling

Locate the centerline of the front pilasters. Measure from the back wall to the front of the pilasters. This dimension is the "Over All" dimension, noted on the shop drawings as (O.A.). Subtract 1/2" from this dimension and draw a line on the floor/ceiling parallel from the back wall.

Hold the pilaster in place as noted on the drawings, and place the st/st angle behind the pilaster. (Note: 4" to 9" pilasters receive 1 angle which is centered on the pilaster, 10" to 24" pilasters receive two brackets which must be placed approximately 1" from the sides). Keeping the st/st angle in place remove the pilaster and fasten to the ceiling using the 1 1/2" screws. Now slide the sleeve onto the top of the pilaster with the lip of the sleeve on the bottom backside of the pilaster (do not fasten at this time). Drill two 1/4" holes into the angle. Drill a 5/32" pilot hole 1/2" into the pilaster and secure with 3/4" torx screw. Slide the sleeve back up to the ceiling and drill at 5/32" pilot hole 1/2" into the pilaster and secure with a 3/4" torx screw.

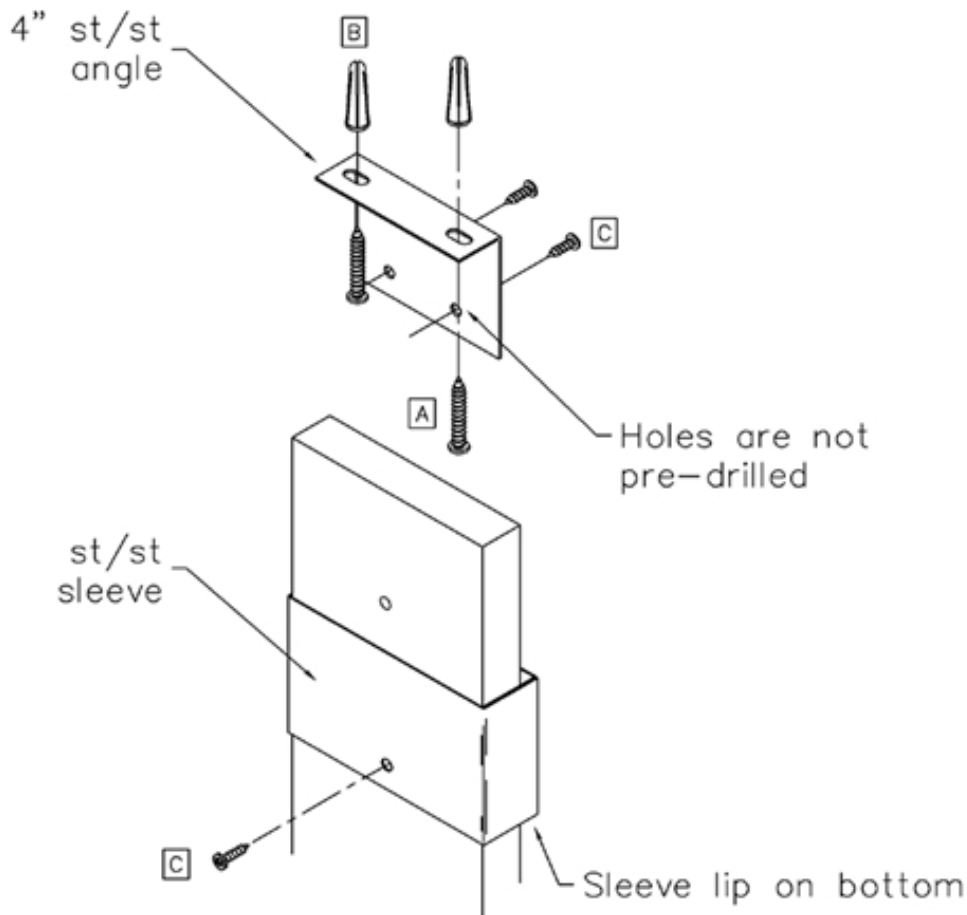

Fasteners (4" to 9")

Qty	Item #	Description
2	A HF15THS	1 1/2" Torx Head Screw
2	B HFPA	Plastic Anchor
3	C HF75THS	3/4" Torx Head Screw

Fasteners (10" to 24")

Qty	Item #	Description
4	A HF15THS	1 1/2" Torx Head Screw
4	B HFPA	Plastic Anchor
5	C HF75THS	3/4" Torx Head Screw

Section 4: Ceiling Attachment for Ceiling Hung

- When installing ceiling hung partitions keep in mind that everything must be tightened completely and correctly.
- Locate structural steel in the ceiling, (cannot be wood, masonry, or drop ceiling) this is what you will be attaching the pilasters to.

Install the Mounting Hardware to the Pilasters as Shown

1. The barstock is to be connected to the pilasters prior to mounting. To mount the barstock to the pilaster, use the 2 1/2" bolts and mounting dowels. Push the dowels into the holes drilled through the face of the pilaster. Using a flat head screwdriver, turn the dowel until the groove is pointing straight up and down. Make sure that the dowel is centered in the pilaster. Place the 2 1/2" bolts in through the top of the pilaster and tighten it down, fastening the barstock to the pilaster.
2. Mount the threaded rod into the structural steel in the ceiling. Attach the threaded rod to the structural steel using 5/8" nuts, 7/8" flat washer, lock washer. Place the rod so that it is below the finished ceiling by 2 1/4"-2 3/4". Tighten the connections at the steel and proceed. When tightening bolts, take care to make sure they are snug but, DO NOT OVERTIGHTEN.
3. Once the barstock is mounted to the pilaster, you are ready to attach the pilaster to the threaded rod. Raise the pilaster to the threaded rod. Attach the threaded rod to the barstock using the 5/8" nuts, 7/8" flat washer, and the lock washer. Do not completely tighten the hardware until you have made your final adjustments.
4. Once the pilaster is mounted, you can make your final adjustments. Make sure that the pilaster is level and plumb before tightening all of the nuts. You can adjust for level and plumb using the connections to the threaded rod and barstock.
5. Once all adjustments have been made you can slide the sleeve up to the finished ceiling. Fasten the sleeve using the sex-bolt provided.

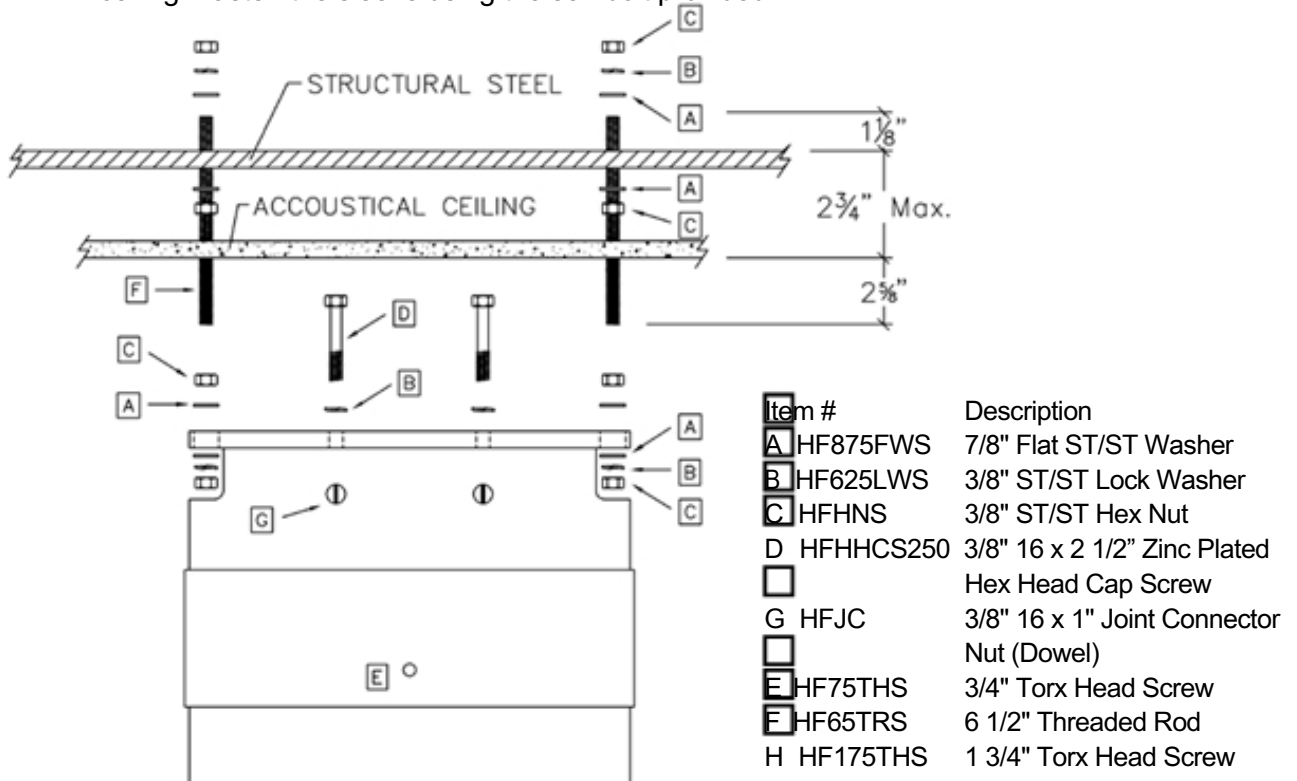

Scranton Products' ceiling hung partitions are installed using 6 1/2" threaded rod. The threaded rod is attached into the aluminum bar stock (see below). There are two slotted holes on either end of the bar stock. This is where the threaded rod attaches into the bar stock. This slotted hole is 1" wide to allow for adjustment. This is typical for all pilaster sizes (4"-to-24") available in ceiling hung.



Aluminum Bar Stock Detail

The holes for the threaded rod should be drilled for the center of the slotted holes in the bar stock. These holes should be drilled 5/8" in from the edge of the pilaster (bar stock).

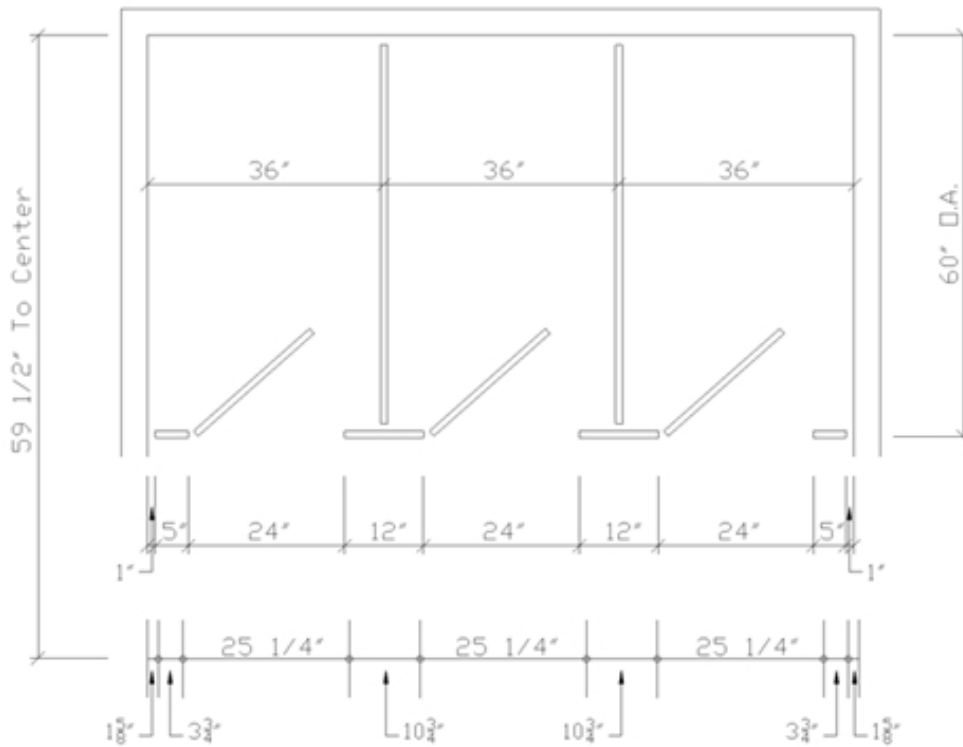

Sample Bolt Hole Layout*

Shown above is a "sample" layout, with bolt hole locations. Note that the "centerline" dimension for the depth of the stall will be 1/2" deducted from the "overall depth" of the stalls. The bolt holes are located 5/8" in from the edge of the pilaster.

*Attention: Before drilling the holes for the ceiling hardware, make sure that you have verified all dimensions, and that there will be no further changes. Pilasters & bar stock cannot be modified to fit.

Section 5: Stirrup Brackets

Step 4. Pilaster to Floor Connections

See "Pilaster to floor attachment" sheet that is supplied separately.

Note: if you are installing Floor to Ceiling mounted partitions also see the "Ceiling attachment for floor to ceiling" sheet at this time.

Step 5. Pilaster/Panel to Wall Connection

Set the first pilaster in the wall bracket and shoe that were installed in the previous steps. Making sure the pilaster is level and plumb (if not use the leveling bolt in the bottom of the pilaster), drill 1/4" holes through the pilaster using the pre-drilled holes in the brackets as a guide and secure using torx head sex bolts. (See EXP. B)

Please Note: An optional metal strip may be attached to the edge of the panels and doors. This must be installed on the bottom.

Set your first panel into position at the back-wall bracket. (Use the 14" high spacer block to stabilize the panel). Set the panel 1" from the back wall, making sure the panel is level and plumb drill 1/4" holes through the panel using the pre-drilled holes in the bracket as a guide, and secure the panel and bracket using the torx head sex bolts.

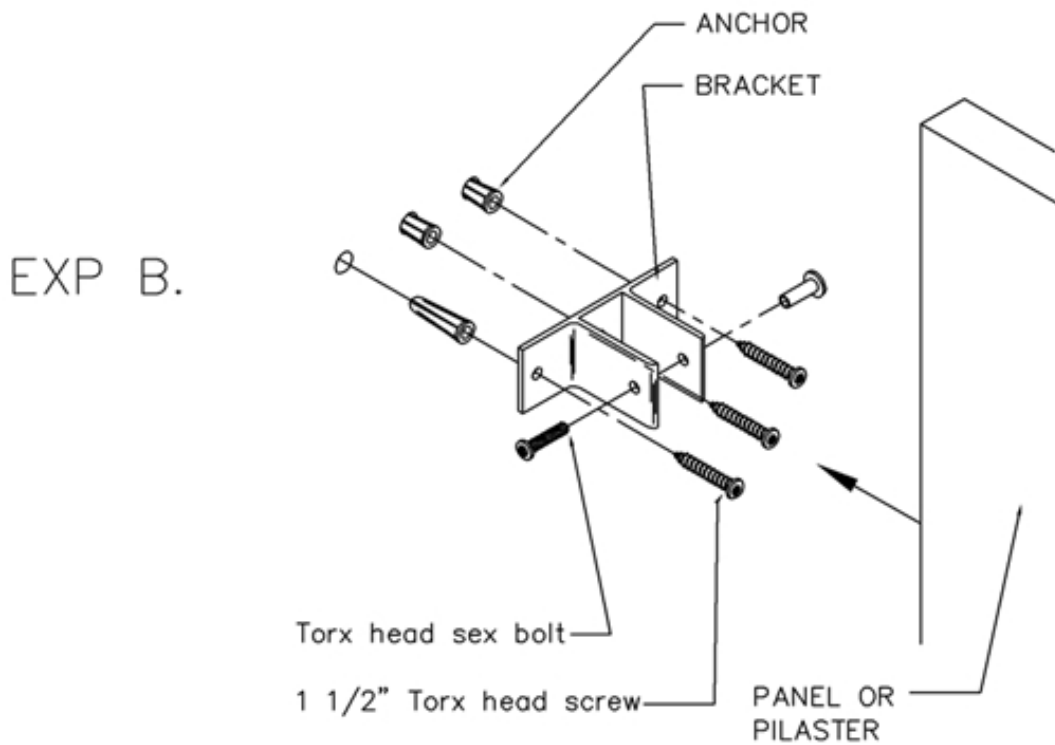

PANEL AND/OR PILASTER TO WALL ATTACHMENT
STIRRUP BRACKET SHOWN

Section 5: Stirrup Brackets

Step 6. Pilaster to Panel Connection

Please Note: An optional metal strip may be attached to the edge of the panels and doors. This must be installed on the bottom.

Take the second pilaster and lay it on a flat surface, measure from the side toward the middle of the pilaster using the pilaster split called out on your shop drawings (in EXP. C for the 12" pilaster the split is called out at 6/6 split this is typ. for this drawing only). Mark a line at this position, this is your pilaster center line, now place your bracket on the pilaster, center the bracket over the pilaster center line and fasten your bracket to the pilaster.

Place the pilaster with bracket in the second shoe and make sure it is level and plumb, checking the gap between the pilaster and the panel edge (1/2" gap STD). Drill 1/4" holes through the panel using the pre-drilled holes in the bracket as a guide and secure pilaster to panel with torx head sex bolts (with the panel mounted you should have 5 1/2" from the edge of the pilaster to the face of the panel).

Repeat these steps for the rest of your pilasters.

Clean Look: (If noted on shop drawings) To install the stirrup bracket using the "clean look" drill a 5/32" pilot hole 1/2" deep, secure with a 3/4" torx screw.

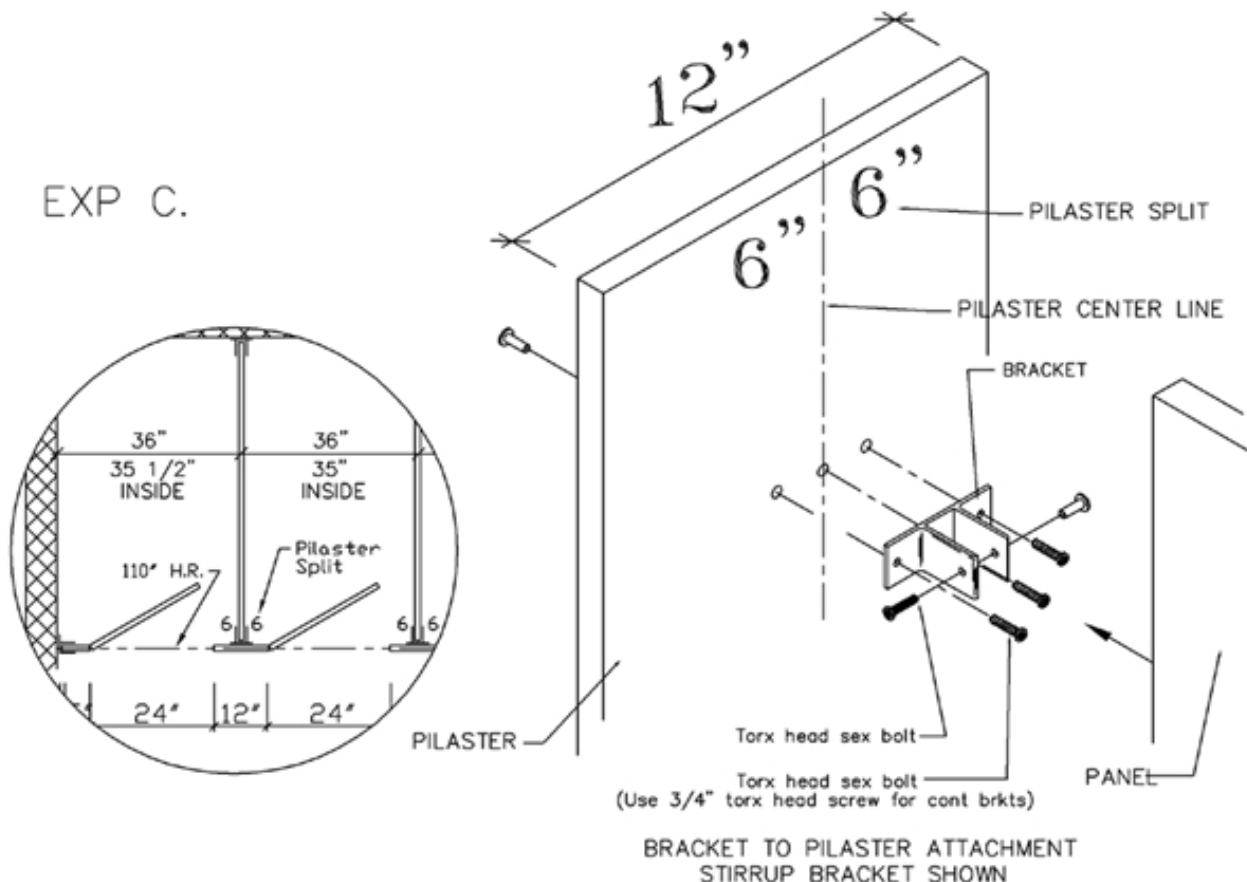

Section 5: Continuous Brackets

Step 4. Pilaster to Floor Connection

See "Pilaster to floor attachment" sheet that is supplied separately.

Note: If you are installing Floor to Ceiling mounted partitions also see the "Ceiling attachment for floor to ceiling" sheet at this time.

Step 5. Pilaster/Panel to Wall Connection

Set the first pilaster in the wall bracket and shoe that were installed in the previous steps. Making sure the pilaster is level and plumb (if not use the leveling bolt in the bottom of the pilaster), drill 1/4" holes through the pilaster using the pre-drilled holes in the brackets as a guide and secure using torx head sex bolts. (See EXP. B)

Please Note: An optional metal strip may be attached to the edge of the panels and doors. This must be installed on the bottom.

Set your first panel into position at the back wall bracket. (Use the 14" high spacer block to stabilize the panel). Set the panel 1" from the back wall, making sure the panel is level and plumb drill 1/4" holes through the panel using the pre-drilled holes in the bracket as a guide, and secure the panel and bracket using the torx head sex bolts.

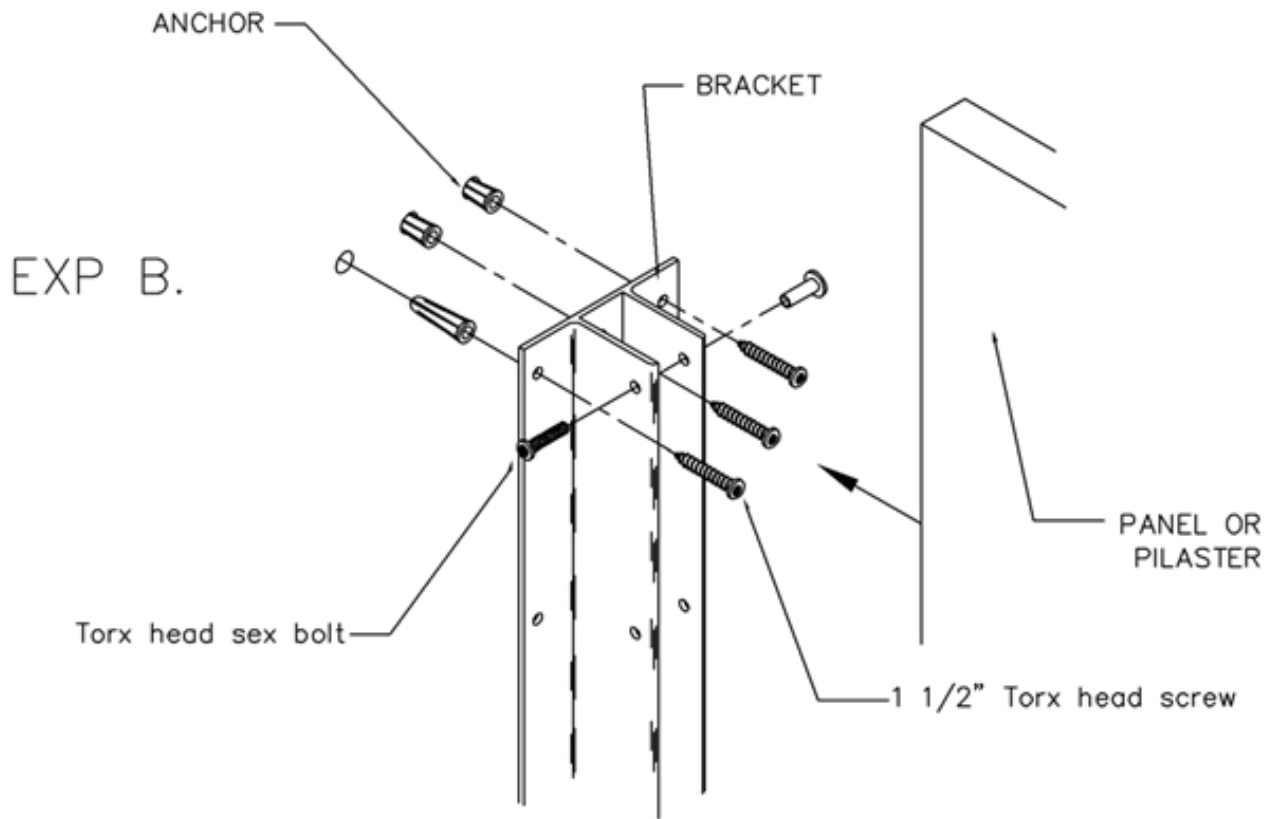

PANEL AND/OR PILASTER TO WALL ATTACHMENT
CONTINUOUS BRACKET SHOWN

Step 6. Pilaster to Panel Connection

Please Note: An optional metal strip may be attached to the edge of the panels and doors. This must be installed on the bottom.

Take the second pilaster and lay it on a flat surface, measure from the side toward the middle of the pilaster using the pilaster split called out on your shop drawings (in EXP. C for the 12" pilaster the split is called out at 6/6 split, this is typical for this drawing only). Mark a line at this position, this is your pilaster center line, now place your bracket on the pilaster, center the bracket over the pilaster center line and fasten your bracket to the pilaster. Drill a 5/32" pilot hole 1/2" deep, secure with a 3/4" torx screw.

Place the pilaster with bracket in the second shoe and make sure it is level and plumb, checking the gap between the pilaster and the panel edge (1/2" gap STD). Drill 1/4" holes through the panel using the pre-drilled holes in the bracket as a guide and secure pilaster to panel with torx head sex bolts (with the panel mounted you should have 5 1/2" from the edge of the pilaster to the face of the panel).

Repeat these steps for the rest of your pilasters.

Clean Look: (If noted on shop drawings)
 Plastic brackets receive 3/4" torx screws instead of sex bolts.

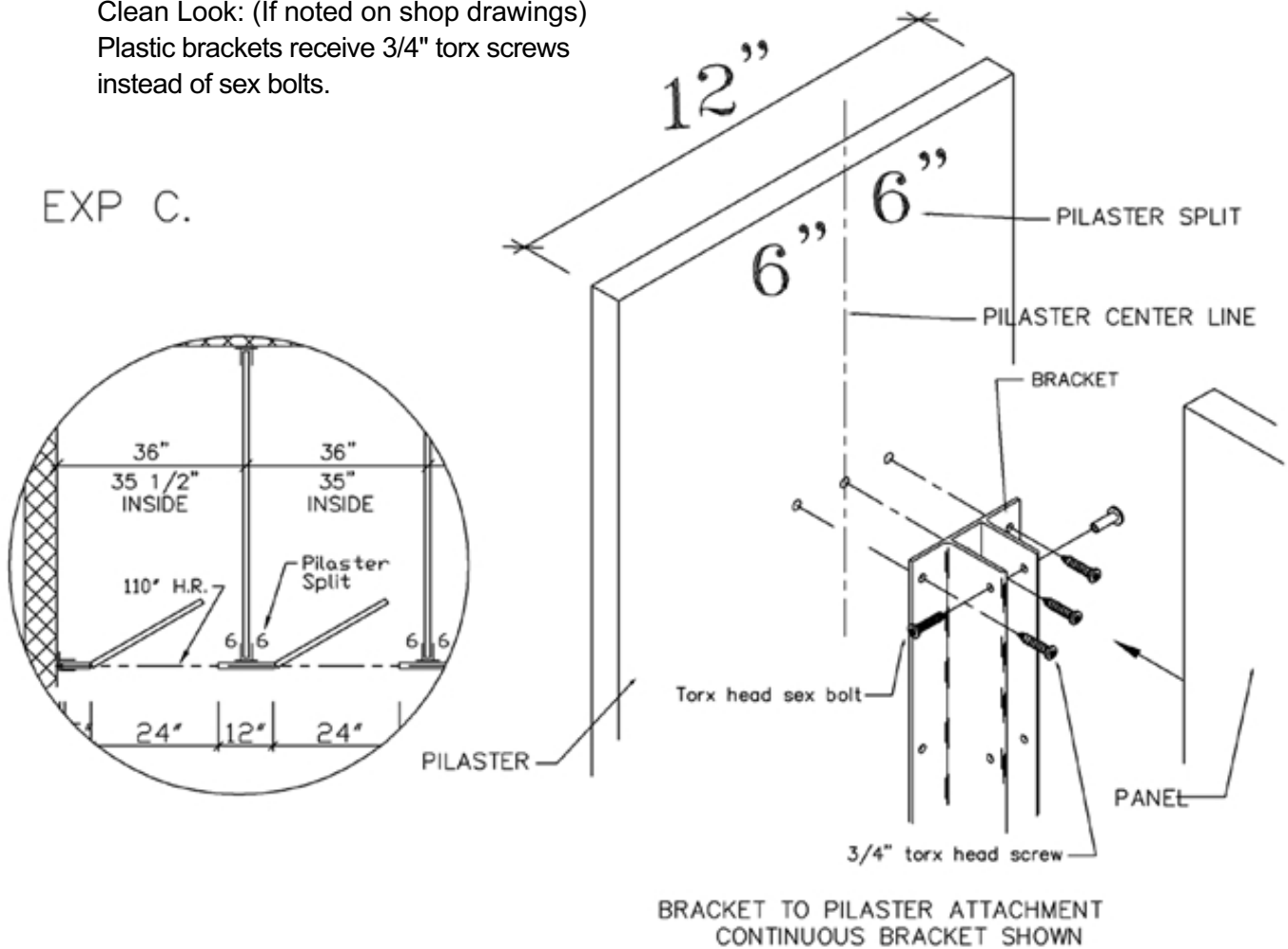

Section 6: Headrail Attachment

Step 1. Cutting Headrail to Size

(Note all headrail shown on your shop drawings is cut by the factory 2" over sized to allow for any variances in the field). Measure the distance that the headrail needs to run for the location you are working on, find the piece of headrail that is shown on your shop drawings for this location and trim it to size.

Step 2. Headrail Bracket to Wall Connection

Place the headrail bracket on the end of the headrail and drill a 1/4" hole through the headrail and secure with a torx head sex bolt. Place the headrail on top of the pilasters (do not attach). Starting at the wall pilaster, slide the headrail against the wall and mark the pre-drilled holes in the bracket onto the wall. Remove the headrail and drill 5/16" holes and insert the plastic anchors. Replace the headrail & bracket and secure it to the wall using 1 1/2" torx head screws.

Step 3. Headrail to Pilaster Connection

On the back side of the pilaster drill a 1/4" hole centered on the pilaster through the headrail ONLY! Then through the hole just drilled in the headrail drill a 5/32" pilot hole 1/2" deep into the pilaster, secure the headrail to the pilaster using a 3/4" torx head screw.

Attention: If shower hooks are used they must be placed in the headrail before the headrail is fastened to the pilasters.

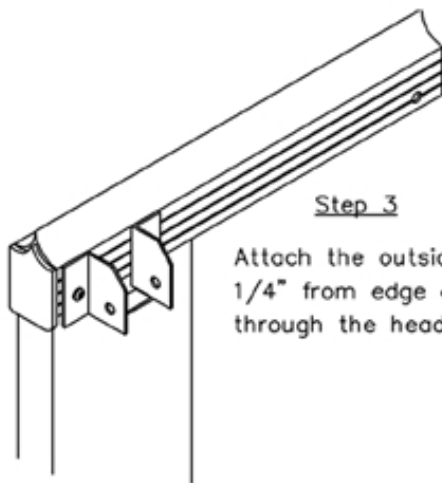

Step 3
Attach the outside ear of headrail bracket approx. 1/4" from edge of headrail. 3/4" screws must attach through the headrail into the pilaster at both ears.

- * HEADRAIL TO PILASTER ATTACHMENT
- * HEADRAIL TO HEADRAIL BRACKET ATTACHMENT
- * HEADRAIL BRACKET TO WALL ATTACHMENT
- * END CAP TO HEADRAIL ATTACHMENT

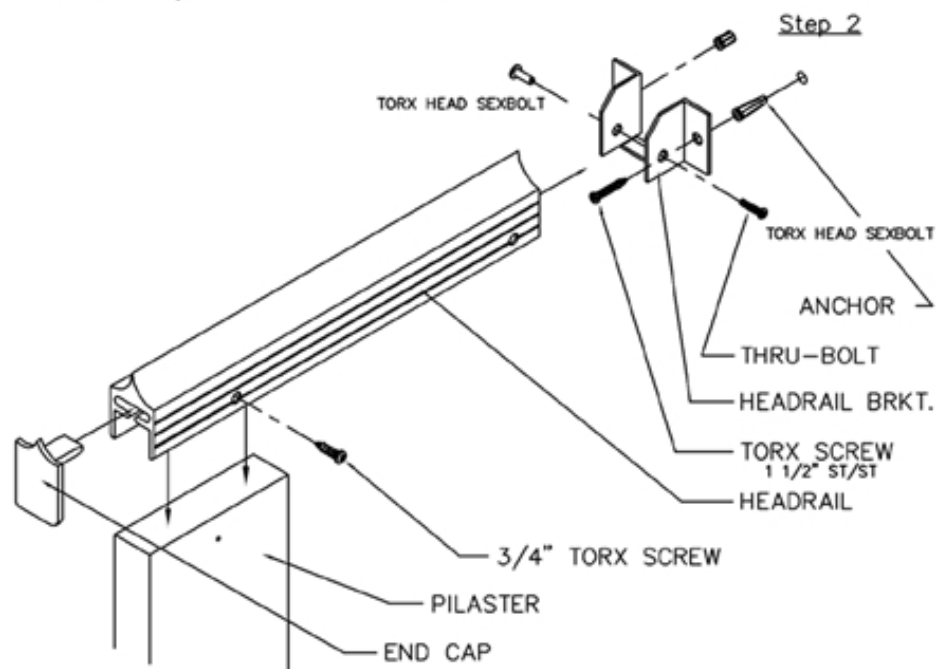

Section 6: Headrail Attachment for Alcove Situations

Step 1. Cutting Headrail to Size (two different ways, choose one)

(Fig. A) Measure across the front of the alcove from wall to wall, and trim headrail "A" to this length.

(Fig. B) Measure from wall to pilaster & cut headrail into two pieces.

Step 2. Notching the Headrail

Take headrail "A" and place it above the pilaster and across the turned pilaster and mark the location where it meets the turned pilaster. Next cut a notch in headrail "A" at the mark where the turned pilaster meets (See alcove dwg). Replace the headrail and secure to the wall using headrail brackets, then using a 1 1/2" torx head screw fasten headrail "A" to turned pilaster through top of the headrail.

Step 3. Return Headrail

Measure from the back side of the headrail "A" to the back wall and cut headrail "B" to this length. Install headrail bracket at the back wall, then insert headrail "B" into headrail bracket and on top of the turned pilaster and secure.

Attention: If shower hooks are used they must be placed in the headrail before the headrail is fastened to the pilasters.

Alcove Dwg.

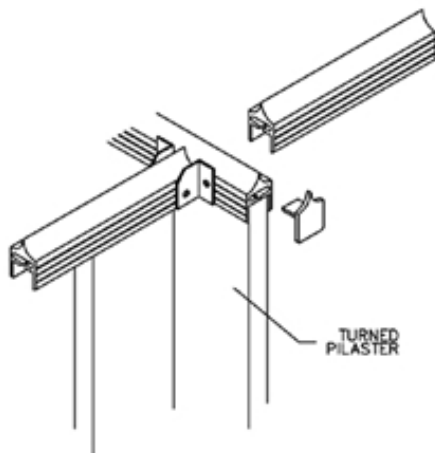
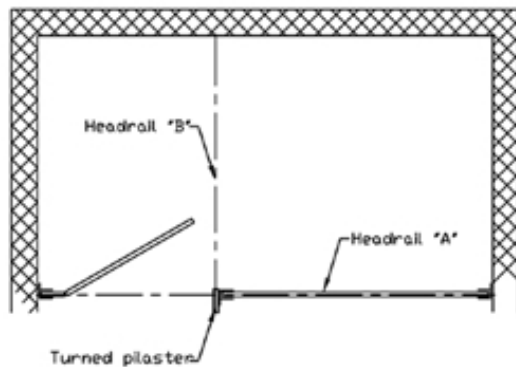

HEADRAIL SPLIT INTO 2 PIECES

Fig. B

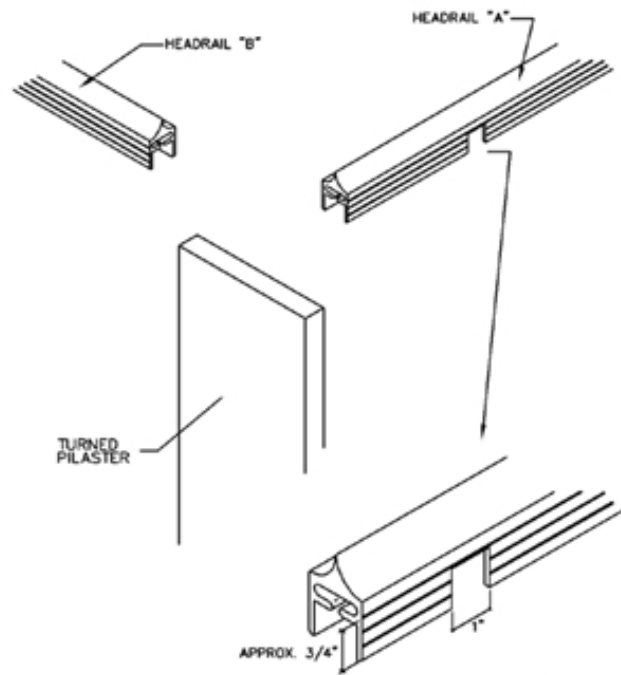

HEADRAIL NOTCH

Fig. A

Section 7: Crossbracing for Ceiling-Hung Pilasters

Note: Plastic crossbracing must be used to stabilize the Ceiling-Hung system and must be installed or “Scranton Products” will not warranty against failure.

Installing Crossbracing

Crossbracing is placed behind the pilasters at 82" above the floor. The length of the crossbracing for its specific location is called out on your shop drawings (crossbracing is cut 2" oversized by the factory to allow for any variances in the field, must trim to size). Place the crossbracing on the back of the pilasters, on top of the 68" high brackets. Where the crossbracing touches the wall(s), mark the location, place the 4" angle bracket against the wall and mark the pre-drilled holes onto the wall. Pre-drill two 5/16" holes on the marks and insert the plastic anchors. Install the 4" angle brackets with 1 1/2" torx head screws. Where the 4" angle bracket touches the crossbracing, pre-drill two 5/32" holes 1/2" deep into the crossbracing. Secure using the 3/4" torx head screws. Where the crossbracing passes a pilaster, pre-drill two 5/32" holes through the crossbrace and 1/2" into the pilasters. Secure using the 1 3/4" torx head screw.

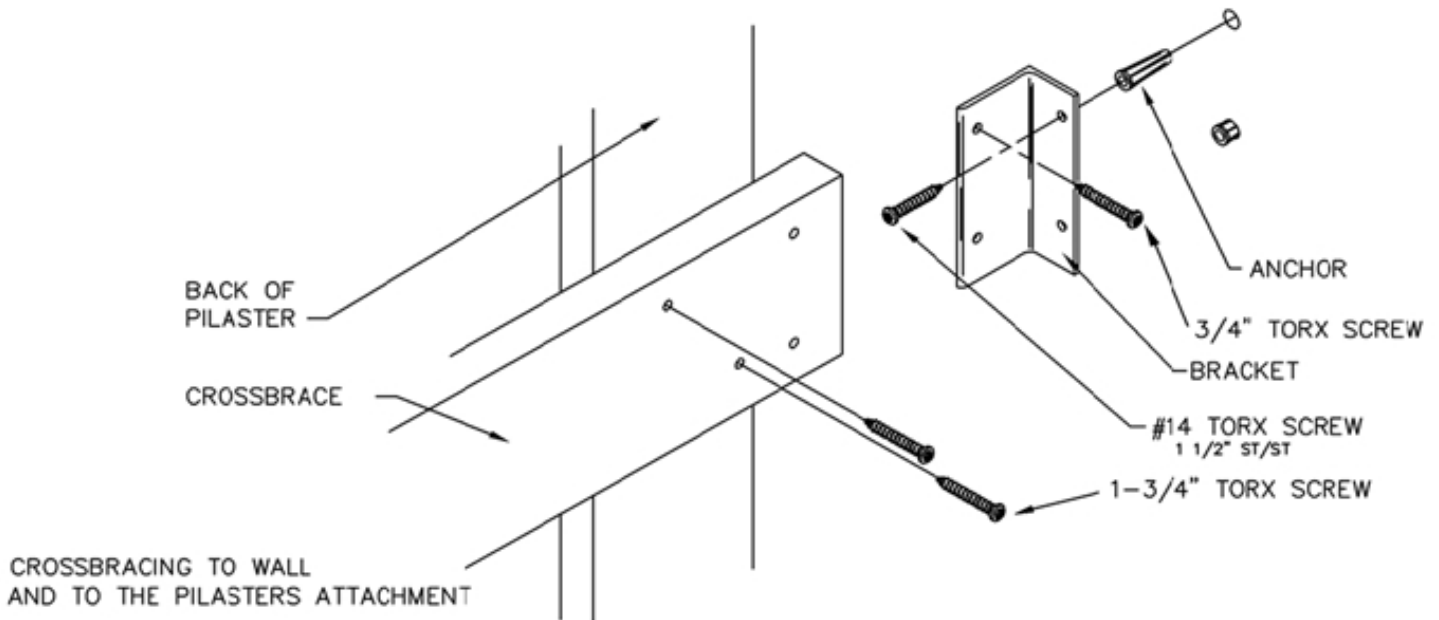

WOODEN DOWEL INSTALLATION

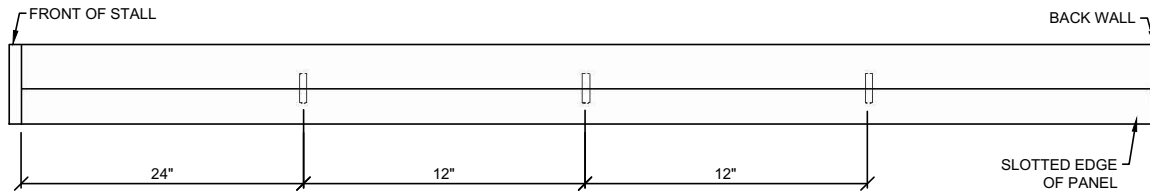

SIDE VIEW

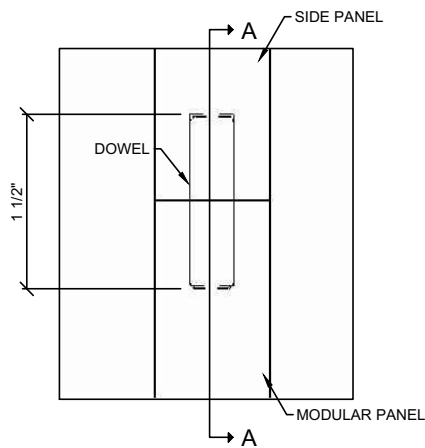

FRONT VIEW

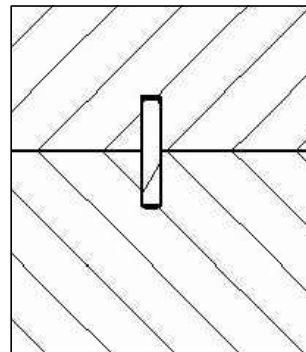

SECTION A-A

INSTRUCTIONS

Install the small modular side panel according to the installation instructions. Mark the TOP EDGE of the small modular side panel 24", 36" and 48" from the FRONT EDGE. Note: The front edge of the panel WILL NOT be slotted. At the marks, measure the panel thickness and mark the center of the panel. Using a 3/8" drill bit, drill a hole on the marks approximately 7/8" deep. Be sure to hold the drill as straight as possible.

Insert the 3/8" x 1-1/2" wooden dowels in the holes.

Mark the BOTTOM EDGE of the large modular side panel 24", 36" and 48" from the FRONT EDGE. The front edge of the panel WILL NOT be slotted. At the marks, measure the panel thickness and mark the center of the panel. Using a 3/8" drill bit, drill a hole on the marks approximately 7/8" deep. Be sure to hold the drill as straight as possible.

Align the holes in the bottom edge of the large modular side panels with the wooden dowels. Align the slotted back edge of the panel with the wall bracket leg. Use a rubber mallet on the top and front edge of the panel until the seam between the panels is tightly closed and the front edge of the panel is flush with the front edge of the post.

Section 8: 76" Stiffener Installation

The 76" Stiffener is used to provide added support to the pilaster for spans greater than 30" on the strike side of a pilaster, or 10" spans or greater for HC doors. Locations will be shown on shop drawings.

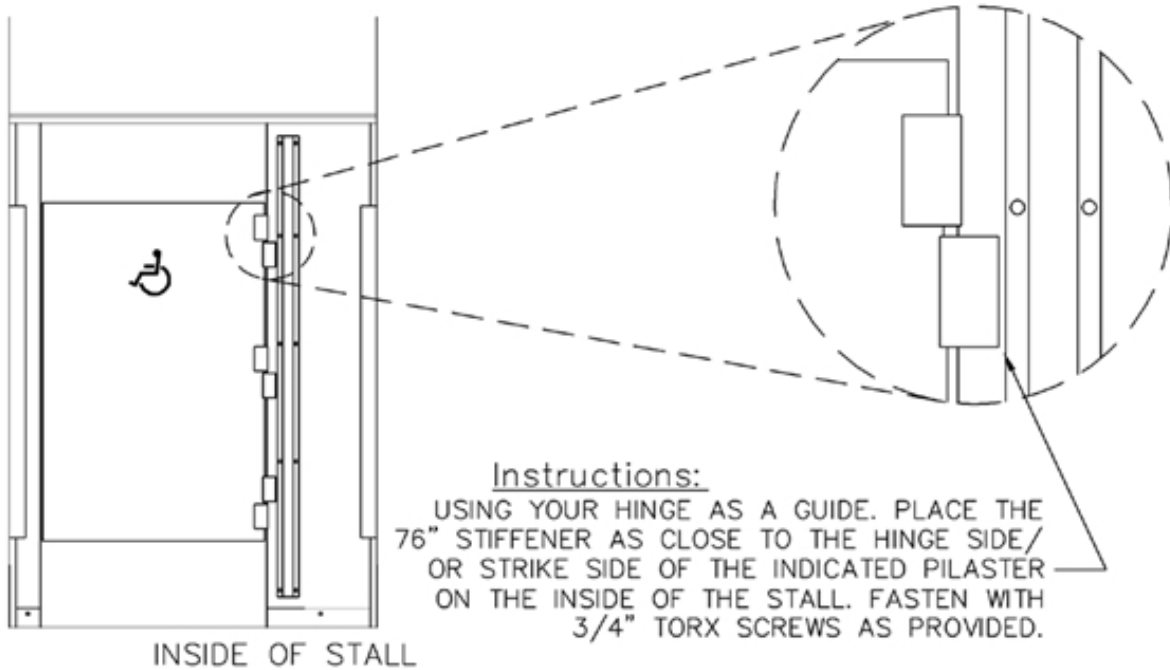

STD. FRONT ELEVATION

N T S FOR REFERENCE ONLY

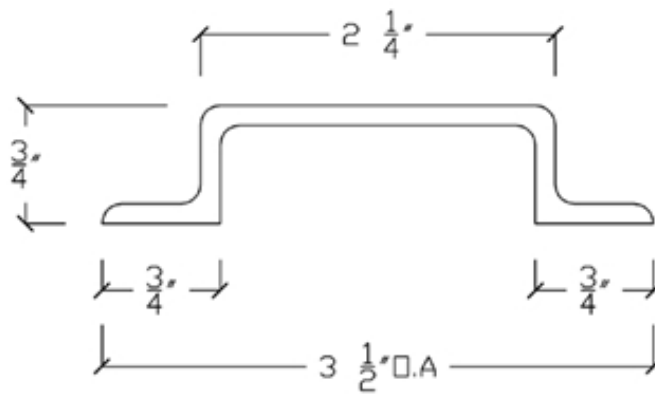

CROSS SECTION

Section 9: Hinge Installation (Integral Hinge)

Stealth "L" Bracket: The Stealth "L" Bracket plate is to be mounted at the top and bottom of each door, and the top and bottom of each integral cut pilaster. Using the hinge as a guide, align the hole in the bracket with the hole in the pilaster or door. Pre-drill using a 3/32" bit and fasten with the #8 3/4" screws provided. Do not fully tighten the bracket down until the rest of the hinge pin installation is complete.

Bottom Hinge: Insert the long cammed pin into the bottom of the door as indicated at point "A". Be sure the pin bottoms out using the short cammed pin to push the long cammed pin into the door. Drill a pilot hole (3/32" bit) approx. 1 7/16" deep into the door as indicated at point "B". Be sure to drill deep enough to penetrate the cammed pin in the door. Drive the set screw flush with the door's surface. Insert the short cammed pin into the bottom of the pilaster at point "C".

Top Hinge: Insert the spring at point "D". Then the long pin at point "E" into the top of the door. Position the door into the pilaster cutout so that the long & short cammed pins (bottom) engage each other and the long pin (top) is placed into the hole and "tops out" in the pilaster. Drill a pilot hole "F" (3/32" bit) into the pilaster. Be sure to drill deep enough (1 7/16") to penetrate the pin in the pilaster. Drive the set screw flush with the pilaster's surface. Next, rotate the door to the desired rest position. Push down on the door while holding it in the desired rest position. (This sets the cammed pins in the bottom set). Drill pilot holes at point "G" same as "B" (as noted above) and continue to hold the door at its desired rest position. Drive the set screw flush with the surface.

Safety Note: Protective eyewear must be worn while installing hinge pins! Spring compression may expel hinge pin rapidly causing injury.

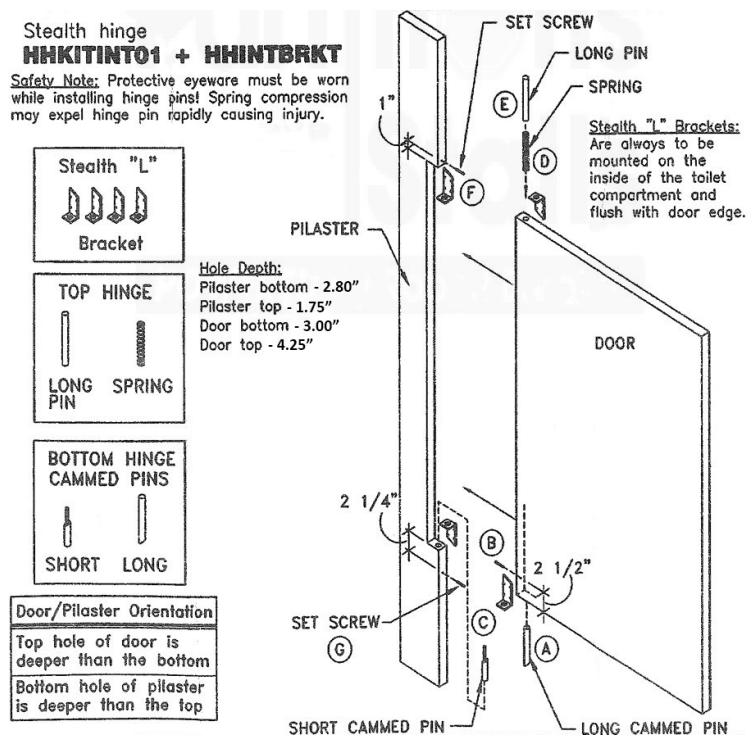

STEALTH INTEGRAL SURFACE MOUNT HINGE

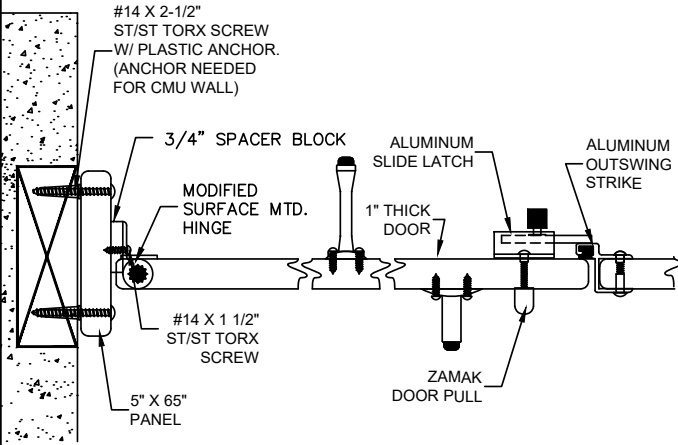

Plan Elevation

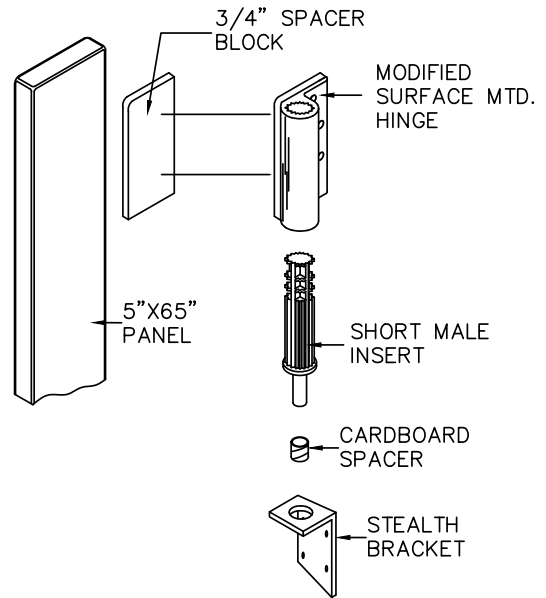

TOP HINGE

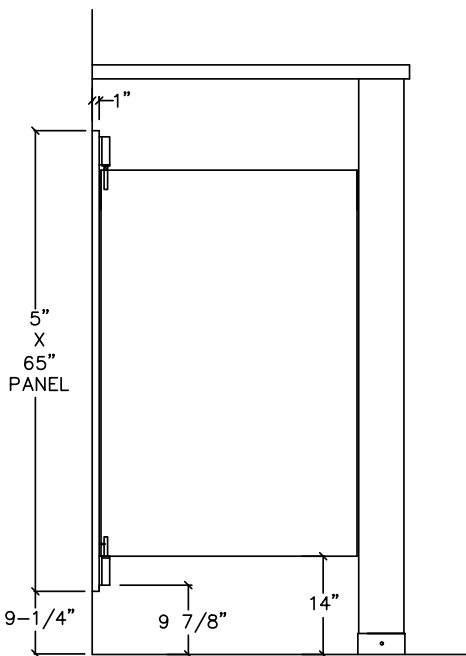

Side Elevation

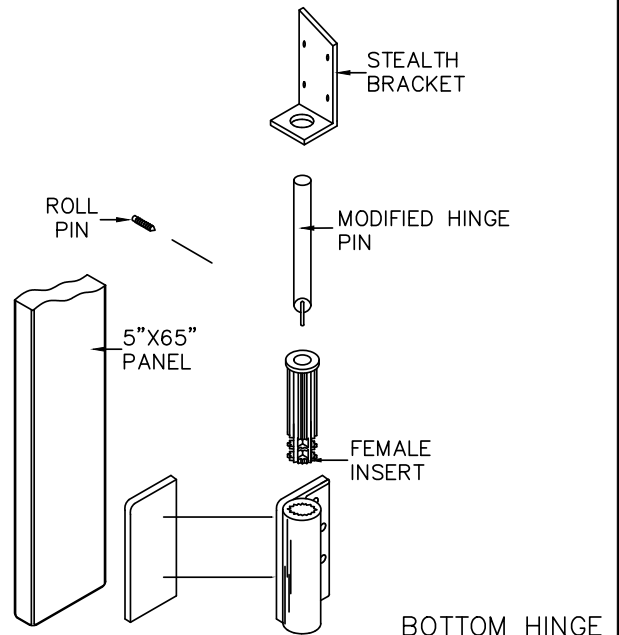

BOTTOM HINGE



SCRANTON
PRODUCTS



HINY
HIDERS

801 E COREY ST. SCRANTON, PA. 18505 Phone (570)348-0997

STANDARD ELEVATIONS

*Hinge shown is for inswing or outswing doors, door hardware shown is for outswing.

Actual door sizes will be 1/2" smaller than sizes shown on shop drawings.

Note: "Job-Specific Specifications" for all orders are located on the top of the shop drawing layouts.

SURFACE MOUNTED HINGE INSTALLATION INSTRUCTIONS

1. Using the supplied 2 1/2" torx head screws attach 5"x65" Panel to wall @ 9-1/4" A.F.F., standard.
2. Attach the Bottom Hinge to the Panel with the 3/4" spacer block behind it @ 9-7/8" A.F.F from the bottom of the Hinge.
3. Set the Female Insert in the Bottom Hinge, and using Hiny Hiders Instruction Manual, set for either open or closed.
4. Next set the Modified Hinge Pin into the bottom of the door, again using the Instruction Manual, install the Roll Pin.
5. Holding the door in place on the bottom hinge, install the top hinge with the cardboard spacer into the top of the door.
6. Now attach the top hinge and the 3/4" spacer to the Panel, and then remove the cardboard spacer.

Section 9: Hinge Installation (Vault Hinge)

Vault Hinge

1. Remove hinges from package, then discard u shaped shim in each hinge
2. Take both hinges apart A from C and B from D
3. Line up hinge parts A&B with top corner as show & bottom of door. Using the parts as a template, predrill with $\frac{1}{4}$ " drill bit for parts A and B. Remove swarf and debris created from predrilling the hole.
4. Mount hinge parts A&B to the door with through bolts.
5. Mount part D 1.25" on pilaster below specified AFF. Insert similar instruction form line 3
6. Place assembled door with A&B attached, inserting hinge part B into hinge part D
7. Place hinge part C, place on pilaster and slide onto hinge part A
8. After mounting hinge part C onto hinge part A. Move hinge part C up $\frac{5}{8}$ " in preparation to mount to pilaster. Check door for level and consistent gapping then predrill 1 hole with $\frac{1}{4}$ " drill bit and fasten with through bolts.
9. Check for door function and adjust cam so door comes to rest positions at desired degree of open
10. Drill 2nd hole in hinge part C and fasten with through bolts

Tips:

To change from inswing to outswing: remove latch, change cam degree.

If hinge halves do not tighten against pilaster and or door. Use provided tape to tighten this up.

8" Hinge

Please see separate sheet that is included with you 8" hinge packages for installation and field setting.

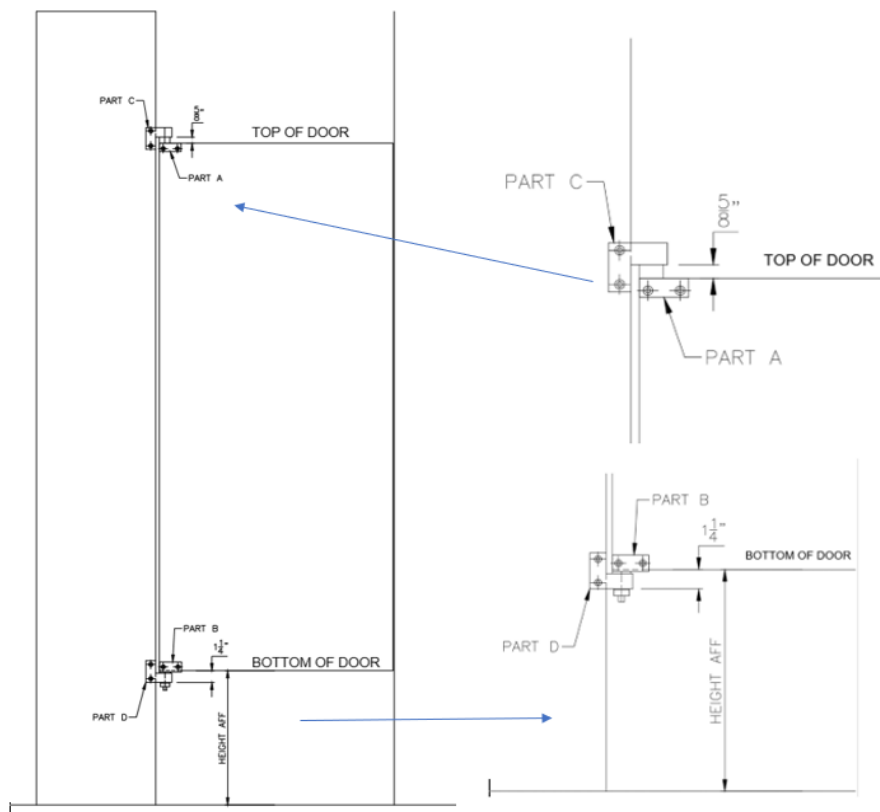

8" Aluminum Hinge installation

NOTE: DO NOT REMOVE THE CARDBOARD SPACER FROM THE BOTTOM HINGE UNTIL AFTER INSTALLATION OF THE DOOR IS COMPLETE.

Top hinge: Install the top part of the top hinge to the door. Mount it 2" down from the top of the door. Secure it by first drilling a $\frac{3}{32}$ " pilot hole $\frac{1}{2}$ " deep into the edge of the pilaster. Secure the hinge to the door with the 1" st/st #8" hinge screw. Drill $\frac{1}{4}$ " holes through the pre-drilled holes in the hinge through the face of the door. Secure the hinge to the door with the st/st sex-bolts.

Bottom hinge: Install the bottom part of the bottom hinge to the door. Mount it 2" up from the bottom of the door. Secure it to the door the same way as the top hinge.

Using a 14" x 14" spacer block (not provided) to support the door, place the door between the pilasters. Secure the bottom part of the top hinge to the pilaster, and then secure the top part of the bottom hinge to the pilaster.

NOTE: The top hinge contains the cam mechanism. The cardboard spacer between the bottom hinge must be removed after installation.

8" Aluminum Hinge (Top, & Bottom Hinge)

HHKITAL01CLR

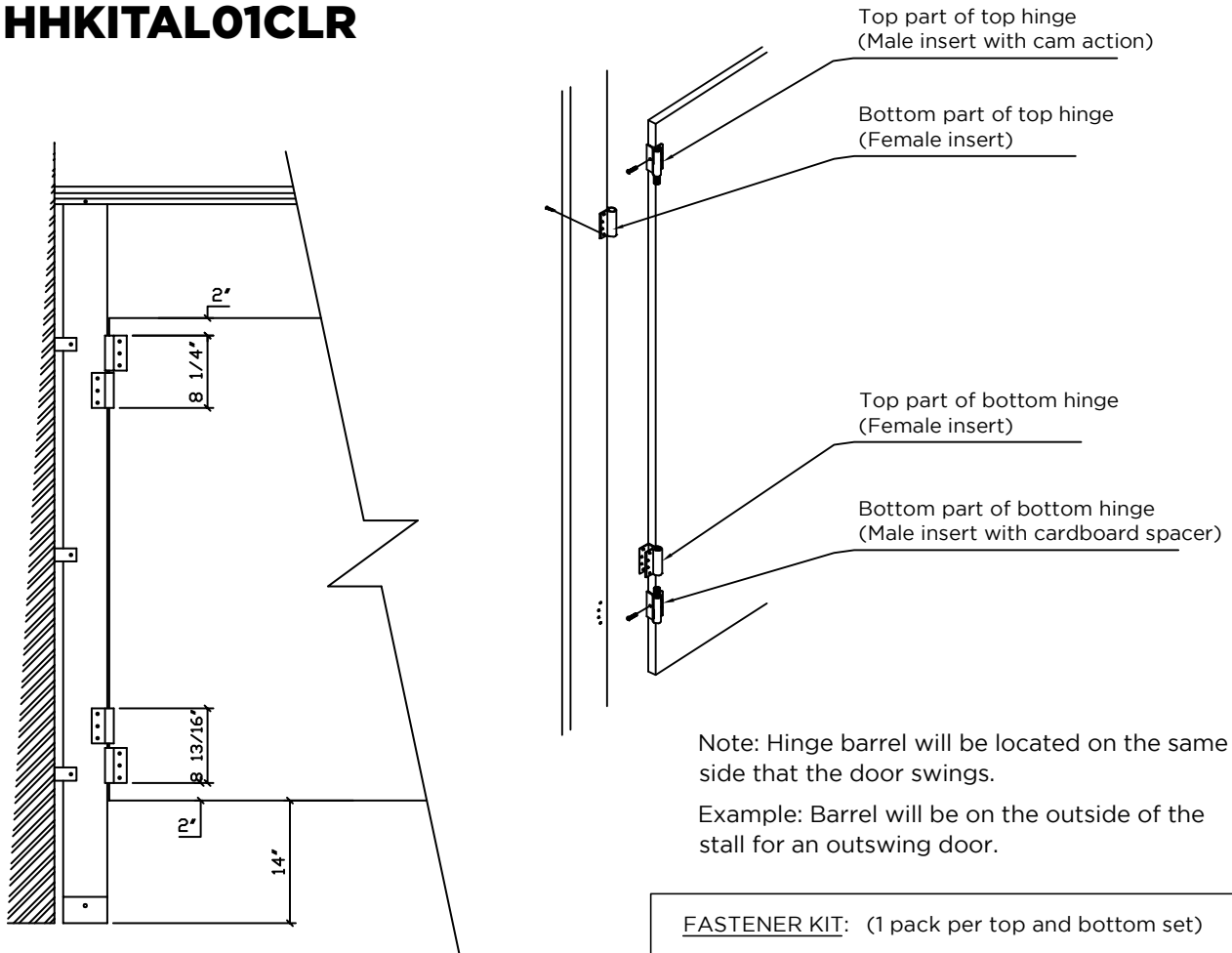

FASTENER KIT: (1 pack per top and bottom set)

Kit Item# HFPKHG02

QTY.	ITEM#	DESCRIPTION
8	A HF843SBM	.830 SEXBOLT, MALE
8	B HF718SBF	.830 SEXBOLT, FEMALE
2	C HF1HSS	1", #8" HINGE SCREW

8" Aluminum hinge Open & Closed Adjustments

Make note that the hinge blanks and inserts have reference marks used in setting the hinge position.

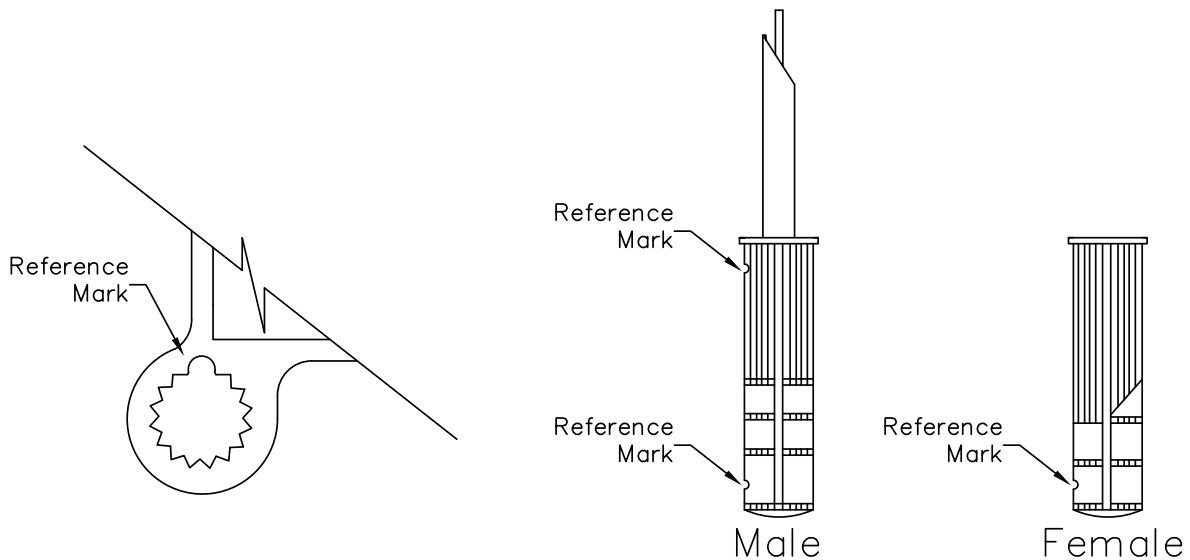

(1) Insert the female into the hinge blank, for top and middle sets, so the reference marks align.

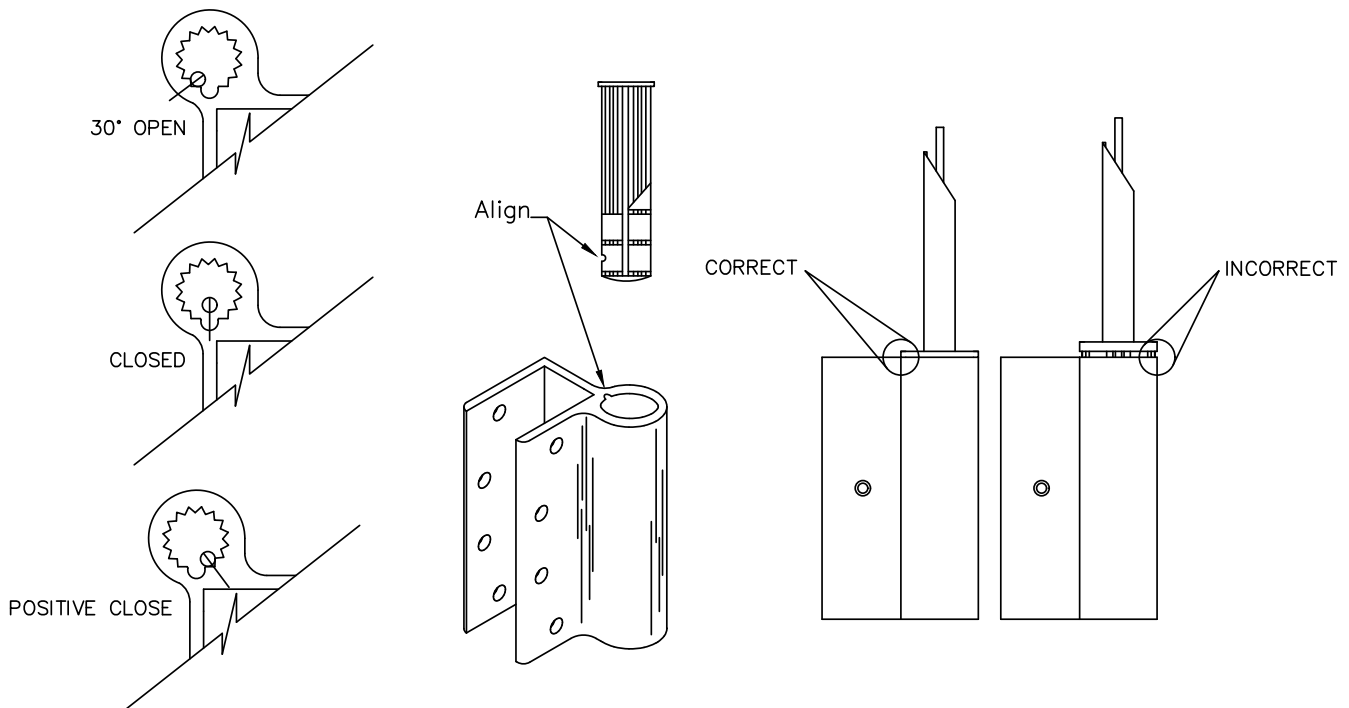

(2) Adjust the degree of the hinge's rest position (30° increments) by moving the position of the male insert into the hinge blank (top set).

(2a) Closed position: insert the male insert into the the hinge blank so that the reference marks align.
 Note: for a positive close, set the insert to the -30° position. (Do not exceed -30°)

(2b) 30° open position: Insert the male insert into the the hinge blank so that the reference mark of the insert aligns one position from the blank reference mark as shown. (See closing chart)

(3) The hinge collar should fit tightly against the hinge blank as shown.

54" Continuous Aluminum Hinge

The standard 54" aluminum hinge is surface mounted and fastened with 3/4" torx head screws. Each hinge has removable covers that are applied after mounting and set with a setscrew. To mount measure up 14 1/2" from the floor on the pilaster and mark, this is where the bottom of the hinge will be located (See EXP. A for setting the gap between door and pilaster) when proper gap is set, put a mark on the pilaster using the top pre-drilled hole in the hinge as a guide. Remove hinge and drill a 5/32" pilot hole 1/2" deep at the mark, replace hinge and fasten with a 3/4" torx head screw, repeat for rest of holes.

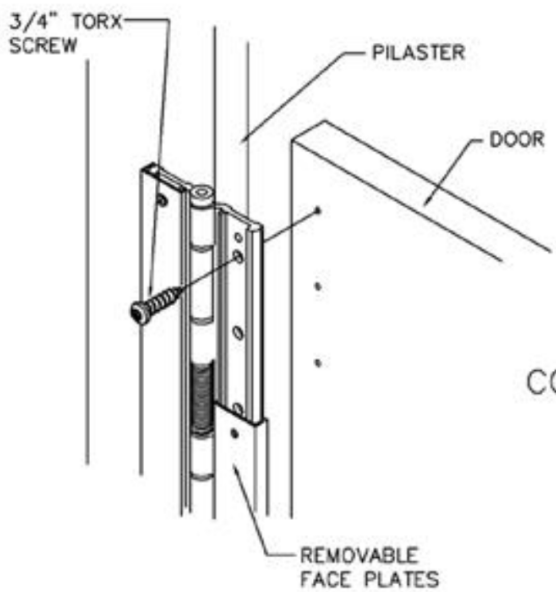
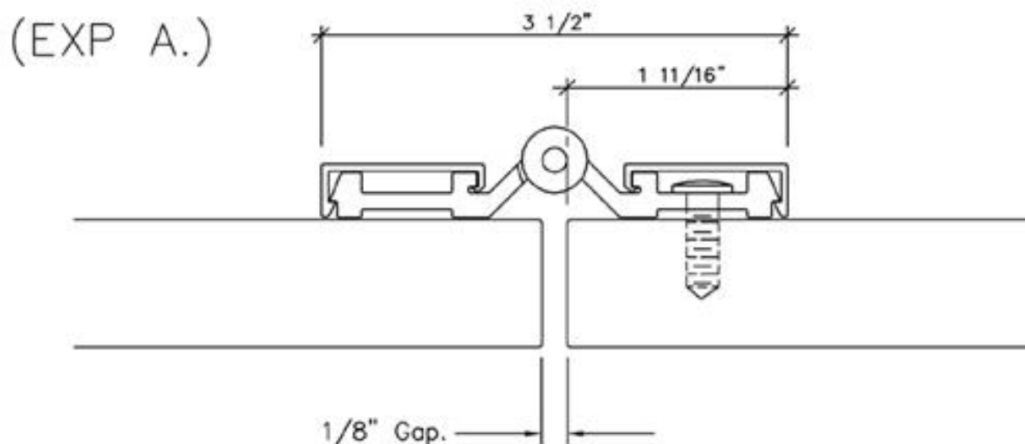

CONTINUOUS HINGE
ATTACH THE HINGE TO THE DOOR AND
PILASTER WITH #14 X 3/4" TORX
SCREWS.

ST/ST Hinge

The ST/ST 54 1/2" hinge is surface mounted and fastened with 3/4" torx head screws. The hinges are set for either 15° opening or set to close. Doors 30" or over require the doors set to closed position, so whether they are in-swing or out-swing doors the hinge set to close must be used. To mount, measure up from the bottom of the pilaster 14 1/2" and mark; this will be the location of the bottom of the hinge (See EXP. A). Measure in from the edge of the pilaster toward the center 1 7/16" and make a mark parallel with the pilaster edge, place your hinge against the pilaster on these two marks and mark the pre-drilled hole locations from the hinge onto the pilaster. Remove the hinge and drill a 5/32" hole 1/2" deep into the pilaster on the mark. Replace the hinge and secure with a 3/4" torx head screw. Pilot drill the rest of the holes on the pilaster side of the hinge and secure. Set your door 14" above the finished floor, with a 1/8" gap between the door and pilaster, secure hinge to door in same fashion as above.

(EXP A.)

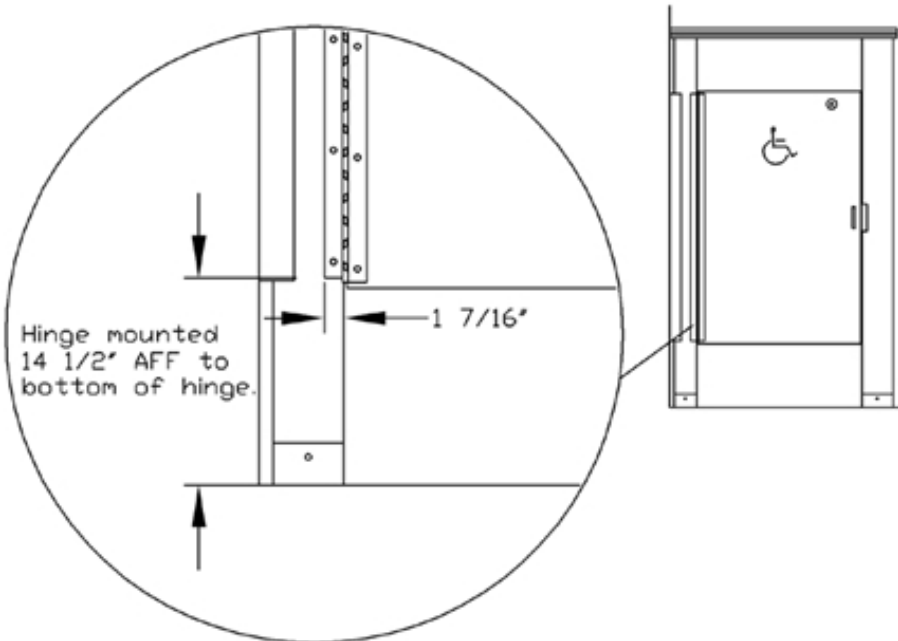
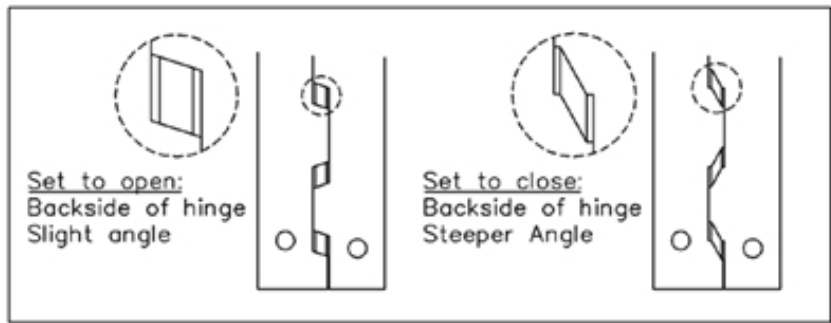

When hinges are installed, the hinge will have a 1/4" offset when in the rest position. This allows for the door to lift when opened, allowing gravity to return the door to the set position.

Note: Hinges are provided for H/C stalls to return to the closed position. Standard in-swing stalls are supplied to return to 15 degrees open. Hinges are not field adjustable.

Section 9: Hinge Installation (54"-71" Stainless Steel Hinge Surface Mount)

PLAN ELEVATION - INSWING

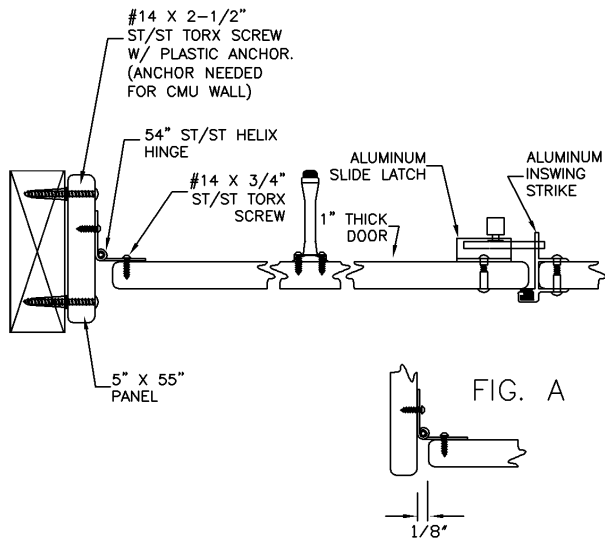

PLAN ELEVATION - OUTSWING

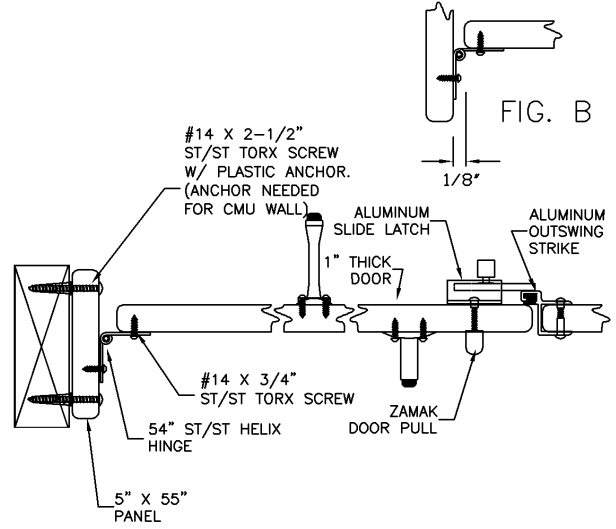

INSWING

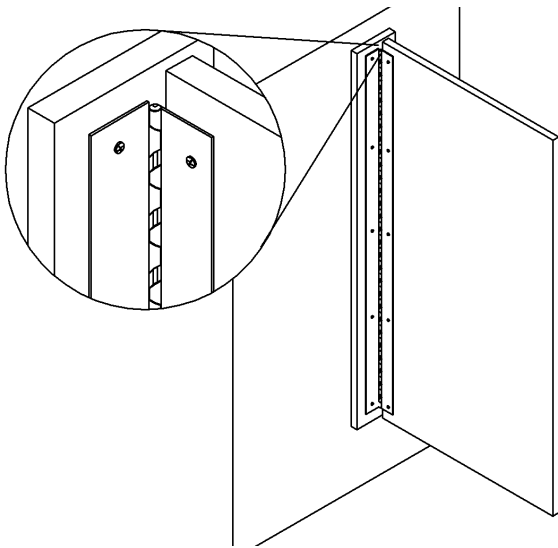

OUTSWING

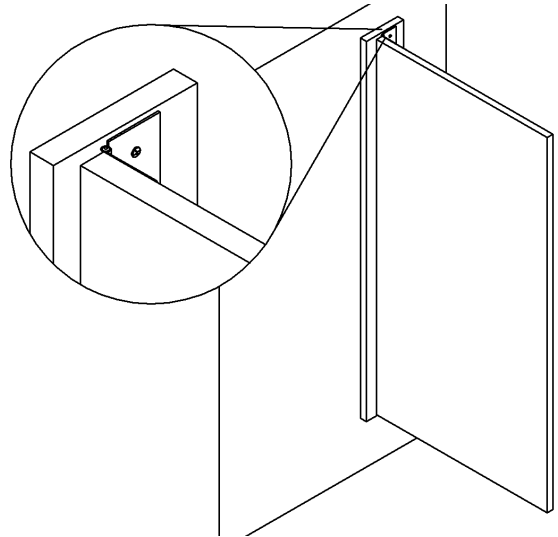

Surface Mounted Hinge Installation Instructions

1. Using the supplied 2 1/2" torx head screws attach the 5" x 55" panel to the wall at 14" above the finished floor, standard.
2. Using the 3/4" ST/ST torx screw attach the hinge to the panel.
3. Using the 3/4" ST/ST torx screw attach the door to the hinge with an approx. 1/8" gap between the door and panel surface. (fig. A or fig. B)

NOTE: Job-Specific Specifications for all orders are located on shop drawing layouts.

(Drawings are not to scale)

Section 10: Coat Hook & Bumper Installation

INSWING DOORS: The coat hook is installed on the inside of the door in the upper corner opposite the hinge side and

- A.) 48" above the floor (ADA) or
- B.) 5" down from the top of the door (Non-ADA)

So when the door is in the full open position the button on the slide latch does not hit the wall/panel.

OUTSWING DOORS: The coat hook should be centered on the inside of the door and be

- A.) 48" above the floor (ADA) or
- B.) 5" down from the top of the door (Non-ADA).

BUMPER (Wall Stop): These are supplied only for out-swing doors and are installed in the upper top corner about 3" down from the top of the door opposite the hinge side, so that when the door is fully open the door pull handle does not hit the wall or partitions.

To secure the coat hook & bumper, drill 1/8" pilot holes 1/2" into the door. Secure with #10x5/8" one-way screws.

Coat hook (non-ADA doors)

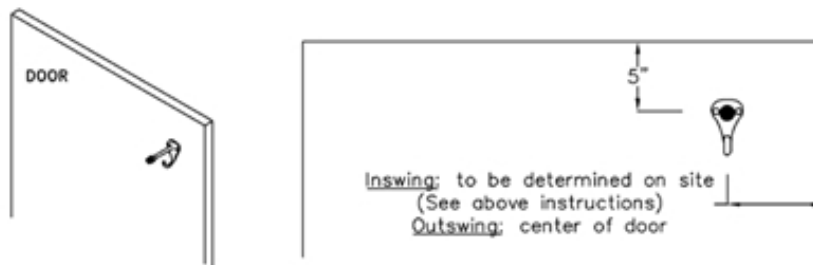

Coat hook (ADA doors)

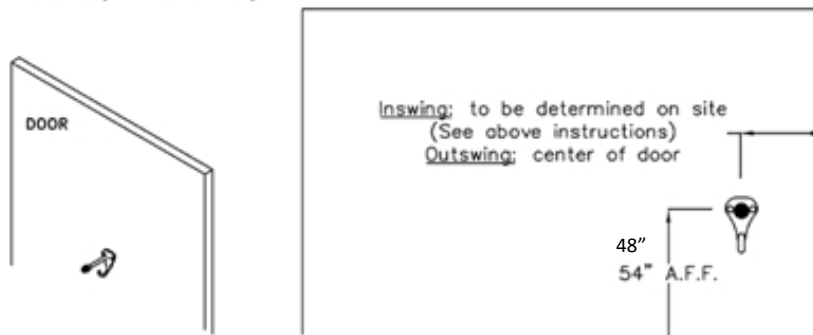

Coat Hooks - ADA CODE 308.2.1 Unobstructed. Where a forward reach is unobstructed, the high forward reach shall be 48 inches (1220 mm) maximum and the low forward reach shall be 15 inches (380 mm) minimum above the finish floor or ground. Scranton Products recommends checking with state and local codes to ensure ADA compliances.

Wall stop bumper (outswing doors)



Section 11: Vanity Installation

Step 1. Marking Vanity Locations

Measure up the back wall 33" and make a mark, then measure out parallel with the floor the distance of the vanity as indicated on your shop drawings and make a chalk line, this will be where the bottom of the vanity top will sit. Indicate on the walls where the vanity center support(s) and end leg(s) will be. Space the supports evenly, (do not exceed 36") keep in mind the location of the plumbing fixtures. (See EXP. A)

Step 2. End Supports (only on in-corner and free standing)

Set the end support in place against the wall on the line indicated in the previous step. Mark around the bottom of the leg for the location of the shoe. See the separate installation sheet supplied with the shoes to install the shoe at this time. Attach a 16" angle to the inside back of the support and one to the inside top of the support, pre-drill the holes with a 5/32" drill bit and secure with 3/4" torx head screws. (See EXP. B & EXP. C next page). After the brackets are attached to the end support, insert it into the shoe. Make sure it is level and plumb, and mark the hole locations from the brackets onto the wall, then remove the support. Drill 5/16" holes at the hole locations and insert the plastic anchors. Replace the support and fasten with 1 1/2" torx head screws, fasten shoe with a sex bolt (See EXP. C next page).

EXP A.

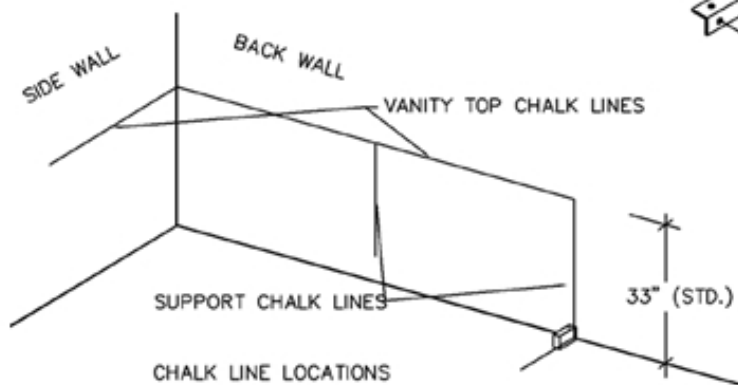

EXP B.

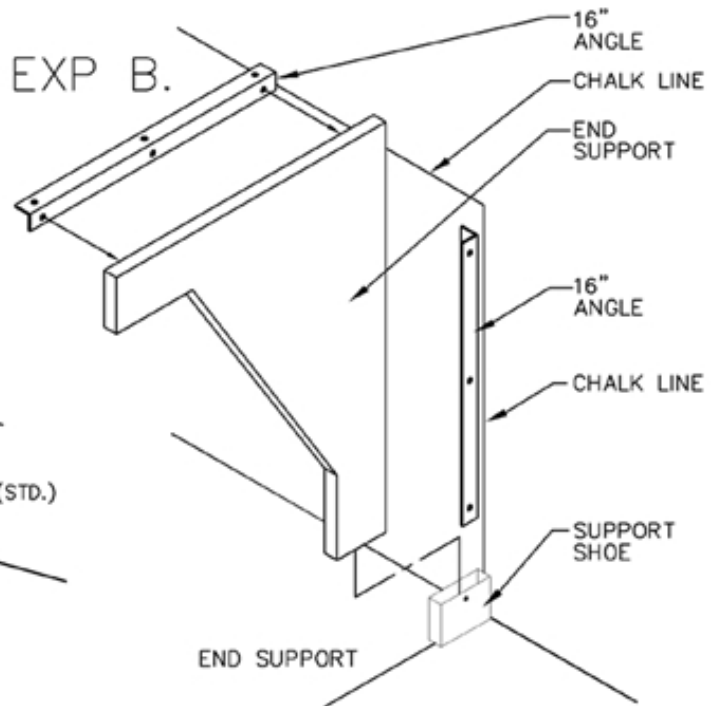

Section 11: Vanity Installation Continued

Step 3. Center Supports

Attach a 16" angle bracket to the back of the support and one to the opposite side on the top of the support. Secure in same fashion as in step 2, previous page. (See EXP. C) After the brackets are attached to the support, take the support and center it on the chalk line on the wall making sure it is level, and the top of the support is flush with the line for vanity top. Mark the holes for the brackets onto the wall and secure to the wall in same way as in step 2, previous page. (See EXP. C)

Step 4. Wall Brackets

Between the center support(s), end support(s) and at the side wall, install the 16" angle brackets flush and level with the chalk line for the bottom of the vanity top, evenly space throughout (See EXP. E)

EXP C.

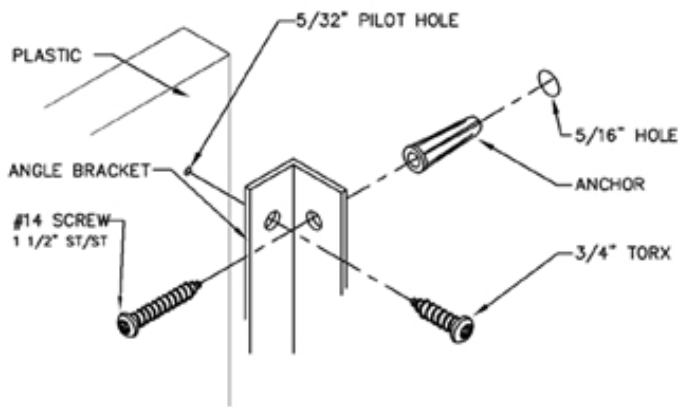

EXP D.

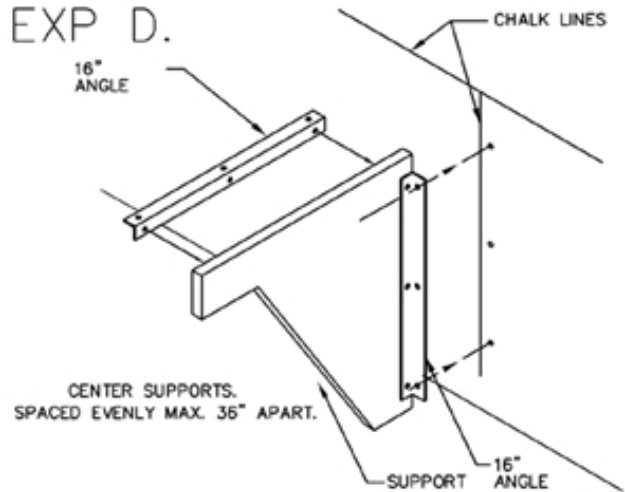

EXP E.

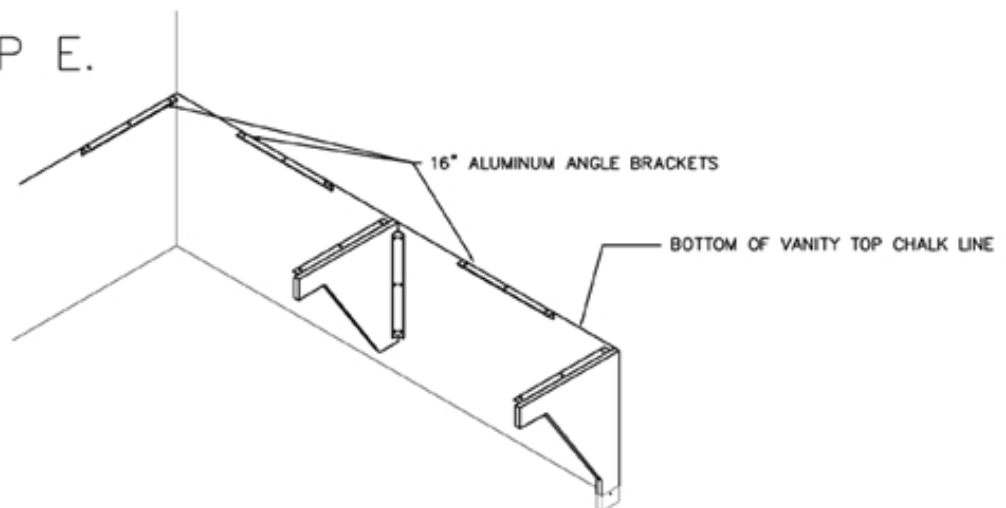

Section 11: Vanity Installation Continued

Step 5. Back splash & Side splash

Install the back splash & side splash(es) to the vanity top. Clamp or hold the back splash to the back edge of the vanity top. From the bottom pre-drill 5/32" holes 2" deep through the vanity top and into the back splash, space holes approximately 10" apart. Drill a 5/16" countersink 1/8" deep. Secure the back splash to the top using 2 1/2" torx head screws. Install side splashes same as back splash. (EXP. F)

Step 6. Vanity Top

After the back splash and side splash are installed, position the top onto the support and angle brackets. Make sure that it is tight against the back wall. From underneath, drill 5/32" pilot holes through the brackets up 1/2" deep into the vanity top and fasten with the 3/4" torx head screws.

Step 7. Skirts

Attach to the back of the skirt the 16" angle brackets approximately the same distance as the ones on the back wall. Drill 5/32" pilot holes 1/2" deep into the skirt and attach with 3/4" torx head screws. Place the skirt into position against the supports and up to the vanity top and drill 5/32" pilot holes from the brackets 1/2" deep into the top. Fasten with 3/4" torx head screws. Use the small 2" x 2" angle brackets to attach the skirt to the supports. (EXP. G)

Step 8. Kickplates

Attach to the supports by drilling 5/32" pilot holes 2" deep through the front of the kickplate into the supports. Fasten with the 2 1/2" torx head screws.

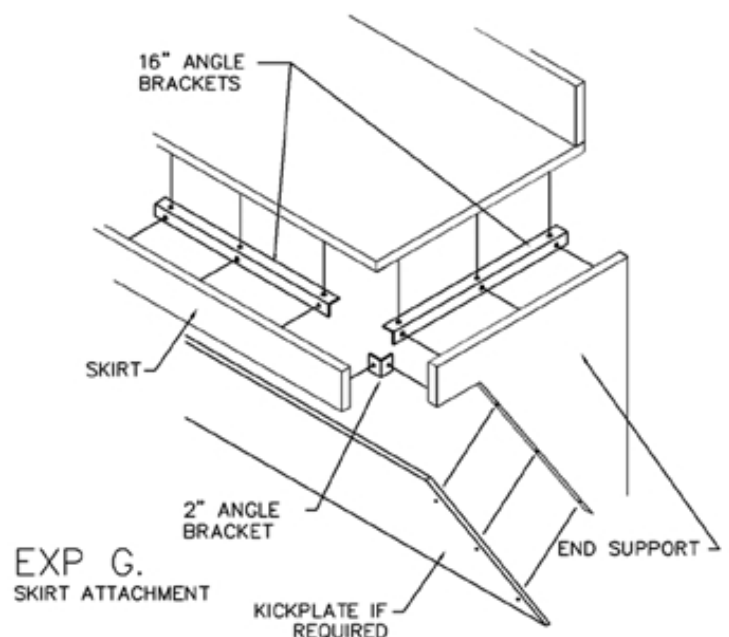
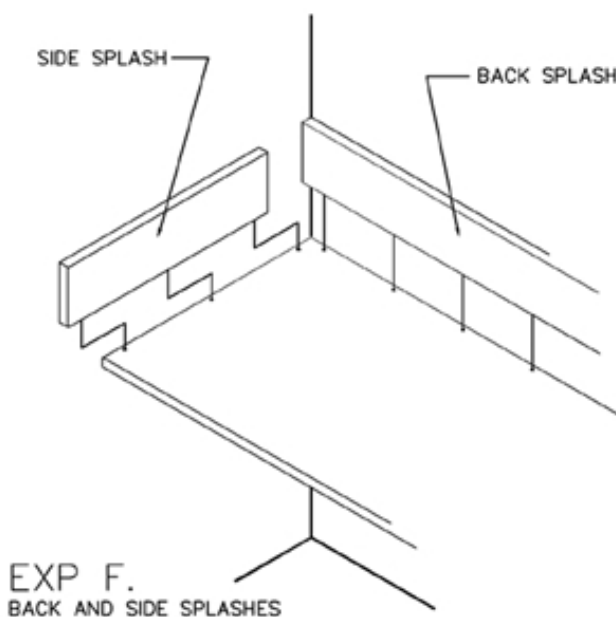

Section 12: Locker Bench Installation

Step 1. Pedestal to Bench

Using the bottom side of the bench, indicate the centerline along the length of the bench. Along the centerline mark 12" in from each end of the bench. Then divide the distance between these two marks equally. (Never exceed 36" between pedestals). These marks will indicate the centerline locations of the pedestals. Set the pedestals in place and pre-drill the holes with a 1/8" bit 1/2" deep into the bench and secure with torx head screws. (See EXP. A)

Steel Pedestals—3/4" torx head screws

Plastic Pedestals—1 3/4" torx head screws

Aluminum Pedestals—1 3/4" torx head screws

Step 2. Pedestal to floor

Set the bench with pedestals attached in place on the floor. Mark the floor where the pedestal holes are located. Remove the bench and drill 1/2" holes at these locations and insert the lead anchors. Replace the bench and secure to the floor with the 2" st/st machine bolts supplied. (See EXP. B)

(EXP. A)

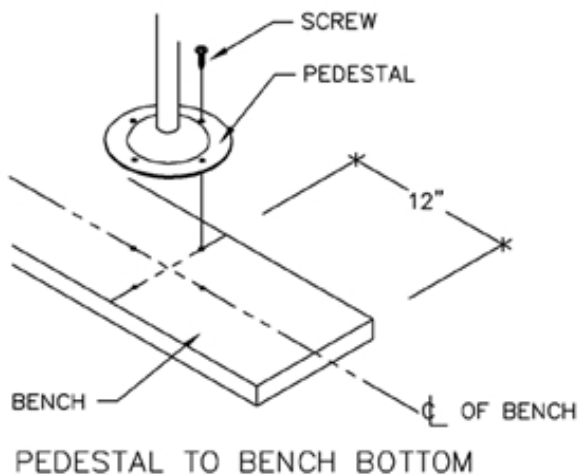

(EXP. B)

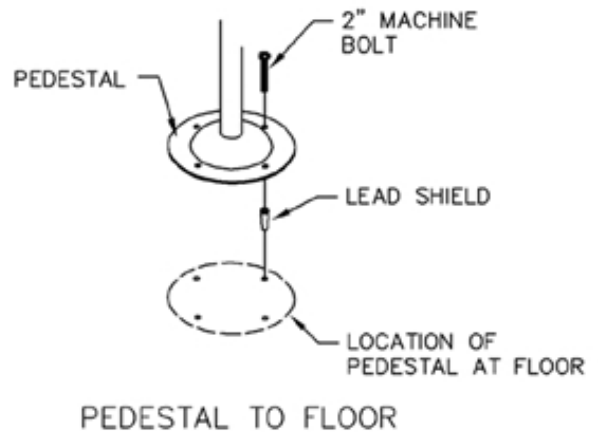

Section 13: Terrazzo Base / Shower Cube

Scranton Products designs shower cubicles to be mounted on terrazzo bases. All terrazzo bases are by others and not supplied by Scranton Products. Below are two typical base designs used with our cubicles.

Be sure to use a substantial bead of caulk between our plastic panels and the terrazzo base forming a custom gasket. A substantial bead of caulk must be applied, during installation to insure proper seal. Caulk applied after installation is complete will not provide sufficient seal, this must be done prior to setting panels.

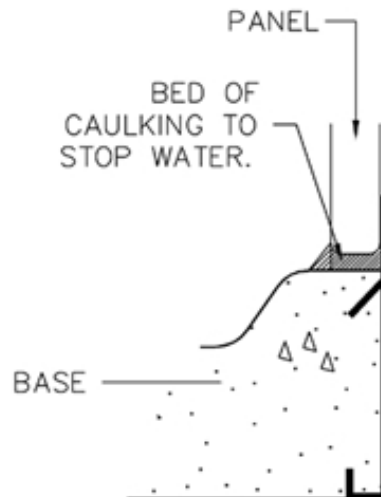
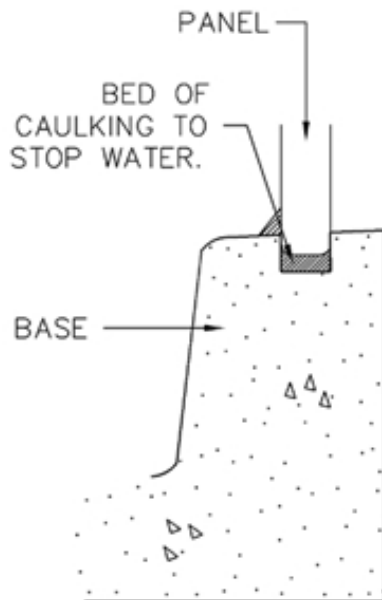

Keeping your plastic lockers and partitions beautiful for years is easy!

Here's how:

DIRT & GRAFFITI

Your Scranton Products (Santana/Comtec/Capitol's) plastic products can be cleaned satisfactorily by using water and a mild cleaner. Avoid using any abrasive cleaner, brush or other item that could scratch the surface. **(Note: use of cleaning product that include Acetic Acid/Vinegar are not recommended for cleaning)**

It is also a good idea to test any product on a scrap piece or inconspicuous area of the partition to make sure it does not harm the surface.

When the soiled areas are stubborn, the following cleaning solutions are suggested:

- 1/2 cup of household detergent, 2/3 cup of trisodium phosphate, and 1 gallon of water
- Any industrial strength cleaner (Non-abrasive)
- For glue that sticks from the masking use Mineral spirits or Acetone.

Avoid contact with the hardware.

CUT & SCRATCHES

Repair cuts and scratches by burnishing the surface with a smooth round object, such as a spoon or screwdriver handle. Using the smooth round object, apply light pressure to the cut or scratched surface rubbing it until it begins to heal.

NOTE: Spray the surface of the panels and doors with silicone to give them a like new bright and glossy appearance.



801 Corey Street • Scranton, PA 18505 • 800.445.5148 • Fax 855.376.6161 • info@scrantonproducts.com

www.scrantonproducts.com