

HONEYCOMB

OUTDOOR LIVING

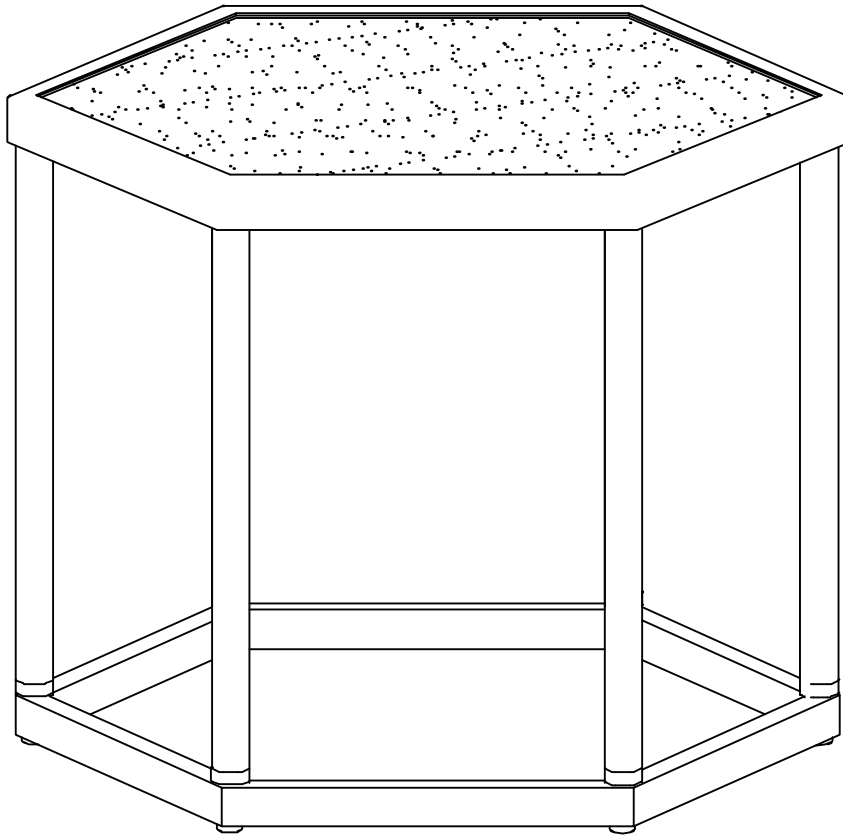

OMNI TABLE

PARTS

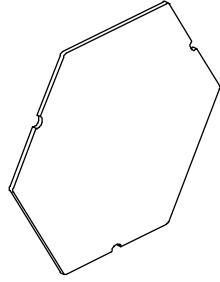

A

TILE

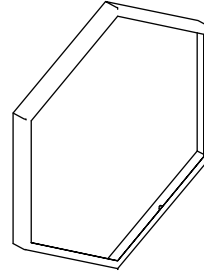

B

TABLETOP UPPER FRAME

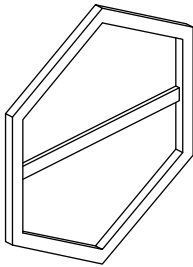

C

TABLE TOP LOWER FRAME

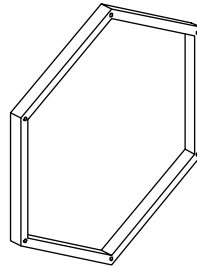

D

BASE

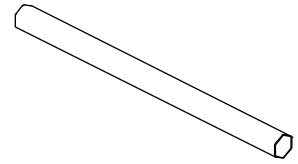

E

TABLE LEG

HARDWARE

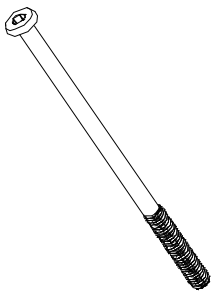

F

TABLE LEG BOLT

6 pcs



G

BOLT

3 pcs



H

TABLE LEG PAD

6 pcs

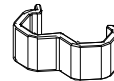

I

CONNECTOR CLAMP

1 pc



J

ALLEN KEY

1 pc

ASSEMBLY INSTRUCTIONS

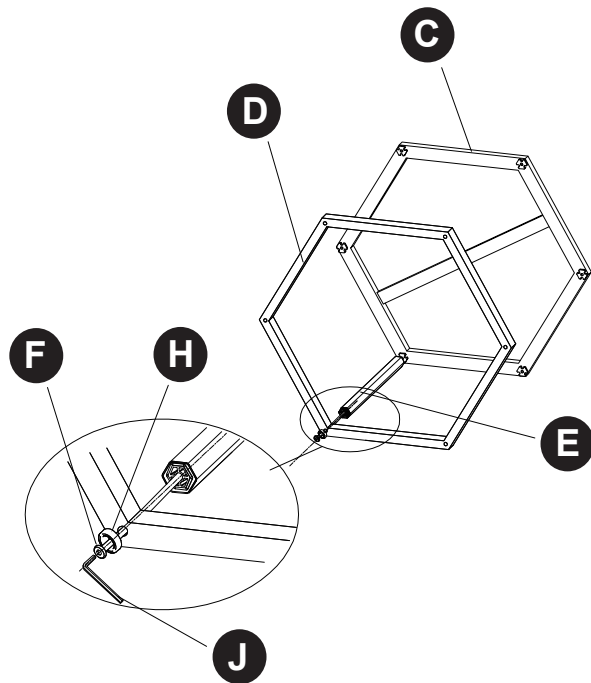

Table top lower frame (C) and base (D) are connected with six table legs (E).

They are secured with table leg bolts (F) using the allen key (J).

Note: Put table leg pads (H) on the table leg bolts (F) before assembly.

Also, do not tighten table leg bolts (F) until after all six legs are connected.

Note that the plastic parts in the table leg should face down.

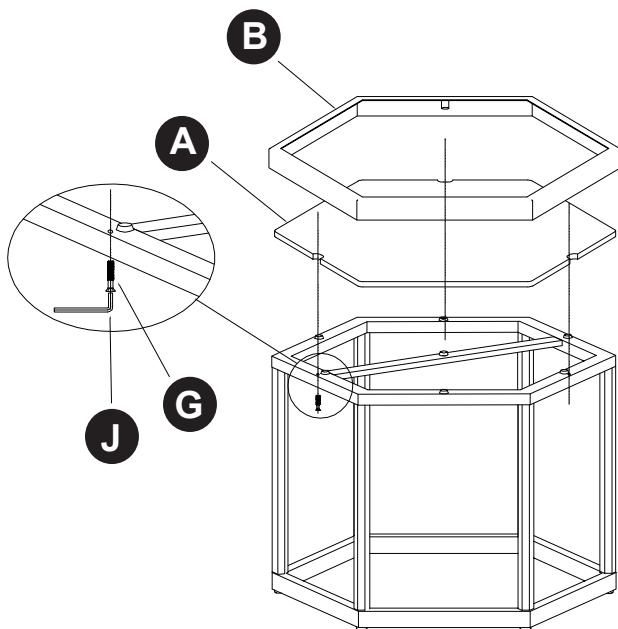

As shown in the picture, place tile (A) on the table frame, Align the tabletop upper frame (B) and lock it with bolts (G).

ASSEMBLY INSTRUCTIONS

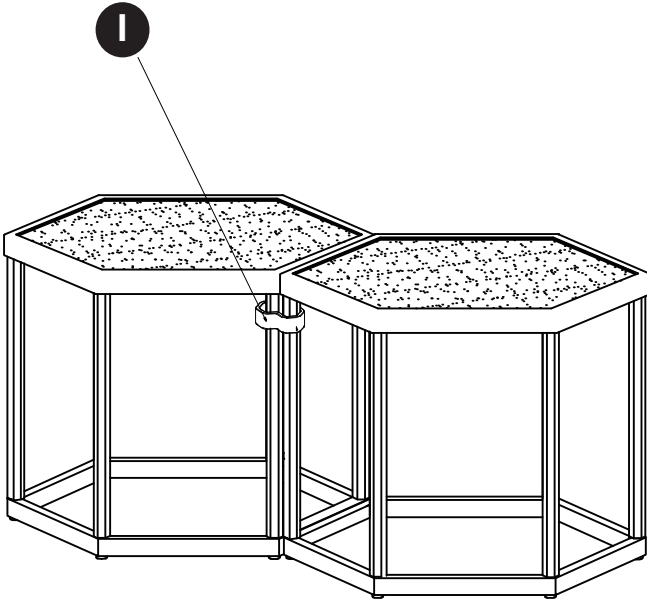

Interlock two or multiple tables together with a connector clamp (I).

Scan this QR code for more information

For any inquiries, kindly contact us at
hello@honeycomboutdoor.com

