

# HONEYCOMB

OUTDOOR LIVING

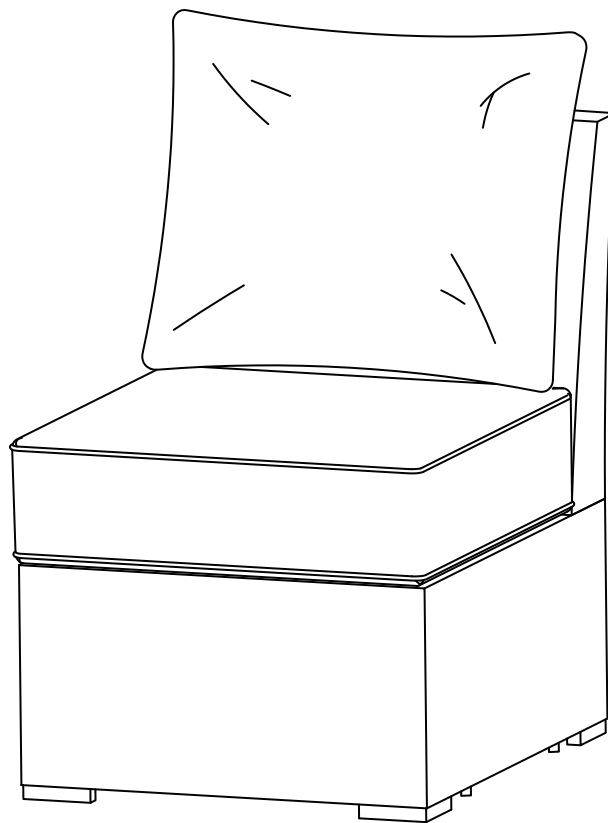

## CARMEL WICKER CHAIR

# PARTS

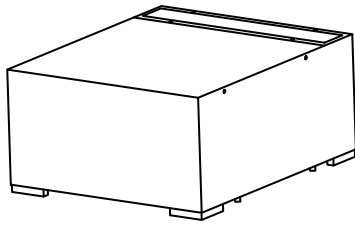

**A**

**CHAIR SEAT**

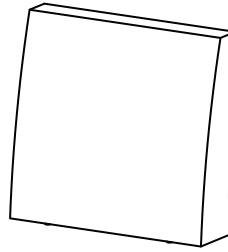

**B**

**CHAIR BACK**

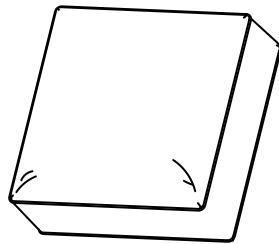

**C**

**SEAT CUSHION**

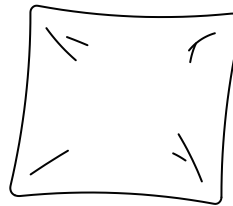

**D**

**BACK CUSHION**

# HARDWARE

**G**



**BOLT**

5/16" x 40mm  
4 pcs

**H**



**WASHER**

18 mm  
4 pcs

**I**



**ALLEN KEY**

1 pc

**J**



**LOCK WASHER**

16 x 2.5 mm  
4 pcs

# ASSEMBLY INSTRUCTIONS

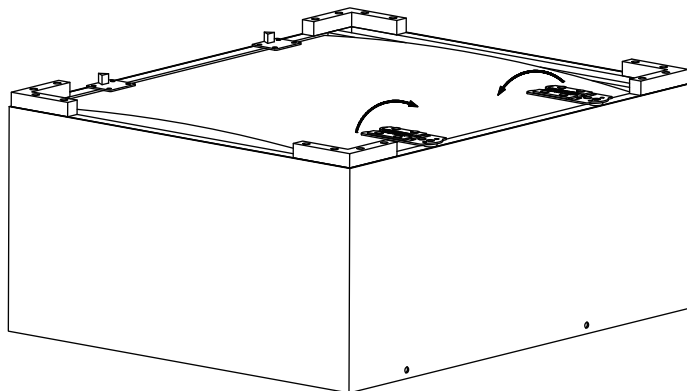

Turn the connectors  
180 degrees outward

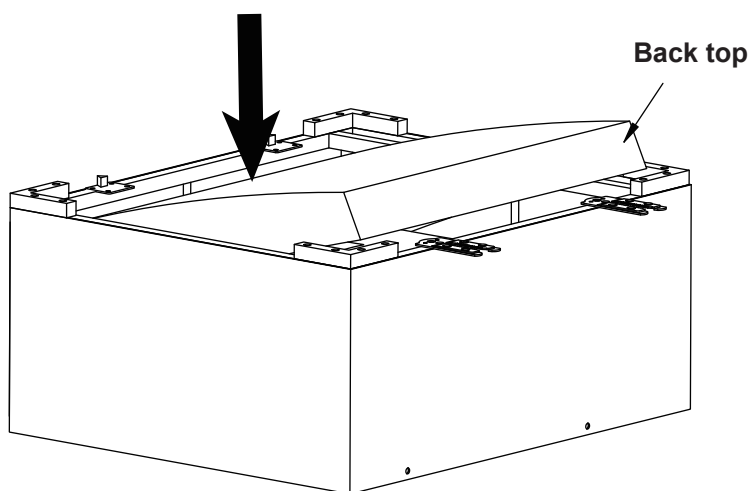

Press down on the front  
top of the chair back

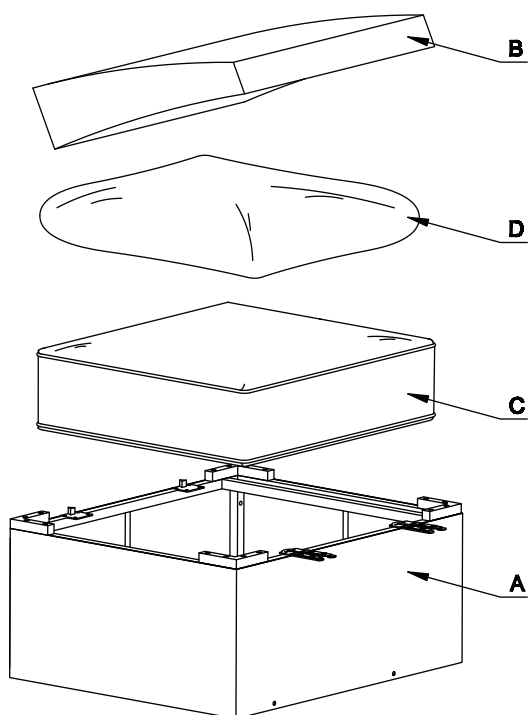

Take out the chair back (B),  
the back cushion (D) and  
the seat cushion (C) from the  
bottom of the seat (A)

# ASSEMBLY INSTRUCTIONS

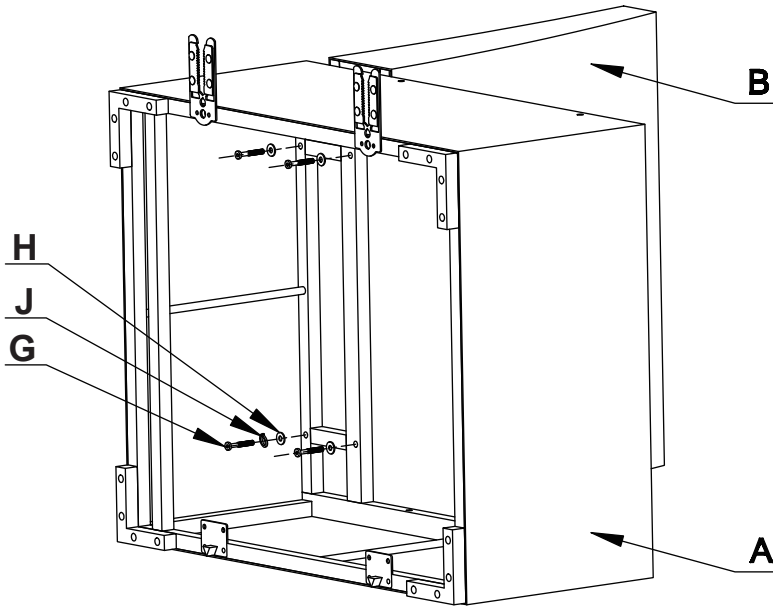

Insert back (B) into seat (A) and lay on its side. Attach the back (B) to the seat (A) using bolts (G), washers (H) and lock washers (J)

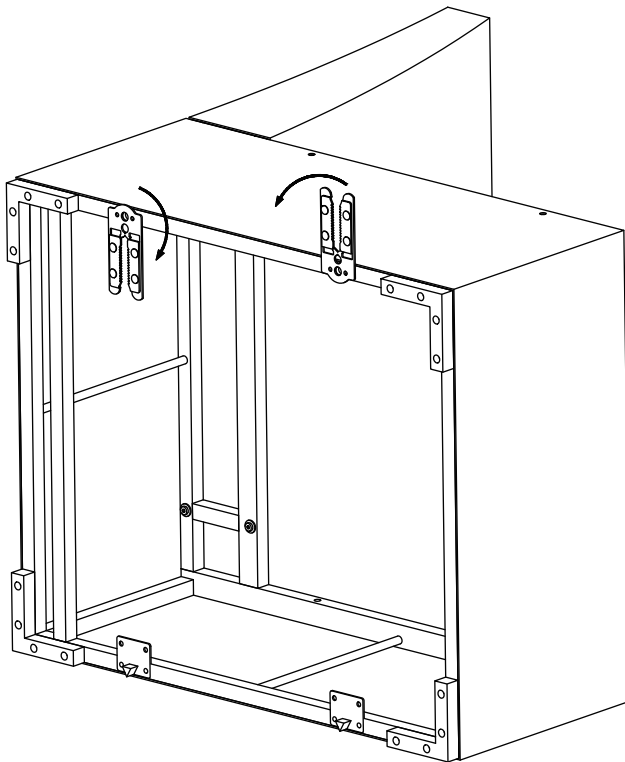

Tighten all bolts. Turn the connectors 180 degrees inward

# ASSEMBLY INSTRUCTIONS

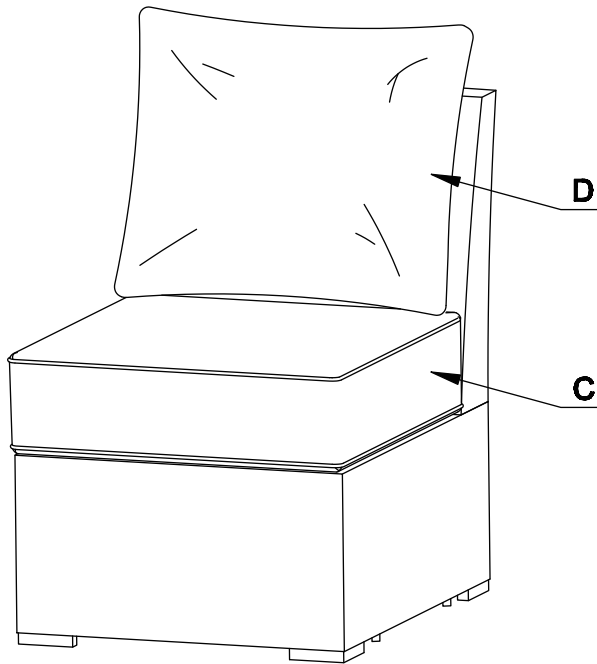

Add the seat cushion (C)  
and the back cushion (D)

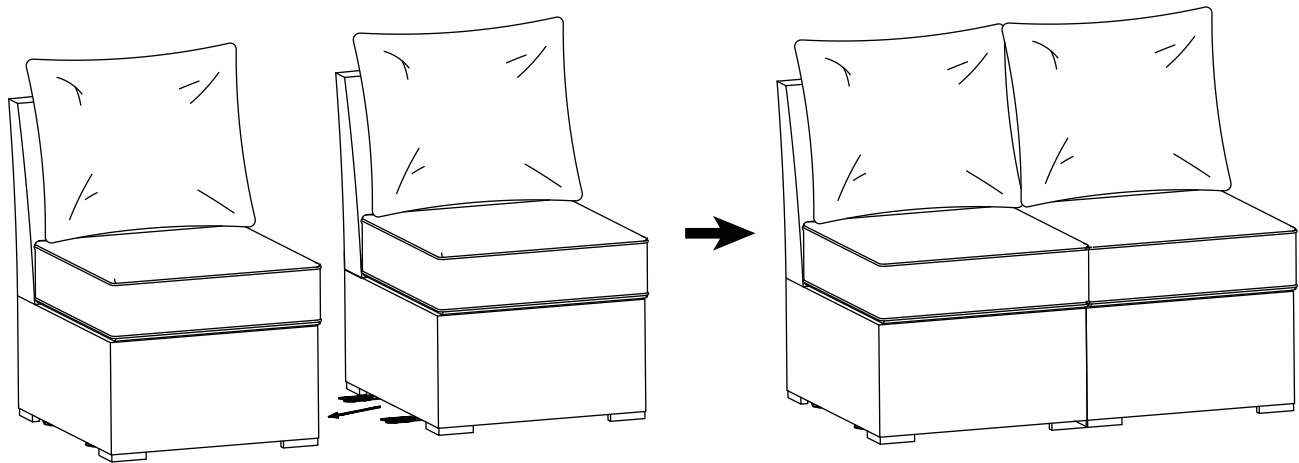

To assemble multiple chairs, turn the connectors outward and  
firmly insert into the other chair

Scan this QR code for more information

For any inquiries, kindly contact us at  
[hello@myhoneycomb.us](mailto:hello@myhoneycomb.us)



# STORAGE INSTRUCTIONS

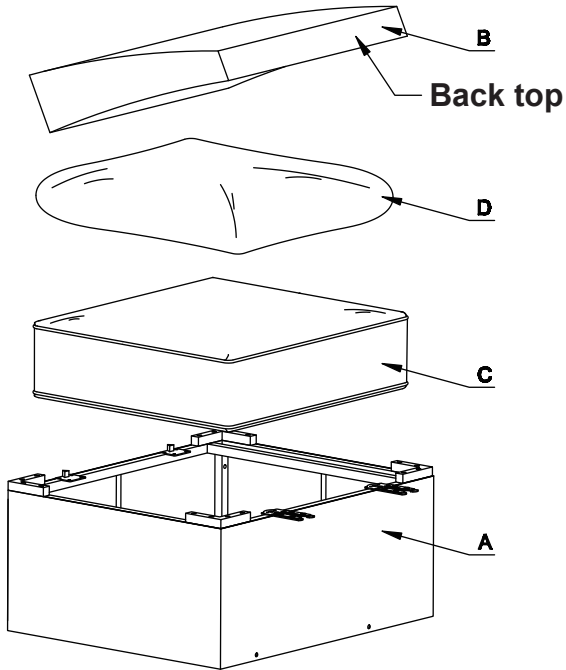

When not in use, put the seat cushion (C), the back cushion (D), and chair back (B) into the bottom of the seat (A)

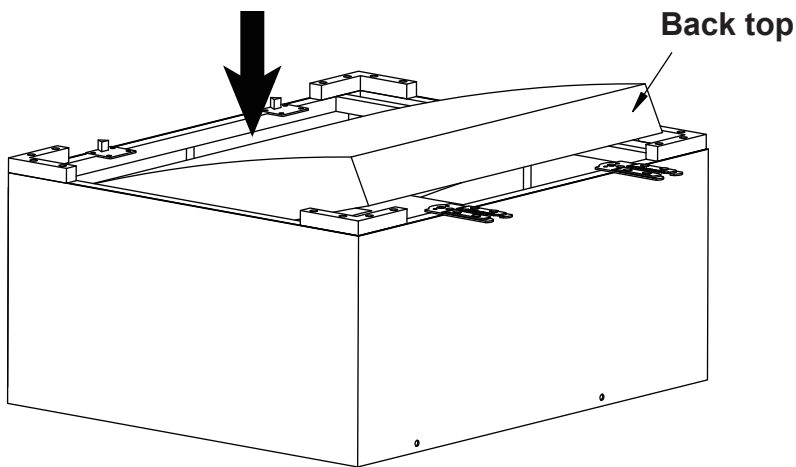

Press down on the front top of the chair back

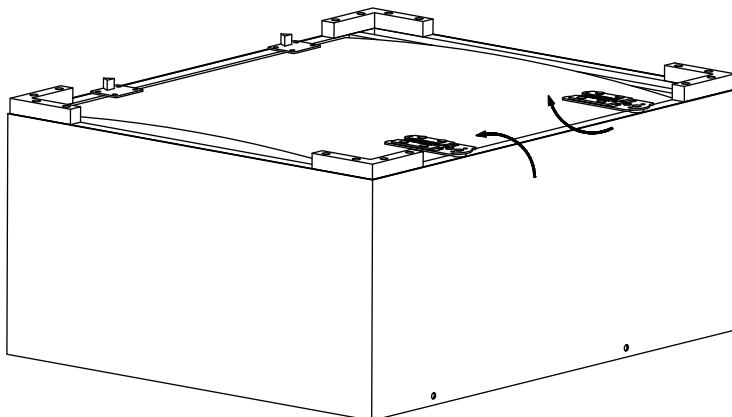

Turn the connectors 180 degrees inward