

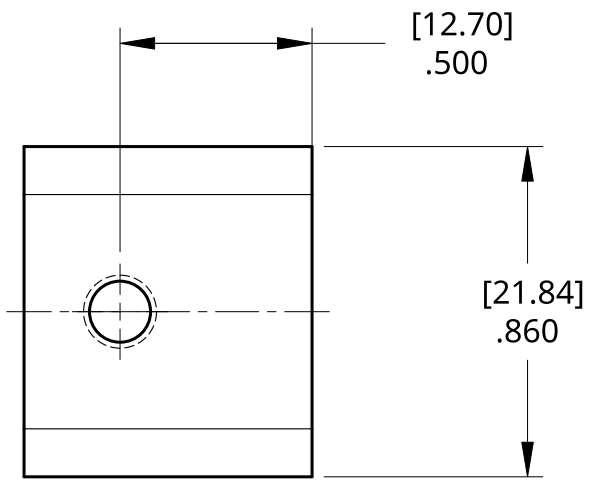

2

1

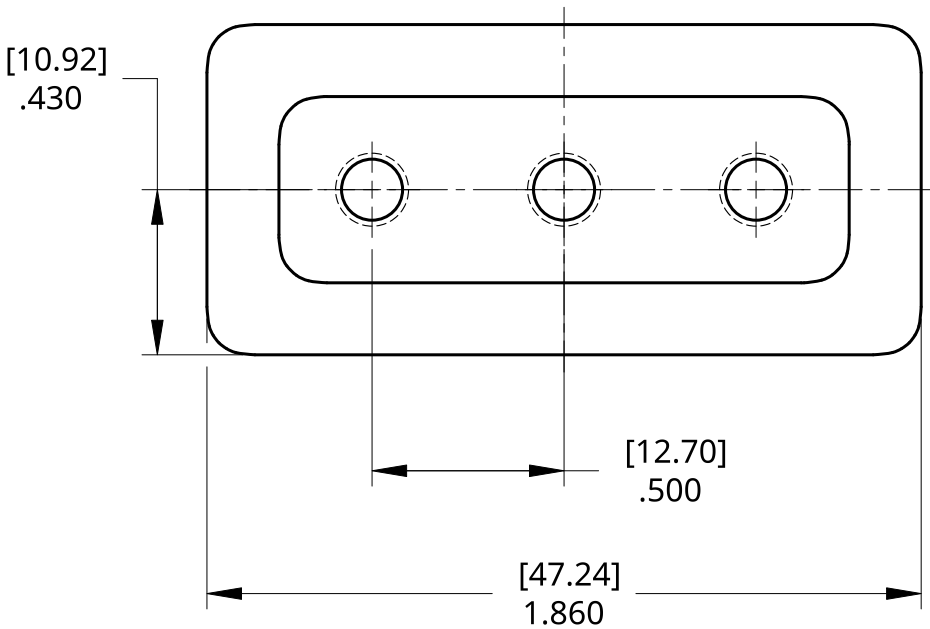
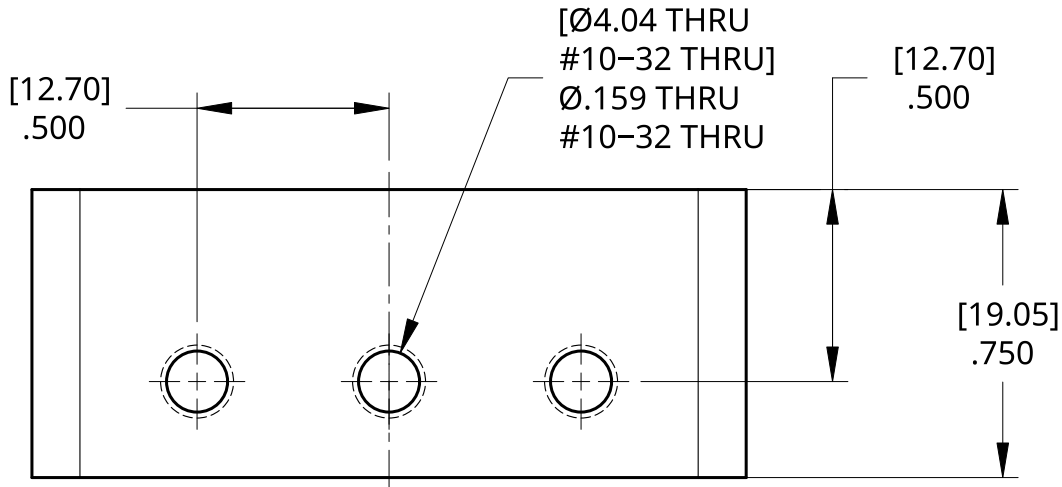

TITLE 2" x 1" for 0.0625"		Endcap		 LAST ANVIL INNOVATIONS
DATE	12/18/2023			
MATERIAL	6061-T6 Al	FINISH	Mill Finish	
SIZE	A			REV. 1
SCALE	2:1		DIMENSIONS ARE IN INCHES	SHEET 1 of 1

2

1

B

B

A

A