

OPERATION MANUAL

COLOR INKJET PRINTER
TS55-1800

OPERATION MANUAL

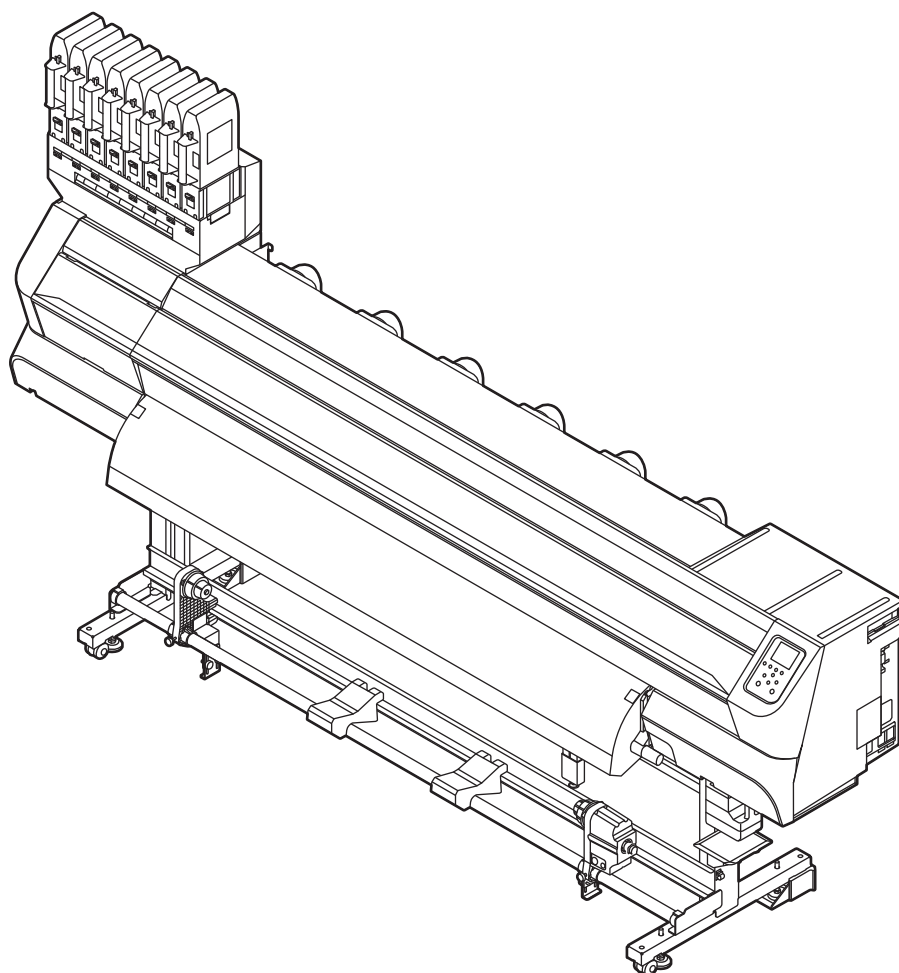

You can also download the latest manual from our website.

MIMAKI ENGINEERING CO., LTD.

<https://mimaki.com/>

D203290-22

Original instructions

TABLE OF CONTENTS

CAUTION	v
DISCLAIMER OF WARRANTY	v
Requests	v
FCC Statement (USA)	v
Interference to televisions and radios	v
Foreword	v
On This document	v
Safety Precautions	vi
Symbols	vi
Safety interlock	x
Warning labels	xi

Chapter 1 Before Use

Moving This Machine	1-2
Where to Install This Machine	1-2
Working Environmental Temperature.....	1-2
Moving This Machine	1-2
Names of Parts and Functions	1-4
Front Side of the Machine	1-4
Rear Side and Right Side of the Machine	1-5
Operation Panel	1-6
Media sensor.....	1-8
Carriage.....	1-8
Cutter blade and slot for cutting	1-8
Capping station	1-8
Pinch rollers and Feed rollers.....	1-8
Connecting Cables	1-9
Connecting the LAN cable.....	1-9
Connecting USB2.0 Interface Cable	1-10
Connecting the power cable.....	1-11
Setting Ink	1-11
Caution in handling of ink packs.....	1-15
Media	1-16
Usable sizes of media	1-16
Caution in handling of medias.....	1-16
Menu mode	1-17

Chapter 2 Basic Operations

Workflow	2-2
Turning the Power ON/OFF	2-3
Turning the Power ON.....	2-3

Turning the Power OFF	2-3
Setting a Media	2-4
Adjusting the Head Height.....	2-4
Setting a roll media.....	2-5
Take-up device.....	2-9
Changing the printing origin	2-10
Preparing for the Heaters	2-11
Changing the Temperature Settings for the Heaters.....	2-11
Test Printing	2-11
Test Printing	2-11
Head Cleaning	2-12
About head cleaning.....	2-12
Perform head cleaning depending on the test printing result	2-12
Setting of Media Correction	2-13
Setting of Media Correction.....	2-13
Setting of Media Correction (Print Condition Correction).....	2-13
If the Positions of Dots Shift... ..	2-14
Printing Data	2-14
Starting a Printing Operation	2-14
Stopping a Printing Operation	2-15
Deleting Received Data (Data Clear).....	2-15
Cutting a media	2-15

Chapter 3

Setup

About SETUP MENU	3-2
SETUP MENU table	3-2
Register the optimal print conditions to match the use.....	3-4
Setting of Media Correction.....	3-4
If the Positions of Dots Shift... ..	3-5
Setting the HEATER.....	3-6
Setting of Logical Seek.....	3-6
Setting of Overprint	3-6
Setting of Drying Time	3-7
Setting of Left and Right Margins	3-7
Printing Refresh.....	3-7
Setting of Vacuum Fan.....	3-8
Setting of Feed Speed.....	3-8
Setting Auto Cleaning.....	3-8
Setting External heater	3-9
Setting of MAPS4	3-9
Pass density correct	3-10
Setting Pre-feed	3-10
Change of setting type name	3-10
About MACHINE SETUP MENU	3-12
MACHINE SETUP MENU table	3-12
Setting a AUTO Power-off.....	3-15
Setting Take-up unit	3-15
Setting Top Blower	3-15
Setting the Display of Media Residual.....	3-15
Setting the Media Detection	3-16

Setting a LANGUAGE	3-16
Setting a Time	3-16
Setting Unit (Temperature/ Length).....	3-17
Setting a KEY BUZZER.....	3-17
Setting the VIEW FEED	3-17
Setting the space between prints	3-17
Setting the SPACE FEED MODE.....	3-17
Set the network	3-18
Setting event mail function	3-18
Automatic remote	3-22
Lighting.....	3-22
Feeding before cut	3-22
Initializing the Settings.....	3-22
About NOZZLE CHECK MENU	3-24
INFORMATION MENU table.....	3-24
Printing Check Flow	3-25
Printing Operations at "Nozzle Missing" Judgment and Error Occurrence	3-25
Setting the Printing Check.....	3-26
Setting the NOZZLE RECOVERY	3-26
Setting the Judgment Condition	3-26
About INFORMATION MENU	3-27
INFORMATION MENU table.....	3-27
Displaying the Information.....	3-28
Display maintenance status (local guidance).....	3-28

Chapter 4 Maintenance

Maintenance	4-2
Precautions for Maintenance.....	4-2
About Cleaning Solution	4-2
Cleaning the Exterior Surfaces.....	4-2
Cleaning the Platen.....	4-2
Cleaning the Media Sensor	4-3
Cleaning the Media Press	4-3
Wash the Blow down fan filter	4-3
Maintenance of Ink Pack.....	4-4
About MAINTENANCE MENU	4-5
MAINTENANCE MENUs table	4-6
Maintaining the Capping Station	4-7
Cleaning the Wiper.....	4-7
Cleaning the Cap.....	4-8
Cleaning the Cap Absorber	4-8
Nozzle cleaning	4-9
Cleaning the Ink Discharge Passage	4-10
When the Machine Is Not Used for a Long Time	4-10
Cleaning the Ink Head and the Area Around It	4-12
Nozzle Recovery Function	4-13
Reset the Set Value	4-14
Check Conditions for Which Nozzle Recovery Cannot be Performed	4-14
Set Whether to Enable NOZZLE RECOVERY During TEST PRINT	4-15

Auto Maintenance Function	4-15
Setting the Refreshing Intervals	4-15
Setting the Cleaning Intervals and Type	4-16
Replacing Consumables	4-16
Replacing the Wiper	4-16
Replacing the Wiper Cleaner	4-17
Replacing the Cap	4-18
Replacing the Cap Absorber	4-18
Replacing the Media Press	4-19
Replacing the Pinch roller	4-20
Replacing the Spout Rubber	4-21
Replacing the Carriage filter	4-23
Male Connector Absorbent for MBIS	4-23
Replacing the Blow down fan filter	4-24
Replacing the Cutter Blade	4-24
Media edge guide film replacement	4-25
Waste ink tank management	4-26
Correction of waste ink amount	4-26
Change of tank capacity	4-26
If a Waste Ink Tank Confirmation Message Appears	4-26
Replace the waste ink tank with another	4-26

Chapter 5

Troubleshooting

Troubleshooting	5-2
Power does not turn on	5-2
The machine does not start printing	5-2
Media get jammed / media is soiled	5-2
The heater's temperature will not rise to the set level	5-3
Image quality is poor	5-3
Nozzle is clogged	5-3
If an abnormality occurs in the state of the ink	5-3
When the ink leakage occurs	5-4
Warning / Error Messages	5-5
Warning messages	5-5
Error message	5-11

Chapter 6

Appendix

Specifications	6-2
Machine specifications	6-2
Ink specifications	6-3
Setting orders depending on ink type	6-4
Setting orders of ink cartridges	6-4
Sheet for inquiry	6-5
LICENSE Library	6-6

CAUTION

DISCLAIMER OF WARRANTY

THIS LIMITED WARRANTY OF MIMAKI SHALL BE THE SOLE AND EXCLUSIVE WARRANTY AND IS IN LIEU OF ALL OTHER WARRANTIES, EXPRESS OR IMPLIED, INCLUDING, BUT NOT LIMITED TO, ANY IMPLIED WARRANTY OF MERCHANTABILITY OR FITNESS, AND MIMAKI NEITHER ASSUMES NOR AUTHORIZES DEALER TO ASSUME FOR IT ANY OTHER OBLIGATION OR LIABILITY OR MAKE ANY OTHER WARRANTY OR MAKE ANY OTHER WARRANTY IN CONNECTION WITH ANY PRODUCT WITHOUT MIMAKI'S PRIOR WRITTEN CONSENT.

IN NO EVENT SHALL MIMAKI BE LIABLE FOR SPECIAL, INCIDENTAL OR CONSEQUENTIAL DAMAGES OR FOR LOSS OF PROFITS OF DEALER OR CUSTOMERS OF ANY PRODUCT.

Requests

- This document has been carefully prepared for your easy understanding.
However, please do not hesitate to contact a distributor in your district or our office if you have any inquiry.
- Description contained in this document are subject to change without notice for improvement.

FCC Statement (USA)

This equipment has been tested and found to comply with the limits for a Class A digital device, pursuant to Part 15 of the FCC Rules. These limits are designed to provide reasonable protection against harmful interference when the equipment is operated in a commercial environment. This equipment generates, uses and can radiate radio frequency energy and, if not installed and used in accordance with the Operation manual, may cause harmful interference to radio communications.

Operation of this equipment in a residential area is likely to cause harmful interference in which case the user will be required to correct the interference at his own expense.

In the case where MIMAKI-recommended cable is not used for connection of this device, limits provided by FCC rules can be exceeded.

To prevent this, use of MIMAKI-recommended cable is essential for the connection of this printer.

Interference to televisions and radios

The machine described in this manual generates high frequency when operating.

The machine can interfere with radios and televisions if set up or commissioned under improper conditions.

The machine is not guaranteed against any damage to specific-purpose radio and televisions.

The machine's interference with your radio or television will be checked by turning on/off the power switch of the machine.

In the event that the machine is the cause of interference, try to eliminate it by taking one of the following corrective measures or taking some of them in combination.

- Change the orientation of the antenna of the television set or radio to find a position without reception difficulty.
- Separate the television set or radio from this machine.
- Plug the power cord of this machine into an outlet which is isolated from power circuits connected to the television set or radio.

Foreword

Congratulations on your purchase of MIMAKI color ink jet printer "TS55-1800".

"TS55-1800" is a color inkjet printer that can print on 1.8m-width media with sublimation dye ink (4-color, 6-color, 7-color and 8-color).

On This document

- This document is describing the operations and maintenance of "Color inkjet printer TS55-1800" (called as this machine hereafter)
- Read this document carefully and understand them thoroughly to use.
- It is also necessary to keep this document on hand.
- This document has been carefully prepared for your easy understanding, however, please do not hesitate to contact a distributor in your district or our office if you have any inquiry.
- Descriptions contained in this document are subject to change without any notice for improvement.
- In the case when this document should be illegible due to burning or damage, purchase another copy from our sales office.
- You can also download the latest manual from our website.









Reproduction of this manual is strictly prohibited.
All Rights Reserved. Copyright
© 2018 MIMAKI ENGINEERING Co., Ltd.

Safety Precautions

Symbols

In this document, symbols are used for explaining the contents of cautions on operation. The symbol to be displayed differs depending on the caution content.

Please understand the meaning of each symbol and use this machine safely and correctly.

Symbol	Name	Explanation
	Warning	Warning Indicates a potentially hazardous situation, which, if not handled correctly by ignoring the instructions, may result in death or serious injury. Be sure to read it carefully and use it properly.
	Caution	Indicates a potentially hazardous situation, which, if not handled correctly by ignoring the instructions, may result in minor injury or moderately serious injury.
	Notice	Indicates a potentially hazardous situation, which, if not handled correctly by ignoring the instructions, may result in damage to property.
	General warning sign	Indicates a matter requiring attention. Specific notes are drawn in the figure.
	General mandatory action sign	Indicates an action that must be carried out. Specific instructions are drawn in the figure.
	General prohibition sign	Indicates a prohibited action. Specific prohibited contents are drawn in the figure.
	Tips	Indicates reference information.
	Reference information	Indicates the page to be referred to for related information. Click the text to display the corresponding page.

Warning for Use

Warning



- The set of power cables provided with this machine is for use with this machine only, and cannot be used with other electrical devices. Do not use any power cables other than the ones provided with the machine. Failure to observe those instructions may result in fire or electric shocks.
- Take care not to damage, break or work upon the power cable. If a heavy material is placed on the power cable, or if it is heated or pulled, the power cable can break, thus resulting in fire or electric shocks.
- Do not use this machine in an environment where humidity is high or the machine may get wet. Using the machine under such environment may result in fire or electric shock, or cause malfunction.
- Use of the machine under an abnormal condition where it produces smoke or strange smell can result in fire or electric shocks. If such an abnormality is found, be sure to turn off the power switch immediately and unplug the cable from the wall outlet. Check first that the machine no longer produces smoke, and then contact your distributor or a sales office of MIMAKI for repair.
Never repair your machine by yourself since it is very dangerous for you to do so.
- Never disassemble or remodel the main unit of the machine or the ink cartridge. Disassembly or remodeling can result in an electric shock or breakdown of the machine.
- Take care that no dust or dirt sticks to Media Transfer Surface heaters. Dust and dirt sticking heaters can cause fire.
- Do not use extension cords. Doing so may result in fire or electric shocks.
- Keep the power plug prong clear of any foreign object such as a piece of metal. Failure to do so may result in a fire or electric shocks.
- Do not plug too many leads into a single socket. Doing so may result in fire or electric shocks.
- Do not use the machine if the power cord or plug is damaged. Using the machine with damaged power cord may result in fire or electric shocks. Contact your service representative for replacement cord.
- Do not handle the power plug with wet hands. Doing so may result in electric shocks.
- Grasp by holding the plug itself when removing the power plug from wall outlet, and never hold by the cord. Holding and pulling the cord may damage the cord, leading to fire or electric shocks.
- Do not use the machine with the voltage other than the indicated one. Otherwise, it causes a fire and the electric shock.
- Do not use the device at a power supply frequency other than the one indicated. Doing so may result in fire or electric shocks.
- Keep Fingers and other parts of the Body Away from Hazardous Moving Parts.



Warning



- In case of ink leakage, please turn off the main power, unplug the power cable and contact your local distributor, our sales office, or service center.
- If a foreign object such as a small piece of metal or a liquid such as water gets inside the machine, turn off the machine and unplug the power cord immediately, then consult your service representative. Continuing to use the machine without proper maintenance or repair may result in fire or electric shocks.
- To move the equipment, contact the nearest service shop.
- Do not use flammable sprays or flammable solvents near or inside the unit. It may cause fire or electric shock.
- Do not put a vase, flowerpot, glass, cosmetics, medicine, container which water was in, or small metal thing in the top and near this option. When some spills over or enters inside of this option, it could cause a fire or electric shocks.
- Keep children away from this machine.

Precautions in Use



Caution

Power supply



- Leave the breaker turned ON.
- Do not turn off the main power switch on the right side of this machine.

Handling of the power cable



- Connect to a socket-outlet with determinate polarity.
- For PLUGGABLE EQUIPMENT, the socket-outlet shall be installed near the equipment and shall be easily accessible.
- Unplug the cord from the wall outlet and remove dust from the power plug periodically, at least once a year. Failure to do so may result in fire or electric shocks.
- Do not use the machine unless it is connected to a power supply that satisfies the displayed voltage condition.
- Check the voltage of the wall outlet and the capacity of the circuit breaker before you plug the power cords. Plug each power cord to different outlet that has independent circuit breaker. If you plug more than one power cord to wall outlets that share the same circuit breaker, the power may be cut off by the breaker.

Heater



- Do not spill liquid on the Media Transfer Surface as this may cause failure of the heater or firing.
- Do not touch Media Transfer Surface heaters with bare hand while it is hot; otherwise, you can get burned.

**Caution****Note on maintenance**

• When handling ink and cleaning solution, pay close attention to ventilation and be sure to wear the included safety glasses and gloves.



• Pay close attention to ventilation and be sure to wear the included safety glasses and gloves.

• The gloves supplied with the machine are disposable. When all the gloves are expended, purchase an equivalent product on the market.



• Do not touch the sharp edge of the blade when replacing the cutter. Touching the sharp edge may result in injury.

Notes When Handling this machine

- Use the equipment in a well-ventilated or not-airtight room.
- Ventilate the room sufficiently before using the equipment.
- Do not place the equipment in a humid or dusty place. Otherwise, there is a risk of fire or electrical shock.
- Do not place the equipment in an unstable place such as on a shaky table and on a tilted surface. The equipment may fall over or drop and cause injury.
- The equipment is provided with a built-in media cutter. To replace or feed a printing medium, or to remove a jammed printing medium, do not touch any area other than those specified in this document. Otherwise, there is a risk of injury.
- To replace a printing media, be careful not to pinch your fingers or get injured.
- Consult with the service shop about cleaning inside the equipment.
Leaving the equipment with dust inside without cleaning for a long time may cause a fire or device failure. Consult with the distributor or service shop for the cost of cleaning inside the equipment.

**Caution****Handling of ink packs**

- Keep ink away from an open flame. Also keep the room well ventilated when you use or handle ink.
- If you get ink in your eyes, immediately wash your eyes with a lot of clean water for at least 15 minutes. In doing so, also wash eyes to rinse ink away completely. Then, consult a doctor as soon as possible.
- Before using ink and cleaning solution, be sure to read the Safety Data Sheet (SDS).
- If anyone drinks ink by mistake, keep him or her quiet and see a doctor immediately. Do not allow him or her to swallow the vomit. Then contact the emergency number written in SDS.
- If you inhale a great deal of vapor and feel ill, immediately move to a location with plenty of fresh air, and keep yourself warm and quiet. Consult a doctor as soon as possible.
- Store ink packs in a place that is out of the reach of children.
- If the ink adheres to your skin, use a large amount of water and soap or special detergent for skin to remove the ink.
- Do not leave the ink slot empty for a long time. Leaving it empty may dry the slot and solidify the ink in the machine, then the machine will become unable to supply ink.
- If ink packs are not set in the ink slot, an error message will display on the printer to set ink packs. Set the same colored ink cartridge as the ink used before.
- When you removed the ink pack from the seat before it ends, wipe ink adhering to inside of the connector part of the ink pack with a cotton swab etc. If ink adhering to inside of the connector part may dry out, it may cause ink leakage when using it again.

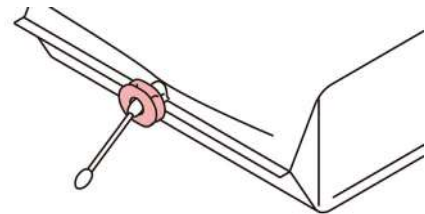

- There are precautionary notes on ink on the ink packs. Read it carefully and fully understand it before using it.
- When removing eco case from the seat, be sure to wear safety glasses etc. Ink may spatter and get in your eyes. Do not pull out and insert the middle cartridge again as much as possible.



CAUTIONS and NOTES

Warning

Handling of ink packs

- The safety evaluation of this machine assumes that the ink recommended by this company is used. For safe usage of this machine, use the ink recommended by this company
- Never refill the ink pack with ink. Refilled ink pack can cause a trouble. Remember that MIMAKI assumes no responsibility for any damage caused by the use of the ink pack replenished with ink.
- If the ink pack is moved from a cold place to a warm place, leave it in the room temperature for three hours or more before using it.
- Open the ink pack just before installing it in the machine. If it is opened and left for an extended period of time, normal printing performance of the machine may not be ensured.
- Make sure to store ink packs in a cool and dark place.
- Store ink packs and waste ink bottle in a place that is out of the reach of children.
- Be sure to thoroughly consume the ink in the ink pack, once it is opened, within one month. If an extended period of time has passed away after opening the cartridge tank, printing quality would be poor.
- Neither pound the cartridge nor shake it violently, as doing so can cause leakage of ink.
- Consult your sales or service representative for proper disposal of ink pack, ink pack, and waste ink. When you dispose them by yourself, follow the regulations stipulated by the industrial waste disposer or the country or region you live in.

Handling of media

- Use media recommended by MIMAKI to ensure reliable, high-quality printing.
- Set the heater temperature to meet the characteristics of the media. (Model with a built-in heater)
Set the temperature of the Post-heater according to the type and characteristics of the media used. Automatic temperature setting can be made on the operation panel by setting the profile on the dedicated RIP. For setting on the RIP, refer to the instruction manual for your RIP.
- Pay attention to the expansion and contraction of the media.
Do not use media immediately after unpacking. The media can be affected by the room temperature and humidity, and thus it may expand and contract. The media have to be left in the atmosphere in which they are to be used for 30 minutes or more after unpacked.
- Do not use curled media.
The use of curled media can not only cause a media jam but also affect print quality. Straighten the sheet of media, if significantly curled, before using it for printing. If a regular-sized coated sheet of media is rolled and stored, the coated side has to face outside.
- Do not leave the media with the heater ON for a long time.

Warning

Protection of media from dust

- Store media in a bag. Wiping off dust accumulated on media will adversely affect the media due to static electricity.
- When leaving the workshop after the working hours, do not leave any media on the roll hanger. If any media is left on the roll hanger, it can get dusty.

Periodic replacement parts

- Some parts of this machine must be replaced with a new one periodically by service personnel. Be sure to make a contract with your distributor or dealer for After sale service to ensure a long life of your machine.





Disposition of this machine

- Consult your sales or service representative for proper disposal of this machine. Otherwise, commission an industrial waste disposal company.

Notes on maintenance

- It is strongly recommended to use the machine in a room that is not dusty.
- Keep the front cover closed even when the machine is not printing. If not, dust can accumulate on the nozzles in the heads.
- Dust in the heads can also cause drops of ink to fall suddenly down on the media during printing. In such a case, be sure to clean up the heads.
- When cleaning the ink-station or the heads, be sure to wear the included safety glasses and gloves.
- Perform wiping (removal of dust and paper powder) of the capping station and wiper frequently.

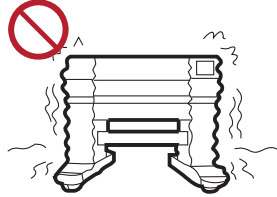
Cautions on Installation

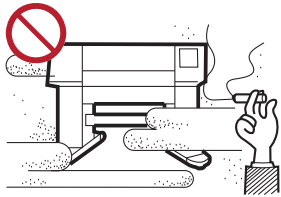
 Caution	
<p>A place exposed to direct sunlight</p>	<p>On an inclined surface</p>
	
<p>A place that vibrates</p>	<p>A place exposed to direct air flow from an air conditioner or the like.</p>
	
<p>A place where temperature or humidity varies significantly</p>	<p>Around a place where fire is used</p>
<p> Use the machine under the following environmental conditions:</p> <ul style="list-style-type: none"> • Operating environment: 20 to 30 °C (68 to 86 °F) 35 to 65 % (Rh) 	

Safety interlock



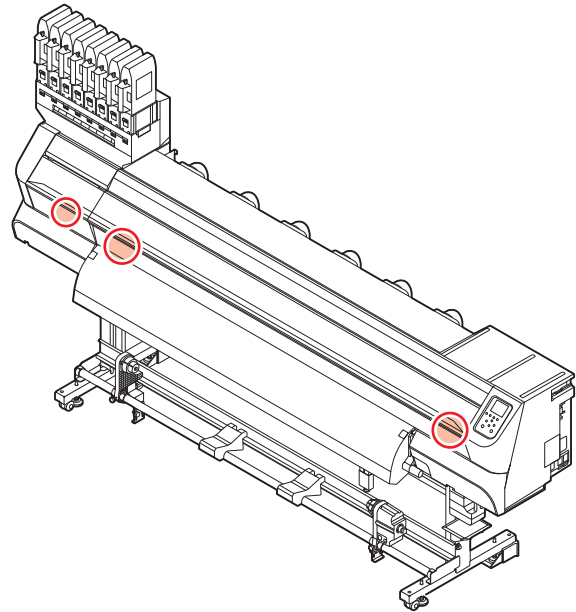



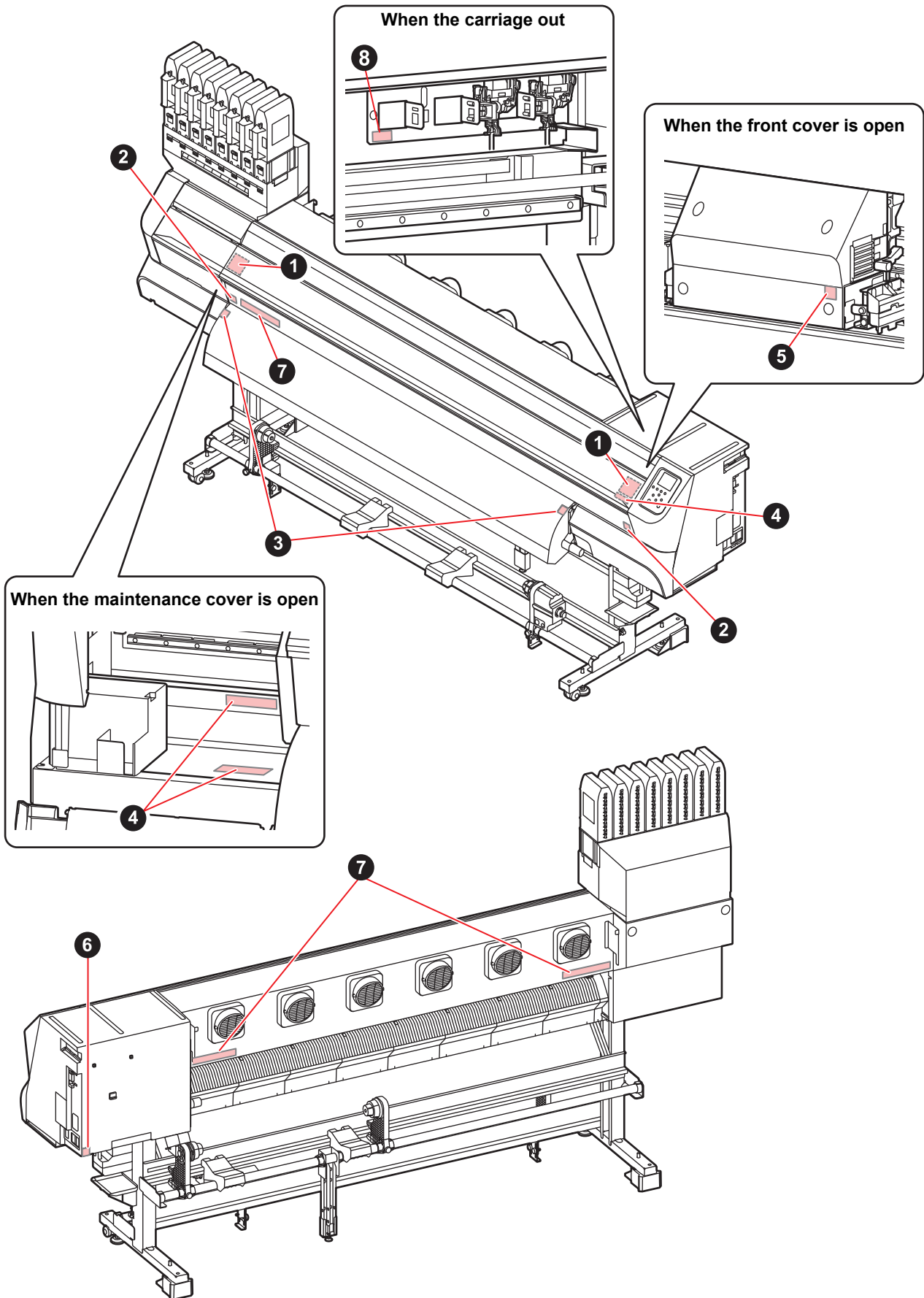

This machine is equipped with interlocks to terminate the operation for your safety when the cover opens during printing etc. (red circle parts in the figure below).



Warning labels

Warning labels are stuck on the machine. Be sure to fully understand the warning given on the labels. If a warning label is illegible due to stains or has come off, purchase a new one from a distributor or our sales office.



No.	Reorder	Label	Description
1	M910931		<p>There is a possibility that the cover falls suddenly. When opening or closing the cover, keep away your body from the both ends of the cover.</p>
2	M907833		<p>It is the carriage moving part. Do not bring your fingers and body close.</p>
3	M903239		<p>It is a hot surface. Do not touch the heater section.</p>
4	M903330		<p>When handling inks, be sure to wear the supplied safety glasses and gloves.</p>
5	M903405		<p>Media cut moving part. Do not bring your fingers and body close.</p>
6	M907935		<p>Dangerous voltage inside.</p>
7	M905811		<p>Moving part. Do not bring your fingers and body close.</p>
8	M906144		<p>High temperature part. Do not touch parts.</p>

Chapter 1

Before Use



This chapter

describes the items required to understand before use, such as the name of each part of the machine or the installation procedures.

Moving This Machine	1-2	Connecting Cables	1-9
Where to Install This Machine	1-2	Connecting the LAN cable	1-9
Working Environmental Temperature	1-2	Connecting USB2.0 Interface Cable	1-10
Moving This Machine	1-2	Connecting the power cable	1-11
Names of Parts and Functions.....	1-4	Setting Ink	1-11
Front Side of the Machine	1-4	Caution in handling of ink packs	1-15
Rear Side and Right Side of the Machine ...	1-5	Media	1-16
Operation Panel	1-6	Usable sizes of media	1-16
Media sensor	1-8	Caution in handling of medias	1-16
Carriage	1-8	Menu mode	1-17
Cutter blade and slot for cutting	1-8		
Capping station	1-8		
Pinch rollers and Feed rollers	1-8		

Moving This Machine

Where to Install This Machine

Secure a suitable installation space before assembling this machine.

The place of installation must have enough space for not only this machine itself, but also for the printing operation.

Model	Width	Depth	Height	Gross weight
TS55-1800	3240mm (127.6 in)	713mm (28.1 in)	1,857 mm (73.1 in)	202 kg (445.3 lb)

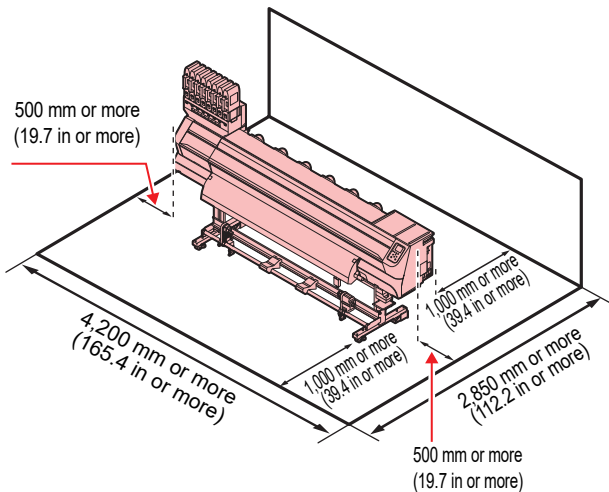

Working Environmental Temperature

Use this machine in an environment of 20 to 30°C (68 to 86°F) to ensure reliable printing.

Moving This Machine

Move this machine according to the following steps when this machine needs to be moved on the same step-free floor.



- When the machine is moved to any place other than on the same step-free floor, contact your distributor or our service office. If you move it by yourself, failure or damage may occur. Be sure to request your distributor or our service office to move this machine.



- When moving this machine, take care that it does not receive a significant impact.
- Be sure to lock the casters after moving of this machine.

1

Remove the caster block of the rear leg.

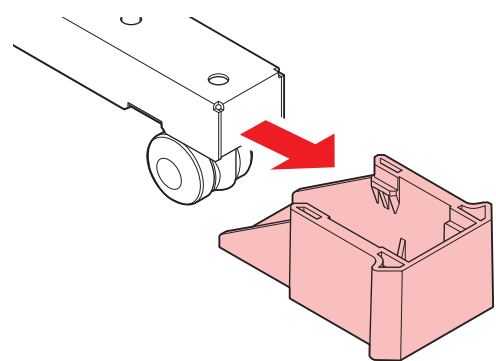

2

Raise the adjuster foot of the front leg with the attached adjustable angle wrench.

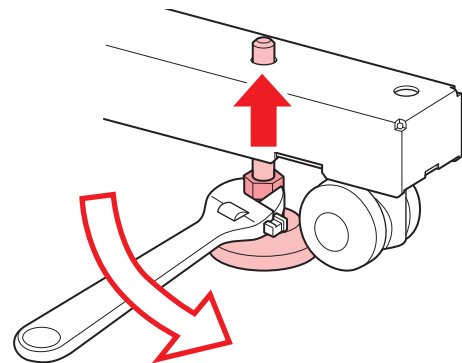

3

Raise the take-up legs.

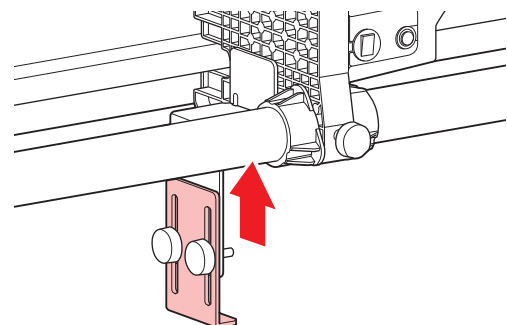

- 4** Raise the adjuster foot of the roll guide stay.

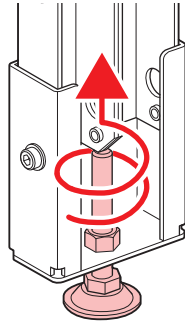

- 5** Move this machine as shown in the figure.

- For safety, be sure to operate it with 6 people or more.
- Do not push the cover to move this machine since the cover may be broken.

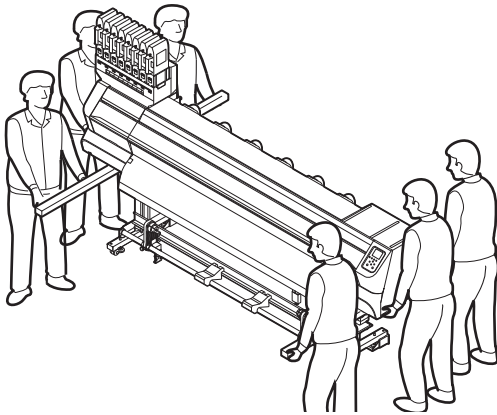

- 6** Lower the adjuster foot of the roll guide stay.

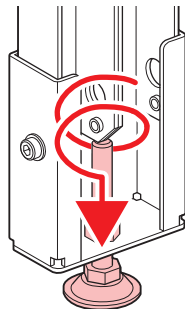

- 7** Lower the take-up legs.

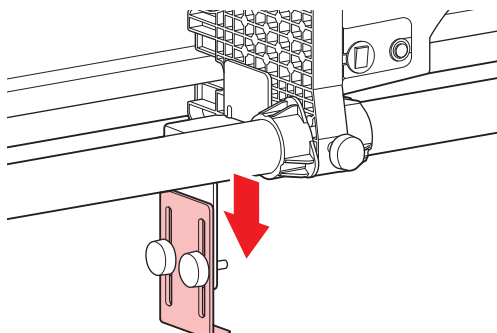

- 8** Lower the front leg adjuster foot with the attached adjustable angle wrench.

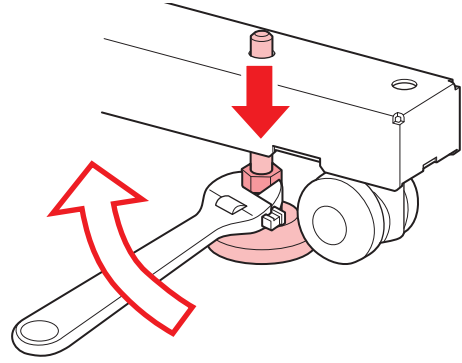

- When the installation floor is a soft material such as carpet, please use the attached base plate.

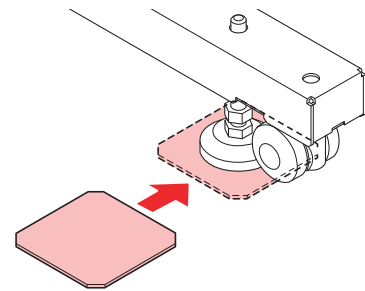

- 9** Attach the caster block to the rear leg.

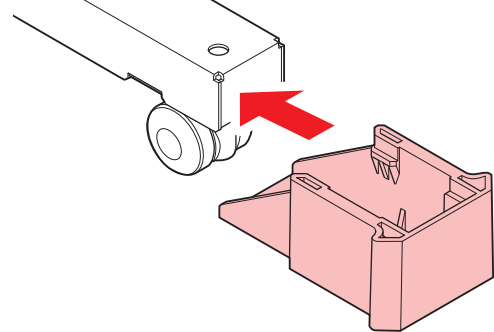

Names of Parts and Functions

Front Side of the Machine

Maintenance cover (upper)

Open the cover in maintenance.
Even when the power switch is off, keep all covers closed.

Ink cartridges

Each cartridge contains an ink of a particular color.

Heater

Fix and dry the printed ink.

Front cover

Open the cover in setting of medias, taking of measures against jamming of medias or in maintenance inside the station.
Even when the power switch is off, keep this cover and the other covers closed.

Clamp lever (front)

Moves the pinch rollers up and down to hold or release the media.

Carriage

Move the print head unit from side to side.

Operation panel

This panel has the operation keys required for operating the machine and the LCDs for displaying setting items, etc.

CleaningSolutionCartridge slot

Insert the cleaning solution cartridge.

Waste ink tank

Waste ink gathers in this tank.

Stand

Supports the main body of the machine. It is provided with casters that are used to move this machine.

Take-up device

Automatically winds up the roll media printed.

Media Edge Guide

Prevents lateral deviation of the roll media edges during media taking-up.
(left and right)

Roll rests

Rests for placing the roll on when installing roll media.

Maintenance cover (lower)

Open the cover in maintenance.
Even when the power switch is off, keep all covers closed.

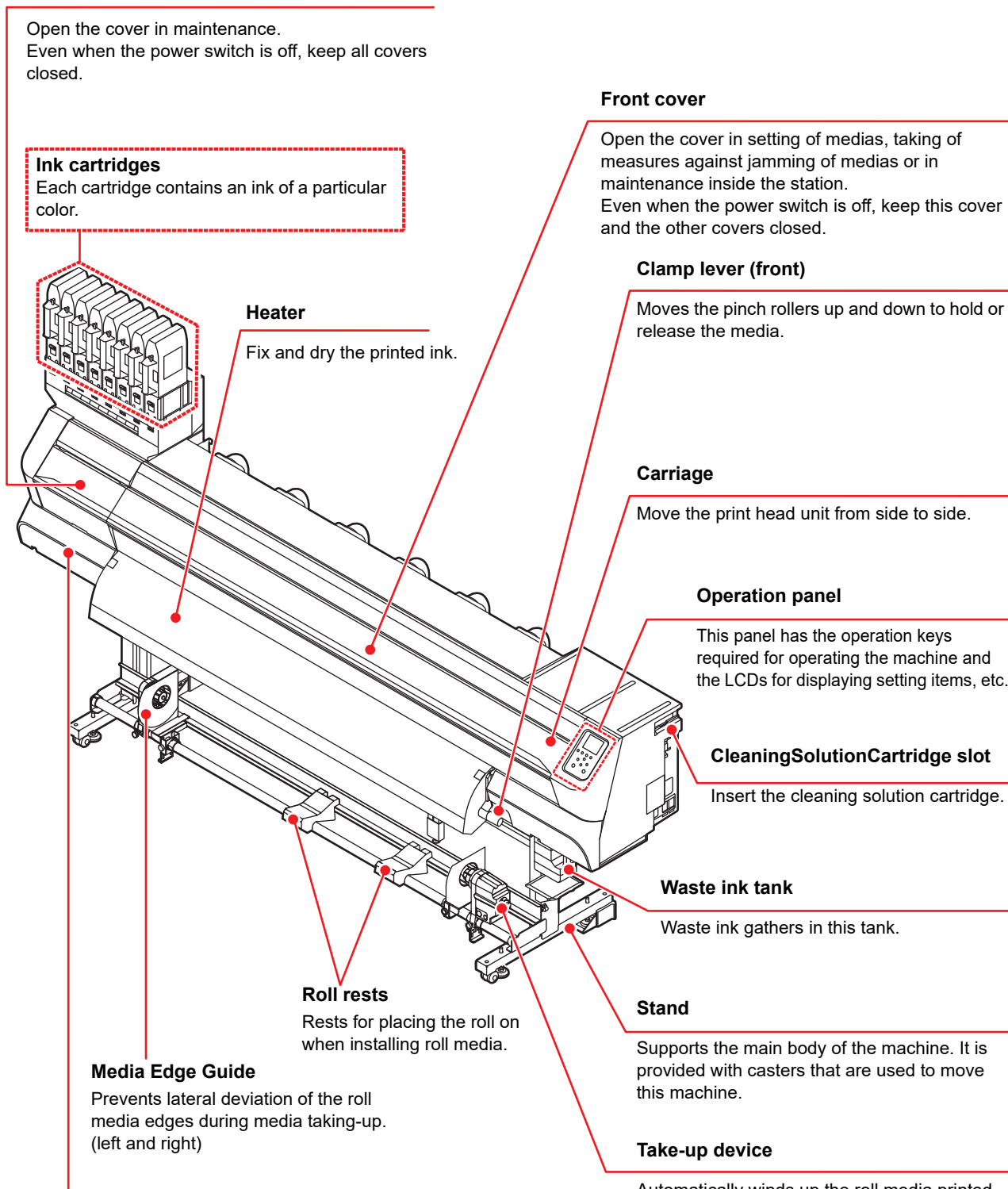

Rear Side and Right Side of the Machine

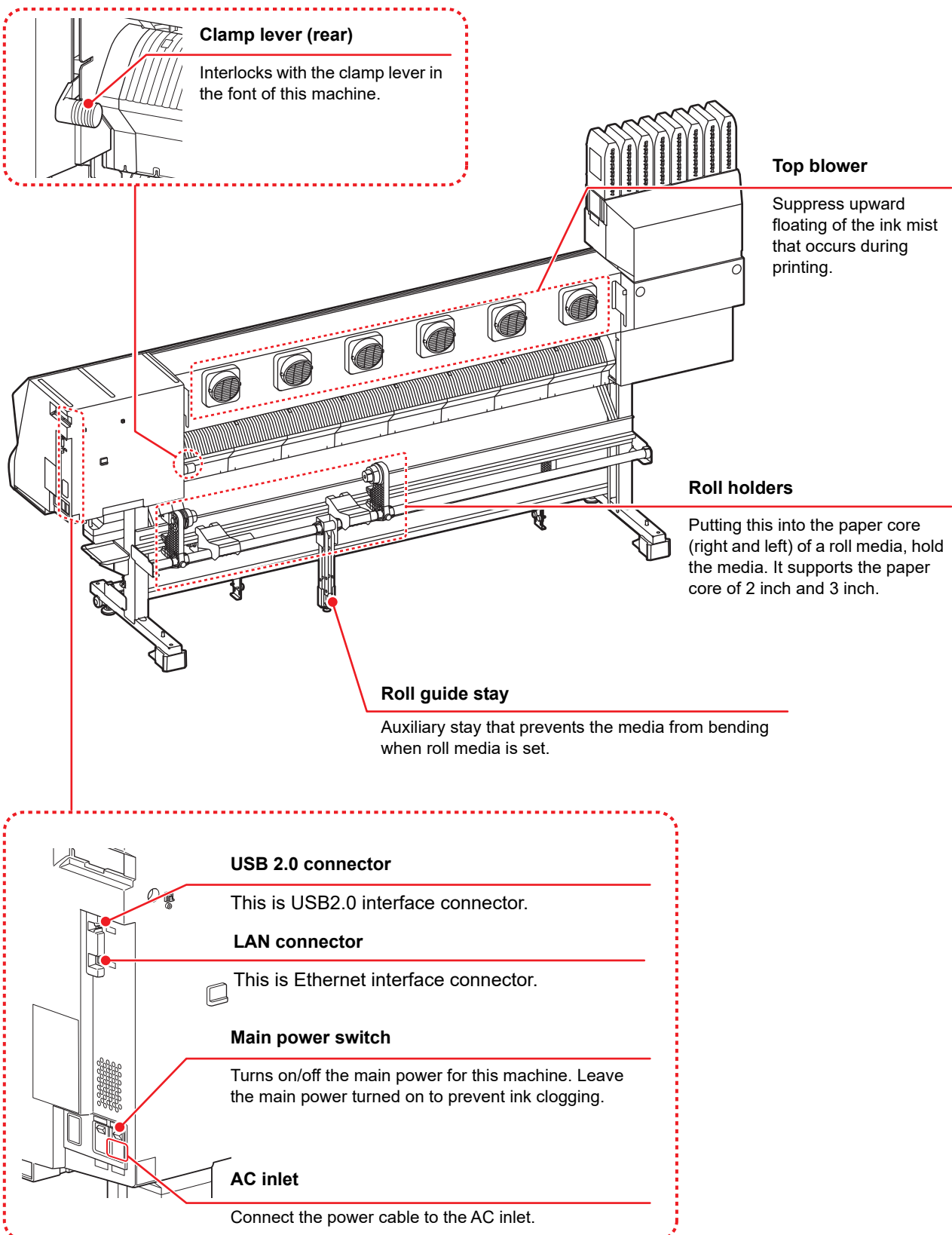

Operation Panel

Use the operation panel to make settings for printing or operate this machine.

SEL key
Changes over the functions of the function keys ([FUNC1]–[FUNC3]).

[FUNC1] / [FUNC2] / [FUNC3] key
Press this to set various functions or to do test printing. The function keys' functions are changed each time [SEL] key is pressed.

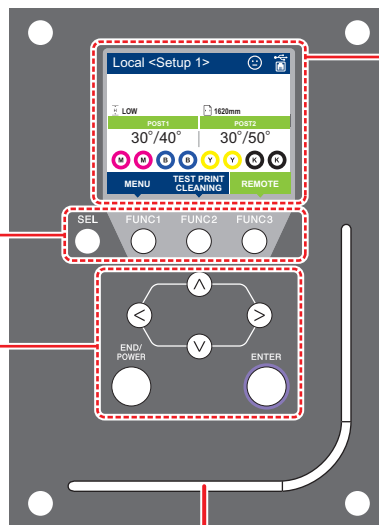

Display

Displays the following items:

- Printer status
- Head height (Carriage height)
- Set media width
- Heater temperature (current temperature/set temperature)
- Ink status ^{*1}
- Functions assigned to [FUNC1] to [FUNC3] ^{*2}

JOG key (Left, Right, Up, Down arrow keys)
Use these keys to shift the carriage or the media in [LOCAL]. Also use them to select an item of printing conditions.

[END/POWER] key
Cancels the last input value or returns the setting menu to the immediate higher level of the hierarchy. Also, press this to turn the power on or off. (Give it a long press to turn the power off.)

[ENTER] key
Registers the last input value as the setting value or goes to the immediate lower level of the hierarchy.

Status indicator lamp

Indicates the machine's status (printing, error occurred, etc).

Condition of Lamp	Condition of machine
OFF	Machine is in LOCAL mode, no print data has been received, and no errors have occurred.
Lit steady Light blue	Switched to REMOTE mode.
Flashing Light blue	Currently printing.
	In test printing: printing a pattern stored inside the machine.
Lit steady blue	Print data still remains in the machine.
Flashing red	Error has occurred.
Lit steady red	Error (SYSTEM HALT) has occurred.
Lit steady yellow	Firmware is being updated.



- The power switch under the operation panel lights in blue when the power is turned on, and off when the power switch is turned off. The ink clogging prevention function is periodically operated even when the power switch is OFF if the main power switch keeps being ON. (Auto maintenance function) P.1-5

















*1 : Ink Status

Status of the ink cartridge (remaining ink/error, etc.) is displayed using icons. Each icon is described below.

Icon	Contents																		
	The remaining amount of ink is displayed in 9 stages. The remaining amount decreases moving to the right. <table border="1" style="margin: 5px auto;"> <tr> <td></td> <td></td> <td></td> <td></td> <td></td> <td></td> <td></td> <td></td> <td></td> </tr> <tr> <td>ink full</td> <td>Approximately 1/8 consumed</td> <td>Approximately 1/4 consumed.</td> <td>Approximately 3/8 consumed.</td> <td>Approximately 1/2 consumed.</td> <td>Approximately 5/8 consumed.</td> <td>Approximately 3/4 consumed.</td> <td>Approximately 7/8 consumed.</td> <td>near end</td> </tr> </table>										ink full	Approximately 1/8 consumed	Approximately 1/4 consumed.	Approximately 3/8 consumed.	Approximately 1/2 consumed.	Approximately 5/8 consumed.	Approximately 3/4 consumed.	Approximately 7/8 consumed.	near end
ink full	Approximately 1/8 consumed	Approximately 1/4 consumed.	Approximately 3/8 consumed.	Approximately 1/2 consumed.	Approximately 5/8 consumed.	Approximately 3/4 consumed.	Approximately 7/8 consumed.	near end											
	Displayed at ink end (only when the 4-color ink set is used) and ink near end.																		
	Displayed when ink end or ink error occurs, and printing cannot be performed.																		
	Displayed when the expiration date of the ink consumption expires. Replace with new ink or use up as soon as possible. It is possible to print.																		

*2 : Functions assigned to [FUNC1] to [FUNC3]

Contents of functions assigned to [FUNC1] to [FUNC3] are described below.

Icon	Contents
	Displays "MENU" for setting functions.
	Displays maintenance functions such as test print, cleaning, etc.
	Shifts to REMOTE from LOCAL and starts printing.
	Displays adjustment functions such as FEED COMP, DROP.POScorrect, etc.
	Sets the heater temperature.
	Executes data clear.
	Suspends printing in REMOTE and shifts to LOCAL.
	Executes media cut.
	When there are multiple items on the MENU screen or other screens, it moves to the next page.
	When there are multiple items on the MENU screen or other screens, it moves to the previous page.
	Used for completing confirmation when warning message has been displayed and so on.
	Used for turning functions OFF or canceling them, for example, when turning heater settings OFF and so on.
	Some kind of setting or function is assigned. Operate according to the description of each function.
	Switches between enable/disable when selecting multiple items, for example, when selecting target head for cleaning and so on.
	Display the function description.
	Turn ON/OFF lights in the interior of the machine.



- The color of icons changes according to the state of the printer.
 - When the icon is green: The printer is in REMOTE mode.
 - When the icon is dark blue: The printer is in LOCAL mode.
 - When the icon is yellow: A warning has been issued.
 - When the icon is red: An error has been issued.

Media sensor

The media sensor detects the presence of the media and the media length.

This machine has two media sensors on the platen (in the rear).

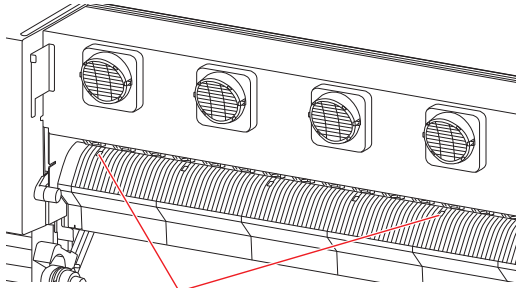

Media sensor



- When setting a media, be sure to cover the media sensors located on the rear of the platen. The media cannot be detected unless it is placed over the sensor.

Carriage

To the carriage, set an ink head for printing and "LED pointer" used for detecting the width of media, cutter unit for media cutting, etc. are built in.

Also, a lever that adjusts the head height is attached to the thickness of the media. (☞ P.2-4)

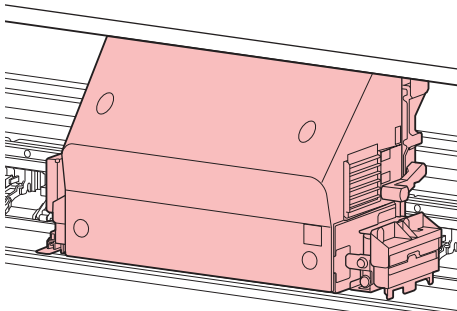

Cutter blade and slot for cutting

The carriage is provided with a cutter unit for cutting off the media that has been printed on.

The cutter cuts off the sheet of media along the slot for cutting on the platen.

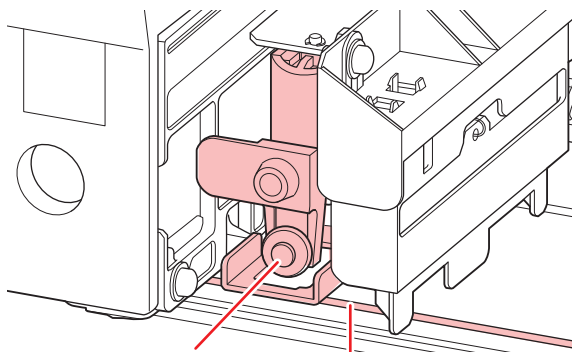

Cutter unit

Slot for cutting

Capping station

The capping station consists of the ink caps, the wiper for cleaning the heads, etc.

The ink caps prevent the nozzles in the ink heads from drying up.

The wiper cleans the nozzles in the heads.

The wiper is consumable. If the wiper is deformed or the media is stained, replace the wiper with a new one.



- Be sure to wear the attached safety glasses in cleaning within the capping station to protect your eyes against ink. Otherwise, you may get ink in your eyes.

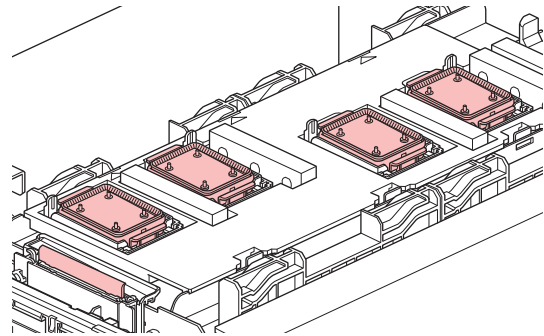

Pinch rollers and Feed rollers

This machine retains the media with the pinch rollers and feed rollers. During printing operation, the feed rollers feed the media forward.



- Keep the pinch rollers lifted up when this machine is not in use. If the pinch rollers are left lowered for an extended period of time, they can be deformed and fail to securely retain the media.

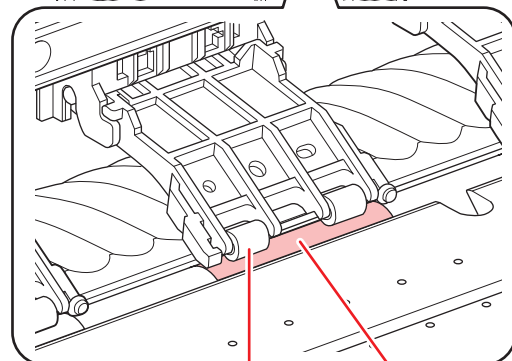
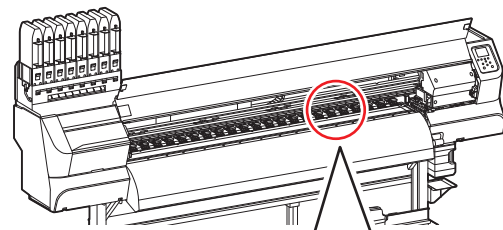

Pinch roller

Feed roller



- Change the mounting position of the clamp switching slider according to the media width.
- When installed the clamp switch slider, clamps up, and when removed, clamps down.

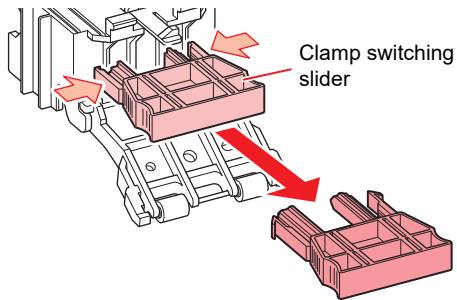

Connecting Cables

Connecting the LAN cable

When connecting LAN cable, be sure to follow the note below:

- Surely insert LAN cable until clicking noise sounds.
- Do not plug in or unplug any cable during data transferring.

Printing Via a Network

If printing via a network, you need to configure your network with the following environment.

If you configure it with an inappropriate environment, it could cause printing to stop.

- Firmly insert until you hear a click.
- Do not plug or unplug the cable while data is being transferred.
- Use LAN cables that are category 6 or higher.
- Use a switching hub and PC that support 1000BASE-T.



- Set the PC sending the print data and the printer to the same network.
- You cannot connect via a router.

● If connecting directly to the printer

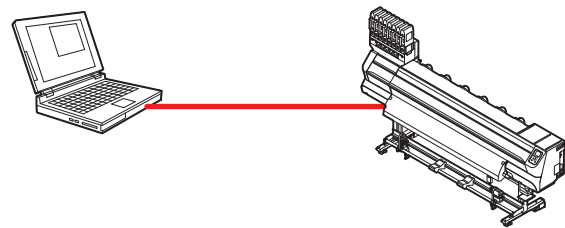

● If connecting via a switching hub

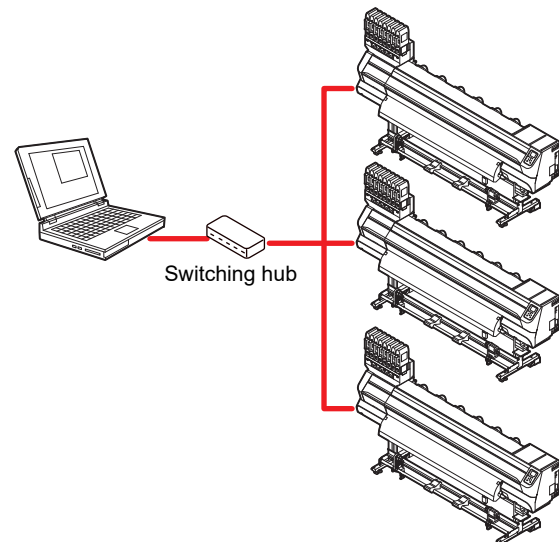

If the PC or device connected to the printer is not 1000BASE-T, you cannot perform printing. After connecting, check the following.

(1) Check the printer screen display.

- On the local screen or the media detection screen, press the [Enter] key several times to display the information screen.
- Check that "1000Mbps" is displayed for the LAN status item.



- If "100Mbps", "10Mbps", or "No connect" is displayed, you cannot print using the LAN.
- If "100Mbps" or "10Mbps" is displayed, you can use event mail (☞ Chapter3 "Setting event mail function").

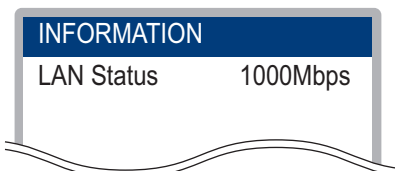

(2) Check the green light of the LAN connector.

- After turning on the machine, the lamp for the LAN connector will light up as follows.

Color	State	Condition
Green	Lighting	Connected with 1000BASE-T
	OFF	Connected without 1000BASE-T
Yellow	Lighting	Link-up
	Blinking	Receiving data
	OFF	Link-down



- If the yellow light only lights up, or is blinking, the status is not 1000Mbps. Check the specifications of the PC, device, and cables.

Connecting USB2.0 Interface Cable

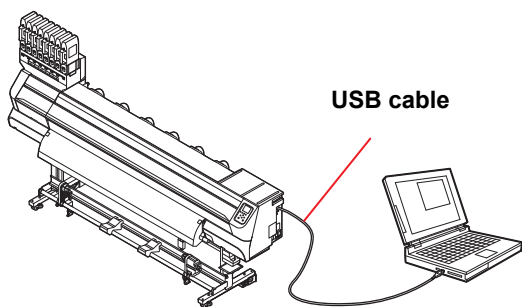

Connect the PC and this machine with the USB2.0 interface cable.



- Your RIP must be compatible with USB 2.0.
- Contact a RIP maker near your location or our office when the USB2.0 interface is not attached to the PC.

Notes on USB 2.0 Interface



- Your RIP must be compatible with USB 2.0.

When two or more TS55 machines are connected to one personal computer

When two or more TS55 machines are connected to one personal computer, the personal computer may not recognize all the TS55 machines normally. Reconnect the unrecognized TS55 machine to another USB port, if available, and check to see if it is recognized. If the TS55 machine is not recognized by the newly connected USB port, use USB 2.0 repeater cables available on the market.

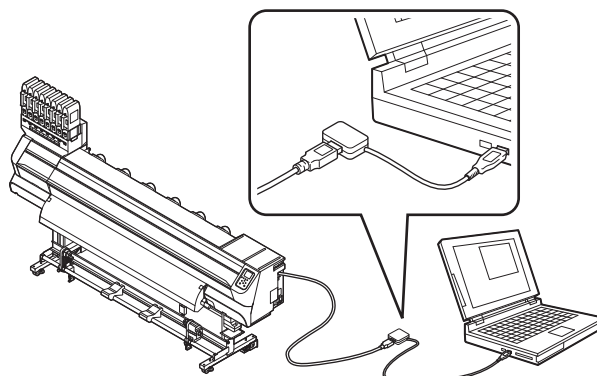

Notes on peripheral devices in USB high speed mode

When a peripheral device (USB memory or USB HDD) to be operated in USB high speed mode is connected to the same personal computer that a TS55 machine is connected to, the USB device may not be recognized. When TS55 is connected to the personal computer to which an external HDD is connected via USB, the speed of data output to TS55 may drop. That can cause the head unit to stop temporarily at the right or left end during printing.

Removing USB memory

If a USB memory module is inserted in the personal computer to which a TS55 machine is connected, click "Stop" in the "Safely Remove Hardware" window by following the instructions given there first and then remove the module.

Leaving a USB memory module inserted can cause [ERROR 10 COMMAND ERROR].

Copy the data onto the hard disk before outputting it for printing.

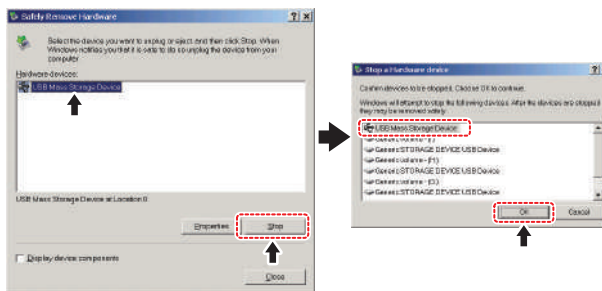

Connecting the power cable

- 1 Insert the power cable into an inlet of the machine.

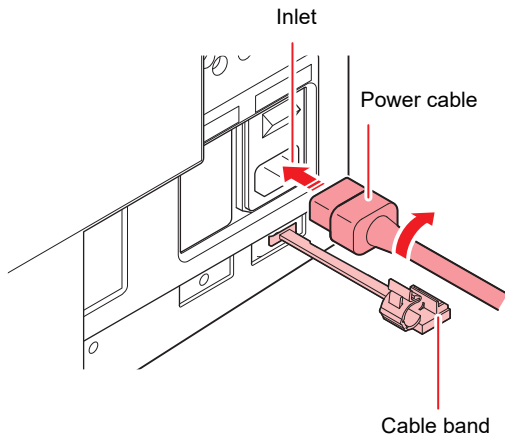

- 2 Secure a cable band.

- Secure the cable with the cable band attached to this machine.

- 3 Insert the power plug into a plug socket.

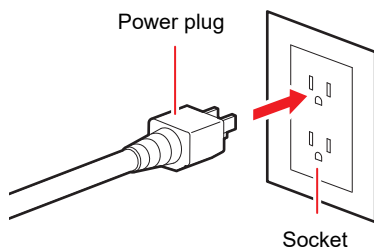

- Do not use any power cables other than the attached power cable.



- Be sure to connect the power cable to the outlet near this machine, and make sure that the power cable can be easily removed.
- Connect the power cable to the grounded outlet. Otherwise, it may result in fire or an electric shock.

Setting Ink

You can use aqueous sublimation dye ink (Sb610) for this machine.

- 1 Take out the 2L ink pack.

- Take out the 2L ink pack and the ink IC chip from a small cardboard box.

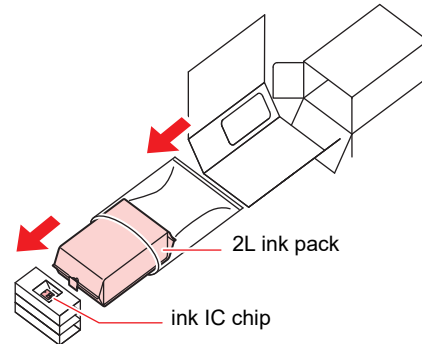

- 2 Mount the ink IC chip.

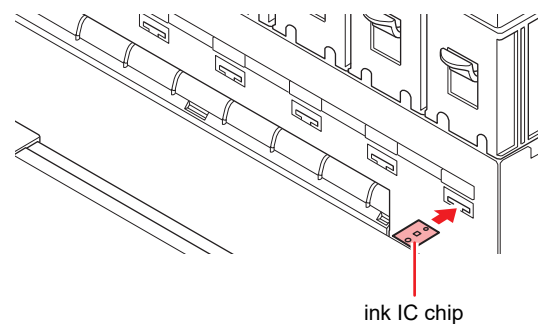

- Be careful of the ink IC chip direction. If it is set in the wrong direction, ink is not supplied properly.
- Make the metal side up.
- Do not touch the metal part while inserting. (The ink IC chip may be damaged by static electricity.)

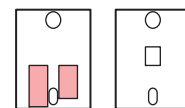

- 3 Take out an 2L ink pack and gently shake it from side to side at least 20 times.

- When to use the ink pack of the use, to prevent ink leaks when the pack is shaken, hold the ink pack connector with a paper towel, and shake the pack to the left and right slowly at least 20 times so that the ink runs slowly.



- Be sure to wear gloves and work.



- Remember to shake the bottle gently. Shaking the bottle violently can cause the ink to leak out.
- When the remaining ink is low, tilt the ink bottle all the way to the right and left until the bottle is in the upright position to ensure that the ink inside the 2L ink pack is thoroughly mixed.

Hold the cap of the ink bottle tightly with a paper towel, and gently shake the 2L ink pack.

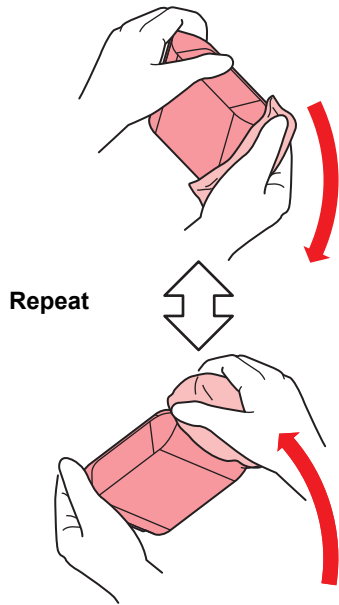

4 Put the 2L ink pack into the 2L eco case.
 (1) Open the 2L eco case as shown on the right.

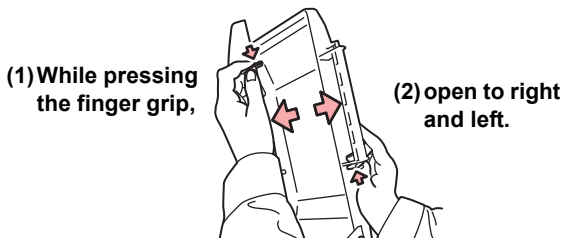

(2) Tear off the seal on the connector of the 2L ink pack.

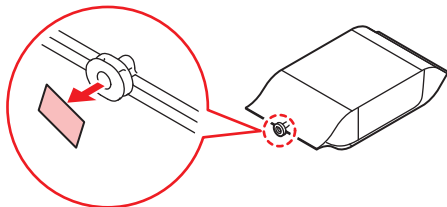

! Be careful of the ink IC chip direction. If it is set in the wrong direction, ink is not supplied properly.

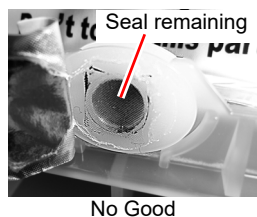

(3) Put the 2L ink pack facing the connector down, and close the 2L eco case.

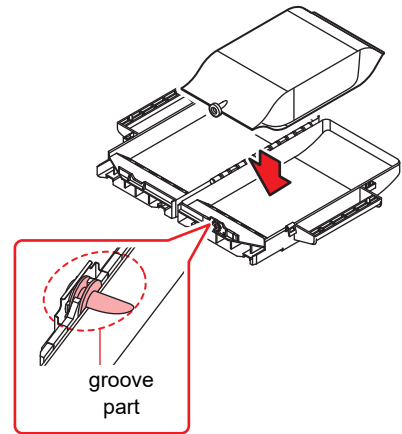

! • When putting the 2L ink pack, shape the pack referring to the label in the 2L eco case. If unshaped, you may not use up the ink.
 • Before closing the 2L eco case, make sure the connector of the ink pack is placed on the groove part of the 2L eco case. If it is not placed on the groove, it may not supply ink.

5 Attach the 2L eco case to the base.
 • Ink is supplied to the printer connecting to the 2L eco case.
 • After 1 or 2 minutes, EMPTY lamp on the connected printer goes out.

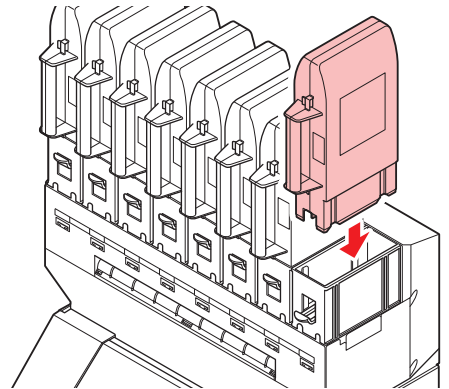

! • Push the 2L eco case all the way in. If not, it may not supply ink.







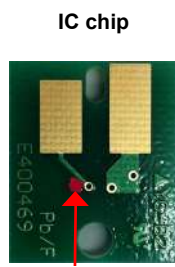



About IC chip

- The IC chip has information of ink color, remaining amount of ink, expiration data, etc?
- The mark indicating color information is pasted on the IC chip.



Mark indication position

Ink color and indication mark

Ink color	Indication mark
Magenta	 (1 red circle)
Yellow	 (1 yellow circle)
Light Magenta	 (2 red circles)
Cyan	 (1 blue circle/ 1 red circle)
Light Cyan	 (2 blue circles/ 1 red circle)
Light Black	 (2 black circles)
Fluorescent Yellow	 (2 yellow circles)
Fluorescent Pink	 (2 orange circles)

Replacing the 2L Ink Pack

Perform as follows when [INK END] or [INK NEAR END] is displayed on the display.



- When exchanging 2L ink pack, be sure to wear the included safety glasses and gloves. Ink may spatter and get in your eyes accidentally.



- Although approximately 10 cc of ink remains in the ink pack after use, the pack is filled so that the actual amount used is two liters.

● When [INK END] is displayed

1

Push the lever of the base down, and remove the 2L eco case.

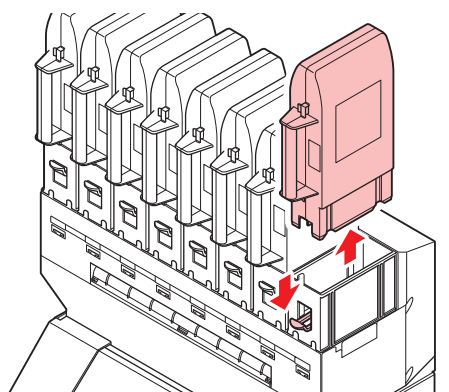

- When replacing the 2L ink pack, replace the male connector absorbent (attachment) periodically to prevent the stain in the base.
- Replace the absorbent every five to ten times of the 2L ink pack replacement.
- When replacing the absorbent, be sure to wear the included safety glasses and gloves.

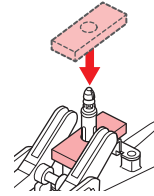

2

Remove the ink IC chip.

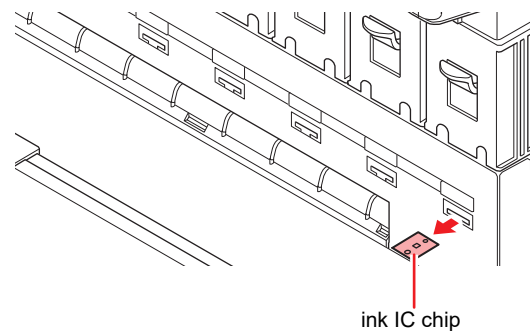

3

Open the 2L eco case, then replace the 2L ink pack.

- Keep the ink IC chip removed in the step 2 with used 2L ink packs.
(Not to mix with an ink IC chip of a new ink pack)

4

Mount the ink IC chip supplied with the replacement 2L ink pack.



- Be careful not to touch the metal part of the ink IC chip. There is the danger of damaging ink IC chip because of static electricity being generated.

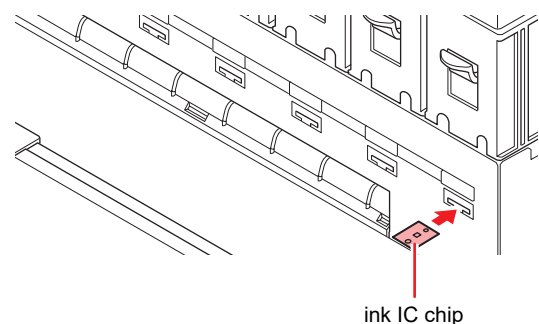



- Request an industrial waste disposal company for disposal of used ink packs.
- If removing an ink pack before it ends, follow the procedures below. Otherwise, you cannot accurately grasp the remaining amount of ink.
 - (1) Remove an ink pack from an eco case.
 - (2) Wipe ink adhering to inside of the connector part of the 2L ink pack with a cotton swab etc.

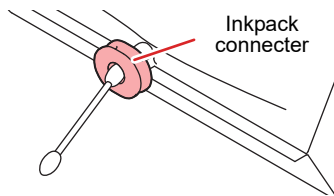

- (3) Remove the ink IC chip, and keep it with the ink pack.
- (4) If you use the ink pack again, set the pack, and mount the ink IC chip kept with the pack.

● When [INK NEAR END] is displayed

There is a little of ink left. It is recommended to replace the ink pack soon since ink may become empty in printing while printing is continuously enabled.



- During [INK NEAR END] is displayed, Auto cleaning does not operate. (P.3-8)

For Ink cartridge lamps

The condition of the ink cartridges set in the machine is confirmable with lamps located under the ink cartridges.

Ink cartridge lamps

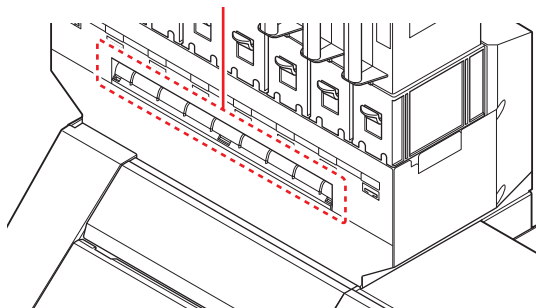

Condition of Lamp	Description
Lit to blue	No error (ink is being supplied)
OFF	No error
Lit or blinks to yellow	One of the following errors occurs. <ul style="list-style-type: none"> • Ink near-end • Expiration of a term of ink validity (one month)
Blinks to red	Expiration of a term of ink validity (two months)

Condition of Lamp	Description
Lit to red	One of the following errors occurs. <ul style="list-style-type: none"> • Ink end • No ink IC chip inserted • Other ink errors (P.5-10)

Restrictions of this machine

The expiration date of ink consumption is indicated on the ink packs. If used beyond the expiration date of ink consumption, ink ejection failure and color change may occur. You can print after the expiration date, but we recommend that you replace it with new ink or use it up as soon as possible.

- Ex.) When the expiration date is April 2020
- May : Replace with new ink or use up as soon as possible. It is possible to print.
 - June : Replace with new ink or use up as soon as possible. It is possible to print. (LED lits to yellow)
 - July : Cannot print. (LED blinks to red)



- The message appears on the display.

About Name

In this manual, the 2L ink pack, 2L eco case and ink IC chip are collectively described under the name of "ink cartridge".

Caution in handling of ink packs



- Use genuine ink packs for this machine. This machine functions by recognizing the genuine ink packs. In case of troubles caused by modified ink packs or the like, it shall be out of the warranty even within the warranty period.
- If the ink pack is moved from a cold place to a warm place, leave it in the room temperature for three hours or more before using it.
- Be sure to thoroughly consume the ink in the ink pack, once it is opened, within one month. If an extended period of time has passed away after opening the cartridge tank, printing quality would be poor.
- Make sure to store ink packs in a cool and dark place.
- Store ink packs and waste ink tank in a place that is out of the reach of children.
- Request an industrial waste processor for processing of empty ink packs.
- **Precautions for new installation and replacement of new spout rubber**
 - Moisten the surface of the spout rubber with maintenance solution sufficiently before inserting. Inserting the rubber into the eco-case without moistening may damage the rubber.

Important! •In that case, use a maintenance solution that is suitable for the ink type.

Outside rubber

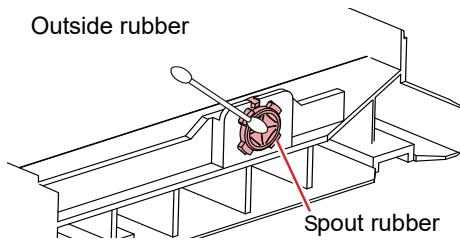

Inside rubber

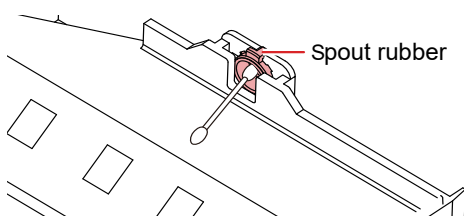

- **Precautions for using a partially used ink pack**
 - Wipe the ink off the inside of the ink pack connectors with cotton swab. Inserting the ink pack while the ink remains inside the connector part may cause ink leaking when the ink pack is used again.



•Do not insert the cotton swab too deeply. Ink may leak out of the ink pack and become unstopable.

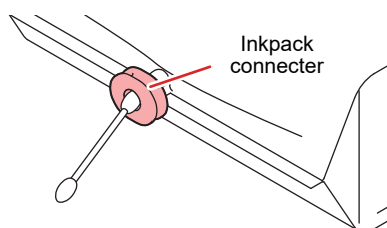

• Precautions for setting the eco-case in the main unit

- Confirm that the eco-case is fully inserted. Check whether there is a gap between the MBIS Base and the eco-case. If there is a gap, insert the eco-case again.

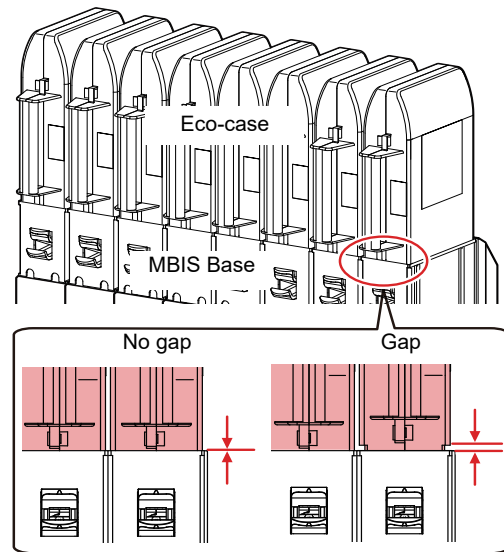

• Method of agitating the ink pack in the eco-case

When agitating the ink pack after removing
(Recommended method)

- Wipe off the ink from the connector part of the ink pack and the inside of the spout rubber before resetting.
- Cover the connector part of the ink pack with a paper towel (Wiping Rags, etc.) before agitating.

When agitating the ink pack together with the
eco-case

- Spout rubber with a paper towel (Wiping Rags, etc.) before agitating.

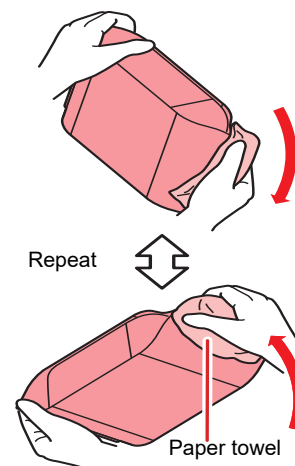

- Do not shake ink packs violently. This may result in ink leakage from the ink packs.
- Never refill the ink packs with ink. This may result in troubles. MIMAKI will not bear any responsibility for any damage caused by the use of the ink packs refilled with ink.



- Do not disassemble the ink packs.

Maintenance of Ink Pack

Shake the ink pack to agitate the ink in the pack once a week.

Otherwise, there may be a difference in color due to the ink sedimentation in the pack.

(On the main unit display, a screen prompting to run once a week is displayed)

1 Shake the 2L ink pack more than 20 times slowly to the right and left.

- In order to prevent ink from leaking when you shake the ink pack, cover the ink pack's connector part with a paper towel or the like and slowly shake it more than 20 times so that the ink flows back and forth in the pack.



- Be sure to wear gloves when working.



- Excessive shaking may cause ink leakage, so do it carefully.
- When the ink level is low, it may not be able to be stirred well, so tilt the ink pack until it is vertical.

Hold firmly with a paper towel and shake it slowly

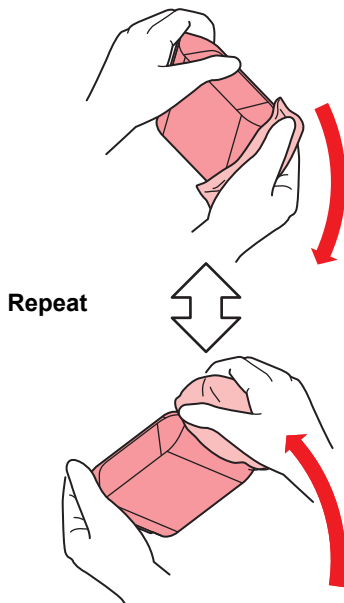

Media

Usable media sizes and notes for handling are described.

Usable sizes of media

Model		TS55-1800
Type of Recommended media	Transfer paper	
Maximum width	1,950 mm (76.8 in)	
Minimum width	210 mm (8.3 in)	
Maximum printing width	1,940 mm (76.4 in)	
Roll media	Thickness	1.0 mm or less
	Roll outside diameter	paper media: Φ 250 mm or less (Φ 9.8 in or less) others: Φ 210 mm or less (Φ 9.8 in or less)
	Roll weight	45 kg or less (88.2 lb or less)
	Roll inside diameter	2 or 3 inches
	Side printed	Side facing outward
	Roll end treatment	The roll end is gently fixed to the core with weak-adhesive tape or weak glue for easy removal.

Caution in handling of medias

Pay attention to the followings for handling of medias.



- Use media recommended by MIMAKI to ensure reliable, high-quality printing.**

Set the heater temperature to meet the characteristics of the media.

- Pay attention to the expansion and contraction of the media.**

Do not use media immediately after unpacking. The media can be affected by the room temperature and humidity, and thus it may expand and contract.

The media have to be left in the atmosphere in which they are to be used for 30 minutes or more after unpacked.

- Be careful to dusts on the edge face of the media.**

Some rolls have dusts contained in the package gathered on the edge surface of the roll. If you use as it is, the drawing quality may be degraded due to nozzle missing or ink drops. Be sure to set the roll after removing dusts adhering on the edge face of the roll.



- Do not use curled media.**

This may result in paper jamming.

If a regular-sized coated sheet of media is rolled and stored, the coated side has to face outside.

Menu mode

This machine has 4 modes. Each menu mode is described below.

NOT-READY mode

This is the mode in which the media has not been detected yet.

LOCAL mode

Local mode is the mode for the drawing preparation state.

All the keys are effective.

The machine can receive data from the computer. However, it does not perform printing.

Screen display in Local mode

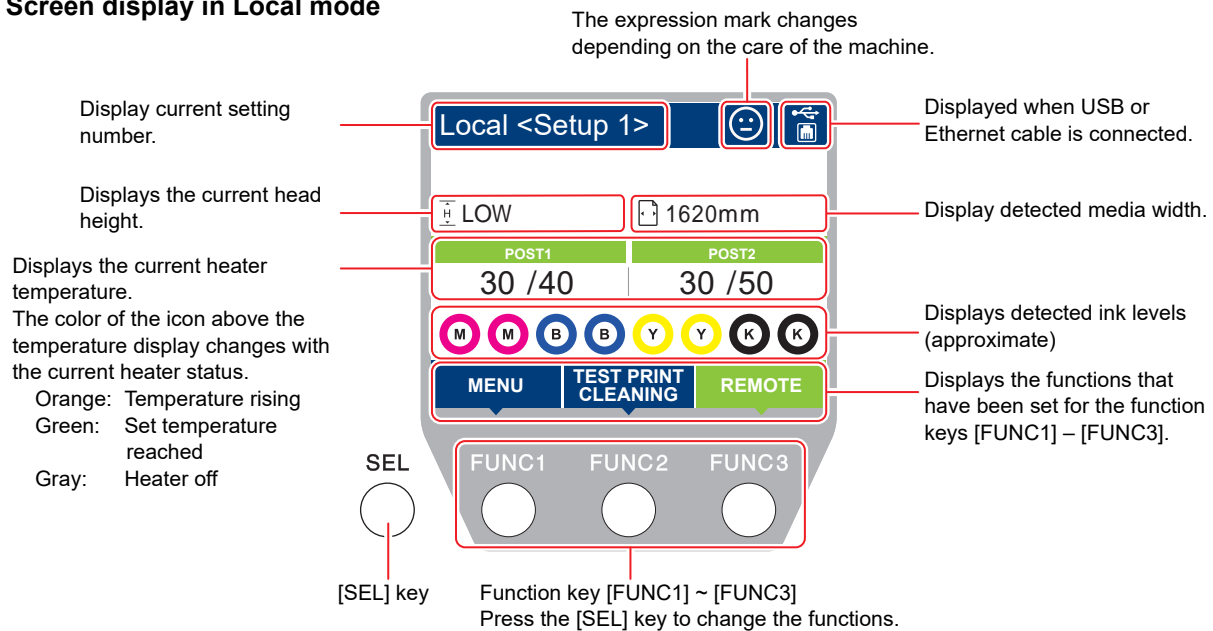

This mode permits the following operations:

- Pressing the JOG keys to set up a drawing origin and drawing area.
- Pressing the [ENTER] key to check the remaining amount of ink, the description of the cartridge error, the model name, the firmware version, and so on.

MENU mode

To set MENU mode, press the [FUNC1] key when this machine is in LOCAL mode.

In this mode, each function can be set.

REMOTE mode

This machine prints the data it receives.

Chapter 2

Basic Operations



This chapter

describes procedures and setting methods for ink and media preparation, and printing.

Workflow	2-2	Head Cleaning	2-13
Turning the Power ON/OFF	2-3	About head cleaning	2-13
Turning the Power ON	2-3	Perform head cleaning depending on the	
Turning the Power OFF	2-3	test printing result	2-13
Setting a Media	2-4	Setting of Media Correction	2-13
Adjusting the Head Height	2-4	Setting of Media Correction	2-13
Setting a roll media	2-5	If the Positions of Dots Shift... ..	2-14
Take-up device	2-9	Printing Data	2-14
Changing the printing origin	2-10	Starting a Printing Operation	2-14
Preparing for the Heaters	2-11	Stopping a Printing Operation	2-15
Changing the Temperature Settings		Deleting Received Data (Data Clear)	2-15
for the Heaters	2-11	Cutting a media	2-15
Test Printing	2-12		
Test Printing	2-12		

Workflow

1 Turning the Power ON/OFF

Referring to "Turning the Power ON/OFF" (☞ P.2-3).

2 Setting a Media

Referring to "Setting a Media" (☞ P.2-4).

3 Test Printing

Referring to "Test Printing" (☞ P.2-11).

4 Head Cleaning

Referring to "Head Cleaning" (☞ P.2-12).

5 Printing Data

Referring to "Printing Data" (☞ P.2-14).

Turning the Power ON/OFF

Turning the Power ON

This machine is provided with the following two power switches:

Main power switch :

It is located on the side of this machine. Keep this switch ON all the time.

[END/POWER] key :

Normally, use this key to turn the power ON/OFF.

The nozzle clogging prevention function periodically operates even with the [END/POWER] key turned OFF when the main power switch is turned ON.

1 Turn the main power switch ON.

- Set the main power switch located on the side of this machine to the "I" side.

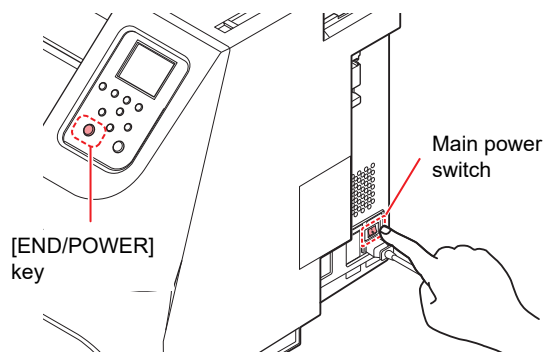

- The firmware version is displayed when the power is turned ON, and then the machine performs its initial operation.

2 Turn the power on, by pressing the [END/POWER] key.

- The machine enters LOCAL.

3 Turn ON the power of the connected PC.



- Turn the power ON after the front cover and maintenance cover are closed.
- The main power switch should always be set to "ON".
- The head nozzle may result in nozzle clogging if the main power switch is left OFF for a long time.

Turning the Power OFF

When having ended the operation of the machine, turn the power OFF by pressing the power switch located on the front side.

Check the following items when turning the power OFF.

- If the machine is receiving data from the PC or if there is any data that has not been output yet
- If the head has returned to the capping station
- If any error has occurred
(☞ P.5-11 "Error message")

1 Turn OFF the power of the connected PC.

2 Turn the power off, by giving the [END/POWER] key a long press.

- Do not turn OFF the main power switch located on the side of the machine.
- To use this machine again, press the [END/POWER] key.

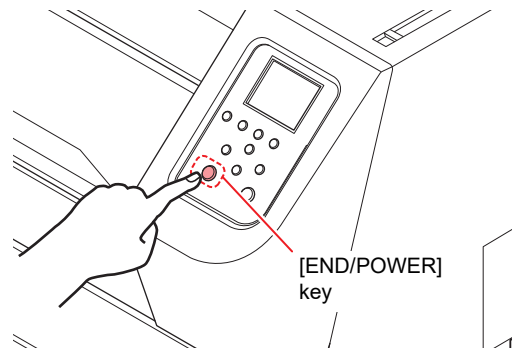

Cautions about Turning the Power OFF

● Do not turn the main power switch OFF.

When the main power switch is ON, the power periodically turns ON and the nozzle clogging prevention function (flushing function) operates.

When the main power switch has been turned OFF, the auto maintenance functions, such as flushing, do not operate, and this may cause nozzle clogging.

● Keep the front cover and the maintenance cover closed.

If the cover is opened, the auto maintenance function such as the flushing function does not work.

● Turn the power OFF after having checked the position of the head.

If the power is turned OFF in a state where the head has not returned to the capping station, the ink head dries, which may cause nozzle clogging.

In this case, turn the power ON again and check that the head has returned to the capping station, and then turn the power OFF.

● Do not turn the power OFF during printing.

The head may not return to the capping station.

● After having turned the power switch OFF by pressing [END/POWER] key, turn the main power switch OFF.

When turning the main power switch off for moving the machine or for solving the error or the like, press the [END/POWER] key a long time on the front of the machine, check the display is turned off on the operation panel, and then turn the main power switch off.

Setting a Media

This machine can be used with a roll media.
For usable medias, refer to P.1-16 "Usable sizes of media".



- Take care not to drop the media on your foot when setting the media. It may cause an injury due to the media.
- When setting a roll media, work by two or more people. Otherwise, you may hurt your back by the weight of the roll media.
- Adjust the head height prior to setting the media. If the head height is adjusted after the media is set, this may cause a media jamming, deterioration of the print quality or head damage.



- Adjust the head height before setting the media. Adjusting after setting the media may cause media jams, poor print quality, or damage to the head.
- With this machine, you can set media on the right side or in the center. When setting media, be sure to set it so that it covers one of the two media sensors on the back of this machine.
- If setting the media in the center, use the take-up extension cable.
- The head height is adjustable according to the purpose of use.

Adjusting the Head Height

Adjust the head height according to the thickness of the media you are using.

- The height of the head can be adjusted in three steps.
- If you change the height of the head, cleaning may be performed automatically to prevent nozzle clogging.
- If you change the height of head height, you may need to replace the wiper.

1

Press **(FUNC1)** (MENU) in LOCAL.

2

Press **(▲)** **(▼)** to select "MAINTENANCE", and press the **(ENTER)** key.

- Maintenance menu will be displayed.

3

Press **(▲)** **(▼)** to select "STATION MAINT.", and press the **(ENTER)** key.

4

Press **(▲)** **(▼)** to select "CARRIAGE OUT", and press the **(ENTER)** key.

5

Press **(▲)** **(▼)** to select "Move To Platen Right End", and press the **(ENTER)** key.

- The carriage moves over the platen.

6

Open the front cover.

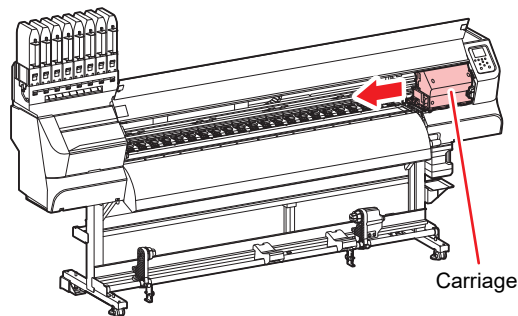

7

Adjust the height adjustment handle according to the media.

- Adjust the lever position with reference to the table below.

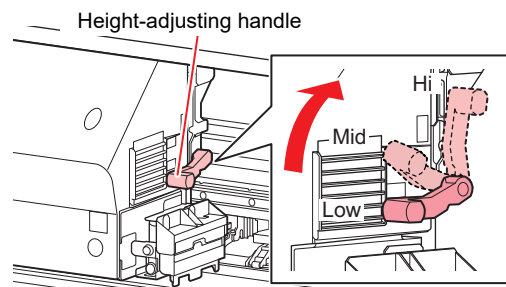

Range	Head height
Low	Low 2.8mm (factory setting position)
Mid	3.3mm
Hi	3.8mm

8

Attach the wiper according to the height of the head.

Range	Wiper
Low	Wiper (PN:SPC-0843)
Mid	
Hi	HiGap wiper (PN:SPC-0850)



- Be sure to use a wiper that matches the height of the head. It may cause discharge failure such as nozzle clogging or color mixing.
- If you change the wiper, the number of times the wiper is used is reset.

9

Press the **(ENTER)** key.

- The carriage automatically returns to the station.

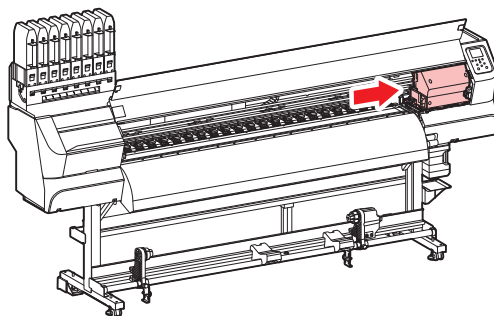

10

Press the **(END/POWER)** key several times to end the setting.



- If you adjust the head height, be sure to correct the dot position. (P.2-14 "If the Positions of Dots Shift...")

Setting a roll media

Set a roll media to the roll media hanger located on the back of this machine.

1 Move the roll holder located in the back of the device to the direction of the middle of the device.

- Loosen the roll holder fixing screw and then move it.

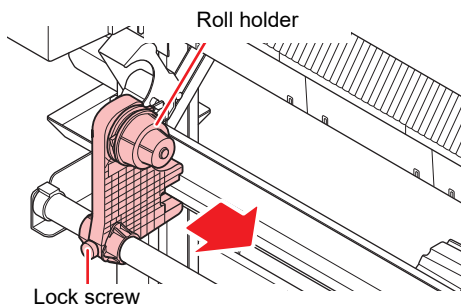

2 Check the clamp lever is lowered.

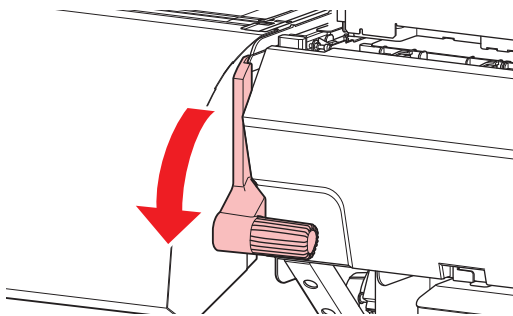

3 Move the roll holder to the roll setting position.

- You can set the media right or center in this machine.

If setting the media on the right side

- Check the roll stopper is not caught between the roll stopper arm and this machine.

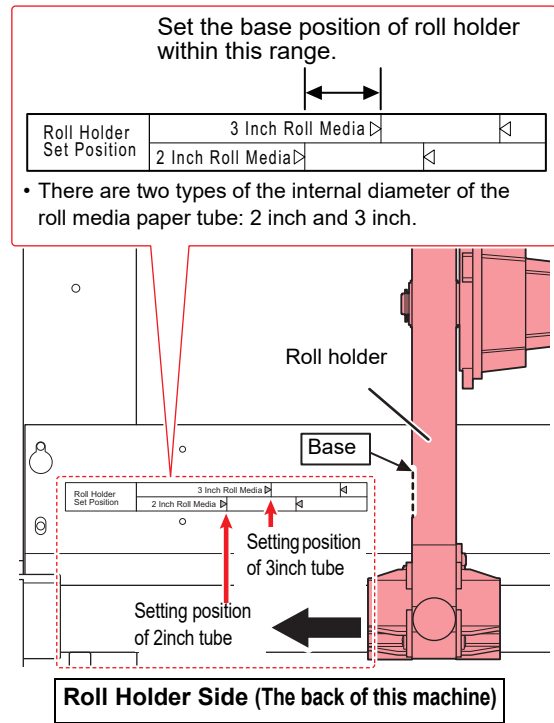

If setting the media in the center

- Move the roll holder so the media's set position is in the center of this machine.

4 Tighten the roll holder fixing screw.

- Check the Step 2 to 3 again.

5 Move the roll guide stay to match the position to set the media in.

- (1) After moving the stay, set down the adjuster foot.
- (2) Turn the screw on the adjuster foot once.
 - Make sure that the adjuster foot is fixed firmly to the floor.

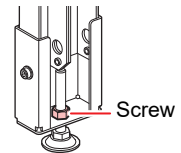

If setting the media on the right side

- Move the roll guide stay so that it is to the left of the right roll holder, as seen from the rear of the machine.

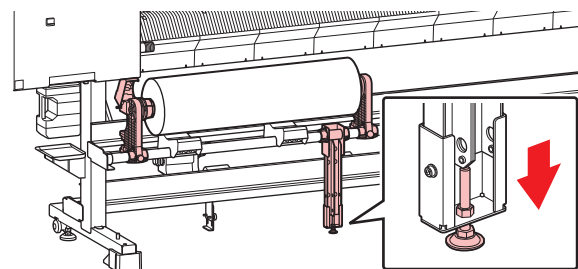

If setting the media in the center

- Move the roll guide stay to the center of the roll holder.

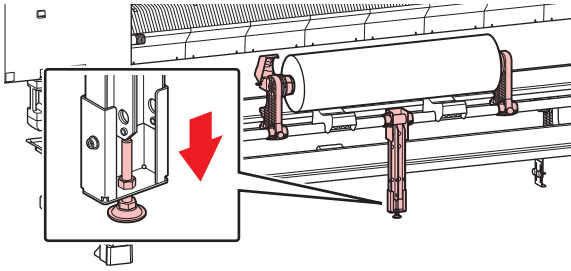

6 Set the left end of the core of the roll media on the left roll holder.

- Push the roll media onto the roll holder until the roll core is all the way seated.

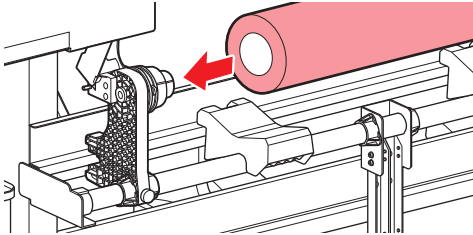

7 Loosen the screw of the right side roll holder then insert the holder into the core of the roll media.

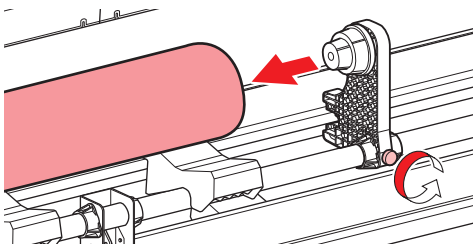

8 Raise the clamp lever in the rear of this machine.

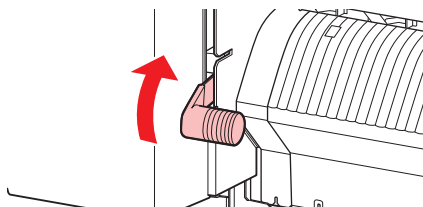

9 Insert the roll media in this machine.

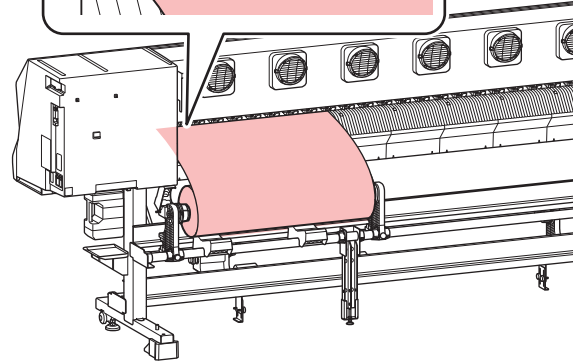
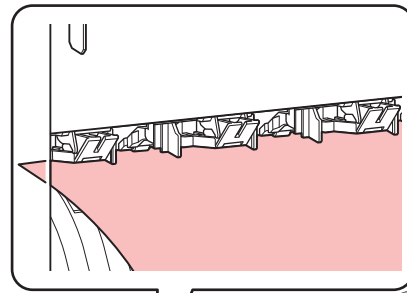

- The roll media can be smoothly inserted by slanting the media.

(1) Pull the media out of the roll to the head of the platen.

(2) Insert the media between the platen and the pinch roller.

- Pull the media out of the roll so that the media can be grasped from the front of the machine.



- If you set the roll media in the center, to prevent the media from moving, pull down the roll stopper towards you and insert the pin to temporarily lock it.

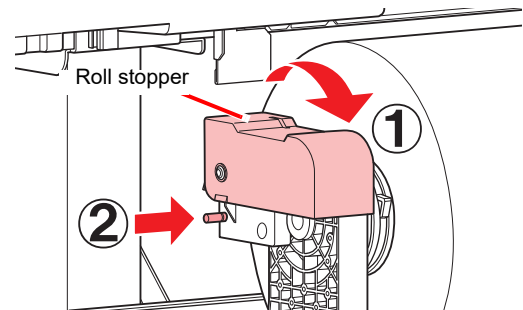

(3) Push down the clamp lever from the back of this machine.

- The media is held.

10 Pull out the roll media out.

(1) Open the front cover.

(2) Raise the clamp lever from the front of this machine.

(3) Pull out the roll media gently and then stop pulling when locked lightly.

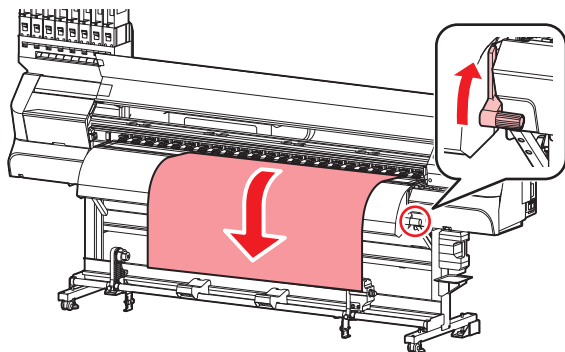

- If you set the roll media in the center, the lock will not engage.

11 Make the roll media even then lower the clamp lever.

- Pulling several positions of the media lightly, Lower the the clamp lever after confirming that the amount of the roll media pulled out is almost even.

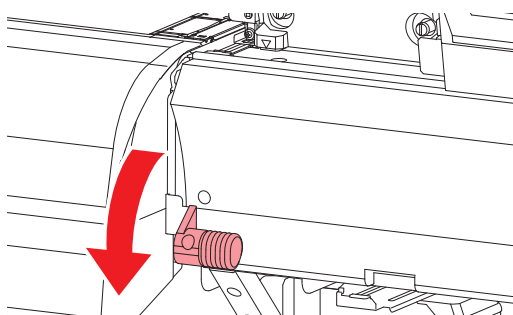

12 Hold the media with the media press gently.

- Set the media so that no media sticks out from the right end pinch roller to the right side.
- When using a thick media, remove the media press from the media before printing. In this case, set "Detect Speed" to "Standard" in "MEDIA DETECT" of the machine setting menu and detect it. Also, since the media width is detected at the position of the media press, it is necessary to change the non-printing area with "Margin" in the setting menu.

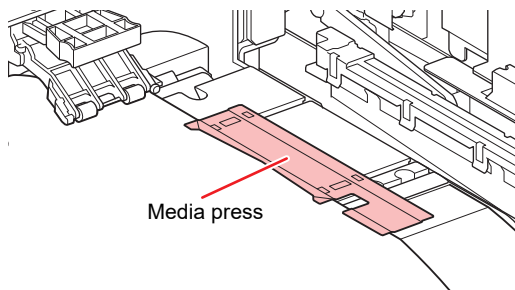

- When installing the media, align the media's right edge with the groove in the platen. Placing the media rightward of the groove will make it rise up if it moves obliquely, and this could cause damage to the head.
- This machine detects the media width using the media presses set to the left and right of the media. Be sure to set the media presses.
- If a media is misaligned to the right/left more than fixed position, a error message "MEDIA SET POSITION R" is displayed. Set the media again.
- If the print result remains on the media on the line through which the media detection sensor passes, the detection fails or the width may not be detected correctly. In that case, set "Detect Speed" to "Standard" in "MEDIA DETECT" of the machine setting menu and detect it.

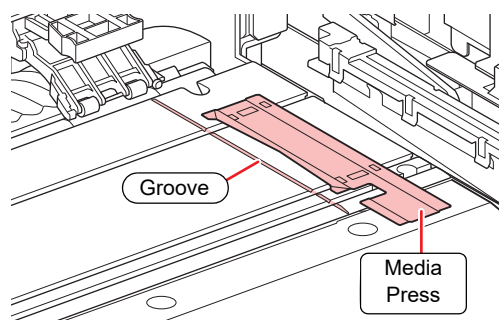

13 Set an empty core of the roll media on the take-up device.

- After setting the empty core, set down the take-up legs.

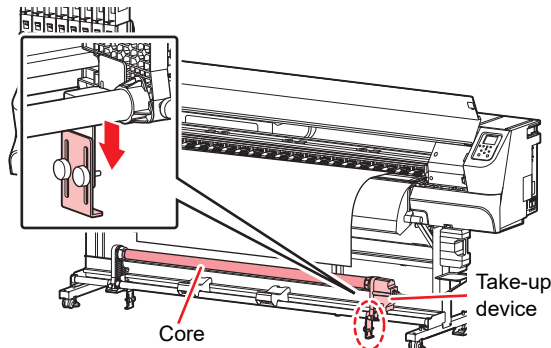

14 Close the front cover.

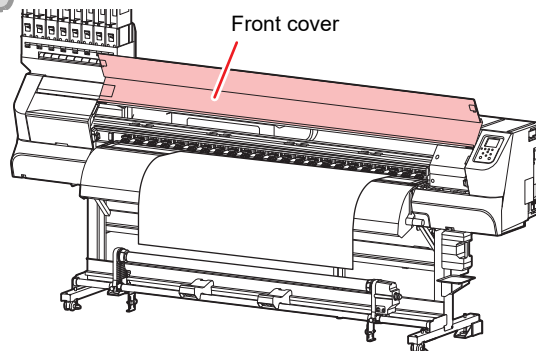

15 Press to detect media width.

- Detects the media width.
- When [MEDIA RESIDUAL] of the machine setting is "ON" (P.3-16), the screen for entering

media remaining amount is displayed after detecting the media width. (☞ P.2-9)

16 Secure the media on the take-up device. (☞ P.2-9)

- (1) Feed the media up to the core of the roll media of the take-up device by pressing [▼].
- (2) Fix the middle of the media with adhesive tape.
- (3) In the same manner, fix the left side and right side of the media.
 - Make sure that there is no slack or wrinkle on the media in such condition that the roll media is pulled to right and left evenly, and then stick the tape.

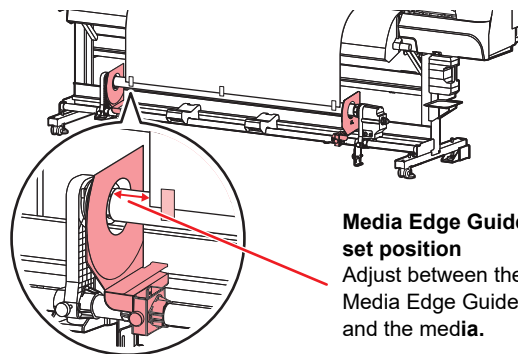
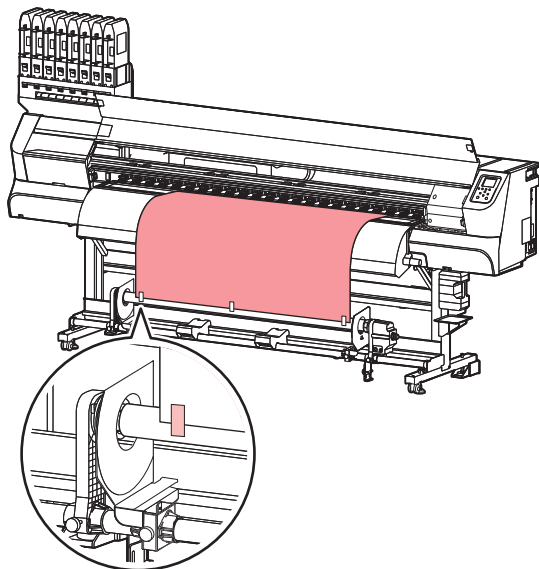

Media Edge Guide set position
Adjust between the Media Edge Guide and the media.

Media Edge Guide

The end face of the taken up roll media may shift laterally. In such cases, use the Media Edge Guide to prevent the lateral shifting.

1 Adjust and fix the position of the Media Edge Guide.

- The set position of the Media Edge Guide differs depending on the diameter of the roll media of before printing. Refer to the table below for adjustment.

Roll media diameter	Media Edge Guide set position
~Φ120mm	1mm
~Φ160mm	3mm
~Φ200mm	5mm

Entering the media remaining amount

When [MEDIA RESIDUAL] of the machine setup is "ON" (☞ P.3-15), the screen for entering media remaining amount is displayed after detecting the media width.

- 1 Display the screen for entering media remaining amount.

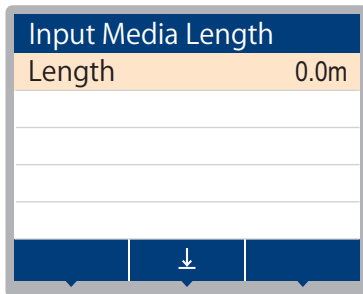

- 2 Press **▲▼** to enter the media remaining amount.

- 3 Press the **ENTER** key.

About the media residual print

When [MEDIA RESIDUAL] of the machine setup is "ON" (☞ P.3-15), You can print a list of print the current date and media remaining.

- 1 In Local, Press **▲▼◀▶**.
 - It enters into the origin setting mode.
- 2 Press the **FUNC3** key.
 - Appear the confirmation screen of media remaining print.
- 3 Press the **ENTER** key.
 - Media residual print starts.

Take-up device

With the switch of the narrow take-up device, select the take-up direction of the media or others.

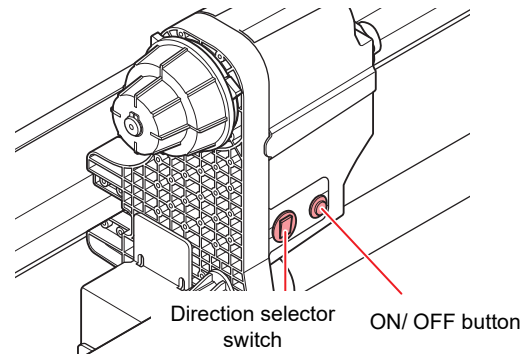

Take-up unit	Direction selector switch	UP (REVERSE)	The take-up device winds the media with the printed side facing in.
		DOWN (FORWARD)	The take-up device winds the media with the printed side facing out.
	ON/OFF button		Turns the winding motion on/off. (When you press the button and operate the take-up device, the device keeps taking up the media until you press the button again. *1)

*1. You can also change the setting so that the taking-up operation only lasts while the ON/OFF button is being pressed. For details, refer to "Setting Take-up unit" (☞ P.3-15) in machine setups.

Setting the torque limiter

The take-up device is provided with a torque limiter. The take-up torque can be adjusted with the torque limiter. (The torque limiter is set to "Medium" at delivery.) When adjusting the torque limiter, use the attached Torque adjustment handle to loosen the torque limiter or tighten it by hand.

Clockwise turn :

Adjust by hand. Increases tension (thick and heavy media such as tarpaulin).

Counterclockwise turn :

Adjust with the torque adjustment handle. Decreases tension (light weight media).

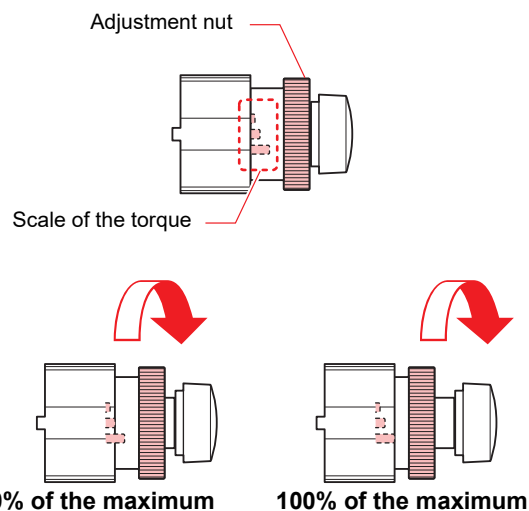

1 Attach the torque adjustment handle to the torque limiter and adjust.

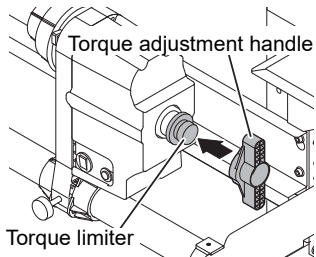

Loosen with the torque adjustment handle : Decreases tension

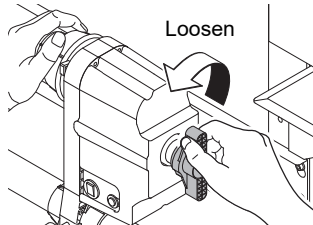

Tighten by hand : Increases tension

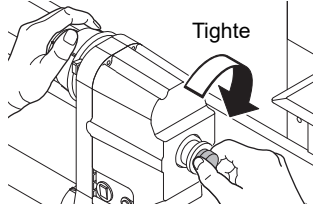

- If the adjustment of the torque limiter is weak, the media can not be reliably taken-up.
- Do not take-up the media manually.
- When the tension is set to be high, depending on the type of media, the edge of the roll media may shift in the lateral direction. In such a case, use the media edge guide (P.2-8).
- If you use the torque adjustment handle and tighten it too hard, the take-up device may be damaged.



Changing the printing origin



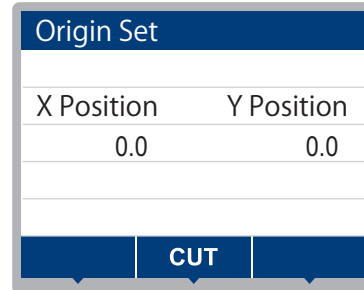

The position of the printing origin can be changed. Moving the LED pointer to the changing position and deciding the position.

1 In Local, Press .

- It enters into the origin setting mode.



2 Press to set a light point of the LED pointer to the changing position.

- Select the carriage and media, moving the point with [][][][].

3 After determining the origin, press the key.

- The printing origin is changed.

Typical setting position of printing origin

The printing origin in the depth direction (X') is positioned at about 75 mm rearward from the slot for cutting on the platen. The printing origin in the scanning direction (Y') is positioned at 15 mm from the right end of the media. The value in the scanning direction (Y') can be changed using [MARGIN] in FUNCTION mode. (P.3-7) This can be changed by using the Jog key.

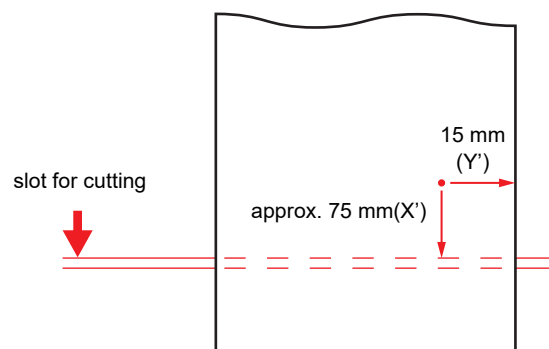

Preparing for the Heaters

Changing the Temperature Settings for the Heaters

You can change/save the temperature settings for the heaters with "Heater" of the setting mode. (☞ P.3-6)
Here, changing method of the temperature set in the setting mode is explained. Set the heater temperature according to the characteristics of the media you use. The temperature can be adjusted even during printing. When the temperature is 25°C, the recommended temperature for each heater is as follows.

Heater	Temperature
POST1	30 °C
POST2	40 °C
OPT	40 °C

The temperature of the heaters has been set to "OFF" as default.

It may take several minutes to tens of minutes for the set temperature to be reached, depending on the ambient temperature. When $\pm 3^{\circ}\text{C}$ of the set temperature is reached, the equipment can print.

1 Press the **SEL** key, and then press the **FUNC2** (Heater) in LOCAL.

- The heater temperature adjustment screen will be displayed.

2 Press **▲▼◀▶** to set the temperature of each heater.

Heater selecting: Select with **◀▶**

Temperature setting: Set with **▲▼**

- The heater is heated. When the heater temperature reaches the set value, the heater icon on the display turns green.



- Press **[FUNC3]** (OFF) in Step 2 to turn all heaters OFF.
Or, press **[FUNC1]** to raise the POST1/POST2 heaters in 10°C increments.

3 Press the **ENTER** key to stop heating.

- The screen returns to LOCAL.

Notes on usage environment



- Use this machine in an environment of 20°C to 30°C. Temperature may not rise to the set value depending on the ambient temperature conditions.

Test Printing

Print a test pattern to check that there are no discharging defects such as nozzle clogging (slight touching of ink or nozzle missing).

Relationship between head row and test pattern

The relations between head row and test pattern print position are as follow.

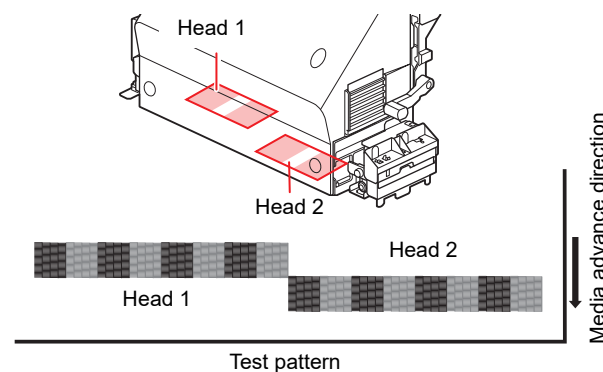

Note on test printing



- When using a roll media, rewind the media by hand before printing so that it is not loose. When the roll media has not been rewound tightly, it may cause image quality to deteriorate.

Test Printing

Print a test pattern to check that there are no discharging defects such as nozzle clogging (slight touching of ink or nozzle missing).

In addition, you can select the orientation of the test pattern to print from two types in order to perform test printing repeatedly. Select one depending on your use.

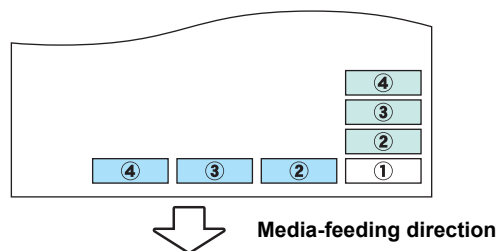

- : When the test pattern orientation is "FEED DIR."
- : When the test pattern orientation is "SCAN DIR."

Check before test printing.

- If a media has been set (☞ P.2-4)
- If the origin position has been set
- If the head gap has been adjusted (☞ P.2-4)
- If the necessary settings have been configured for nozzle recovery (☞ P.4-14)

1 Press the **FUNC2** (TEST PRINT/CLEANING), and then press the **ENTER** key in LOCAL.

- The test pattern orientation screen will be displayed.

2 Press **▲▼** to select the test pattern orientation (SCAN DIR./ FEED DIR.).

- The orientation selected here will be reflected on when you will print next time.
- When performing test printing after having changed the orientation from "SCAN DIR." to "FEED DIR.", the line is fed to the position of the first test printing.

3 Press the **ENTER** key.

- Test printing starts.
- When the printing has been completed, the screen returns to LOCAL.

4 Check the printed test pattern.

- When the result is normal, end the operation.
- When the result is abnormal, perform head cleaning. (☞ P.2-12)

Normal pattern

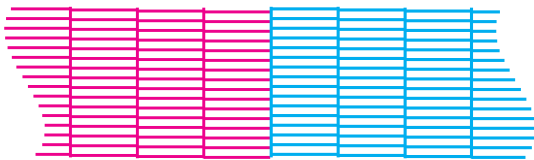

Abnormal pattern

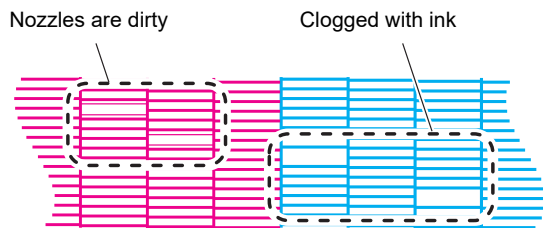

- The printer name, Firmware version, print date / time, machine serial number, and ink type are printed along with the test print. Other displays are for service only.

Head Cleaning

About head cleaning

Check the printed test pattern result and perform cleaning depending on the status.

Select one from the three types below:

NORMAL : When any line is missing

SOFT : When only head wiping is needed (when lines are bent)

HARD : When poor image quality cannot be improved even by NORMAL or SOFT cleaning

Perform head cleaning depending on the test printing result

There are three types of head cleaning. Use one by checking the test pattern.

1 Press the **FUNC2** (TEST PRINT/CLEANING) → **▼** → **ENTER** key in LOCAL.

- CLEANING MENU will be displayed.

2 Press **▲▼** to select the cleaning type.

- **NORMAL** : Select this if any line is missing.
- **SOFT** : When only head wiping is desirable. (in case of bent lines)
- **HARD** : Select this if inferior printing cannot be improved even by [NORMAL] or [SOFT] cleaning.

3 Select the head to be cleaned, and press the **ENTER** key.

4 Perform test printing again, and check the result.

- Repeat the cleaning and the test printing until the printing result becomes in normal.



If image quality is not improved even after executing the head cleaning, please do the following.

- Cleaning the Wiper (☞ P.4-7)
- Cleaning the Cap (☞ P.4-8)
- Nozzle cleaning (☞ P.4-9)
- Nozzle Recovery Function (☞ P.4-13)

Setting of Media Correction

Correct the media feed amount to match the type of media you are using.

If the correction value is not appropriate, stripes may appear on the printed image, thus resulting in a poor printing.



- On completion of [MEDIA COMP.] during use of a roll media, the media returns to the printing origin. Then the roll media in the rear of this machine will slacken. Before printing, take up the slack in the roll media by hand; a loose roll media can result in an inferior image quality.
- When printing with a take-up device, set the media first and then perform media correction.

Setting of Media Correction

A pattern for media correction is printed and a media-feeding rate is corrected. This setting applies to all print conditions.



- Two bands are printed in the correction pattern.
- Make adjustment so that an even color density is obtained in the boundary between the two bands.

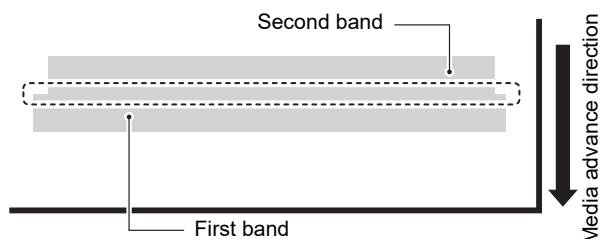

1

Set a media.

- Setting a roll media (P.2-5)

2

Press the **SEL** key, and then press the **FUNC1 (ADJUST)** in LOCAL.

- ADJUST MENU will be displayed.

3

Press the **ENTER** key.

4

Make sure that the Print Condition Correction is [OFF], and then press the **ENTER** key.

- When it is [ON], press **FUNC1** to turn it [OFF].

5

Check the correction pattern and enter a correction value.

- A screen for entering the correction value will be displayed.
- **Enter a correction value in "+":**
The boundary between the two bands is widened.
- **Enter a correction value in "-":**
The boundary between the two bands is narrowed.
- When you change the correction value by "30", the width of the boundary changes by about 0.1 mm.

Setting of Media Correction (Print Condition Correction)



- 1Pass and 2Pass can be set to feed correction in the print condition.

1

Set a media.

- Setting a roll media (P.2-5)

2

Press the **SEL** key, and then press the **FUNC1 (ADJUST)** in LOCAL.

- ADJUST MENU will be displayed.

3

Press the **ENTER** key.

4

Make sure that the Print Condition Correction is [ON], and then press the **ENTER** key.

- When it is [OFF], press **FUNC1** to turn it [ON].

5

Press the **▼** to select the print condition to be used, and then press **ENTER** key.



- The following print conditions can be selected.
- Correction value is reflected when the setting by print condition sets [OFF] except for the following conditions.

4-color ink set

1. 480×600 1Pass
2. 480×600 2Pass
3. 600×600 1Pass
4. 600×600 2Pass

6,7,8-color ink set

1. 480×600 2Pass
2. 600×600 2Pass

6

Check the correction pattern and enter a correction value.

- A screen for entering the correction value will be displayed.
- **Enter a correction value in "+":**
The boundary between the two bands is widened.
- **Enter a correction value in "-":**
The boundary between the two bands is narrowed.
- When you change the correction value by "30", the width of the boundary changes by about 0.1 mm.

If the Positions of Dots Shift...

When the condition for printing (media thickness/ink type/etc.) has been changed, perform the following operation to correct the ink drop position for bidirectional (Bi) printing and obtain the proper printing result.

Example of a Printed Pattern

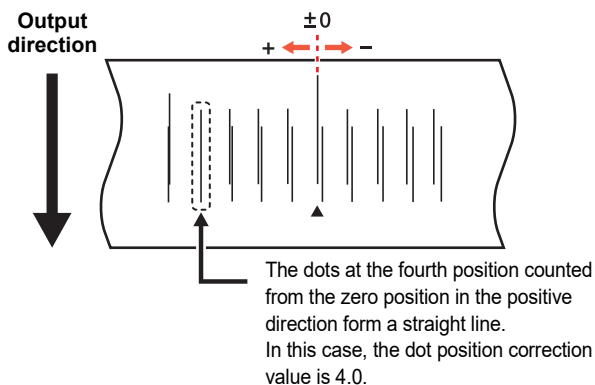

- 1** Press the **SEL** key, and then press the **FUNC1 (ADJUST)** in LOCAL.
 - ADJUST MENU will be displayed.
- 2** Press **▼**, and then press the **ENTER** key.
 - "DROP.POScorrect" will be selected.
- 3** Press the **ENTER** key.
 - Printing of the Drop position correct printed pattern will start.
 - Multiple test patterns are printed. (The printed patterns are called Pattern 1, Pattern 2, Pattern 3... in the order of printing.)
- 4** Press **▲▼** to enter a correction value of Pattern 1, and then press the **ENTER** key.
 - **Corrected feeding rate:** -40 to 40
 - Check the test patterns. The position where an outward feeding line and a return feeding line become one straight line is the correction value.
 - When the correction value is not between -40 and 40, adjust the height of the printing heads and then perform the operations in Step 2 and later.
- 5** In the same way as in Step 4, enter a correction value of Pattern 2 and later, and then press the **ENTER** key.
- 6** Press the **END/POWER** key several times to end the setting.

Printing Data

Starting a Printing Operation



- When using a roll media, rewind the media by hand before printing so that it is not loose. When the roll media has not been rewound tightly, it may cause the image quality to deteriorate.

1 Setting a Media (P.2-4)

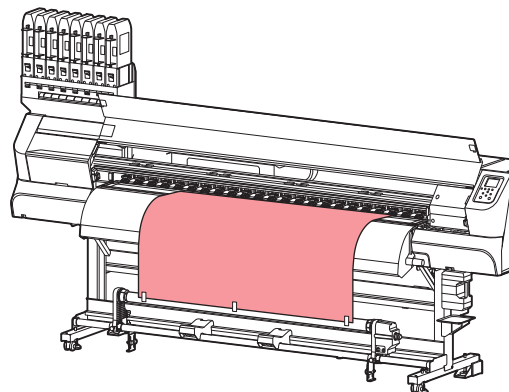

2 Transmit data to be printed from the PC.

- The status indicator lamp blinks and the printing conditions are displayed.
- For the method of data transmission, see the instruction manual for the output software.

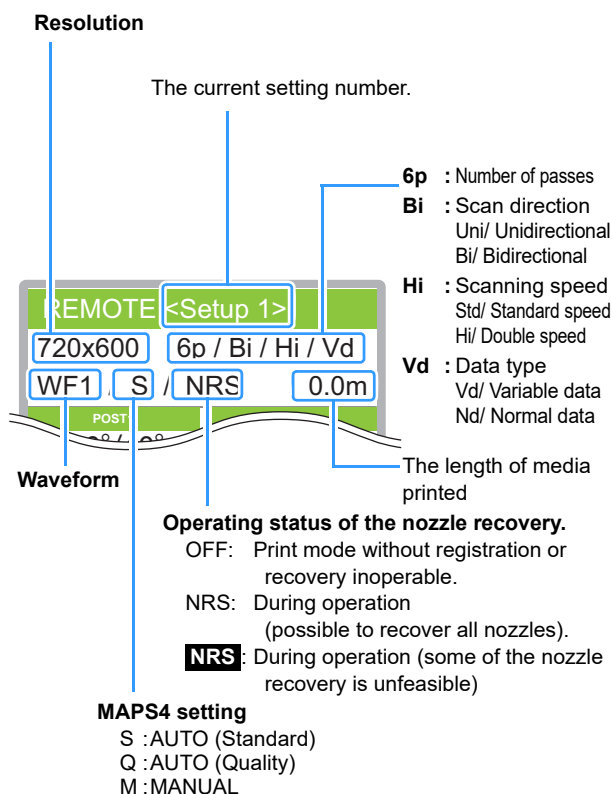

3 Start printing.

- The printing speed may change, depending on the width of the set media or the position of the print origin even when the same data is printed. This is because of a difference in resolution.

Stopping a Printing Operation

Perform the following operation when stopping a printing operation halfway.

- 1 Press the **FUNC3** (**LOCAL**) during printing.
 - The printing operation stops.
 - Interrupt data sending at the PC side during the data is sent from the PC.
 - Printing restarts from the interrupted data by repressing the **[REMOTE]** key.

Deleting Received Data (Data Clear)

When you want to stop printing, delete the already received data.

- 1 Press the **SEL** key, and then press the **FUNC3** (**DATA CLEAR**) in **LOCAL**.
- 2 Press the **ENTER** key.
 - The received data is erased then it returns to the Local.

Cutting a media

By using the keys on the operation panel, you can cut the media at any position.

- 1 In Local, Press **▲▼◀▶**.
 - It enters into the origin setting mode.
 - By pressing **[▼]**, feed the media to the cutting position.

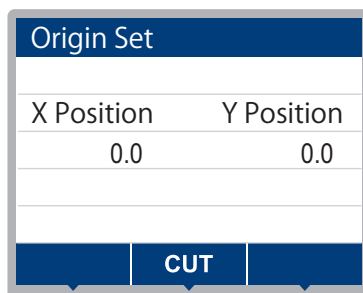

- 2 Press the **FUNC2** **ENTER** key.
 - The media is cut.
 - When the cutting has been completed, the current mode returns to LOCAL.

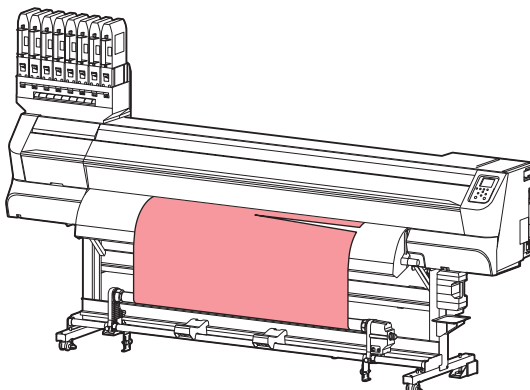

Chapter 3

Setup



This chapter

describes the various setting of this machine.

About SETUP MENU	3-2	Setting a LANGUAGE.....	3-15
SETUP MENU table.....	3-3	Setting a Time.....	3-15
Register the optimal print conditions to match the use.....	3-4	Setting Unit (Temperature/ Length)	3-16
Setting of Media Correction.....	3-4	Setting a KEY BUZZER.....	3-16
If the Positions of Dots Shift.....	3-5	Setting the VIEW FEED.....	3-16
Setting the HEATER	3-6	Setting the space between prints.....	3-16
Setting of Logical Seek	3-6	Setting the SPACE FEED MODE	3-16
Setting of Overprint	3-6	Set the network.....	3-17
Setting of Drying Time.....	3-7	Setting event mail function.....	3-17
Setting of Left and Right Margins.....	3-7	Automatic remote.....	3-21
Setting of Vacuum Fan.....	3-7	Lighting	3-21
Setting of Feed Speed	3-8	Feeding before cut.....	3-21
Setting Auto Cleaning	3-8	Initializing the Settings.....	3-21
Setting External heater.....	3-9	About NOZZLE CHECK MENU	3-23
Setting of MAPS4.....	3-9	INFORMATION MENU table	3-23
Pass density correct.....	3-10	Printing Check Flow.....	3-24
Setting Pre-feed	3-10	Printing Operations at "Nozzle Missing" Judgment and Error Occurrence	3-24
Change of setting type name	3-10	Setting the Printing Check.....	3-25
About MACHINE SETUP MENU	3-11	Setting the NOZZLE RECOVERY	3-25
MACHINE SETUP MENU table	3-12	Setting the Judgment Condition.....	3-25
Setting a AUTO Power-off.....	3-14	About INFORMATION MENU	3-26
Setting Take-up unit.....	3-14	INFORMATION MENU table	3-26
Setting Top Blower.....	3-14	Displaying the Information	3-27
Setting the Display of Media Residual	3-14	Display maintenance status (local guidance)	3-27
Setting the Media Detection	3-15		

About SETUP MENU

On SETUP MENU, you can set the print conditions to match the media you usually use.

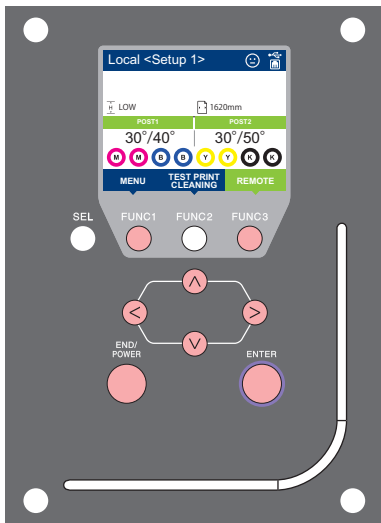

- FUNC1** : Press this to select SETUP MENU, or to switch to the previous screen.
- FUNC3** : Press this to switch to the next screen.
- ▲ ▼** : Use these to select a setting item.
- ENTER** : Press this to confirm a setting, etc.

◆ SETUP MENUs at-a-glance

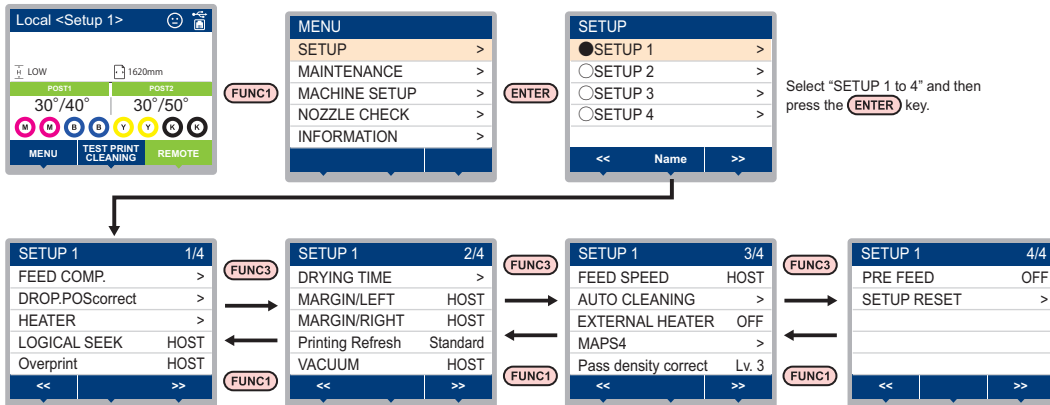

SETUP MENU table



- For each setting item below, you can set it so that the machine may operate according to the value specified when you printed from your RIP software in the connected host PC.
- **Set Item** : LOGICAL SEEK/ Overprint/ DRYING TIME/ MARGIN (LEFT and RIGHT)/ VACUUM FAN/ FEED SPEED
- When you operate the machine according to the contents specified with the RIP software, set each item to "Host" when registering this machine type. When you set it other than "Host", the machine operates according to the machine setup.
- For the specifying method with the RIP software, refer to the operation manual of the RIP software.

Function name	Set value	When no instruction from RIP exists *1	Outline
FEED COMP. (☞ P.3-4)	-9999 to <u>0</u> to 9999	_____	Used to print a pattern for correcting a media-feeding rate and correct it.
	Each Print Cond. (☞ P.3-5)	ON/ OFF -255 to <u>0</u> to 255	You can perform feed correction and apply correction values for each print mode having different feed conditions.
DROP.POScorrect (☞ P.3-5)	-40.0 to <u>0</u> to 40.0	_____	Used to adjust the dot position in go and return printing.

Function name		Set value	When no instruction from RIP exists *1	Outline
HEATER (☞ P.3-6)	POST1	20 to 50 °C (68 to 122°F)/OFF	————	Sets each heater's conditions.
	POST2	20 to 60 °C (68 to 140°F)/OFF		
	OFF TIME	NONE/ 0 to 90 min		Set the time from the print completion until the heater to be OFF.
LOGICAL SEEK (☞ P.3-6)		<u>HOST</u> /ON / OFF	OFF	Sets the scan movable area during printing.
Overprint (☞ P.3-6)		<u>HOST</u> / 1 to 9	1	Sets the number of layers in which ink is to be applied.
DRYING TIME (☞ P.3-7)	SCAN	<u>HOST</u> / 0.0 to 9.9 sec	0 sec	Sets the time to wait for ink drying.
	PRINT END	<u>HOST</u> / 0 to 120 min	0 min	
MARGIN/LEFT (☞ P.3-7)	<u>HOST</u> / -10 to 85 mm		0 mm	Sets a non-printing area along the right and left edges of the media.
MARGIN/RIGHT (☞ P.3-7)			0 mm	
Printing Refresh		Weak / Standard / Strong	————	Set the refresh level during printing.
VACUUM (☞ P.3-8)		HOST/ WEAK/ STANDARD/ STRONG	WEAK	Sets the absorbability of the media.
FEED SPEED *2 (☞ P.3-8)		<u>HOST</u> / 10 to 200%	100%	Changes the media feeding speed in printing.
AUTO CLEANING (☞ P.3-8)	OFF, FILE, LENGTH, TIME		————	Sets the automatic cleaning operation for the head performed before printing or during printing.
	FILE INTERVAL TYPE	1 to 1000	————	
		NORMAL/ SOFT/ HARD	————	
	LENGTH INTERVAL TYPE	0.1 to 100.0m	————	
		NORMAL/ SOFT/ HARD	————	
	TIME INTERVAL TYPE	10 to 120 min	————	
NORMAL/ SOFT/ HARD		————		
Cleaning Check		ON/ OFF	————	Set to run or not a nozzle check after auto cleaning.
EXTERNAL HEATER (☞ P.3-9)		ON/ OFF	————	Used to set external heater to ON/OFF.
MAPS4 (☞ P.3-9)	AUTO	MAPS MODE	image quality priority / Speed priority	Perform setting to reduce stripes between passes.
	MANU AL	SPEED	50 to <u>95</u> %	
		Smoothing Lv.	0 to <u>25</u> to 100%	
Pass density correct (☞ P.3-10)		<u>OFF</u> / Weak / Mid / Strong		If periodic pass density differences are noticeable between passes, it can be reduced by changing this setting.
Pre-feed (☞ P.3-10)		<u>OFF</u> / 100 to 500 mm	————	In order to prevent sticking and wrinkles of the media, set the media length to feed back and forth before printing.
RESET SETTING (☞ P.3-4)		The configuration in the settings 1-4 can be reset individually.		

*1. This is the setting value to be used for printing when setting value is not specified at the RIP software (host) side, or, you give priority to the setting value at the machine side.

*2. When you set this to "100%" or more, required time for completion of printing will be shortened. However, enough drying time cannot be ensured and it may affect the image quality.

Register the optimal print conditions to match the use

In this machine, you will be able to register print conditions, SETUP 1 to 4 individually to match the media in advance.

For example, after print on different types of media, return to the media always use. In such case you can set the optimum printing conditions by simply selecting the registered SETUP 1 to 4.



- Print conditions that can be pre-registered with the machine are the four types, "SETUP 1" to "SETUP 4".

Register the print conditions to SETUP 1 to 4

1 Press **FUNC1** (MENU) → **ENTER** in LOCAL.

2 Press **▲▼** to select SETUP 1 to 4, and press the **ENTER** key.

- The item selected indicates ● and others show ○.
- SETUP MENU will be displayed.

3 Press **▲▼** to select and set each item in the setup menu list.

- Please see the reference page in the setup menu list for detailed configuration procedure.

Reset the registered contents

Reset the contents registered to SETUP 1 to 4.

1 Press **FUNC1** (MENU) → **ENTER** in LOCAL.

2 Press **▲▼** to select SETUP 1 to 4 to be reset and press the **ENTER** key.

- SETUP MENU will be displayed.

3 Press **FUNC1** (<<).

4 Press **▲▼** to select "RESET SETTING", and press the **ENTER** key.

- Confirmation screen of reset settings will be displayed.

5 Press the **END/POWER** key several times to end the setting.

Setting of Media Correction

Correct the media feed amount to match the type of media you are using.

If the correction value is not appropriate, stripes may appear on the printed image, thus resulting in a poor printing.



- On completion of [MEDIA COMP.] during use of a roll media, the media returns to the printing origin. Then the roll media in the rear of this machine will slacken. Before printing, take up the slack in the roll media by hand; a loose roll media can result in an inferior image quality.
- When printing with a take-up device, set the media first and then perform media correction.

A pattern for media correction is printed and a media-feeding rate is corrected.



- Two bands are printed in the correction pattern.
- Make adjustment so that an even color density is obtained in the boundary between the two bands.

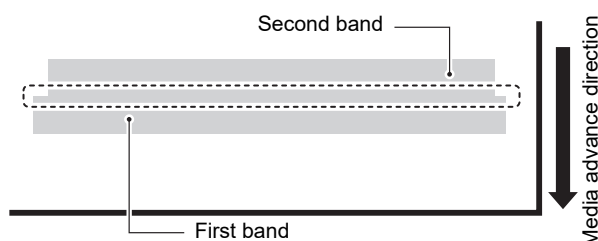

1 Set a media. (☞ P.2-4)

2 Press **FUNC1** (MENU) → **ENTER** in LOCAL.

3 Press **▲▼** to select SETUP 1 to 4, and press the **ENTER** key.

- SETUP MENU will be displayed.

4 Press **▲▼** to select "FEED COMP", and press the **ENTER** key.

5 Press the **ENTER** key twice to print a correction pattern.

6 Check the correction pattern and enter a correction value.

- A screen for entering the correction value will be displayed.
- Enter a correction value in "+": The boundary between the two bands is widened.
- Enter a correction value in "-": The boundary between the two bands is narrowed.
- When you change the correction value by "30", the width of the boundary changes by about 0.1 mm.

7 Press the **ENTER** key.

- Print a correction pattern again and check it.
- When media correction is needed, perform the operation in Step 7 to make correction.

8 Press the **END/POWER** key several times to end the setting.

Correcting Media-feeding during Printing

A media-feeding rate can be corrected even in the remote mode or when image data is printed.

- 1** Press **[FUNC1] (ADJUST) → [ENTER]** in the Remote.
- 2** Press **[▲] [▼]** to enter a corrected feeding rate.
 - Corrected feeding rate: -9999 to 9999
 - The value entered here is reflected in the corrected feeding rate soon.
- 3** Press the **[ENTER]** key twice.
 - key. The changed value is registered.
 - When you press the [ENTER] key instead of the [END] key, the value entered here will be valid temporarily. (When you perform media detection again or turn the power OFF, the correction value is cleared.)

Feed Comp by print condition

Conditions such as feed speed differ depending on the print mode.

By providing the correction value according to each mode, it is possible to reduce the work of changing correction values when outputting different print modes within the same setting.

- 1** Set the media. (☞P.2-4)
 - 2** Press **[FUNC1] (MENU) → [ENTER]** in LOCAL.
 - 3** Press **[▲] [▼]** to select settings 1 to 4, and press the **[ENTER]** key.
 - The setting menu is displayed.
 - 4** Press **[▲] [▼]** to select "Feed Comp.", and press the **[ENTER]** key.
 - 5** Press **[FUNC1] (MENU)** on the screen waiting for "Print Start" to switch ON / OFF.
 - When ON:
 - You can correct for each condition and enter the correction value.
 - Each correction value is applied according to the printing conditions.
 - (1) 480x600 1, 2 pass (1 pass is 4 color set only)
 - (2) 600x600 1, 2 pass (1 pass is 4 color set only)
 - (3) Others
 - The print mode except for (1) and (2) is 720x600, 600x1200 all pass.
 - When OFF:
 - One correction value is applied to all modes.
 - You can check all correction values by pressing [FUNC3].
- !** If the advanced setting is set to "ON", perform adjustment in all modes used.

If the Positions of Dots Shift...

When the condition for printing (media thickness/ink type/ etc.) has been changed, perform the following operation to correct the ink drop position for bidirectional (Bi) printing and obtain the proper printing result.

Example of a Printed Pattern

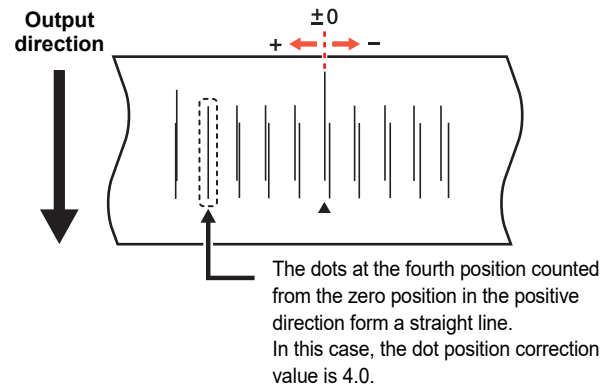

- 1** Set a media on the machine. (☞P.2-4)
 - In order to print a pattern, a media that is 500 mm wide at least is necessary.
- 2** Press **[FUNC1] (MENU) → [ENTER]** in LOCAL.
- 3** Press **[▲] [▼]** to select SETUP 1 to 4, and press the **[ENTER]** key.
 - SETUP MENU will be displayed.
- 4** Press **[▲] [▼]** to select "DROP.POS correct", and press the **[ENTER]** key.
- 5** Press the **[ENTER]** key.
 - Start the pattern printing.
 - Multiple test patterns are printed. (The printed patterns are called Pattern 1, Pattern 2, Pattern 3... in the order of printing.)
- 6** Press **[▲] [▼]** to enter a correction value of Pattern 1, and press the **[ENTER]** key.
 - Corrected feeding rate: -40 to 40
 - Check the test patterns. The position where an outward feeding line and a return feeding line become one straight line is the correction value.
 - When the correction value is not between -40 and 40, adjust the height of the printing heads and then perform the operations in Step 2 and later.
- 7** In the same way as in Step 4, enter a correction value of Pattern 2 and later, and press the **[ENTER]** key.
- 8** Press the **[END/POWER]** key several times to end the setting.

Setting the HEATER

Post-heater 1 and Post-heater 2 are equipped on the after-heater.

Type of HEATER	Function
POST1	This is a preheater to prevent a rapid rise in the temperature of the media.
POST2	This is a heater to dry the printed ink on the media.

Here, in addition to the temperature setting of each heater, the time from the print completion until the heater to be OFF can be set up.

- 1** Press **(FUNC1)** (MENU) → **(ENTER)** in LOCAL.
- 2** Press **(▲)****(▼)** to select **SETUP 1** to **4**, and press the **(ENTER)** key.
 - SETUP MENU will be displayed.
- 3** Press **(▲)****(▼)** to select **"HEATER"**, and press the **(ENTER)** key.
- 4** Set each heater temperature by pressing **(▲)****(▼)**.
 - Heater selecting : Select by **(▲)****(▼)** and press the **(ENTER)** key
 - Temperature setting : Set by **(▲)****(▼)**
 - Temperature setting of each heater
 POST 1:20 ~ 50°C
 POST 2:20 ~ 60°C
- 5** Press **(▲)****(▼)** to select **"OFFTIME"**, and press the **(ENTER)** key.
- 6** Press **(▲)****(▼)**, set the time until the heater to be OFF after printing, and press the **(ENTER)** key.
 - Set value: NONE / 0 to 90 min
- 7** Press the **(END/POWER)** key several times to end the setting.



- Depending on the usage environment, the temperature on the screen on POST 1 side may decrease.

Setting of Logical Seek

The head's operation varies depending on the LOGICAL SEEK settings, as shown in the figure below.

Movement of heads when LOGICAL seek is OFF

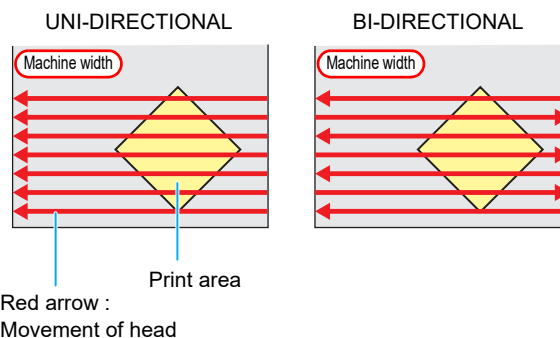

Movement of heads when LOGICAL seek is ON

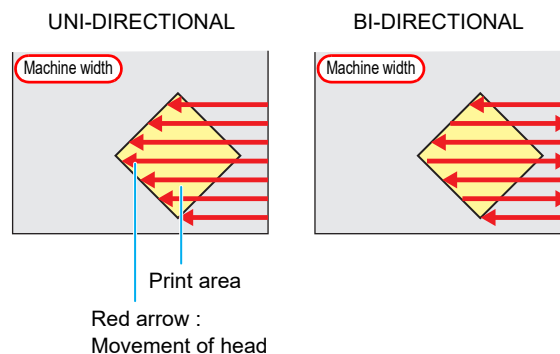

- 1** Press **(FUNC1)** (MENU) → **(ENTER)** in LOCAL.
- 2** Press **(▲)****(▼)** to select **SETUP 1** to **4**, and press the **(ENTER)** key.
 - SETUP MENU will be displayed.
- 3** Press **(▲)****(▼)** to select **"LOGICAL SEEK"**, and press the **(ENTER)** key.
- 4** Press **(▲)****(▼)** to select a set value, and press the **(ENTER)** key.
 - Set value : HOST / ON / OFF
- 5** Press the **(END/POWER)** key several times to end the setting.

Setting of Overprint

Sets the number of layers in which ink is to be applied.

- 1** Press **(FUNC1)** (MENU) → **(ENTER)** in LOCAL.
- 2** Press **(▲)****(▼)** to select **SETUP 1** to **4**, and press the **(ENTER)** key.
 - SETUP MENU will be displayed.
- 3** Press **(FUNC3)** (>>).

4 Press to select "Overprint", and press the key.

5 Press to set number of Overprint, and press the key.
 • Setting value : Host/ 1 to 9 times

6 Press the key several times to end the setting.

Setting of Drying Time

In the drying time setting, the following items for ink drying time are set.

- **SCAN** : Ink drying time for each scanning is set. (During bidirectional printing, the machine stops for a certain period of time specified for each of the outward and return scanning.)
- **PRINT END** : Ink drying time after printing has been complete is set.



- When you give priority to the setting at the RasterLink side, make the setting value "Host".
- "SCAN" set in this machine is displayed as "Pause Time per Scan" in the RasterLink.
- You cannot specify the print end at the RasterLink side. When you set this machine to "Host", printing will be performed in "PRINT END= 0 min." status.

1 Press in LOCAL.

2 Press to select SETUP 1 to 4, and press the key.
 • SETUP MENU will be displayed.

3 Press .

4 Press to select "DRYING TIME", and press the key.

5 Press the key.

6 Press to set drying time, and press the key.

- Set the drying time for canning and after printing is completed. To enable the drying time specified in your RIP, select "Host".
- **Scanning setting value** : Host or 0.0 sec. to 9.9 sec.
- **Print end setting value** : Host or 0 sec. to 120 minute.
- **Item selecting** : by the keys
- **Time setting** : by the keys

7 Press the key several times to end the setting.

Setting of Left and Right Margins

Set a non-printing area along the left and right edges of the media.

The offset value against the standard margin 15 mm is set hereupon.



- When you give priority to the setting at the RIP software side, make the setting value "Host".
- You cannot specify the margins at the attached RIP software (RasterLink). When you use the RasterLink, if you set this machine to "Host", printing will be performed in "Margins for right and left off set value= 0 mm" status.
- The margin setting is reflected when the media width is detected.

1 Press in LOCAL.

2 Press to select SETUP 1 to 4, and press the key.
 • SETUP MENU will be displayed.

3 Press .

4 Press to select "Margin/L" or "Margin/R", and press the key.

5 Press to select a set value, and press the key.
 • Set value : HOST / -10 to 85 mm

6 Press the key several times to end the setting.



- Pay attention to that printing may start on the media press if a right and left margin is set to 5 mm or less when the media press is used in printing.

Printing Refresh

You can change the refresh level during printing.



- For data with a small amount of ink, the possibility of nozzle cloggings increases at the refresh level of "weak".

1 Press in LOCAL.

2 Press to select SETUP 1 to 4, and press the key.
 • SETUP MENU will be displayed.

3 Press .

4 Press to select "Printing Refresh", and press the key.

5 Press to change "Refresh Level", and press the key.
 • Set value : Weak / Standard / Strong

Setting of Vacuum Fan

Sets the absorbability of the media.

By setting the absorption power to match the media, you can prevent print errors due to media rise-up.

- 1 Press **FUNC1 (MENU)** → **ENTER** in LOCAL.
- 2 Press **▲▼** to select **SETUP 1 to 4**, and press the **ENTER** key.
 - SETUP MENU will be displayed.
- 3 Press **FUNC3 (>>)**.
- 4 Press **▲▼** to select **"VACUUM FAN"**, and press the **ENTER** key.
- 5 Press **▲▼** to select a set value, and press the **ENTER** key.
 - Set value : HOST/WEAK /STANDARD/ STRONG
- 6 Press the **END/POWER** key several times to end the setting.

Suction fan always on

If you leave the suction fan off, the media may be distorted or lifted, causing media jam during the next cap-off operation.

By leaving the suction fan on after printing or jog operation, it is possible to prevent the media from being distorted or lifted.

- 1 In local mode, press **FUNC2 (TEST PRINT / CLEANING)** and press the **ENTER** key.
 - The "MAINTENANCE" screen is displayed.
- 2 Press **▲▼** to select **"Vacuum Cont. Running"**.
- 3 Press the **ENTER** key to select **ON/OFF**.
 - Setting value: ON / OFF
 - **ON** : The suction fan operates immediately after setting.
Even after the cap OFF operation (printing, station maintenance, jog operation, etc.) is completed, the suction fan remains in operation.
The strength for sucking the media follows the user setting (MENU> SET UP> VACUUM FAN).
 - **OFF** : Stops the suction fan operation.
- 4 Press the **END/POWER** key several times to end the setting.

Setting of Feed Speed

Changes the media feeding speed in printing.

- 1 Press **FUNC1 (MENU)** → **ENTER** key in LOCAL.
- 2 Press **▲▼** to select **SETUP 1 to 4**, and press the **ENTER** key.
 - SETUP MENU will be displayed.
- 3 Press **FUNC3 (>>)** twice.
- 4 Press **▲▼** to select **"FEED SPEED"**, and press the **ENTER** key.
- 5 Press **▲▼** to select a set value, and press the **ENTER** key.
 - Set value : HOST / 10 to 200%
- 6 Press the **END/POWER** key several times to end the setting.



- Some speed is not changed according to a setting condition.
- The media feed speed during printing is decided by this setting and the set value in [Setting of Feed Quality].

Setting Auto Cleaning

You can set the machine so that it counts the number of printed files or the length or time after printing has been completed, and performs cleaning automatically if required. You can select the auto cleaning setting from three types below:

- **PAGE** : Set the cleaning intervals by the number of printed files.
- **LENGTH** : Set the cleaning intervals by the printed length.
- **TIME** : Set the cleaning intervals by the printed time.

Besides, automatic nozzle check after auto cleaning can be set. (Cleaning Check function)

The machine can perform a stable printing operation with its heads always kept clean.

- 1 Press **FUNC1 (MENU)** → **ENTER** in LOCAL.
- 2 Press **▲▼** to select **SETUP 1 to 4**, and press the **ENTER** key.
 - SETUP MENU will be displayed.
- 3 Press **FUNC3 (>>)** twice.
- 4 Press **▲▼** to select **"AUTO CLEANING"**, and press the **ENTER** key.
- 5 Press the **ENTER** key, and press **▲▼** to select the type of auto cleaning.
 - There are "FILE", "LENGTH" and "TIME" for auto cleaning.

- FILE:** When the set number of prints has been completed, the machine performs head cleaning automatically.
- LENGTH:** When the set length has passed, the machine performs head cleaning automatically.
- TIME:** When the set time has passed, the machine performs head cleaning automatically.

- If you do not set auto cleaning, first select "OFF" and then proceed to the Step 10.

6 Press **ENTER**, and press **▲▼** to select the cleaning interval.

- Depending on the auto cleaning type selected in the Step 5, the setting value differs.

For **FILE:** 1 to 1000 file

For **LENGTH:** 0.1 to 100.0m (in 0.1m increment)

For **TIME:** 10 to 120min (in 10min increment)

7 Press the **ENTER** key, and press **▲▼** to select the cleaning type.

- Set Value : NORMAL/ SOFT/HARD

8 Press the **ENTER** key, and press **▲▼** to select "Cleaning Check".

9 Press the **ENTER** key, and press **▲▼** to select set value.

- Set Value : ON/ OFF

10 Press the **ENTER** key.

11 Press the **END/POWER** key several times to end the setting.



- Depending on the state of the heads, etc., the image quality deterioration may not be improved even with this function performed. In this case, contact our service office or the distributor in your region.

Setting External heater

Used to set external heater to ON/OFF.

1 Press **FUNC1** (MENU) **➔** **ENTER** in LOCAL.

2 Press **▲▼** to select SETUP 1 to 4, and press the **ENTER** key.

- SETUP MENU will be displayed.

3 Press **FUNC1** (<<).

4 Press **▲▼** to select "EXTERNAL HEATER", and press the **ENTER** key.

5 Press **▲▼** to select set value.

- Set Value: ON/OFF

6 Press the **ENTER** key.

7 Press the **END/POWER** key several times to end the setting.

Setting of MAPS4

The MAPS (Mimaki Advanced PassSystem) function to disperse the pass boundary to make the feeding stripes less visible.



- Changing the MAPS4 settings may change the color tone. Check the effects before use.
- MAPS may not be effective depending on image to be printed. Use it after checking effect in advance.

● Conditions disabling MAPS function

The MAPS function may be disabled under the following conditions. In addition, the MAPS may not be effective, depending on the image to be printed.

4-colors ink set

Resolution	Pass	MAPS MODE
480 x 600	1 pass	Speed priority
600 x 600	1 pass	

6-colors, 7-colors, 8-colors ink set

Resolution	Pass	MAPS MODE
480 x 600	2 pass	—
600 x 600	2 pass	

Setting MAPS4 Function (AUTO)

1 Press **FUNC1** (MENU) **➔** **ENTER** in LOCAL.

2 Press **▲▼** to select SETUP 1 to 4, and press the **ENTER** key.

- SETUP MENU will be displayed.

3 Press **FUNC3** (>>) twice.

4 Press **▲▼** to select "MAPS4", and press the **ENTER** key.

5 Press **▲▼** to select "AUTO", and press the **ENTER** key.

- To select "MANUAL" for the setting, refer to P.3-10 "Setting MAPS4 Function (MANUAL)".
- "AUTO" setting is recommended.

6 Press **▲▼** to select the print mode (Speed priority / image quality priority) for 1-pass printing, then press the **ENTER** key.



- Prints that are not 1 pass do not matter.
- Speed priority: Prints 1 pass with speed priority.
- Image quality priority: Prints 1 pass with image quality priority.

- 7** Press the **END/POWER** key several times to end the setting.

Setting MAPS4 Function (MANUAL)

- 1** Press **FUNC1** (MENU) → **ENTER** in LOCAL.

- 2** Press **▲▼** to select SETUP 1 to 4, and press the **ENTER** key.
• SETUP MENU will be displayed.

- 3** Press **FUNC3** (>>) twice.

- 4** Press **▲▼** to select "MAPS4", and press the **ENTER** key.

- 5** Press **▲▼** to select "MANUAL", and press the **ENTER** key.

- To select "AUTO" for the setting, refer to P.3-9 "Setting MAPS4 Function (AUTO)".

- 6** Press **▲▼** to select the "SPEED" (50 to 95%), and press the **ENTER** key.

- Select a speed for printing. By using standard quality printing as reference, set in the direction of minus (-) to decrease the print speed, and set in the direction of plus (+) to increase the print speed.



- If the speed is changed, NOZZLE RECOVERY (P.3-26) may not become effective. Check in advance before use.

- 7** Press **▲▼** to select the "Smoothing Lv.", and press the **ENTER** key.

- 8** Press **▲▼** to change the smoothing level, and press the **ENTER** key.



- For 2-pass printing, the smoothing level is 100% regardless of the "MANUAL" setting.

- Set Value : 0 to 100% (set in units of 5%)
• The MAPS4 effect become strong as the set value increase, and become weak as the set value decrease.

- 9** Press the **END/POWER** key several times to end the setting.

Pass density correct

If periodic shading differences are noticeable between passes, it can be reduced by changing this setting.



- A fixed correction is applied in the initial state (Lv 3). Change this if you can see differences in density in the initial state.

- 1** Press **FUNC1** (MENU) → **ENTER** in LOCAL.

- 2** Press **▲▼** to select SETUP 1 to 4, and press the **ENTER** key.

- The setting menu is displayed.

- 3** Press **FUNC3** (>>) twice.

- 4** Press **▲▼** to select "Pass density correct" and press the **ENTER** key.

- 5** Press **▲▼** to change the correction value, and press the **ENTER** key.

- Set Value: OFF/ Weak / Mid / Strong

- 6** Press the **END/POWER** key several times to finish.

Setting Pre-feed

The following effects can be expected by feeding back and forth the media before printing.

- Prevent media from sticking to the various rollers and the platen of this machine.
- If the wrinkle is shifted to the media, wrinkle reduction can be expected.

- 1** Press **FUNC1** (MENU) → **ENTER** in LOCAL.

- 2** Press **▲▼** to select SETUP 1 to 4, and press the **ENTER** key.

- SETUP MENU will be displayed.

- 3** Press **FUNC3** (>>) twice.

- 4** Press **▲▼** to select "Pre-Feed", and press the **ENTER** key.

- 5** Press **▲▼** to set the feeding media lengths.

- Set Value : OFF, 100 to 500 mm
• When [OFF] is set, pre-feed is not executed.

- 6** Press the **ENTER** key.

- 7** Press the **END/POWER** key several times to end the setting.

Change of setting type name

You can change the name of the setting type.



- The characters that can be used are alphanumeric characters and symbols.

- 1** Press **FUNC1** (MENU) → **ENTER** in LOCAL.

- 2** Press **▲▼** to select the setting 1 to 4, then press the **FUNC2** (Name) key.

- SETUP MENU will be displayed.

3 Change the setting type name.

4 Press the **END/POWER** key several times to end the setting.

About MACHINE SETUP MENU

Common settings are functions for using this machine easily.
The following items can be set in machine setups.

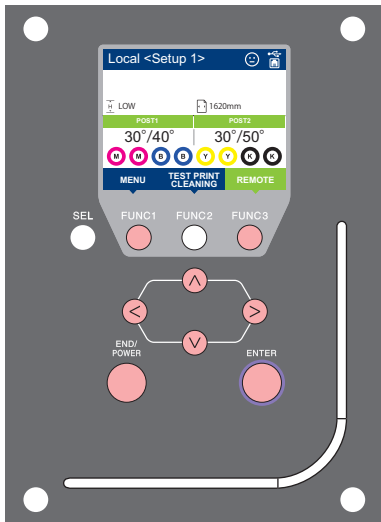

- (FUNC1)** : Press this to select MACHINE SETUP MENU, or to switch to the previous screen.
- (FUNC3)** : Press this to switch to the next screen.
- (▲) (▼)** : Use these to select a setting item.
- (ENTER)** : Press this to confirm a setting, etc.

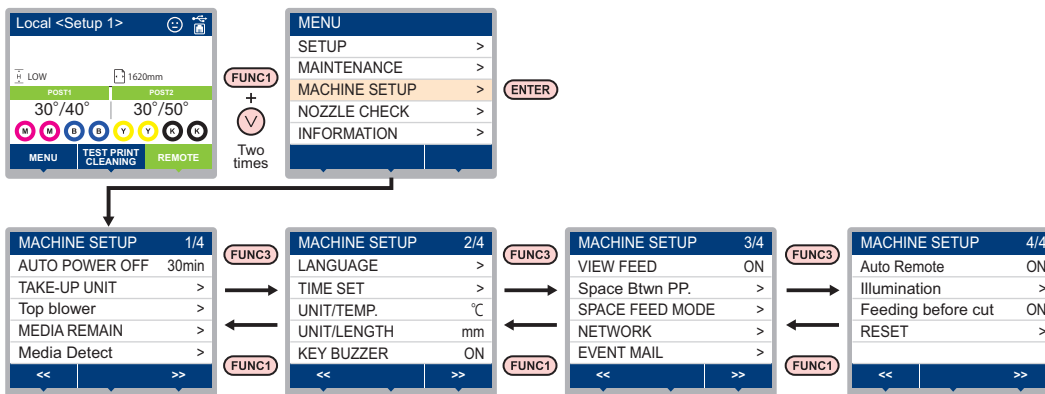

◆ MACHINE SETUP MENUS at-a-glance



MACHINE SETUP MENU table

Function name	Set value	Meaning	
AUTO Power-off (☞ P.3-15)	NONE/ 10 ~ <u>30</u> ~ 600min	When no operation has been performed for the set time, the power supply is automatically turned "OFF".	
TAKE-UP UNIT (☞ P.3-15)	Sub take-up unit	<u>ON</u> / OFF	Set whether or not to use sub take-up unit.
	Sub take-up SW	ON/ <u>OFF</u>	Sets the operation method when pressing the ON / OFF button of the sub take-up unit.
Top blower (☞ P.3-15)	ON	<u>AUTO</u> / STORONG/ WEAK	Set the operation of the top blower in print.
	OFF		
MEDIA REMAIN (☞ P.3-15)	ON/ <u>OFF</u>	You can control the remaining amount of media.	
Media Detect (☞ P.3-16)	At Startup	ON/ <u>OFF</u>	Set whether or not to detect media at the machine startup.
	Detect Speed	<u>High</u> / Normal	Set the media detection speed.
LANGUAGE (☞ P.3-16)	日本語 / <u>English</u> / 中文 /Turkce	Displayed language is changed.	
TIME SET (☞ P.3-16)	+4h ~ -20h (Japan time)	Time difference is corrected.	
UNIT/ TEMP. (☞ P.3-17)	<u>°C</u> (Centigrade)/°F (Fahrenheit)	A unit for displaying temperature is set.	
UNIT/ LENGTH (☞ P.3-17)	<u>mm</u> / inch	A unit for displaying length and area is set.	
KEY BUZZER (☞ P.3-17)	<u>ON</u> / OFF	A buzzer sound when keys are pressed is set.	

Function name		Set value		Meaning	
VIEW FEED (P.3-17)		ON / OFF		Set whether media feeding is performed for checking the result of the test printing etc. or not.	
Space Btwn PP. (P.3-17)		None/10 to 500 mm		Set whether media feeding is performed for checking the result of the test printing etc. or not.	
SPACE FEED MODE (P.3-17)		INTERMITTENT / CONTINUOUS		Change the feed mode of the margin included in the image data.	
NETWORK (P.3-18)	Set the network.				
	Check IP Addr.	The IP address currently used by this machine is displayed.			
	Check MAC Addr.	The IP address currently used by this machine is displayed.			
	DHCP	ON / OFF		When it is ON, the IP address given by the DHCP server is used.	
	AutoIP	ON / OFF		When it is ON, the IP address is determined by the AutoIP protocol. However, DHCP is ON, DHCP has priority.	
	IP Address *1	Set the IP address used by this machine.			
	Default Gateway *1	Set the default gateway used by this machine.			
	DNS Address *1	Set the DNS server address used by this machine.			
	SubNet Mask *1	Set the digit number of the subnet mask used by this machine.			
EVENT MAIL	Mail Delivery (P.3-19)	ON / OFF		Set whether you send/ do not send the e-mail when the set event occurs.	
	Select Event (P.3-19)	Print Start Event	ON / OFF	Set whether you send/ do not send the e-mail at the start of printing.	
		Print End Event	ON / OFF	Set whether you send/ do not send the e-mail at the end of printing.	
		Plot Start Event	ON / OFF	Set whether you send/ do not send the e-mail at the start of plotting.	
		Plot End Event	ON / OFF	Set whether you send/ do not send the e-mail at the end of plotting.	
		Error Event	ON / OFF	Set whether you send/ do not send the e-mail when a error occurs.	
		Warning Event	ON / OFF	Set whether you send/ do not send the e-mail when a warning occurs.	
		Other Event	ON / OFF	Set whether you send/ do not send the e-mail when an event other than the above occurs.	
	Mail Address (P.3-19)	Set the e-mail address to which you send the event mail.		Alphanumeric characters and symbols (within 96 characters)	
	Message Subject (P.3-19)	Set the characters to write in the subject of the event mail.		Alphanumeric characters and symbols (within 8 characters)	
	Server Setup (P.3-20)	SMTP Address		Set the SMTP server.	
		SMTP Port No.		Set the SMTP port number.	
		SENDER ADDRESS		Set the e-mail address to be used as the sender mail address.	
		Authentication	POP before SMTP	Set the SMTP server authentication method (SMTP authentication).	
			SMTP Authentication		
OFF					
User Name *2		Set the user name used for the authentication.			
Pass Word *2		Set the password used for the authentication.			
POP3 Address *3		Set the POP server.			
APOP *3		Set ON/OFF of APOP.			
Transmit Test (P.3-21)	Send the test e-mail.				
Auto Remote (P.3-22)		ON / OFF		When data is received in the local mode, it automatically switches to the remote mode and sets whether to start printing.	

Function name		Set value	Meaning
Illumination ( P.3-22)	Lighting Up Type	<u>A</u> uto / Manual	Set the lighting / extinguishing method for printing operation and maintenance work (cover open etc).
	Lighting Up Extention	None / 1~ <u>5</u> ~10min	When "Auto" is selected, set the time to continue lighting etc. after printing operation.
	Start Up Lighting	ON / <u>O</u> FF	Set whether to turn ON / OFF at the time of unit startup.
Feeding before cut ( P.3-22)		<u>O</u> N / OFF	You can disable the media feed operation at the time of media cut execution.
RESET ( P.3-22)			All setting values are returned to the status default.

*1. Settable when both of DHCP and AutoIP are [OFF]

*2. Settable only when Auth. is not OFF

*3. Settable only when Auth. is POP before SMTP

Setting a AUTO Power-off

When no operation has been performed for the set time, the power supply is automatically turned "OFF".

- 1 Press **FUNC1 (MENU)** → **▼** (twice) → **ENTER** in LOCAL.
 - MACHINE SETUP MENU will be displayed.
- 2 Press **▲▼** to select "AUTO POWER OFF", and press the **ENTER** key.
- 3 Press **▲▼** to select a set value, and press the **ENTER** key.
 - Set Value : none, 10 to 600min
- 4 Press the **END/POWER** key several times to end the setting.

Setting Take-up unit

For the "TAKE-UP UNIT" settings, set the following items:

- Use / do not use sub take-up unit.
- Operation when pressing ON/OFF button of sub take-up unit.

- 1 Press **FUNC1 (MENU)** → **▼** (twice) → **ENTER** in LOCAL.
 - MACHINE SETUP MENU will be displayed.
- 2 Press **▲▼** to select "TAKE-UP UNIT", and press the **ENTER** key.
- 3 Press **▲▼** to select "Sub Take-up Unit", and press the **ENTER** key.
- 4 Press the **ENTER** key.
 - "Sub Take-up Unit" will be selected.
- 5 Press **▲▼** to select a set value, and press the **ENTER** key.
 - Set Value : ON / OFF
- 6 Press **▼**, and press the **ENTER** key.
 - "Sub Take-up SW" will be selected.
- 7 Press **▲▼** to select a set value, and press the **ENTER** key.
 - Set Value : Continuance/ Temporary
 - Continuance :
Switching ON / OFF the winding operation when pressing the switch each time. (Take-up unit in operation does not stop until press again ON / OFF switch.)
 - Temporary :
Do the winding operation only while holding down the switch. (When release the switch, winding operation is stopped.)
- 8 Press the **END/POWER** key several times to end the setting.

Setting Top Blower

Set the operation of the top blower in print.

Turn the top blower setting "ON", and you can set the strength for the blower.

- 1 Press **FUNC1 (MENU)** → **▼** (twice) → **ENTER** in LOCAL.
 - MACHINE SETUP MENU will be displayed.
- 2 Press **▲▼** to select "Top blower", and press the **ENTER** key.
- 3 Press **▲▼** to select "ON", and press the **ENTER** key.
 - ON : You can choose the air volume of the blower.
 - OFF: The top blower does not work while printing process. Proceed to step 6.
- 4 Press **▲▼** to select "STRENGTH", and press the **ENTER** key.
- 5 Press **▲▼** to select a set value (AUTO/ STRONG/ WEAK), and press the **ENTER** key.
 - Set value : ON/ OFF
- 6 Press the **END/POWER** key several times to end the setting.

Setting the Display of Media Residual

Whether the screen displays the remaining amount of a media is set.

When the media remaining amount display is turned to "ON"	The remaining amount of a media is displayed in Remote.
When the media remaining amount display is turned to "OFF"	The remaining amount of a media is not displayed in the Remote.



- The amount of a media that has been fed by the printing and jog keys is reflected in the remaining amount of a media.
- The length of a media (initial value of the remaining amount) is entered when a roll media is detected. (P.2-9)
- The setting configured here does not become effective unless media detection is performed after the setting has been complete.

- 1 Press **FUNC1 (MENU)** → **▼** (twice) → **ENTER** in LOCAL.
 - MACHINE SETUP MENU will be displayed.
- 2 Press **▲▼** to select "MEDIA REMAIN", and press the **ENTER** key.
- 3 Press **▲▼** to select ON/OFF.
- 4 Press the **ENTER** key.

- 5** Press the **END/POWER** key several times to end the setting.



- When set "ON" the media remaining display, you can print the list of current media remaining amount and the date. (P.2-9)

Setting the Media Detection

Set the following two items in media detection settings.

At Startup	When set to "ON", media detection is performed automatically at the time of machine startup.
Detect Speed	Change the detection method. In case of "High", detection may fail, such as when there is print data on the medium passing through the detection sensor. Set it to "Normal", for example, when media detection fails or you do not want automatic detection of media presser.

Startup detection

- Press **FUNC1** (MENU) → **▼** (twice) → **ENTER** in LOCAL.
 - MACHINE SETUP MENU will be displayed.
- Press **FUNC3** (>>).
- Press **▲▼** to select "Media Detect", and press the **ENTER** key.
- Press **▲▼** to select "At Startup", and press the **ENTER** key.
- Press **▲▼** to select "ON / OFF", then press the **ENTER** key.
 - Set Value : ON / OFF
 - ON : Detect at startup
 - OFF : Not detect at startup
- Press the **END/POWER** key several times to end the setting.

Set the Detect Speed

- Press **FUNC1** (MENU) → **▼** (twice) → **ENTER** in LOCAL.
 - MACHINE SETUP MENU will be displayed.
- Press **FUNC3** (>>).
- Press **▲▼** to select "Media Detect", and press the **ENTER** key.
- Press **▲▼** to select "Detect Speed", and press the **ENTER** key.

- 5** Press **▲▼** to select "High / Normal", and press the **ENTER** key.

- Set value: High / Normal
- High: Media retainer auto detection is provided
- Normal: No media retainer auto detection



- When "High" is selected, detection may fail, such as when there is print data on the media passing through the detection sensor.
- If media detection fails or you do not want automatic detection of media retainer, select "Normal".

- 6** Press the **END/POWER** key several times to end the setting.

Setting a LANGUAGE

You can change the displayed language.

- Press **FUNC1** (MENU) → **▼** (twice) → **ENTER** in LOCAL.
 - MACHINE SETUP MENU will be displayed.
- Press **FUNC3** (>>).
- Press **▲▼** to select "LANGUAGE", and press the **ENTER** key.
- Press **▲▼** to select language, and press the **ENTER** key.
- Press the **END/POWER** key several times to end the setting.

Setting a Time

You can set time of your country (time difference).

- Press **FUNC1** (MENU) → **▼** (twice) → **ENTER** in LOCAL.
 - MACHINE SETUP MENU will be displayed.
- Press **FUNC3** (>>).
- Press **▲▼** to select "TIME", and press the **ENTER** key.
- Press **▲▼◀▶** to enter time, and press the **ENTER** key.
 - Year/Month/Day/Time selecting: by the [**◀**][**▶**]
 - Year/Month/Day/Time inputting: by the [**▲**][**▼**]
- Press the **END/POWER** key several times to end the setting.



- 20 hours to +4 hours can be set.

Setting Unit (Temperature/ Length)

Units used by this machine are set.

- 1 Press **FUNC1** (MENU) → **▼** (twice) → **ENTER** in LOCAL.
• MACHINE SETUP MENU will be displayed.
- 2 Press **FUNC3** (>>).
- 3 Press **▲▼** to select "UNIT/TEMP." or "UNIT/LENGTH", and press the **ENTER** key.
- 4 Press **▲▼** to select a set value, and press the **ENTER** key.
• Set value of temperture : °C / °F
• Set value of length : mm / inch
- 5 Press the **END/POWER** key several times to end the setting.

Setting a KEY BUZZER

You can turn off the buzzer sound when pressing the key.

- 1 Press **FUNC1** (MENU) → **▼** (twice) → **ENTER** in LOCAL.
• MACHINE SETUP MENU will be displayed.
- 2 Press **FUNC3** (>>) twice.
- 3 Press **▲▼** to select "KEY BUZZER", and press the **ENTER** key.
- 4 Press **▲▼** to select a set value, and press the **ENTER** key.
• Set value : ON/ OFF
- 5 Press the **END/POWER** key several times to end the setting.



- When the key buzzer is set to "OFF", the buzzer sound for errors, warnings, operation completion, etc. cannot be shut off.

Setting the VIEW FEED

Set whether media feeding is performed for checking the result of the test printing etc. or not.

- 1 Press **FUNC1** (MENU) → **▼** (twice) → **ENTER** in LOCAL.
• MACHINE SETUP MENU will be displayed.
- 2 Press **FUNC3** (>>) twice.
- 3 Press **▲▼** to select "VIEW FEED", and press the **ENTER** key.

- 4 Press **▲▼** to select a set value, and press the **ENTER** key.

- Set value : ON/ OFF

- 5 Press the **END/POWER** key several times to end the setting.

Setting the space between prints

Set whether media feeding is performed for checking the result of the test printing etc. or not.

- 1 Press **FUNC1** (MENU) → **▼** (twice) → **ENTER** in LOCAL.
• MACHINE SETUP MENU will be displayed.
- 2 Press **FUNC3** (>>) twice.
- 3 Press **▲▼** to select "Space Btwn PP.", and press the **ENTER** key.
- 4 Press **▲▼** to select a set value, and press the **ENTER** key.
• Set value : None/10 to 500 mm
- 5 Press the **END/POWER** key several times to end the setting.



- If you set the direction to reduce the margin amount, perform backward feed at the end of printing. In that case, pay attention to the following points.
- The media tension at the time of the next print by the backward feed fluctuates and the feed amount of the medium may change. In such a case, rewind the media manually.
- If the data to be printed already has a margin, using this function will output "margin attached to data + amount of margin set by this machine" as margin.

Setting the SPACE FEED MODE

Change the feed mode of the margin included in the image data (the space of no data to be printed). If print data with much margin, set to "continuous", then the print time can be shorten.

- 1 Press the **FUNC1** (MENU) → **▼** (twice) → **ENTER** key in LOCAL.
• MACHINE SETUP MENU will be displayed.
- 2 Press **FUNC3** (>>) twice.
- 3 Press **▲▼** to select "SPACE FEED MODE", and press the **ENTER** key.

- 4** Press   to select a set value, and press the  key.

INTERMITTENT: Perform intermittent feed operation of the path division unit

CONTINUOUS: Feed the no data part at a time

- 5** Press the  key several times to end the setting.

Set the network

- 1** Press  (MENU)   (twice)  in LOCAL.

- MACHINE SETUP MENU will be displayed.

- 2** Press  (>>) twice.

- 3** Press   to select "NETWORK", and press the  key.

- 4** Press the  key.

- "CHECK IP ADDRESS" will be selected.
- The IP address currently used by this machine is displayed.
- When you have finished the check, press the [ENTER] key.



- After connecting with the network, it takes time until the IP address is determined. If the IP address has not been determined, "0.0.0.0" is displayed.

- 5** Press , and press the  key.

- "CHECK MAC ADDRESS" will be selected.
- The MAC address currently used by this machine is displayed.
- When you have finished the check, press the [ENTER] key.

- 6** Press , and press the  key.

- "DHCP" will be selected.

- 7** Press   to select a set value, and press the  key.



- **Set value** : ON/ OFF
- When it is ON, the IP address given by the DHCP server is used.

- 8** Press , and press the  key.

- "AutoIP" will be selected.

- 9** Press   to select a set value, and press the  key.

- **Set value** : ON/ OFF
- When it is ON, the IP address is determined by the AutoIP protocol. However, DHCP is ON, DHCP has priority.

- 10** Press , and press .

- "IP ADDRESS" will be selected.



- 11** Press   to select a set value, and press the  key.

- **Set value** : ON/ OFF

- Both of DHCP and AutoIP is OFF, you can set IP Address. For other than above, proceed to the Step 14.

- 12** Press .

- The setting items DEFAULT GATEWAY, DNS ADDRESS and SUBNET MASK will be displayed.
- Both of DHCP and AutoIP is OFF, you can set DEFAULT GATEWAY/ DNS ADDRESS/ SUBNET MASK. For other than above, proceed to the Step 14.

- 13** Press  several times to select setting item, and press the  key.

- 14** Press   to select a set value, and press the  key.

- 15** Press the  key several times to end the setting.



- To reflect network setting, once turn off the power supply and turn it on again.

Setting event mail function

Set the function to send e-mails to the set e-mail address when events such as cutting start/ end and stop due to an error.

- Disclaimer
- The customer is responsible for the communication fee for Internet communication such as e-mail notification.
- The notification by the event mail function may not be delivered due to Internet environment, failure of the device/ the power supply, etc. Mimaki has absolutely no responsibility for any damages or loss resulting from non-delivery or delays.



- You can use event mail function by connecting LAN to this machine. Please prepare for LAN cable connection beforehand.
- Not compatible with SSL communication.

Enable the event mail function

- 1 Press **FUNC1** (MENU) \rightarrow \downarrow (twice) \rightarrow **ENTER** in LOCAL.
 - MACHINE SETUP MENU will be displayed.
- 2 Press **FUNC1** (<<).
- 3 Press \uparrow \downarrow to select "EVENT MAIL", and press the **ENTER** key.
- 4 Press the **ENTER** key.
 - "MAIL DELIVERY" will be selected.
- 5 Press \uparrow \downarrow to select "ON", and press the **ENTER** key.
- 6 Press the **END/POWER** key several times to end the setting.

Set the event to send an event mail

- 1 Press **FUNC1** (MENU) \rightarrow \downarrow (twice) \rightarrow **ENTER** in LOCAL.
 - MACHINE SETUP MENU will be displayed.
- 2 Press **FUNC1** (<<).
- 3 Press \uparrow \downarrow to select "EVENT MAIL", and press the **ENTER** key.
- 4 Press \downarrow , and press the **ENTER** key.
 - "SELECT EVENT" will be selected.
- 5 Press \uparrow \downarrow to select the event, and press **FUNC2** (\checkmark).
 - After selecting the event, press [FUNC2] key and put a check in the check box. An email will be sent when the event whose box has been checked occurs.
 - To select multiple events, use [\blacktriangle][\blacktriangledown] to put the cursor over the events you want, and put a check in their boxes by pressing [FUNC2].

Event name	Outline
PRINT START	Sets sending/not sending of an email when printing starts.
PRINT END	Sets sending/not sending of an email when printing ends.
PLOT START EVENT	Sets sending/not sending of an email when plotting starts.
PLOT END EVENT	Sets sending/not sending of an email when plot ends.
ERROR	Sets sending/not sending of an email when printing is stopped due to occurrence of an error.
WARNING	Sets sending/not sending of an email when a warning occurs during printing.
etc.	Sets sending/not sending of an email when an event other than the above occurs.

- 6 Press the **END/POWER** key several times to end the setting.

Set the e-mail address

- 1 Press **FUNC1** (MENU) \rightarrow \downarrow (twice) \rightarrow **ENTER** in LOCAL.
 - MACHINE SETUP MENU will be displayed.
- 2 Press **FUNC1** (<<).
- 3 Press \uparrow \downarrow to select "EVENT MAIL", and press the **ENTER** key.
- 4 Press \downarrow twice, and press the **ENTER** key.
 - "MAIL ADDRESS" will be selected.
- 5 Press \uparrow \downarrow \leftarrow \rightarrow to set mail address, and press the **ENTER** key.
 - Set the e-mail address to which you send the event mail.
 - Set it with alphanumeric characters and symbols within 96 characters.
- 6 Press the **END/POWER** key several times to end the setting.

Set the subject

- 1 Press **FUNC1** (MENU) \rightarrow \downarrow (twice) \rightarrow **ENTER** in LOCAL.
 - MACHINE SETUP MENU will be displayed.
- 2 Press **FUNC1** (<<).
- 3 Press \uparrow \downarrow to select "EVENT MAIL", and press the **ENTER** key.
- 4 Press \downarrow 3 times, and press the **ENTER** key.
 - "MESSAGE SUBJECT" will be selected.
- 5 Press \uparrow \downarrow \leftarrow \rightarrow to set subject, and press the **ENTER** key.
 - Set the characters to write in the subject of the event mail.
 - Set it with alphanumeric characters and symbols within 8 characters.
- 6 Press the **END/POWER** key several times to end the setting.

Set the server

- 1** Press **FUNC1** (MENU) **▶** **▼** (twice) **▶** **ENTER** in LOCAL.
 - MACHINE SETUP MENU will be displayed.
 - 2** Press **FUNC1** (<<).
 - 3** Press **▲** **▼** to select "EVENT MAIL", and press the **ENTER** key.
 - 4** Press **▼** 4 times, and press the **ENTER** key.
 - "SERVER SETUP" will be selected.
 - 5** Press the **ENTER** key.
 - "SMTP ADDRESS" will be selected.
 - 6** Press **▲** **▼** **◀** **▶** to set SMTP Address, and press the **ENTER** key.
 - Press jog key [**▲**][**▼**][**◀**][**▶**] to set SMTP address.
 - Input the SMTP address name.
 - 7** Press **▼**, and press the **ENTER** key.
 - "SMTP PORT No." will be selected.
 - 8** Press **▲** **▼** to set SMTP Port No., and press the **ENTER** key.
 - Set the SMTP port number.
 - 9** Press **▼**, and press the **ENTER** key.
 - "SENDER ADDRESS" will be selected.
 - 10** Press **▲** **▼** **◀** **▶** to set SENDER ADDRESS, and press the **ENTER** key.
 - Press [**▲**][**▼**][**◀**][**▶**] and set the e-mail address to be used as the sender mail address.
 - Set it with alphanumeric characters and symbols within 64 characters.
-  • Depending on your server, if you do not set the e-mail address not supporting the account, sending/receiving e-mails may be unavailable.
- 11** Press **▼**, and press the **ENTER** key.
 - "AUTHENTICATION" will be selected.
 - 12** Press **▲** **▼** to set authentication method, and press the **ENTER** key.
 - Set the authentication method of the SMTP server.
 - When you select [OFF], proceed to the Step 20.
 - 13** Press **▼**, and press the **ENTER** key.
 - "USER NAME" will be selected.
 - 14** Press **▲** **▼** **◀** **▶** to set User Name, and press the **ENTER** key.
 - Press [**▲**][**▼**][**◀**][**▶**] to set the user name to use for the authentication.
 - Set it with alphanumeric characters and symbols within 30 characters.
 - 15** Press **▼**, and press the **ENTER** key.
 - "PASSWORD" will be selected.

- 16** Press **▲** **▼** **◀** **▶** to set Pass Word, and press the **ENTER** key.
 - Press [**▲**][**▼**][**◀**][**▶**] to set the password to use for the authentication.
 - Set it with alphanumeric characters and symbols within 15 characters.

 • On the password setting screen, you can only check the value that you are currently inputting.

 - When you select [POP before SMTP] in the Step 11, set the items in the Step 16 to 19.
- 17** Press **▼**, and press the **ENTER** key.
 - "POP3 ADDRESS" will be selected.
- 18** Press **▲** **▼** **◀** **▶** to set POP3 Address, and press the **ENTER** key.
 - Press [**▲**][**▼**][**◀**][**▶**] to set POP server.
 - Input the POP server name.
- 19** Press **▼**, and press the **ENTER** key.
 - "APOPOP" will be selected.
- 20** Press **▲** **▼** to set ON/ OFF, and press the **ENTER** key.
- 21** Press the **END/POWER** key several times to end the setting.

Send a test e-mail

- 1** Press **FUNC1** (MENU) \rightarrow \downarrow (twice) \rightarrow **ENTER** in LOCAL.
 - MACHINE SETUP MENU will be displayed.
- 2** Press **FUNC1** (<<).
- 3** Press \uparrow \downarrow to select "EVENT MAIL", and press the **ENTER** key.
- 4** Press **FUNC3** (>>) \rightarrow **ENTER** .
 - "TRANSMIT TEST" will be selected.

- 5** Press the **ENTER** key.
 - The sent result is displayed.
 - If sending test e-mail has failed, an error code is displayed.
Refer to the next page to solve the problem.

```
Transmit Test
Failed: 12345 :ent
```

Error code

- 6** Press the **END/POWER** key several times to end the setting.



- The sent result of the test e-mail is the result of e-mail sending process performed by this machine to the e-mail server. It does not indicate that the e-mail was received at the address.
- If the spam e-mail filter etc. has been set in the terminal in which e-mails are received, even if "Sending has been completed" is displayed, the e-mail cannot be received in some cases.
- If sending test e-mail has failed, the error code below is displayed.
- If the error cannot be solved, try again after a while.
- For the server setting etc., contact with the network administrator or the provider.

Error Code	The expected cause	Remedy
10	Network connection error	<ul style="list-style-type: none"> • Check that the machine is connected with the network. • Check that the machine IP address is correct. • Check that the machine is in the environment where DNS is available.
20	No valid e-mail address.	<ul style="list-style-type: none"> • Enter the correct e-mail address.
11003 11004	The POP server cannot be found. Or cannot access DNS server.	<ul style="list-style-type: none"> • Check the POP server address. • Check that the machine is in the environment where DNS is available.
11021	Cannot connect with the POP server.	<ul style="list-style-type: none"> • Check the POP server setting. • Check the firewall setting.
12010	An error returns from the POP server.	<ul style="list-style-type: none"> • Check the POP server setting.
13000	The POP authentication has failed.	<ul style="list-style-type: none"> • Check the user name and the password. • Check the APOP setting. • Confirm the authentication method.
10013 10014	The SMTP server cannot be found. Or cannot access DNS server.	<ul style="list-style-type: none"> • Check the SMTP server address. • Check that the machine is in the environment where DNS is available.
10021	Cannot connect with the SMTP server.	<ul style="list-style-type: none"> • Check the SMTP server setting. • Check the SMTP port number. • Check the firewall setting.
10*** 11*** 20*** 21***	An error returns from the SMTP server. Or, there was no response.	<ul style="list-style-type: none"> • Check the SMTP server setting. • Cannot communicate with a server that requires mandatory SSL communication. • Check protocol filter settings.
12***	It is invalid sender address.	<ul style="list-style-type: none"> • Check that the e-mail address supporting the account entered in the user name/ the password is set in SENDER ADDRESS.
13***	The e-mail address cannot be found. Or, it is invalid sender address.	<ul style="list-style-type: none"> • Check the e-mail address. • Even if there is a mistake in the e-mail address, this error cannot be detected in some cases. • Check that the e-mail address supporting the account entered in the user name/ the password is set in SENDER ADDRESS.
22000 22008	SMTP authentication error	<ul style="list-style-type: none"> • Confirm the authentication method.
23*** 24*** 25***	The SMTP authentication has failed.	<ul style="list-style-type: none"> • Check the user name and the password.

***** is the error code returned from the e-mail server.

Automatic remote

When data is received in local mode, it automatically switches to remote mode and starts printing.

- 1 Press **FUNC1** (MENU) → **▼** (twice) → **ENTER** in LOCAL.
 - MACHINE SETUP MENU will be displayed.
- 2 Press **FUNC3** (>>).
- 3 Press **▲▼** to select "Auto Remote", then press the **ENTER** key.
- 4 Press **▲▼** to select "ON/OFF", then press the **ENTER** key.
 - ON: When data is received in local mode, it automatically shifts to REMOTE and starts printing.
 - OFF: Remote transfer by pressing
- 5 Press the **END/POWER** key several times to end the setting.

Lighting

The interior LED lighting in this machine is installed in two places, the ceiling part and the maintenance space.

Lighting setting

- 1 Press **FUNC1** (MENU) → **▼** (twice) → **ENTER** in LOCAL.
 - MACHINE SETUP MENU will be displayed.
- 2 Press **FUNC3** (>>).
- 3 Press **▲▼** to select "Illumination", then press the **ENTER** key.
- 4 Press **▲▼** to select "Lighting Up Type", then press the **ENTER** key.
- 5 Press **▲▼** to select setting value, then press the **ENTER** key.
 - **Auto:** Automatically turns on / off in conjunction with print operation or maintenance work (cover open etc.).
 - **Manual:** Use this when you want to turn on / off arbitrarily. If you chose manual, go to step 6.
- 6 Press **▲▼** to select "Lighting Up Extention" and press the **ENTER** key.
- 7 Press **▲▼** to select the set value and press the **ENTER** key.
 - Setting value: none / 0 to 10 min
- 8 Press **▲▼** to select "Start Up Lighting" and press the **ENTER** key.

- 9 Press **▲▼** to select "ON / OFF", then press the **ENTER** key.
 - **ON:** When you want to light up when the machine is activated
 - **OFF:** When you do not want to light up when the machine is running
- 10 Press the **END/POWER** key several times to end the setting.

Turning on lighting of interior lighting

- 1 Press **SEL** key in local mode and press **FUNC1** (ADJUST).
 - Adjustment menu is displayed.
- 2 Press **▼**, select "Toggle Internal Lighting" and press **ENTER** key.
 - Each time you press the **ENTER** key, the interior lighting changes on and off.

Feeding before cut

When performing media cut (P.2-15), the print result can be cut at any place.



- Turning off the automatic feed may cut off the trailing edge of the printed result.

- 1 Press **FUNC1** (MENU) → **▼** (twice) → **ENTER** in LOCAL.
 - MACHINE SETUP MENU will be displayed.
 - 2 Press **FUNC1** (<<).
 - 3 Press **▲▼** to select "Feeding before cut", and press the **ENTER** key.
 - 4 Press **▲▼** to select "ON/OFF", then press the **ENTER** key.
 - **ON:** The feed operation is automatically performed before the cutting operation.
 - **OFF:** Media cut will be executed at the position where the **ENTER** key is pressed, without automatic feed.
-  • Excluding the case where auto cut is specified by RasterLink6 etc.
- 5 Press the **END/POWER** key several times to end the setting.

Initializing the Settings

You can return the setting of "SETUP", "MAINTENANCE" and "MACHINE SETUP" to the status before shipment.

- 1 Press **FUNC1** (MENU) → **▼** (twice) → **ENTER** in LOCAL.

• MACHINE SETUP MENU will be displayed.

- 2** Press **FUNC1** (<<).
- 3** Press **▲** **▼** to select "RESET", and press the **ENTER** key.
- 4** Press the **ENTER** key.
 - The already configured settings are initialized.
- 5** Press the **END/POWER** key several times to end the setting.

About NOZZLE CHECK MENU

Set operations concerning the nozzle missing detection function.

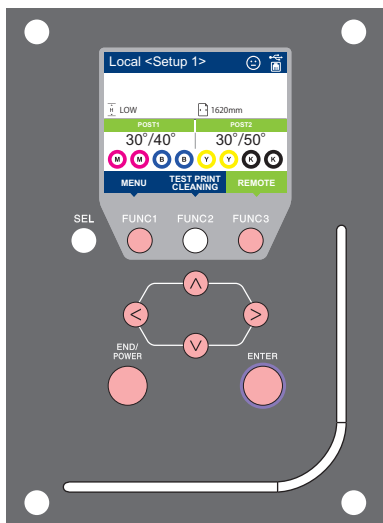

- FUNC1** : Press this to select INFORMATION MENU, or to switch to the previous screen.
- FUNC3** : Press this to switch to the next screen.
- ▲ ▼** : Use these to select a setting item.
- ENTER** : Press this to confirm a setting, etc.

◆ NOZZLE CHECK MENUs at-a-glance

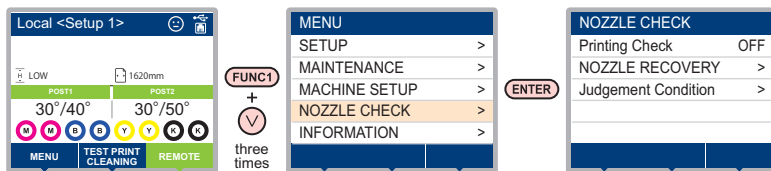

INFORMATION MENU table

Function name	Set value	Default	Meaning	
Printing Check (P.3-25)	ON/OFF	OFF	Set this when you want to conduct nozzle check at the beginning of online printing.	
(ON)	Check Interval	LENGTH	0.1 to 100.0m 30.0 m	Conducts nozzle check at each set length.*1
		FILE	1 to 100 30 file	Conducts nozzle check at each set number of files.
	Action	CLEANING	OFF/ SOFT/ NORMAL/ HARD SOFT	Sets the type of cleaning performed during recovery work.
		RETRY COUNT	0 to 3 0	Repeats the retry operation for the set number of times.
NOZZLE RECOVERY (P.3-26)	ON/OFF	OFF	Set this when you want to conduct automatic nozzle recovery.	
Judgment Condition (P.3-26)	1 to 200	1	Sets how many missing nozzles are detected for "Nozzle Missing" judgment to be made according to each color. (Maximum 16 per 1 nozzle line)*2	

*1. When the set length is reached during printing, nozzle check is conducted at the start of the next printing.

*2. Depending on the print conditions, nozzle recovery is not applied in some cases.

Printing Check Flow

Nozzle check is conducted according to the following flow at the start of printing.



- Turn the "Printing Check" setting ON to be enabled.
- Only perform RETRY COUNT and Printing Check settings when the settings are enabled.

1 nozzle check → Judgment

Detects missing nozzles.

2 Recovery operation → nozzle check → Judgment

If more missing nozzles than "Judgment Condition" are detected after the nozzle check, cleaning is performed and nozzle check is conducted again.

3 Retry → Judgment

If more missing nozzles than "Judgment Condition" are detected after the recovery operation, the recovery operation is conducted again.

- If the "RETRY COUNT" setting is configured to 1 or more, this becomes effective.

4 Printing Check → Judgment

Nozzle recovery is automatically conducted following nozzle check and recovery operation.

- Turn the "Printing Check" setting ON to be enabled.

5 Nozzle Missing judgment

If more missing nozzles than A are eventually detected, continued printing will be deemed impossible and printing will stop.

Printing Operations at "Nozzle Missing" Judgment and Error Occurrence

- **When judged to be "Nozzle Missing"** → Printing is stopped.
- **When error occurs during nozzle check** → Printing is stopped and "Printing Check" is automatically turned OFF. After recovering from the error, set "Printing Check" once again.

Setting the Printing Check

Select ON when you want to conduct nozzle check at the start of online printing.

- 1 Press **FUNC1** (MENU) \rightarrow \downarrow (3 times) \rightarrow **ENTER** in LOCAL.
 - NOZZLE CHECK MENU will be displayed.
- 2 Press the **ENTER** key.
 - "Printing Check" will be selected.
- 3 Press \uparrow \downarrow to select ON, and press the **ENTER** key.
 - The "Check Interval" setting screen will be displayed.
 - "Select OFF to not set nozzle check. Proceed to Step 11.
- 4 Press the **ENTER** key.
- 5 Press \uparrow \downarrow to select setting item, and press the **ENTER** key.
 - select the nozzle check interval from "LENGTH" or "FILE".
 - LENGTH:** nozzle check is conducted when the printed length reaches the set length. If the set distance is reached during printing, the nozzle check will be performed at the start of the next printing.
 - FILE:** nozzle check is conducted when the number of printed files reaches the set number.
- 6 Press \uparrow \downarrow to select setting value, and press the **ENTER** key.
 - The set value will differ according to the setting selected in Step 5.
 - LENGTH:** 0.1 to 100.0 m
 - FILE:** 1 to 100 files
- 7 Press the **ENTER** key twice.
 - The "Action" setting screen will be displayed.
- 8 Press the **ENTER** key.
 - "CLEANING TYPE" will be selected.
- 9 Press \uparrow \downarrow to select cleaning type, and press the **ENTER** key.
 - Setting value:** OFF/SOFT/ NORMAL/ HARD
- 10 Press \uparrow \downarrow to select retry count, and press **ENTER** .
 - Setting value:** 0 to 3
- 11 Press the **END/POWER** key several times to end the setting.

Setting the NOZZLE RECOVERY

set this if you want to conduct automatic nozzle recovery when nozzle missing is detected.

- 1 Press **FUNC1** (MENU) \rightarrow \downarrow (3 times) \rightarrow **ENTER** in LOCAL.
 - NOZZLE CHECK MENU will be displayed.
- 2 Press \downarrow , and press the **ENTER** key.
 - "NOZZLE RECOVERY" will be selected.
- 3 Press \uparrow \downarrow to select ON/OFF, and press **ENTER** .
- 4 Press the **END/POWER** key several times to end the setting.

Setting the Judgment Condition

Set the conditions for judging nozzle missing.

- 1 Press **FUNC1** (MENU) \rightarrow \downarrow (3 times) \rightarrow **ENTER** in LOCAL.
 - NOZZLE CHECK MENU will be displayed.
 - 2 Press \downarrow twice, and press the **ENTER** key.
 - "Judgment Condition" will be selected.
 - 3 Press \uparrow \downarrow to select color, and press the **ENTER** key.
 - The type of color changes depending on the ink set.
- 
- 4 Press \uparrow \downarrow to set the number of nozzles for judgment, and press the **ENTER** key.
 - 5 Press the **END/POWER** key several times to end the setting.

About INFORMATION MENU

The information of this machine can be confirmed.
The following items can be confirmed as machine information.

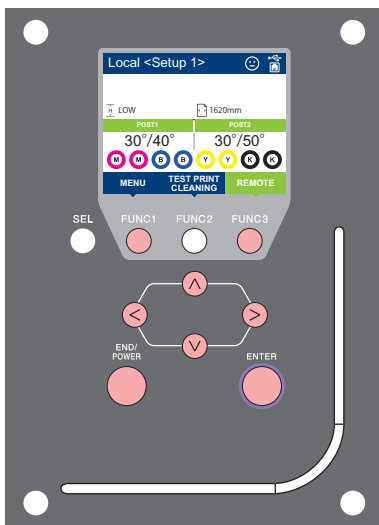

- FUNC1** : Press this to select INFORMATION MENU, or to switch to the previous screen.
- FUNC3** : Press this to switch to the next screen.
- ▲** **▼** : Use these to select a setting item.
- ENTER** : Press this to confirm a setting, etc.

◆ INFORMATION MENUs at-a-glance

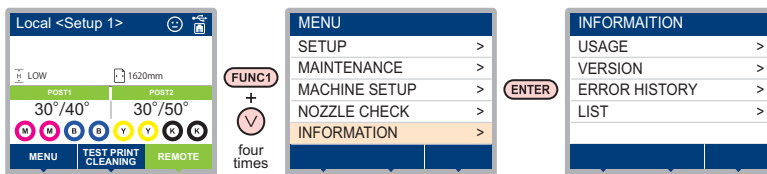

INFORMATION MENU table

Item	Description	
USAGE	WIPING	This displays how many wipings have been done.
	WASTE TANK	This displays how much waste ink has built up in the waste ink tank, as a rough percentage of the tank capacity.
	PRINT LENGTH	This displays the total length of the printing done to date.
	PRINT AREA	This displays the total area of the printing done to date.
	USE TIME	This displays the total time for which the printer has been used to date.
Spout rubber	The usage time of the spout rubber is displayed.	
VERSION	This displays the version information of this machine.	
ERROR HISTORY	This displays the history of errors and warnings to date. When you press [▲][▼], the date of occurrence (year/month/day/hour/minute) and the error/warning information are displayed alternately in the order of occurrence.	
LIST	This allows you to print the settings of this machine.	

Displaying the Information

- 1 Press **FUNC1** (MENU) \Rightarrow ∇ (4 times) \Rightarrow **ENTER** in LOCAL.
 - INFORMATION MENU will be displayed.
- 2 Press \triangle ∇ to select a information.
 - Refer to the "INFORMATION MENU", and select the information to be displayed.
- 3 Press the **ENTER** key.
 - If you selected [LIST] in step 2, the machine's settings will be printed.
- 4 Press the **END/POWER** key several times to end the setting.



- When you reset the used count of the wiper, press [FUNC2] key while [RESET?] is displayed. When you press the [ENTER] key, the number of wipings is reset.
- By pressing the function key during display of "WIPING information," "WASTE TANK information" and "Spout Rubber" in USAGE, the used counts can be reset.
 - When resetting WIPING information:**
Press [FUNC2]
 - When resetting WASTE TANK information:** Press [FUNC1]
 - To reset the spout rubber:**
Press [FUNC3]

Display maintenance status (local guidance)

- 1 Press the **ENTER** key in local mode.
 - Maintenance status is displayed.

Maintenance Condition	
Condition	☺ Good
Station/Head	Days Ago
Wash Liquid	OK
Wiper Life	OK

Maintenance Condition	
Condition	☺ Normal
Station/Head	4 Days Ago
Wash Liquid	OK
Wiper Life	OK

Maintenance Condition	
Condition	☹ Bad
Station/Head	10 Days Ago
Wash Liquid	NG
Wiper Life	NG

Chapter 4

Maintenance



This chapter

describes the items required to use this machine more comfortably, which are the methods for the daily care, the maintenance of the ink cartridges etc.







Maintenance	4-2	Set Whether to Enable NOZZLE RECOVERY	
Precautions for Maintenance	4-2	During TEST PRINT	4-15
About Cleaning Solution.....	4-2	Auto Maintenance Function	4-15
Cleaning the Exterior Surfaces	4-2	Setting the Refreshing Intervals	4-15
Cleaning the Platen	4-2	Setting the Cleaning Intervals and Type	4-16
Cleaning the Media Sensor	4-3	Replacing Consumables	4-16
Cleaning the Media Press	4-3	Replacing the Wiper	4-16
Wash the Blow down fan filter.....	4-3	Replacing the Wiper Cleaner	4-17
Maintenance of Ink Pack	4-4	Replacing the Cap	4-18
About MAINTENANCE MENU	4-5	Replacing the Cap Absorber	4-18
MAINTENANCE MENUs table	4-6	Replacing the Media Press	4-19
Maintaining the Capping Station	4-7	Replacing the Pinch roller	4-20
Cleaning the Wiper	4-7	Replacing the Spout Rubber	4-21
Cleaning the Cap	4-8	Replacing the Carriage filter	4-23
Cleaning the Cap Absorber	4-8	Male Connector Absorbent for MBIS	4-23
Nozzle cleaning	4-9	Replacing the Blow down fan filter	4-24
Cleaning the Ink Discharge Passage	4-10	Replacing the Cutter Blade	4-24
When the Machine Is Not Used for a Long Time		Media edge guide film replacement	4-25
.....	4-10	Waste ink tank management	4-26
Cleaning the Ink Head and the Area Around It		Correction of waste ink amount	4-26
.....	4-12	Change of tank capacity	4-26
Nozzle Recovery Function	4-13	If a Waste Ink Tank Confirmation Message Ap-	
Reset the Set Value	4-14	pears	4-26
Check Conditions for Which Nozzle Recovery		Replace the waste ink tank with another ...	4-26
Cannot be Performed	4-14		

Maintenance

Maintain the machine regularly or as necessary so that its accuracy will be maintained and it can continue to be used for a long time.

Precautions for Maintenance

Pay attention to the following items when maintaining this machine.

 	<ul style="list-style-type: none"> When using cleaning solution for maintenance, be sure to wear the supplied safety glasses and gloves.
	<ul style="list-style-type: none"> Never disassemble the machine. Disassembling it can result in electric shock hazards or damage to the machine. Before maintenance, be sure to turn off the power switch and unplug the power cable; otherwise, an unexpected accident may occur.
	<ul style="list-style-type: none"> Prevent moisture from entering the machine. Moisture inside the machine can cause electric shock hazards or damage to the machine.
	<ul style="list-style-type: none"> To ensure stable ink jetting, it is necessary for the machine to eject a small amount of ink (flushing) regularly when a printing (outputting) operation has not been performed for a long time. When the machine is not to be used for a long time, turn off only the power switch on the front side, leave the main power switch at the right side turned ON (in the position of), and leave the power cable connected.
	<ul style="list-style-type: none"> Do not wipe the nozzle face of the heads, wiper, caps, etc. with water or alcohol. Doing so can cause nozzle clogging or machine failure. Do not use benzene, thinner, or any chemical agent containing an abrasive. Such materials can deteriorate or deform the surface of the cover. Do not apply a lubricant, etc. to any parts inside the machine. Doing so can cause printing failure. Be careful that the cleaning solution, ink, etc. not to stick to the cover because this may cause the surface of the cover to deteriorate or deform.

About Cleaning Solution

Use the cleaning liquid dedicated for the ink being used.

Type of Ink	Applicable maintenance washings
Sublimation dye ink:Sb610	Washing liquid 03 Maintenance kit (ML003-Z-K1) [Sold separately]

Cleaning the Exterior Surfaces

When the exterior surfaces of the machine are stained, dampen a soft cloth with water or a neutral detergent diluted with water, squeeze it, and wipe the surfaces with the cloth.

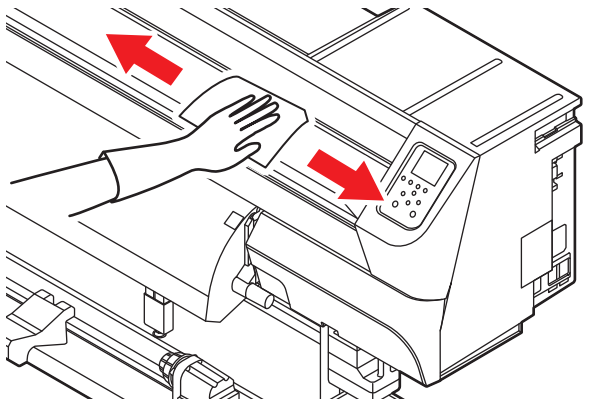





-  Prevent moisture from entering the machine. Moisture inside the machine can cause electric shock hazards or damage to the machine.

Cleaning the Platen

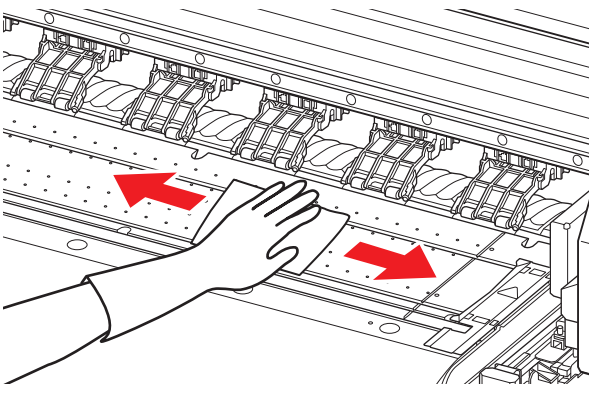
-  Turn off the main power and unplug the power cable before maintenance.

Continuing to use the dirty platen will prevent proper feeding of the media. It will also cause dried ink and attached dust to rub against the head nozzle surface and lead to print defects (e.g., nozzle clogging, deflection).



-  Prevent moisture from entering the machine. Moisture inside the machine can cause electric shock hazards or damage to the machine.
-  If the dirt is noticeable, use a soft cloth soaked in a neutral detergent diluted with water, wrung out, and then wiped off.
- Before cleaning the platen, make sure that the platen has cooled adequately.
-  The groove that slides the media press and the groove that cuts the media are particularly easy to collect dust. Please carefully remove the dust.

Cleaning the Media Sensor

Media sensors are located on the rear cover and carriage underside. When the sensor is covered with dust, etc., it may cause false detection of media.

Using a cotton swab, remove the dust, etc. accumulated on the surface of the sensor.

The backside of the machine

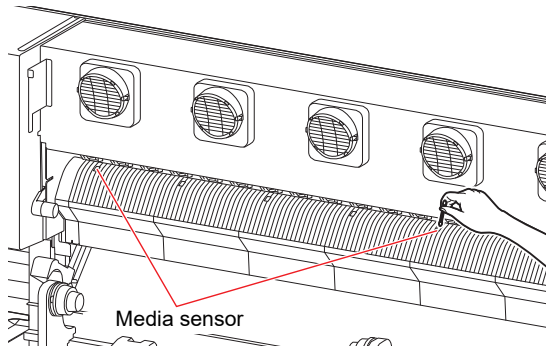

Media sensor

The lower surface of the head

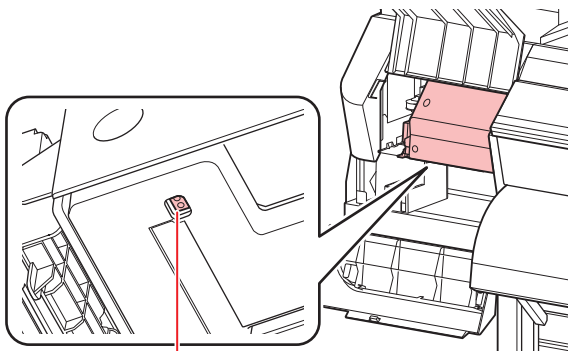

Media sensor



- Don't touch the cutter around the media sensor. Sharp cutter tip may injure you.

● Cleaning the carriage underside sensor

- 1** In LOCAL mode, select [MENU] > [Maintenance], then press the [ENTER] key.
 - The Maintenance menu is displayed.
- 2** Select [Station] > [Carriage Out] > [Move To Maint. Space], then press the [ENTER] key.
 - The carriage moves to the maintenance space.
- 3** Open the maintenance covers.
- 4** Clean the media sensor.
- 5** Close the maintenance covers, then press the [ENTER] key.

Cleaning the Media Press



- Turn off the main power and unplug the power cable before maintenance.
 - If the dirt is noticeable, use a soft cloth soaked in a neutral detergent diluted with water, wrung out, and then wiped off.
- 
- Prevent moisture from entering the machine. Moisture inside the machine can cause electric shock hazards or damage to the machine.

When the media press is covered with lint, dust, etc., a media cannot be fed normally during printing or dust sticks to the nozzles, which may result in abnormal printing.

Clean the media press regularly.

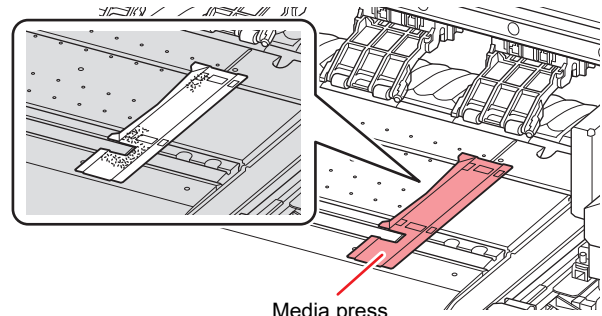

Media press



- If ink adheres to the end face of the media and becomes dirty, be sure to clean it.
- If ink adheres frequently, we recommended to set the vacuum fan to "weak" or "standard".

Wash the Blow down fan filter

If the blow down fan filter becomes dirty, or if the warning message "Wash the Blow down fan filter" appears on the display, wash (wash it with water) it.

● When to care of the filter

Every 2 weeks	If the blow down fan filter becomes dirty, wash it (wash it with water).
Every 3 months	Replace with a new blow down fan filter.

1 Remove the fan filter cover.

- Push the fan filter cover's tab outward, and pull the cover out toward you.

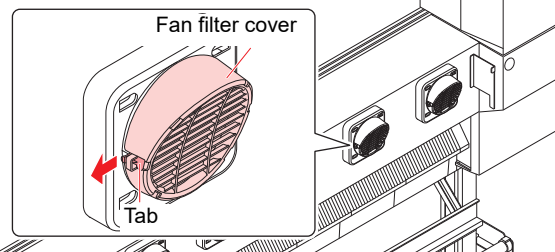

2 Remove the Blow down fan filter.

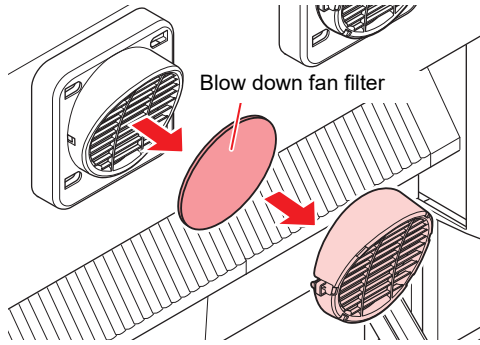

3 Wash the blow down fan filter with water.



- After washing the blow down fan filter, be sure to dry it before installing it in this machine.

4 Attach a new Blow down fan filter and return the fan filter cover.

- Fit the fan filter cover on firmly, so that it clicks into place.

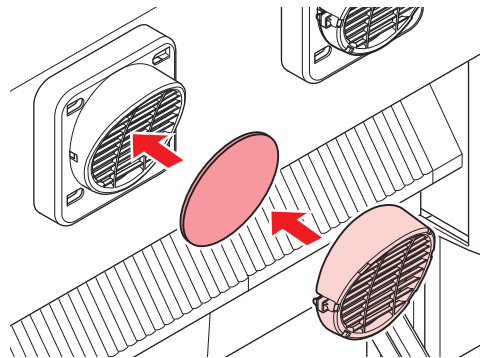

- The MBIS (optional) must be attached and removed no more than 10 times in total.



- If the cartridge is roughly tilted, this may cause an ink leak. Please tilt the cartridge gently.
- When the level of ink remaining is low, tilt the cartridge vertically, otherwise ink cannot be fully circulated.

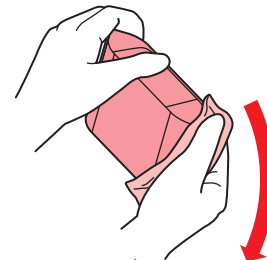

Repeat

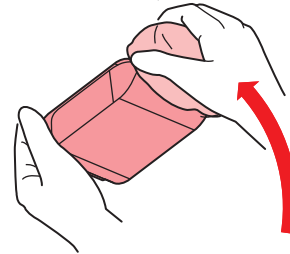

Maintenance of Ink Pack



- When using cleaning solution for maintenance, be sure to wear the supplied safety glasses and gloves.



- Shake the ink periodically. If you do not shake the ink periodically, the print quality may deteriorate rapidly.
- Please use the ink cartridges we recommended.



- If you use Water-based Sublimation Inks, shake about once a week. (A screen prompting to run once a week on the main screen is displayed.)

Shake the ink pack once a week to stir the ink inside the pack. Failure to do so will result in the ink in the pack being sedimented, and may cause color difference. (The prompt message appears on the display once a week.)

1 Shake the 2L ink pack more than 20 times slowly to the right and left.

- If the Ink pack is partially used, shake the Ink pack slowly from left to right at least 20 times, holding the ink pack lid with a paper towel.

About MAINTENANCE MENU

This provides various settings for performing maintenance.
The following items can be set in MAINTENANCE settings.

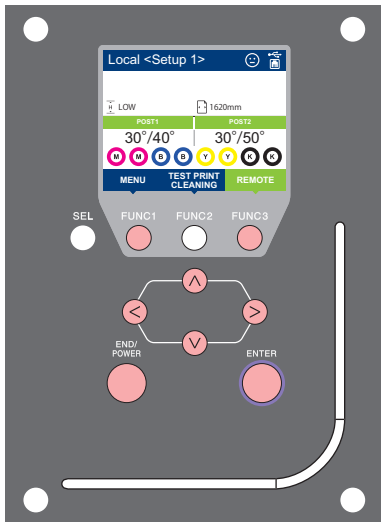

- FUNC1** : Press this to select MACHINE SETUP MENU, or to switch to the previous screen.
- FUNC2** : Press this to use the maintenance function.
- FUNC3** : Press this to switch to the next screen.
- ▲ ▼** : Use these to select a setting item.
- ENTER** : Press this to confirm a setting, etc..

◆ MAINTENANCE MENUs at-a-glance

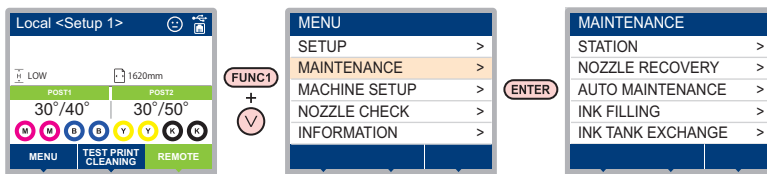

◆ Screen transition when **FUNC2** key is pressed

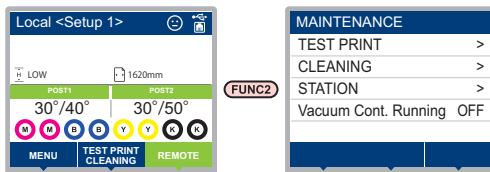

MAINTENANCE MENUS table

Item	Setting Value	Meaning	
STATION	For carrying out maintenance on the carriage and station periphery.		
	CARRIAGE OUT (☞ P.4-7)	Move To Platen Right End (☞ P.4-7)	Moves the carriage out, for carrying out cleaning of the cap periphery and wipers.
		Move to Maint Space (☞ P.4-7)	Moves the carriage out, for cleaning of head.
	NOZZLE WASH (☞ P.4-9)	1 to 99 min.	Soaks the nozzle surfaces in maintenance cleaning fluid, for carrying out recovery from nozzle clogging or bends.
	PUMP TUBE CLEANING (☞ P.4-10)		Executes washing of the suction pump tubes.
	CUSTODY WASH (☞ P.4-10)	1 to 99 min.	Carried out when the machine is going to be out of use for an extended period. Washes the nozzles and tubes beforehand, to keep the machine in optimum condition.
	REPLACE WIPER (☞ P.4-16)		Used when replacing the wiper. If the wiper is replaced, the number of times the wiper was used that is managed in this device is reset.
NOZZLE RECOVERY (☞ P.4-13)	For printing using another nozzle, if nozzle wash and so forth fail to effect recovery from nozzle clogging, etc.		
	PRINT		Prints a pattern to identify the nozzle that is clogged.
	ENTRY		Registers the faulty nozzle identified by "PRINT".
	RESET		Resets registered faulty nozzles.
	CHECK		Checks if a registered faulty nozzle can be recovered.
	TEST PRINT	ON/OFF	Selects whether or not to set the Nozzle Recovery Function during TEST PRINT.
AUTO MAINT. (☞ P.4-15)	To automatically execute the various maintenance functions. Set the execution interval for each maintenance function.		
	REFRESH		For setting the activation interval for refresh.
	CLEANING INTERVAL	The set value will differ according to the ink type being used.	For setting the activation interval for head cleaning.
	TYPE	SOFT/NORMAL/HARD	For setting the type of head cleaning.
REPLACE WasteInkTank (☞ P.4-26)	Reset Waste Ink Volume (☞ P.4-26)		Reset the waste ink tank usage count.
	Adjust Waste Ink Volume (☞ P.4-26)		Correct the error between the count value of the waste ink tank and the actual volume.
	Tank capacity (☞ P.4-26)		Set the capacity of the waste ink tank.

Maintaining the Capping Station

Maintain the ink cap, wiper, etc. located in the capping station. (STATION MAINTENANCE)



- To keep the nozzle status normal, perform wiper cleaning frequently.

The ink cap and wiper function as follows.

- Wiper:** It wipes off ink sticking to the head nozzles.
- Ink cap:** It prevents the head nozzles from clogging due to dryness.

As the machine is used repeatedly, the wiper and ink cap gradually become dirty with ink, dust, etc.

If missing nozzles cannot be corrected even after head cleaning (P.2-12) has been performed, clean using the 03 maintenance liquid kit and a clean stick.

Tools required for Maintenance

- | | |
|---|------------------|
| • Washing liquid 03 Maintenance kit (PN:ML003-Z-K1) | |
| • Cleaning Stick for Head Surrounding (PN:SPC-0527) | |
| • Gloves | • Safety glasses |



- Be sure to wear the supplied safety glasses and gloves when maintaining the capping station. Otherwise, you may get ink in your eyes.



- Do not move the carriage out of the capping station by hand. When you need to move the carriage, press the [FUNC1] key to execute the carriage-out. (P.4-7 steps 1 to 2)

Cleaning the Wiper

It is recommended that the wiper and cap be cleaned frequently in order to maintain the high image quality of the machine and keep the machine itself in good working order.



- Replace the wiper with a new one when it is extremely dirty or bent. (P.4-16)
- If a replacement message is displayed, or if cleaning does not prevent nozzle missing or deflection, replace with a new wiper.
- When cleaning the wiper, be careful that lint from the clean stick does not get left on the wiper. Remaining lint may cause image quality to deteriorate.

1

In LOCAL mode, select [MENU] > [MAINTENANCE], then press the [ENTER] key.

- The Maintenance menu is displayed.

2

Press to select [STATION MAINT.], and press the [ENTER] key.

- The carriage moves over the platen.

3

Open the front cover.

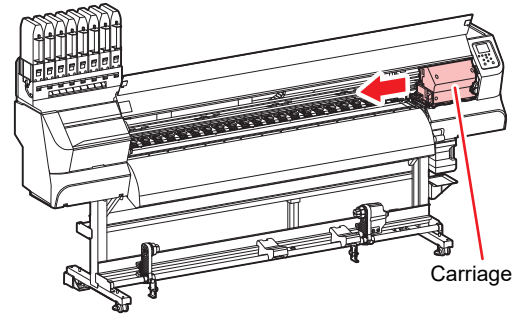

4

Remove the wiper.

- Pull out the wiper by holding the protrusions at both ends.

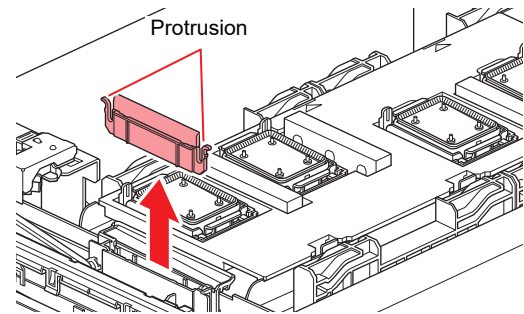

5

Clean the wiper and the bracket.

- Wipe off the ink sticking to the wiper and bracket with a clean stick dipped in cleaning solution for maintenance. Wipe off so that cleaning solution for maintenance will not remain.

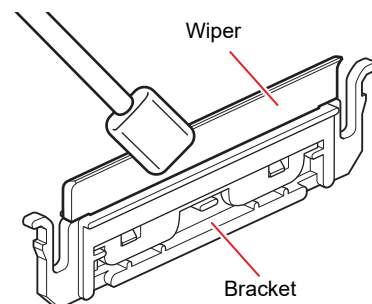

6

Set the wiper at the original position.

- Insert the wiper by holding the protrusions at both ends.



- Be sure to insert it all the way in. The wiper may come off and the machine may be damaged.

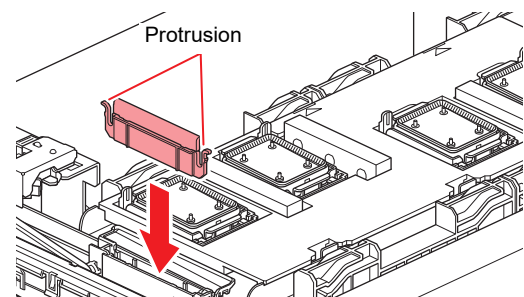

7

Press the [ENTER] key once cleaning is complete.

4

8 Close the front cover, then press the [ENTER] key.

- After its initial operation, the machine returns to step 1.

Cleaning the Cap

It is recommended that the wiper and cap be cleaned frequently in order to maintain the high image quality of the machine and keep the machine itself in good working order.



- Replace the cap with a new one when it is extremely dirty. (☞ P.4-18)
- When cleaning the wiper, be careful that lint from the clean stick does not get left on the wiper. Remaining lint may cause image quality to deteriorate.

1 In LOCAL mode, select [MENU] > [MAINTENANCE], then press the [ENTER] key.

- The Maintenance menu is displayed.

2 Select [STATION MAINT.] > [CARRIAGE OUT] > [Move To Platen Right End], then press the [ENTER] key.

- The carriage moves over the platen.

3 Open the front cover.

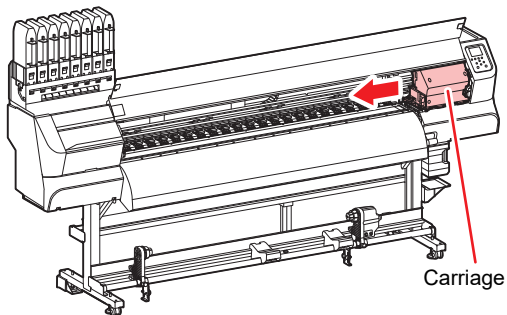

4 Clean the cap rubber.

- Wipe off the ink sticking to the cap rubber with a clean stick dipped in cleaning solution for maintenance.
- Wipe off so that cleaning solution for maintenance will not remain.

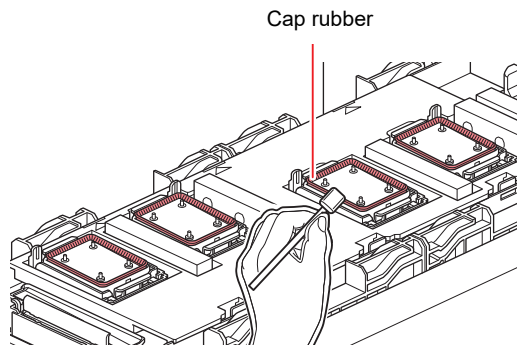

5 Press the [ENTER] key once cleaning is complete.

6 Close the front cover, then press the [ENTER] key.

- After its initial operation, the machine returns to step 1.

Cleaning the Cap Absorber

It is recommended that the wiper and cap be cleaned frequently in order to maintain the high image quality of the machine and keep the machine itself in good working order.



- If the cap absorber is dirty, replace it with a new cap absorber. (☞ P.4-18)

1 In LOCAL mode, select [MENU] > [MAINTENANCE], then press the [ENTER] key.

- The Maintenance menu is displayed.

2 Select [STATION MAINT.] > [CARRIAGE OUT] > [Move To Platen Right End], then press the [ENTER] key. press the key.

- The carriage moves over the platen.

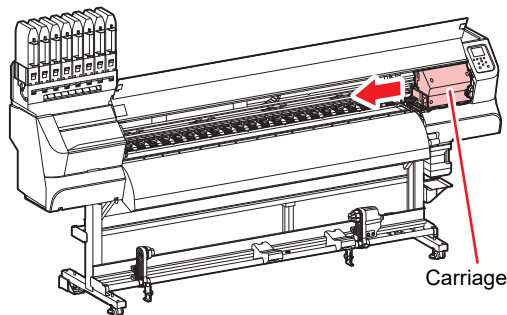

3 Open the front cover.

4 Clean the Cap Absorber.

- Use a paper towel etc. to wipe off any ink that sticks to the Cap Absorber.
- You can set the media right or center in this machine.

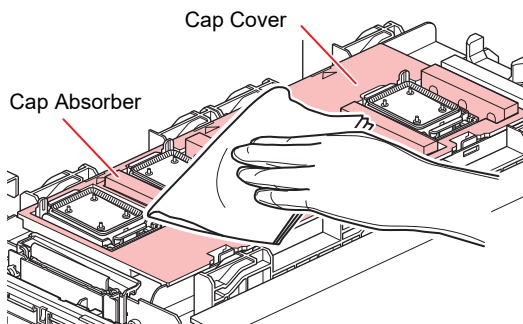

5 Press the [ENTER] key once cleaning is complete.

6 Close the front cover, then press the [ENTER] key.

- After its initial operation, the machine returns to step 1.

Nozzle cleaning

1 In **LOCAL** mode, select **[MENU] > [MAINTENANCE]**, then press the **[ENTER]** key.

- The Maintenance menu is displayed.

2 Select **[STATION MAINT.] > [NOZZLE WASH]**, select the head you want to wash, and press the **[ENTER]** key.

- The carriage moves over the platen.

3 When **"WIPER CLEANING"** is indicated on the display, open the front cover and the right maintenance cover.

4 Clean the wiper, and press the **[ENTER]** key.

- (1) Pull it out by holding the protrusions at both ends of the wiper.
- (2) Clean with a clean stick dipped in cleaning solution for maintenance.
 - Wipe off so that cleaning solution for maintenance will not remain.
- (3) Insert it in the original position by holding the protrusions at both ends of the wiper.

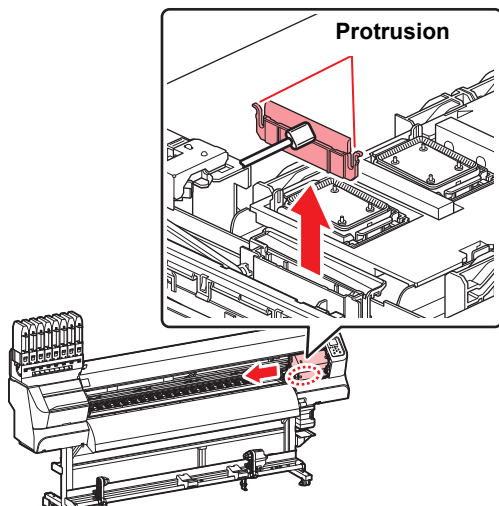

5 When you have finished cleaning the cap rubber, close the front cover and press the **[ENTER]** key.

- Wipe off the ink sticking to the cap rubber with a clean stick dipped in cleaning solution for maintenance.
- Wipe off so that cleaning solution for maintenance will not remain.
- At this time, the discharge passage is cleaned automatically.

6 Fill up the cap with cleaning solution for maintenance.

- When the cleaning liquid cartridge is enabled, the cap is automatically filled with cleaning solution.
- When the cap is full of cleaning solution, cleaning solution confirmation instructions are displayed.



- If the front cover is not closed, the cap is not automatically filled with cleaning solution. If the front cover is open, make sure you close it.



- When the cleaning liquid cartridge is not enabled, the cap is not automatically filled with cleaning solution. Open the front cover and fill the cap with the maintenance cleaning solution using a dropper. After filling up the cleaning solution, perform operations from step 7.

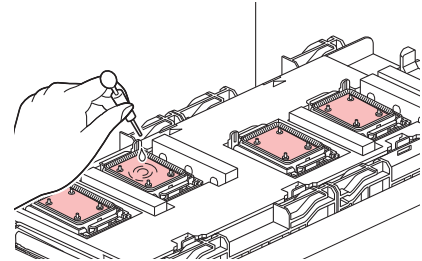

7 When a message is displayed, open the front cover and check the amount of cleaning solution in the cap.

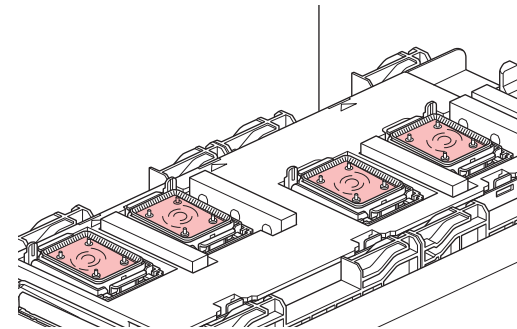

- If the cap is not full of cleaning solution, use the dropper to fill up the cap with cleaning solution until it is almost overflowing from the cap.

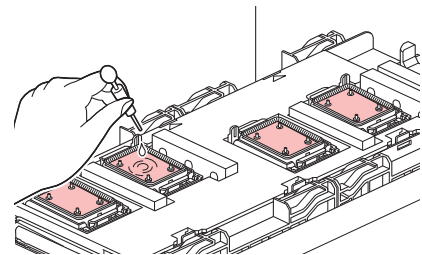

8 Close the front cover, and press **[ENTER]** key.

9 Set how long the cleaning solution should remain, and press the **[ENTER]** key.

- **Set value:** 1 to 99 min. (1 minute increments)
- The maintenance cleaning solution filled in the cap is absorbed.
- "Please Wait" is indicated on the display until the time you set has elapsed.



- When regular maintenance is required, set the leave time of cleaning solution to "60 min".



- When missing nozzles are not cleared even after performing NOZZLE RECOVERY (☞ P.4-13) or this washing several times, contact your local distributor or our sales office (to request a service call).

Cleaning the Ink Discharge Passage

In order to prevent ink clogging due to coagulation inside the ink discharge passage, clean the ink discharge passage periodically.



- Before cleaning the ink discharge path, be sure to check that the cleaning cartridge is set. If the cleaning cartridge is not set, it is necessary to fill the cleaning solution manually.

1

In LOCAL mode, select [MENU] > [MAINTENANCE], then press the [ENTER] key.

- The Maintenance menu is displayed.

2

Select [STATION MAINT.] > [DISWAY WASH], select the head you want to wash, and press the [ENTER] key.

- The carriage moves over the platen.

3

Fill up the cap with cleaning solution for maintenance.

- When the cleaning liquid cartridge is enabled, the cap is automatically filled with cleaning solution.



- If the front cover is not closed, the cap is not automatically filled with cleaning solution. If the front cover is open, make sure you close it.



- When the cleaning liquid cartridge is not enabled, the cap is not automatically filled with cleaning solution. Open the front cover and fill the cap with the maintenance cleaning solution using a dropper. After filling up the cleaning solution, perform operations from step 7.

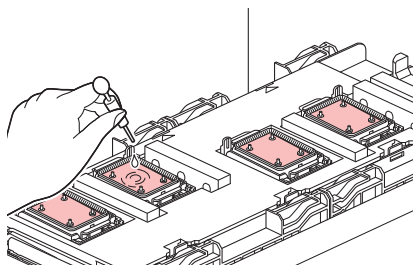

4

When an "Operations complete" message is displayed, open the front cover and check the amount of cleaning solution in the cap.

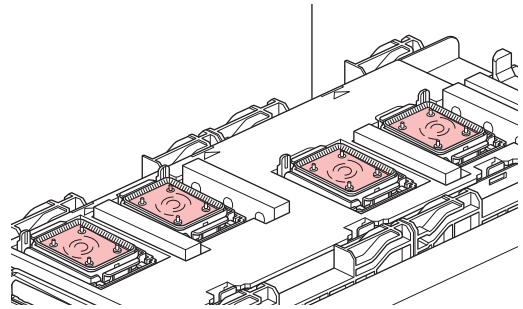

- If the cleaning solution is not full of cap, fill the cap with the maintenance cleaning solution with a dropper.

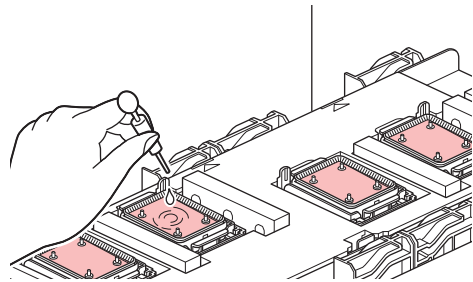

5

Close the front cover, and press the [ENTER] key.

When the Machine Is Not Used for a Long Time

When the machine is not going to be used for a week or more, use the cleaning function for storage to clean the head nozzles and ink discharge passage. Then, place the machine in storage.



- Always use the machine with the main power turned "ON". The function preventing nozzle clogging operates automatically to protect the head of the nozzle.
- The head nozzle may result in nozzle clogging if the main power switch is left OFF for a long time.

Check the items on the right beforehand.

Is [NEAR END] or [INK END] displayed?

- The cleaning solution or ink is absorbed when the nozzles are washed. At this time, if the state of "INK END" or "NEAR END" is detected, the nozzle washing operation cannot start.
- In case of INK END etc., replace with a new bottle.



- When the warning message "Check waste ink" is indicated, check the waste ink tank and perform operations by referring to P.4-26 "If a Waste Ink Tank Confirmation Message Appears" according to the situation.

1 In LOCAL mode, select [MENU] > [MAINTENANCE], then press the [ENTER] key.

- The Maintenance menu is displayed.

2 Select [STATION MAINT.] > [CUSTODY WASH], then press the [ENTER] key.

- The carriage moves over the platen.

3 When "WIPER CLEANING" is indicated on the display, open the front cover.

4 Clean the wiper.

- (1) Open the front cover, and then pull it out by holding the protrusions at both ends of the wiper.
- (2) Clean with a clean stick dipped in cleaning solution for maintenance. Wipe off so that cleaning solution for maintenance will not remain.
- (3) Insert it in the original position by holding the protrusions at both ends of the wiper.

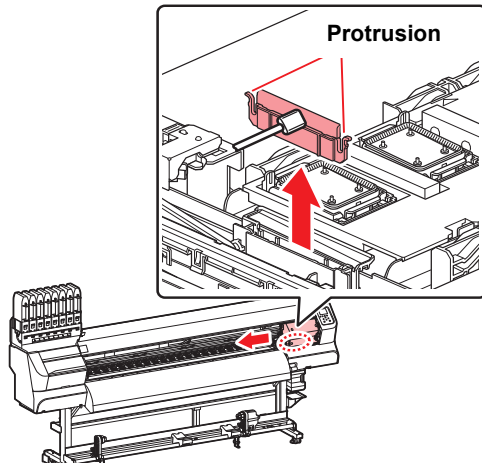

5 Press the [ENTER] key.



- Until wiper cleaning is completed, [COMPLETED (NEXT): ENT] is displayed on the screen. After completing operations up to step 5, press the [ENTER] key. If you press the [ENTER] key before cleaning is completed, the machine moves to the next washing procedure.

6 Clean the cap rubber.

- Wipe off the ink sticking to the cap rubber with a clean stick dipped in cleaning solution for maintenance.
- Wipe off so that cleaning solution for maintenance will not remain.
- At this time, the discharge passage is cleaned automatically.

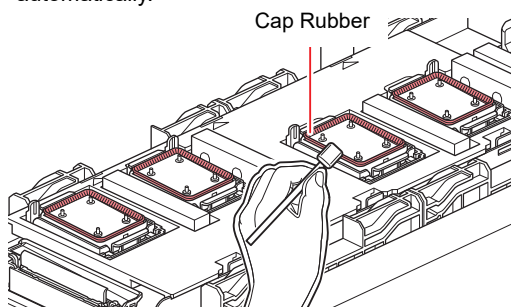

7 Close the front cover, and press the [ENTER] key.

- When the cleaning liquid cartridge is enabled, the cap is automatically filled with cleaning solution.
- When the cap is full of cleaning solution, cleaning solution confirmation instructions are displayed.



- If the front cover is not closed, the cap is not automatically filled with cleaning solution. If the front cover is open, make sure you close it.
- When the cleaning liquid cartridge is not enabled, the cap is not automatically filled with cleaning solution. Open the front cover and fill the cap with the maintenance cleaning solution using a dropper. After filling up the cleaning solution, perform operations from step 11.

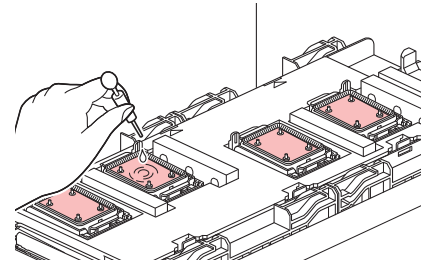

8 When a message is displayed, open the front cover and check the amount of cleaning solution in the cap.

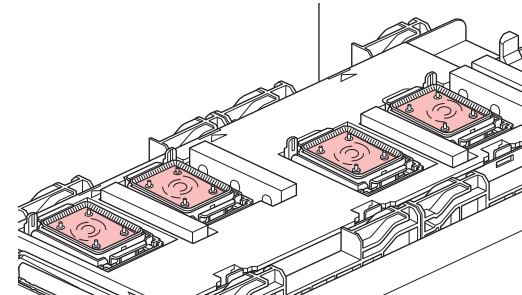

- If the cleaning solution is not full of cap, fill the cap with the maintenance cleaning solution with a dropper.

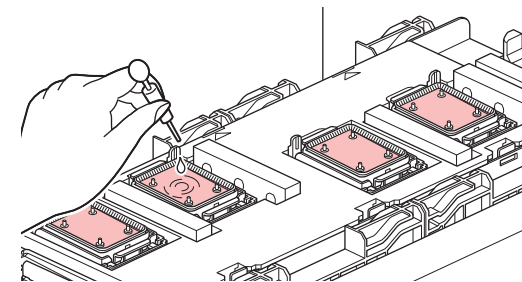

9 Close the front cover, and press the [ENTER] key.

10 Set how long the cleaning solution should remain.

- Set value: 1 to 99 min. (1 minute increments)

11 Press the [ENTER] key.

- The nozzles are washed.
- When the nozzles have been completely washed, the head moves to the maintenance position.

12 Fill up the cap with cleaning solution for maintenance.

- When the cleaning liquid cartridge is enabled, the cap is automatically filled with cleaning solution.



- If the front cover is not closed, the cap is not automatically filled with cleaning solution. If the front cover is open, make sure you close it.



- When the cleaning liquid cartridge is not enabled, the cap is not automatically filled with cleaning solution.

Open the front cover and use the dropper to fill up the cap with cleaning solution until it is almost overflowing from the cap.

After filling up the cleaning solution, perform operations from step 16.

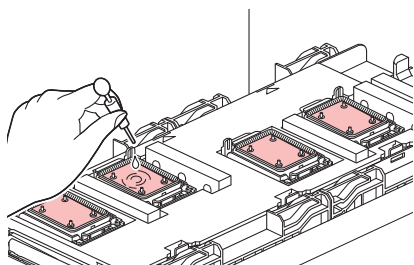

13 When an "Operations complete" message is displayed, open the front cover and check the amount of cleaning solution in the cap.

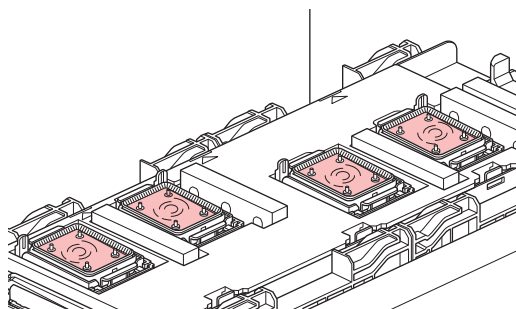

- If the cleaning solution is not full of cap, fill the cap with the maintenance cleaning solution with a dropper.

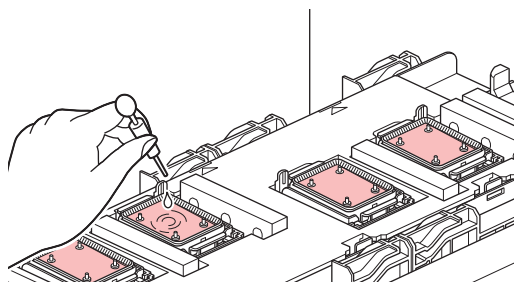

14 Close the front cover, and press the [ENTER] key.

- After its initial operation, the machine returns to the display in step 2.

Cleaning the Ink Head and the Area Around It

Because the ink head employs a very precise mechanism, due care needs to be taken when it is cleaned.

Using a clean stick, etc., rub off gelatinous ink or dust that may stick to the lower part of the slider and the area around the ink head. In doing so, never rub the nozzles of the head.

Tools required for cleaning

- | | |
|---|----------|
| • Cleaning Stick for Head Surrounding (PN:SPC-0527) | |
| • Safety glasses | • Gloves |



- Be sure to wear the supplied safety glasses and gloves when cleaning the area around the ink head. Otherwise, you may get ink in your eyes.
- The ink contains organic solvents. If you get ink on your skin or in your eyes, rinse thoroughly with a lot of clean water.

1 In LOCAL mode, select [MENU] > [MAINTENANCE], then press the [ENTER] key.

- The Maintenance menu is displayed.

2 Select [STATION MAINT. > ["CARRIAGE OUT] > [Move To Maint.Space], then press the [ENTER] key.

- The carriage moves over the platen.

3 Open the maintenance cover.

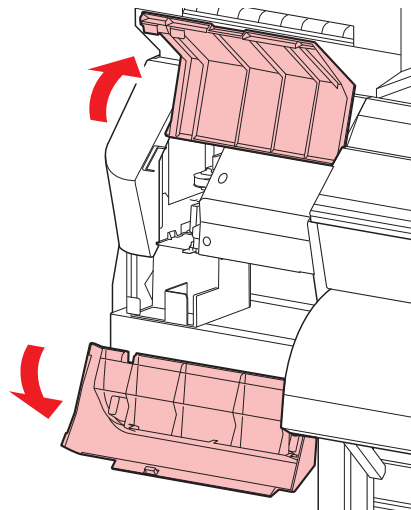

4 Use a clean stick to wipe ink off the head surface.

- Never rub the nozzles.

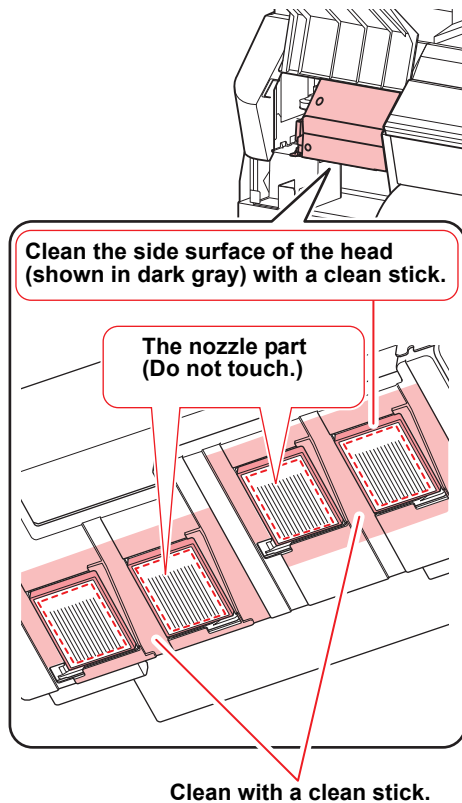

5 Press the [ENTER] key after cleaning.

6 Close the maintenance cover, and press the [ENTER] key.

- After its initial operation, the machine returns to LOCAL.

Nozzle Recovery Function

When missing nozzles cannot be improved at specific points, other good nozzles can be used as alternatives for printing.

1 Check the nozzle status with the test print.

- Test Printing (P.2-10)
- Correspondence of head / nozzle row is as follows. There are eight rows of nozzles in one head, indicated by A to H.



2 In LOCAL mode, select [MENU] > [MAINTENANCE], then press the [ENTER] key.

- The Maintenance menu is displayed.

3 Select [NOZZLE RECOVERY] > [PRINT], then press the [ENTER] key.

4 Select the HEAD to want to print, press to select "PRINT START", and press the [ENTER] key.

- All patterns from nozzle row A to H in the selected head are printed.

5 Specify the position of nozzle missing.

- Locate the missing nozzle with the right scale and the upper scale.
- If you select "Register", without going to print, go to the nozzle row selection procedure (step 9).

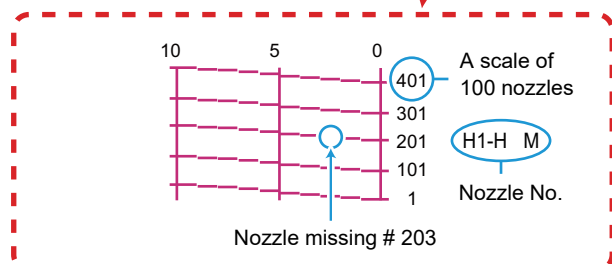
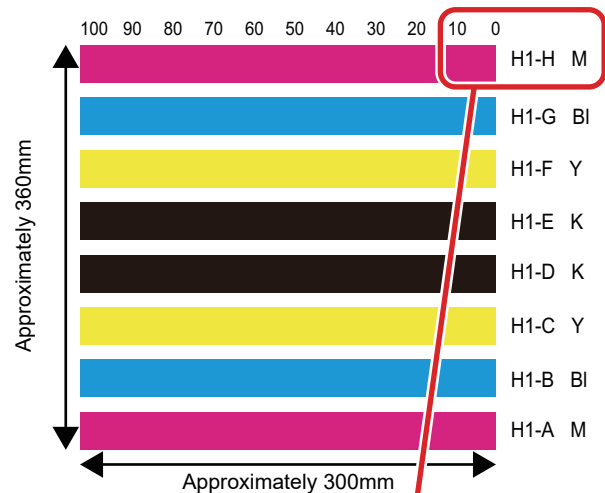

- 6** Select the Nozzle line that needs **NOZZLE RECOVERY**, and then press the **[ENTER]** key.

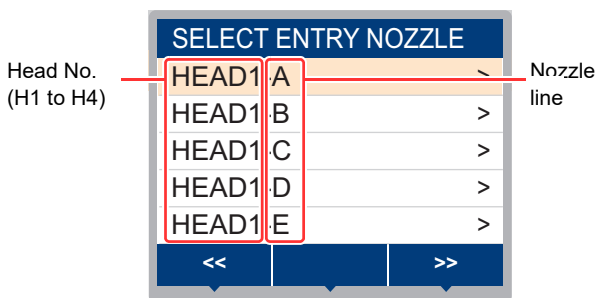

- 7** Register the Nozzle number that needs **NOZZLE RECOVERY**, and press the **[ENTER]** key.

- (1) Press **[▲][▼]** to select the registration number from 1 to 10, and press the **[ENTER]** key.
- (2) Press **[▲][▼]** to register the nozzle number that needs recovery, and press the **[ENTER]** key.

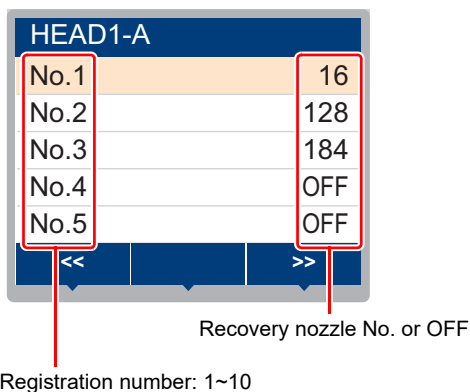

- 8** Press **[END/POWER]** several times to end the setting.



- Up to 10 nozzles can be registered per 1 nozzle line.
- Even if you use this function, time required for drawing does not change.
- Nozzle recovery is not applied when printing using the lowest number of passes.

Reset the Set Value

- 1** In **LOCAL** mode, select **[MENU] > [MAINTENANCE]**, then press the **[ENTER]** key.
 - The Maintenance menu is displayed.
- 2** Select **[NOZZLE RECOVERY] > [RESET]**, then press the **[ENTER]** key.
- 3** Select the **HEAD** to want to print, then press the **[ENTER]** key.
 - A reset confirmation message will be displayed.

- 4** Press the **[ENTER]** key.

- 5** Press the **[END/POWER]** several times to end the setting.

Check Conditions for Which Nozzle Recovery Cannot be Performed

- 1** In **LOCAL** mode, select **[MENU] > [MAINTENANCE]**, then press the **[ENTER]** key.
 - The Maintenance menu is displayed.
- 2** Select **[NOZZLE RECOVERY] > [CHECK]**, then press the **[ENTER]** key.
 - Judgment Condition input screen will be displayed.

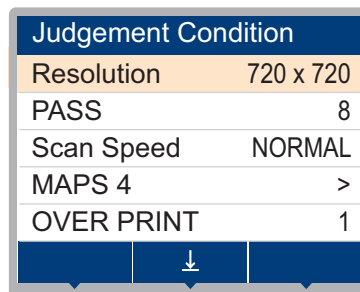

- 3** Adapt each item of the judgment conditions to your current state.

- (1) Press **[▲][▼]** to select the setting item, and press the **[ENTER]** key.
- (2) Press **[▲][▼]** to select the setting value, and press the **[ENTER]** key.
- (3) Repeat steps (1) and (2) to set all of the items.

- 4** Press the **[FUNC2]** key.

- Begin to check if nozzle recovery at the set printing conditions can be done.
- When the check is complete, the judgment result is displayed on the screen.

If nozzle recovery possible

Judgement result	
Judgement result	OK

If nozzle recovery is not possible

Judgement result	
Judgement result	NG
HEAD1-A	1
HEAD1-B	0
HEAD1-C	0
HEAD1-D	2
Judgement result	
HEAD1-E	1
HEAD1-F	0
HEAD1-G	0
HEAD1-H	0
HEAD2-A	0

Head no. and nozzle line The number of nozzles that cannot be recovered.

5 Press the [END/POWER] several times to the setting.

Set Whether to Enable NOZZLE RECOVERY During TEST PRINT

By setting the following to "ON" and registering the nozzle numbers you want to recover using P.4-13 "Nozzle Recovery Function", the Nozzle Recovery Function is enabled when performing test printing (P.2-11).

- In LOCAL mode, select [MENU] > [MAINTENANCE], then press the [ENTER] key.
 - The Maintenance menu is displayed.
- Select [NOZZLE RECOVERY] > [TEST PRINT], then press the [ENTER] key.
- Select ON/OFF, and press the [ENTER] key.
- Press the [END/POWER] several times to end the setting.

Auto Maintenance Function

To get the best out of this machine, you can set various maintenance operations to be performed automatically. This section explains how to set the times at which the automatic maintenance operations are performed. You can prevent problems such as ink clogging by performing automatic maintenance periodically. (Auto maintenance function)

For the auto maintenance functions, the following items can be set:



- When you perform maintenance manually, after manual maintenance is complete and when the time set for the automatic maintenance function has passed, maintenance starts automatically.

Function name	Descriptions
REFRESH	Sets the interval between each refreshing operation.
CLEANING INTERVAL	Sets the interval between each cleaning operation.
TYPE	Sets the cleaning type.



- If the "Replace Waste Ink Tank" warning message is displayed, the operation set in the auto maintenance function is not carried out. Perform the operations in P.4-26 if required.
- When the power switch on the front of the machine is turned off, check the waste ink tank.

Setting the Refreshing Intervals

Sets the interval between each operation to eject a small amount of ink from the nozzles to prevent nozzle clogging.

- In LOCAL mode, select [MENU] > [MAINTENANCE], then press the [ENTER] key.
 - The Maintenance menu is displayed.
- Select [AUTO MAINT.] > [REFRESH], then press the [ENTER] key.
- Set the refreshing interval, and press the [ENTER] key.
 - Set value:** The set value differs according to the ink type being used.
- Press the [END/POWER] several times to end the setting.

Setting the Cleaning Intervals and Type

The cleaning type and the interval between each cleaning operation are set.

1 In **LOCAL** mode, select **[MENU] > [MAINTENANCE]**, then press the **[ENTER]** key.

- The Maintenance menu is displayed.

2 Select **[CLEANING INTERVAL]** or **[TYPE]**, then press the **[ENTER]** key.

3 Select the setting value, and press the **[ENTER]** key.

- **Set value:**
The set value differs according to the ink type being used.
- **Set value of type:**
NORMAL/ HARD

4 Press the **[END/POWER]** several times to end the setting.

Replacing Consumables

Use the supply items to replace parts if they are excessively dirty, damaged, or deformed.

To order replacement consumable items, contact your local dealer or our service office.

For more information on other consumable items, refer to our website. <https://mimaki.com/supply/inkjet.html>

Replacing the Wiper

When the display indicates the warning message "REPLACE WIPER", it is necessary to replace the wiper with a new one as soon as possible.

The wiper used depends on the height of the head.

Range	Wiper
Low	Wiper (PN:SPC-0843)
Mid	
Hi	HiGap wiper (PN:SPC-0850)



SPC-0843

SPC-0850



- Be sure to use a wiper that matches the height of the head. It may cause discharge failure such as nozzle clogging or color mixing.
- If you change the wiper, the number of times the wiper is used is reset.



- If nozzle missing or deflection does not occur after cleaning, it can be used as is. But be sure to replace it if scratches and fluff on the wiper tip.
- The wiper is an optional item. You can buy one through your local dealer or from our service office.

1 In **LOCAL** mode, select **[MENU] > [MAINTENANCE]**, then press the **[ENTER]** key.

- The Maintenance menu is displayed.

2 Select **[STATION MAINT.] > [REPLACE WIPER] > [Move To Platen Right End]**, then press the **[ENTER]** key.

- The carriage moves over the platen.

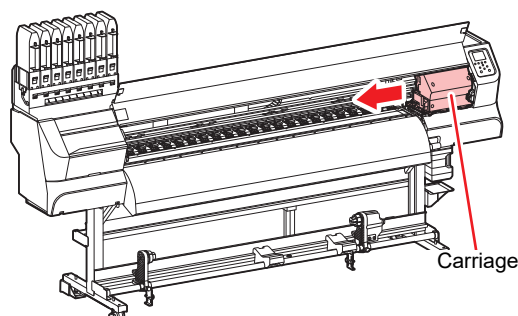

Carriage

3 Remove the wiper.

- Pull out the wiper by holding the protrusions at both ends.

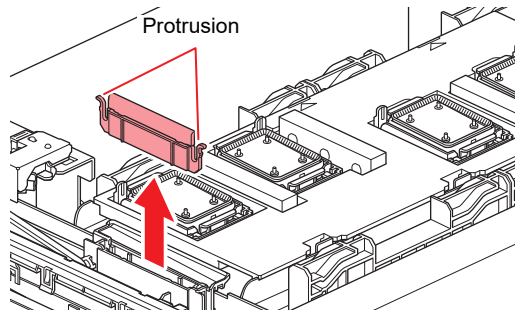

4 Insert a new wiper.

- Hold the protrusions at both ends of the wiper and insert it firmly all the way in.

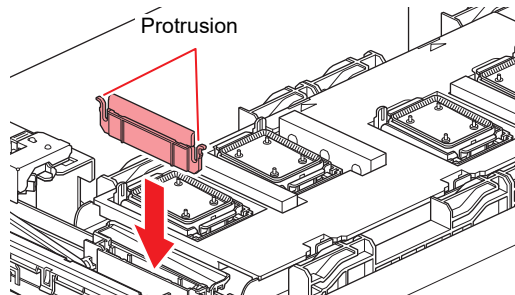

5 Close the front cover, and press the [ENTER] key.

- After its initial operation, the machine returns to LOCAL.

Replacing the Wiper Cleaner

Wiper cleaner (PN:SPA-0243) is a consumable item. Exchange about once a year.



- The wiper cleaner is an optional item. You can buy one through your local dealer or from our service office.

1 In LOCAL mode, select [MENU] > [MAINTENANCE], then press the [ENTER] key.

- The Maintenance menu is displayed.

2 Select [STATION MAINT.] > [CARRIAGE OUT] > [Move To Platen Right End], then press the [ENTER] key.

- The carriage moves over the platen.

3 Open the front cover.

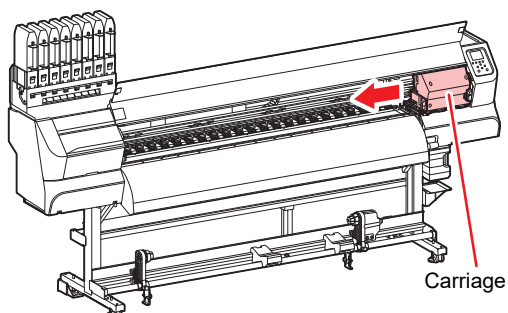

4 Remove the fitting.

- Pull out the fitting by holding the protrusions at both ends.

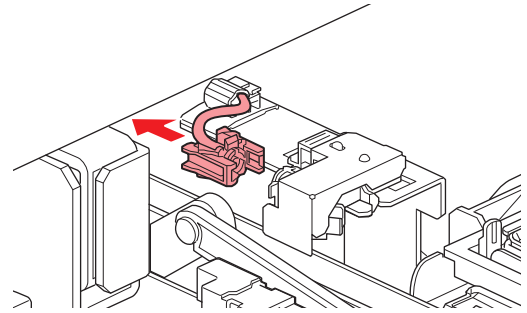

5 Remove the wiper cleaner.

- Pull it to the front to remove it.

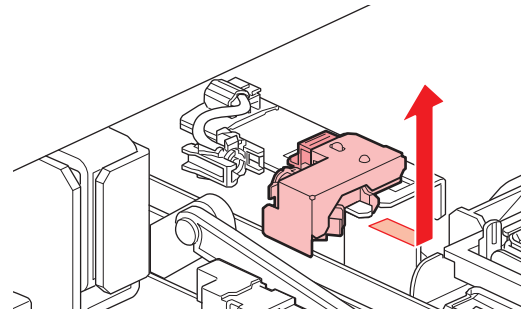

6 Insert a new wiper cleaner.

- Slide it all the way in to install it.

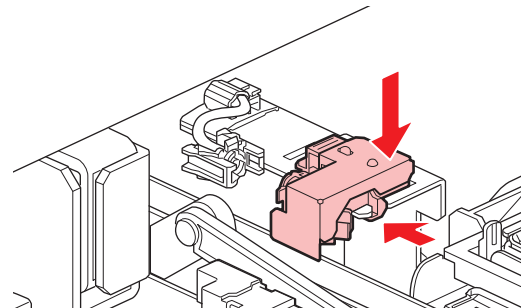

7 Attach the fitting.

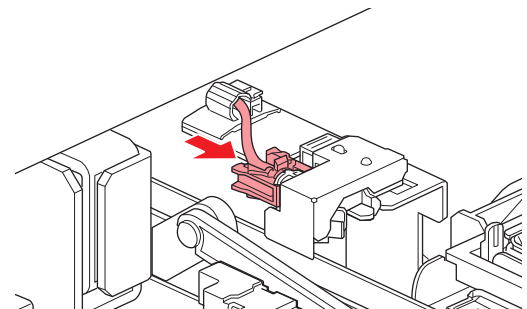

8 When replacement is complete, press the [ENTER] key.

9 Close the front cover, and press the [ENTER] key.

- After its initial operation, the machine returns to step 1.

Replacing the Cap

The cap (PN:SPC-0842) is a consumable item. If the cap becomes dirty or gets scratches, or nozzle drop outs do not change even after cleaning (suction failure), replace with the new cap.



- Be sure to replace the cap edge if it is scratched or damaged as shown below.

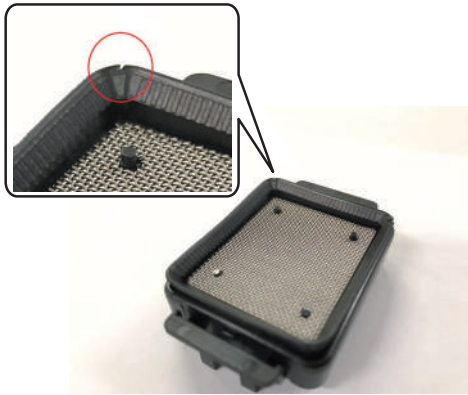

- The Cap is an optional item. You can buy one through your local dealer or from our service office.

1 In LOCAL mode, select [MENU] > [MAINTENANCE], then press the [ENTER] key.

- The Maintenance menu is displayed.

2 Select [STATION MAINT.] > [CARRIAGE OUT] > [Move To Platen Right End], then press the [ENTER] key.

- The carriage moves over the platen.

3 Open the front cover.

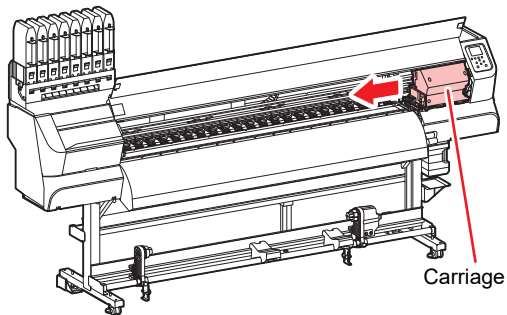

4 Remove the Cap.

- Pull it up while pushing in the protrusion of the cap.

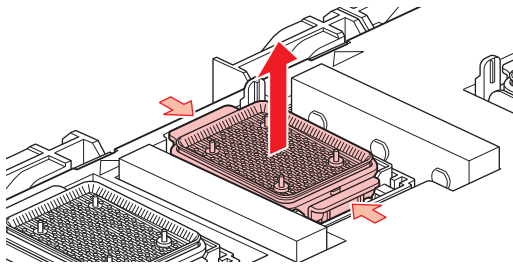

5 Apply washing liquid to the hole.

- Apply washing liquid 1-2 drops to the front hole using a dropper.

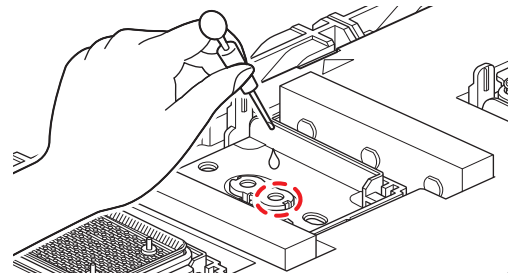

6 Attach a new Cap

- Place the notch this side and securely fit until it clicks.

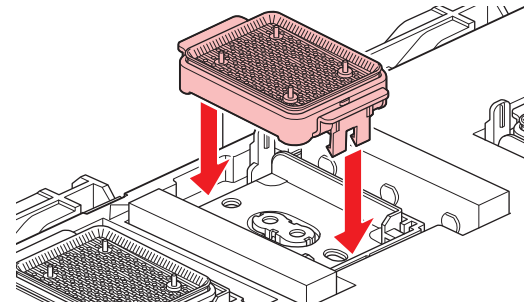

7 When replacement is complete, press the [ENTER] key.

8 Close the front cover, and press the [ENTER] key.

- After its initial operation, the machine returns to step 1.

Replacing the Cap Absorber

Cap Absorber (PN:SPC-0845) is a consumable item. If the dirt is severe or the ink falls off from the carriage, replace it.



- The Cap Absorber is an optional item. You can buy one through your local dealer or from our service office.

1 In LOCAL mode, select [MENU] > [MAINTENANCE], then press the [ENTER] key.

- The Maintenance menu is displayed.

2 Select [STATION MAINT.] > [CARRIAGE OUT] > [Move To Platen Right End], then press the [ENTER] key.

- The carriage moves over the platen.

3 Open the front cover.

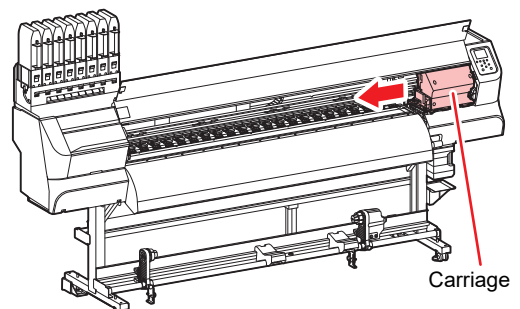

4 Remove the Cap Absorber.

- Remove the clasps at the front (3 points) and pull it out.

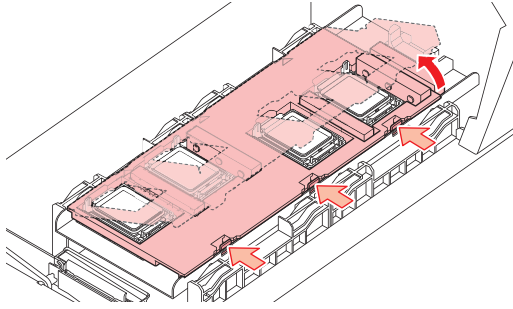
**5 Insert a new Cap Absorber.**

- Align the notches with the protrusions at the back and install it.

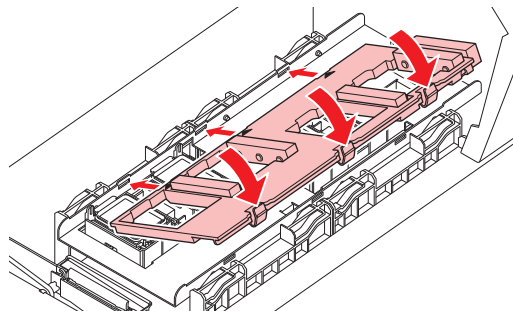
**6 When replacement is complete, press the [ENTER] key.****7 Close the front cover, and press the [ENTER] key.**

- After its initial operation, the machine returns to step 1.

Replacing the Media Press

Wiper cleaner (PN:SPA-0243) is a consumable item. Exchange about once a year.

If the media press (PN:SPC-0789) becomes deformed and rubs against the head, you need to replace it.



- The media press is an optional item. You can buy one through your local dealer or from our service office.
- Make sure you do not lose the slider when you remove it from the media press.

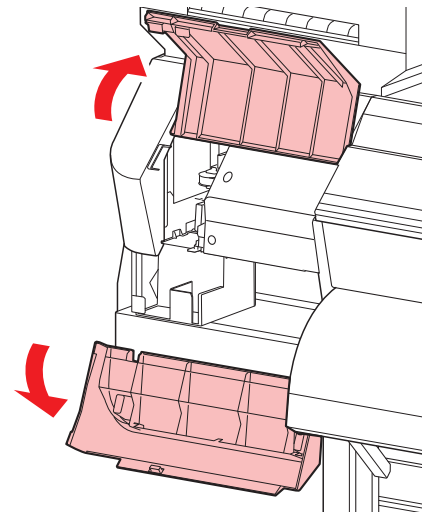

- When turning the main power switch off for moving the machine or for solving the error or the like, press the [END/POWER] key a long time on the front of the machine, check the display is turned off on the operation panel, and then turn the main power switch off.
- Turn off the main power and unplug the power cable before replacing the media holder.

1 Open the maintenance cover.**2 Remove the media press stopper.**

- Loosen the side screw and remove it.

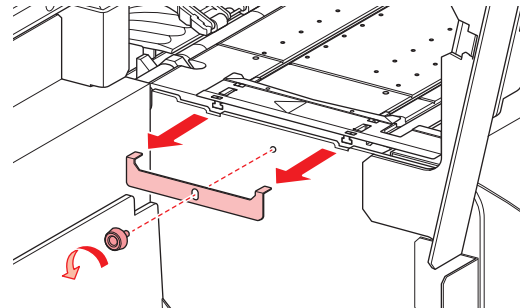
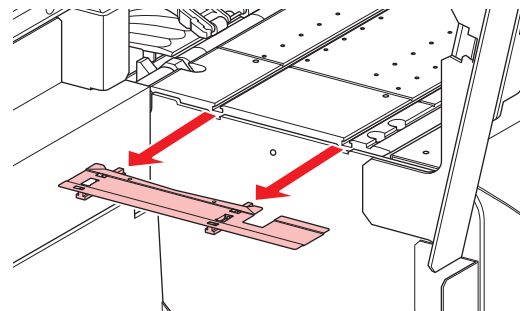
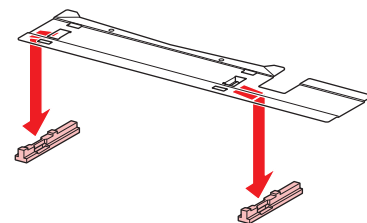
**3 Remove the media press.****4 Remove the slider.****5 Attach the slider to the new media press.**

- Hook the hole of the slider on the protrusion of the media press.

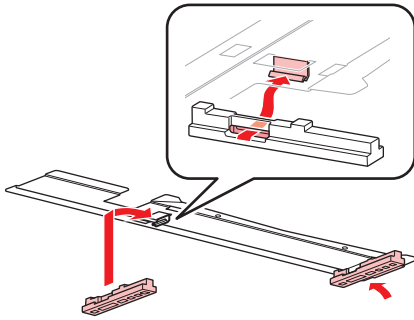

6 Attach the media press.

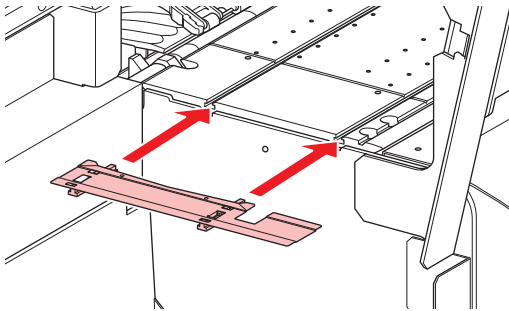

7 Attach the media press stopper.

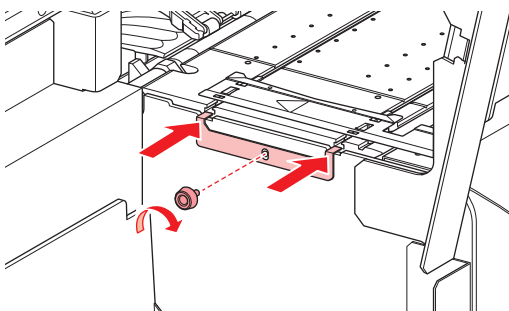

8 Close the maintenance cover.

- 9** Turn the main power switch ON.
- (1) Set the main power switch located on the side of this machine to the "I" side.
 - When the power is turned on, the firmware version is displayed and the initial operation is executed.
 - (2) Press the [END / POWER] key to turn on the power.

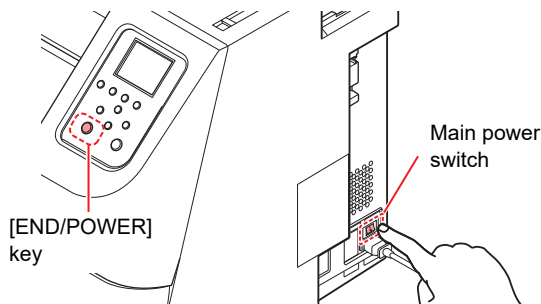

Replacing the Pinch roller

When you notice that the pinch roller (PN:SPA-0247) is worn out or dirty, or when the warning message "Check the pinch roller for dirt" appears on the display, please check and replace the pinch roller immediately.

● When to replace of the pinch roller

For 12 hours a day	Replace every month
For 24 hours a day	Exchange every 2 weeks



- The pinch roller is an optional item. You can buy one through your local dealer or from our service office.
- Since the parts are small, you need to take extra care not to drop them into the gaps in the machine.



- When turning the main power switch off for moving the machine or for solving the error or the like, press the [END/POWER] key a long time on the front of the machine, check the display is turned off on the operation panel, and then turn the main power switch off.
- Turn off the main power and unplug the power cable before replacing the media holder.

1 Open the front cover.

2 Raise the clamp lever to keep the pinch roller lifted.

3 Remove the O-ring retaining the pinch roller.

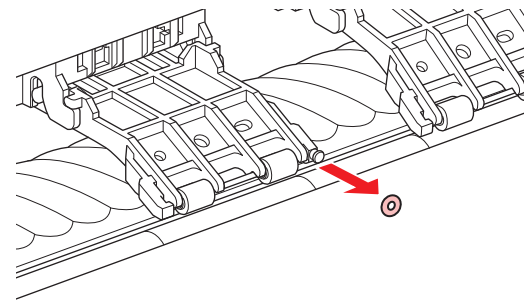

4 Remove the pinch roller.

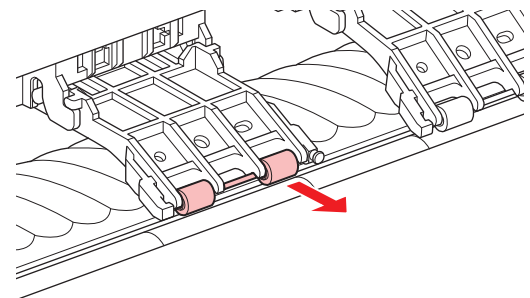

5 Insert a new pinch roller.

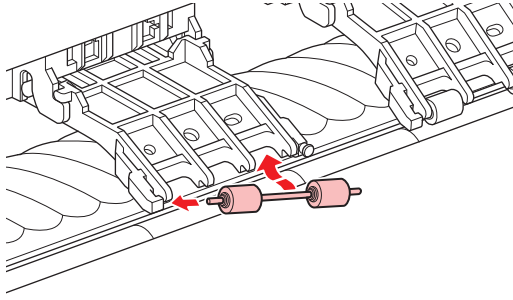

6 Insert the O-ring.

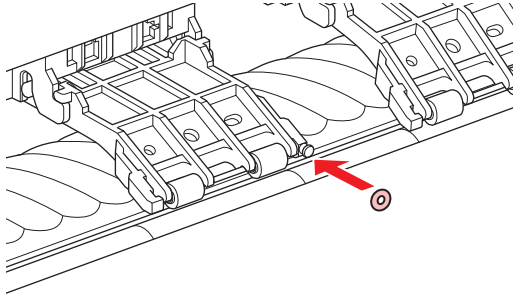

7 Close the front cover.

8 Turn the main power switch ON.

- (1) Set the main power switch located on the side of this machine to the "I" side.
 - When the power is turned on, the firmware version is displayed and the initial operation is executed.
- (2) Press the [END / POWER] key to turn on the power.

Replacing the Spout Rubber

Install the spout rubber in an eco case in order to reduce ink leakage from the 2L ink pack.

The spout rubber is a supplied part. (SPA-0317: Set of 8 Rubber stopper 2L for case)

The replacing timing sign of the spout rubber will be shown about once every half-year. Please replace the spout rubber when you see the sign on the display.



- When exchanging 2L ink pack, be sure to wear the included safety glasses and gloves. Ink may spatter and get in your eyes accidentally.



- Replace all eight spout rubber. as a set at the same time.
- Depending on the usage environment and usage conditions, the spout rubber may deteriorate within half a year. If the gap in the center expands as shown in the picture, please replace it regardless of if there is a warning message.



The beginning of spout rubber



It is available to use



It is necessary to replace



- Reset the counter according to the following procedures if replacing any time other than when the warning is displayed.
- (1) Press "MENU" in LOCAL to select "INFORMATION" and press the "ENTER" key.
 - (2) Select "USAGE" and press the "ENTER" key.
 - (3) Press the "FUNC3" key.
 - (4) If the following appears, press the "ENTER" key to reset the counter.

EcoCase/SpoutRubber
RESET? [ENT]

1 Open the 2L eco case.

2 Remove the 2L ink pack.

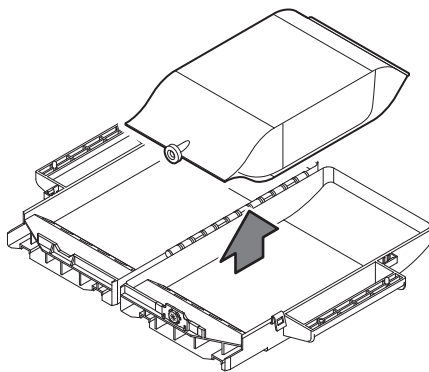

3 Remove the spout rubber.

- Press against the top of the spout rubber and pull it out vertically.

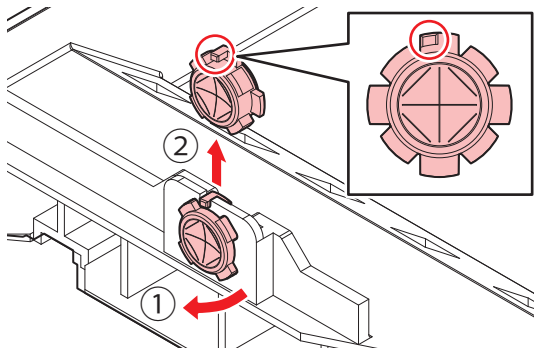

4 Attach the new spout rubber from outside of the eco-case.

- Insert it aligning the positioning protrusion of the spout rubber to the concave position of the eco-case.
- Be careful of the direction of the rubber when installing.
- Push the entire rubber into groove until the spout rubber fits evenly.



- Bending the entire spout rubber makes it easier to insert from the outside of the case.

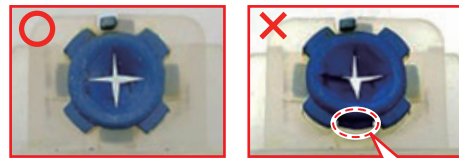
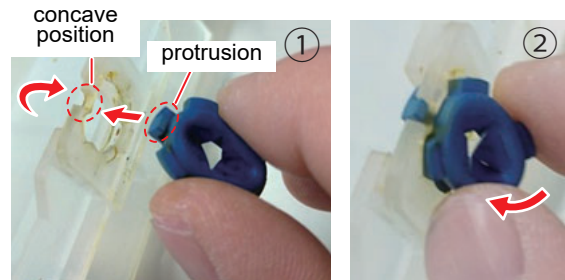

The ribs don't fit. If it is not seated in the groove correctly, the spout rubber will be damaged.

5 Moisten the surface of the spout rubber with maintenance solution sufficiently before inserting.

- Inserting the rubber into the eco-case without moistening may damage the rubber.
- In that case, use a maintenance solution that is suitable for the ink type.

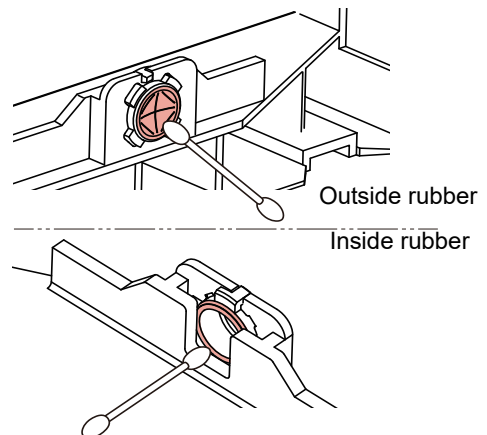

Replacing the Carriage filter

Replace the Carriage filter (PN:SPC-0844) when it gets too dirty.



- The Carriage filter is an optional item. You can buy one through your local dealer or from our service office.



- When turning the main power switch off for moving the machine or for solving the error or the like, press the [END/POWER] key a long time on the front of the machine, check the display is turned off on the operation panel, and then turn the main power switch off.
- Turn off the main power and unplug the power cable before replacing the media holder.

1 Open the front cover.

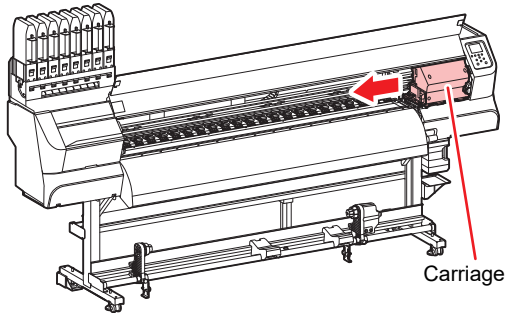

2 Remove the Carriage filter.

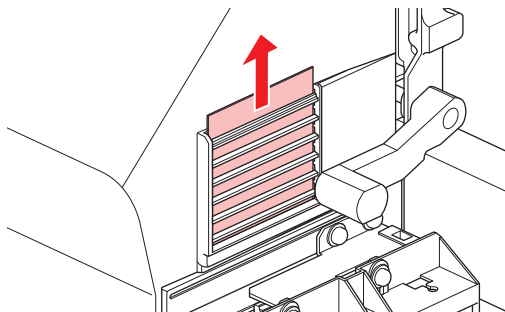

3 Insert a new Carriage filter.

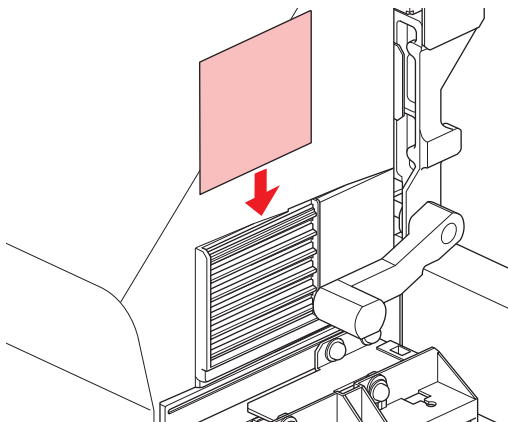

- Pay attention to the direction to install the Carriage filter.

OK

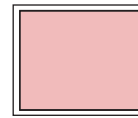

NG

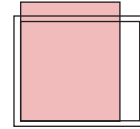

4 Close the front cover.

5 Turn the main power switch ON.

- (1) Set the main power switch located on the side of this machine to the "I" side.
 - When the power is turned on, the firmware version is displayed and the initial operation is executed.
- (2) Press the [END / POWER] key to turn on the power.

Male Connector Absorbent for MBIS

When replacing the 2L ink pack, you can prevent dirt from entering the cradle by periodically (5 to 10 times) replacing the male connector absorbent (accessory).



- Be sure to wear the supplied safety glasses and gloves when replacing the male connector absorbent.



- When the accessories are finished, please purchase from your local dealer or our sales office. (PN:SPA-0625)

1 Push down the lever attached to the cradle, and remove the 2L eco-case.

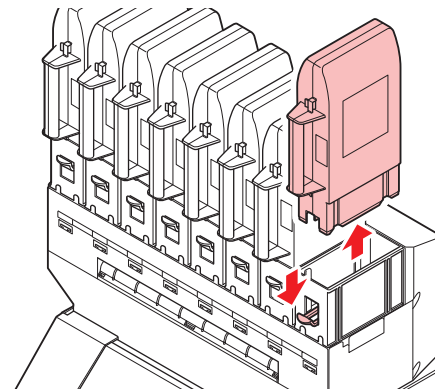

2 Remove the male connector absorbent.

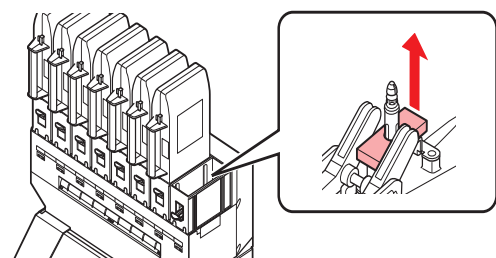

3 Insert the new male connector absorbent.

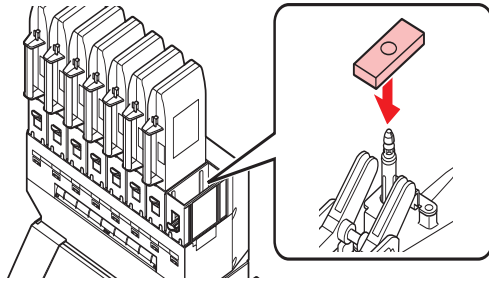

4 Install the 2L eco-case.

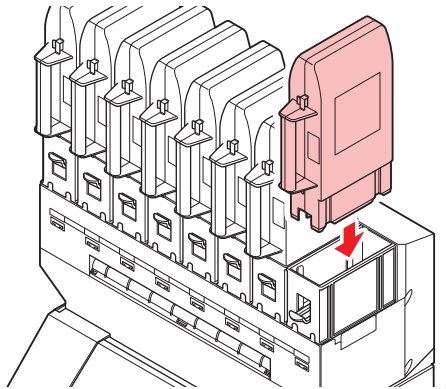

Replacing the Blow down fan filter

When the Blow down fan filter (PN: SPC-0856) becomes dirty, or the warning message "Replace the Blow down fan filter" appears on the display, check and replace the Blow down fan filter immediately. The replacement is about once every three months.

1 Remove the fan filter cover.

- Push the fan filter cover's tab outward, and pull the cover out toward you.

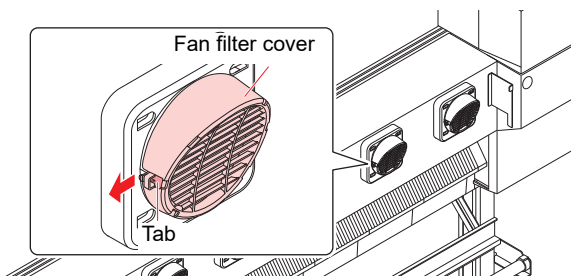

2 Remove the Blow down fan filter.

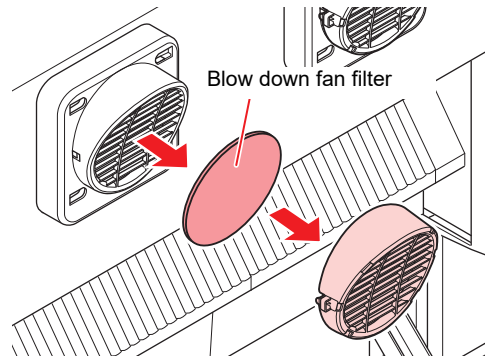

3 Attach a new Blow down fan filter and return the fan filter cover.

- Fit the fan filter cover on firmly, so that it clicks into place.

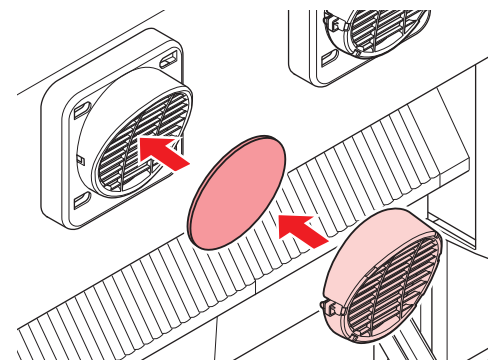

Replacing the Cutter Blade

The cutter is a consumable product. When the cutter blade gets dull, replace it with a new one (PN:SPA-0107).



- The blade is sharp. Be careful not to hurt yourself or anyone else.
- Store the cutter blade in a place that is out of the reach of children. Dispose of the used cutter blade in compliance with applicable regulations.



- When replacing the cutter blade, it is recommended to place a sheet of paper under the cutter blade. This will help you to pick up the cutter blade if it drops.

1 In LOCAL mode, select [MENU] > [MAINTENANCE], then press the [ENTER] key.

- The Maintenance menu is displayed.

2 Select [STATION MAINT.] > [CARRIAGE OUT] > [Move To Platen Right End], then press the [ENTER] key.

- The carriage moves over the platen.

3 Open the front cover.

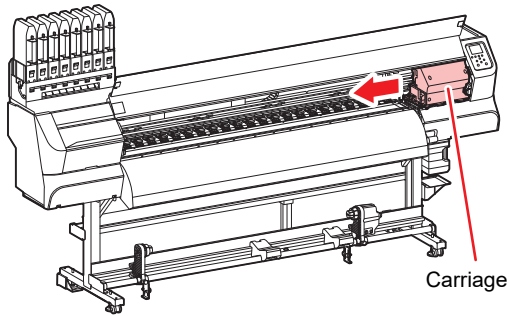

Carriage

4 Replace the cutter unit next to the carriage.

- (1) Loosen the screw of the cutter unit.
- (2) Remove the cutter unit.
- (3) Mount a new cutter unit.
- (4) Fasten the screw of the cutter unit to secure the cutter unit.

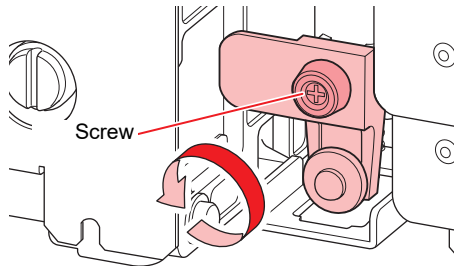

Screw

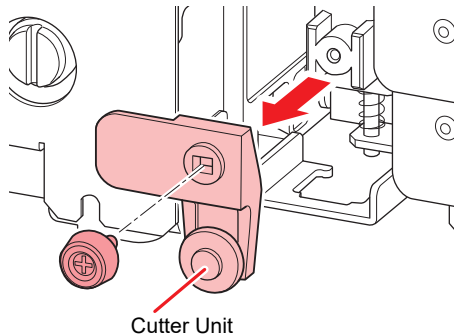

Cutter Unit

5 Close the Front cover.

6 Press the **ENTER** key.

Media edge guide film replacement

Replace the media edge guide film if it is creased or worn.

- 1 Remove the media from the take-up unit.
- 2 Remove the media edge guide film from the media edge guide.



- Make sure no parts of the double-sided tape remain.

- 3 Remove the double-sided tape on the media edge guide film and attach it to the media edge guide.

- Align and attach the film hole (×2) to the screw hole (×2) of the media edge guide.

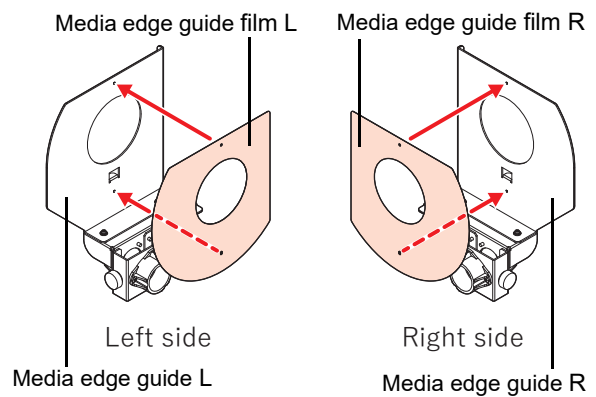

Waste ink tank management

Correction of waste ink amount

If an error occurs between the count value of the waste ink tank and the actual volume, perform error correction.

- 1** In LOCAL mode, select [MENU] > [MAINTENANCE], then press the [ENTER] key.
 - The Maintenance menu is displayed.
- 2** Select [Waste ink tank], then press the [ENTER] key.
 - Waste ink tank information is displayed.
- 3** Select [Adjust Waste Ink Volume], press the [ENTER] key.
 - **Setting value:** 2 to 10 L

Change of tank capacity

If you installed a waste ink tank (2 L to 10 L tank) using the waste solution expansion kit (SPA-0311), change the tank capacity according to the capacity of the installed waste ink tank.



- If you have installed a waste ink tank using the waste solution expansion kit, display a "Check Waste Ink" message will be displayed at 80%, and a "Replace Waste Ink Tank" message will be displayed at 90% and the operation will be restricted.

- 1** In LOCAL mode, select [MENU] > [MAINTENANCE], then press the [ENTER] key.
 - The Maintenance menu is displayed.
- 2** Select [Waste ink tank], then press the [ENTER] key.
 - Waste ink tank information is displayed.
- 3** Select [Tank capacity], select the setting value, and press the [ENTER] key.

If a Waste Ink Tank Confirmation Message Appears

Ink that is used for head cleaning is collected in the waste ink tank on the bottom right side of this machine. This machine keeps track of the total volume of ink that is discharged, and displays a confirmation message when a certain volume is reached. **(When this message is displayed, you should think about replacing the waste ink tank.)**



- The "Replace Waste Ink Tank" message is displayed at 80% (1.6 L) for the standard 2 L tank.

Confirmation Message in LOCAL

- 1** The warning message "Check waste ink" is indicated on the display.
- 2** Check the waste ink tank.
 - If the actual volume is not displayed correctly, perform the operation in Step 3.
 - If the actual volume is displayed correctly, replace the waste ink tank.
When you replace (dispose of) the waste tank ink, perform the procedure in "Replace the waste ink tank with another". (P.4-26)
- 3** In LOCAL mode, select [MENU] > [MAINTENANCE], then press the [ENTER] key.
 - The Maintenance menu is displayed.
- 4** Select [Waste ink tank], then press the [ENTER] key.
 - Waste ink tank information is displayed.
- 5** If it is necessary to adjust the amount of waste ink, select [Adjust Waste Ink Volume] and press the [ENTER] key.
- 6** Adjust the level, press the [ENTER] key.

Replace the waste ink tank with another

If the waste ink tank becomes full, use the following procedure to replace the waste ink tank with another, and set the waste ink information in the maintenance menu to 0%.

If you replace the waste ink tank before the waste ink tank confirmation message is displayed (before the 2L tank is 80% (1.6L) full, use the same procedure to replace the waste ink tank.

- 1** In LOCAL mode, select [MENU] > [MAINTENANCE], then press the [ENTER] key.
- 2** Select [Reset Waste Ink Volume], then press the [ENTER] key.
 - Waste ink tank information is displayed.
- 3** Follow the instructions displayed on the screen to replace the waste ink.
- 4** Press the [ENTER] key.
 - The waste ink tank amount that is managed in this machine will be reset.
- 5** Pull the waste ink tank stopper to the front.

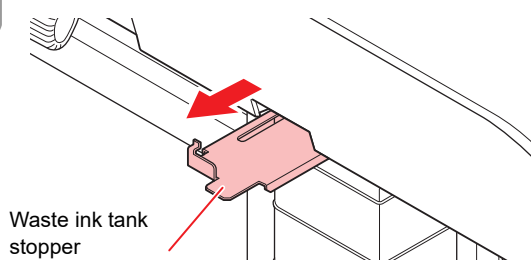

6 Pull it to the front to remove it by holding the waste ink tank handle.

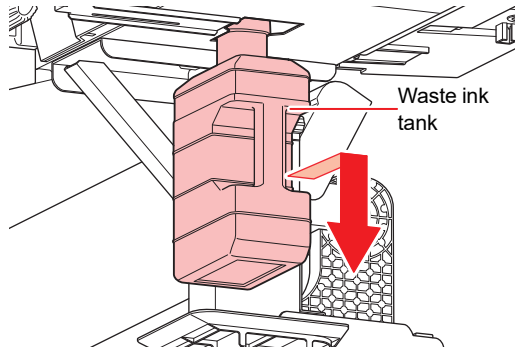

- Put a cap on the waste ink tank removed.

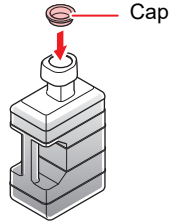

7 Replace the waste ink tank.

- (1) Prepare a new waste ink tank (PN:SPA-0246).
- (2) Insert the waste ink tank by holding the handle of the tank.

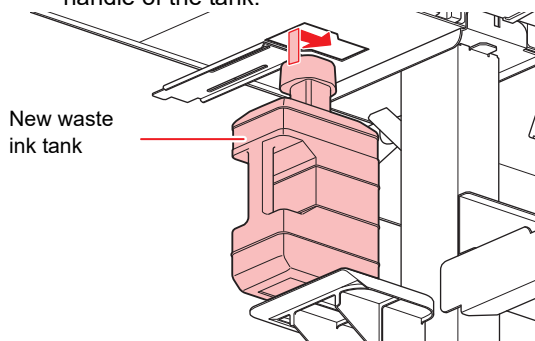

- Contact an industrial waste disposal company to request disposal of waste ink.

8 Close the waste ink tank stopper.

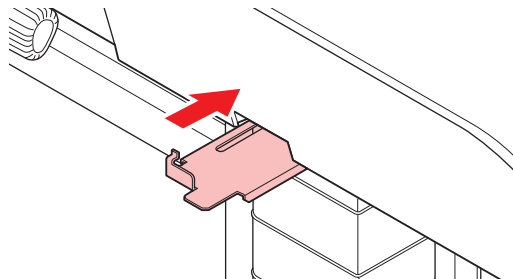

9 Press the **ENTER** key.

- The ink discharging amount that is controlled by the machine is reset and the message is canceled.

Chapter 5

Troubleshooting



This chapter

describes the corrective measures to be taken for a phenomenon suspected to be trouble and the procedures to clear the error number displayed on the LCD.

Troubleshooting	5-2
Power does not turn on	5-2
The machine does not start printing	5-2
Media get jammed / media is soiled	5-2
The heater's temperature will not rise to the set level	5-3
Image quality is poor	5-3
Nozzle is clogged	5-3
If an abnormality occurs in the state of the ink	5-3
When the ink leakage occurs	5-4
Warning / Error Messages	5-5
Warning messages	5-5
Error message	5-11

Troubleshooting

Take appropriate actions as described below before taking the trouble as a failure.

If still the problem is not solved after troubleshooting, contact your dealer or an office of MIMAKI.

Power does not turn on

In most cases, this is due to improper connection of the power cable for the machine or computer. Check that the power cable is connected properly.

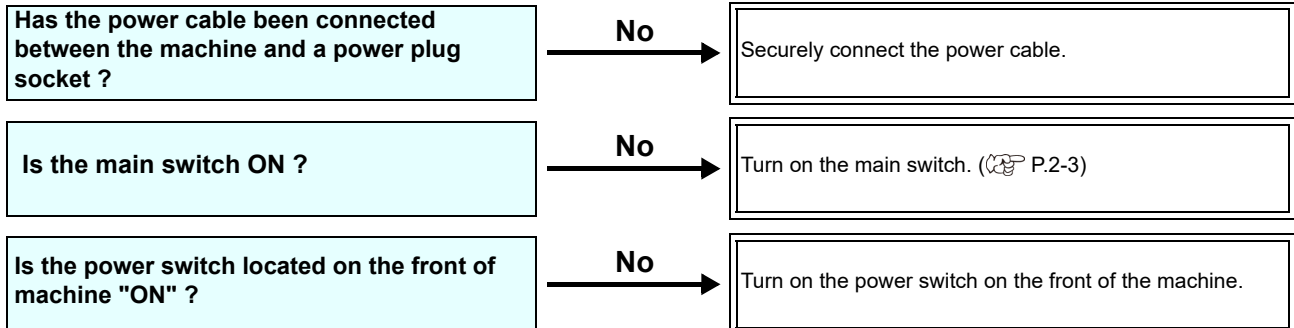

The machine does not start printing

This occurs when the data is not being transmitted to the machine properly.

It can also occur when the printing function does not work properly or the media is not set correctly.

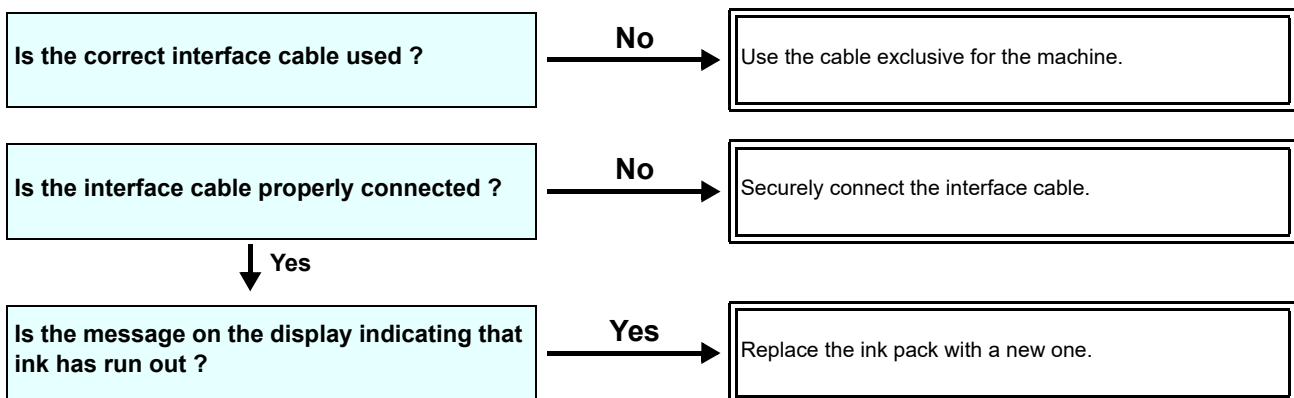

Media get jammed / media is soiled

Media jamming or stained media is considered to be due to the use of an unsuitable media or improper setting of media.

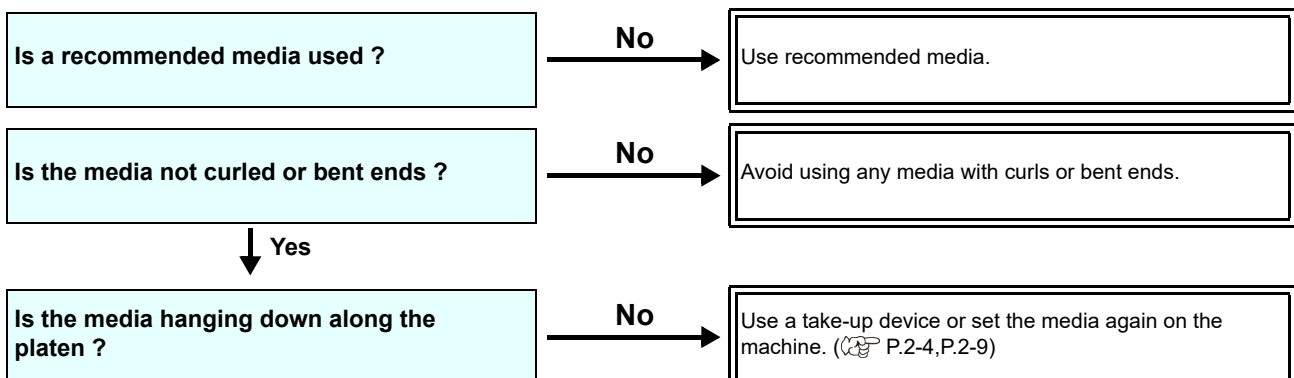

The heater's temperature will not rise to the set level

Check the basic operation.

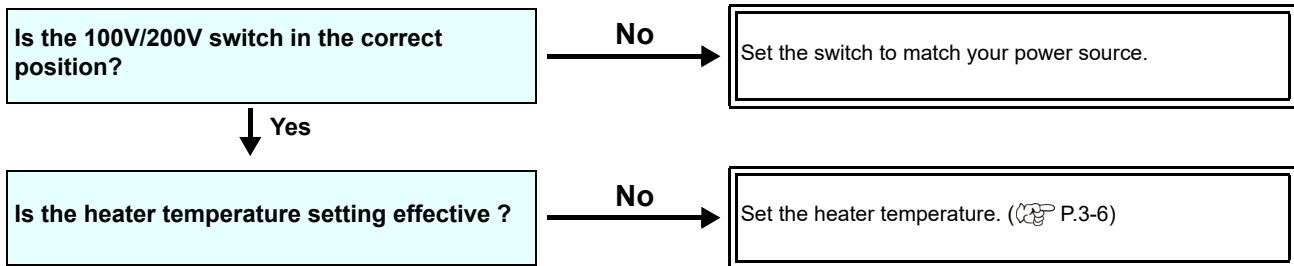

Image quality is poor

This section describes the corrective actions to be taken in case the image quality is not satisfactory.

Take remedy for particular problems with image quality. If the remedy does not work, contact your dealer or an office of MIMAKI.

Phenomenon	Measures
White lines / blur / dark stripes (in the direction of travel of the heads)	(1) Execute the head cleaning. (☞ P.2-12) (2) Perform maintenance of the inside of the station. (☞ P.4-7) (3) Execute the [FEED COMP.] function. (☞ P.3-4) (4) If any pieces of paper or dust is attached on the path of the heads such as media press, remove it.
Characters are double- or triple-printed in the media feed direction	(1) Execute the [FEED COMP.] function. (☞ P.3-4)
Disagreement in print positions between outward trip and homeward trip	(1) Execute the [DROP POSITION] function. (☞ P.3-5)
Ink drops falling on media during printing	(1) Execute the wiper cleaning. (☞ P.4-7) (2) Execute the ink cap cleaning. (☞ P.4-7) (3) Clean around the head. (☞ P.4-12) (4) Execute the head cleaning [NORMAL]. (☞ P.2-12)

Nozzle is clogged

Press the [END / POWER] key to turn on the power. If the nozzle clogging does not resolve even if cleaning the head with the operation on P.2-12, check the following items.

- Wash the head nozzle by the operations of P.4-9.
- Wash the head nozzle surface by the operations of P.4-12.
- Replace the wiper of P.4-16.
- Recovery the nozzle by the operations of P.4-14.

If an abnormality occurs in the state of the ink

When an abnormality occurs in the ink condition, the LED "Red" lights and a warning message is displayed.

All operations related to ink ejection such as printing and cleaning can not be performed.

Please promptly change to a new ink pack.



- Once ink trouble is displayed, do not leave the ink pack without replacing it for a long time; otherwise, the machine will lose the nozzle clogging prevention function.

If nozzles are clogged, the machine must be repaired by MIMAKI's service engineer.

Displaying the description of ink IC trouble

The contents of IC error are confirmable by the following operations.

- 1** Press the **ENTER** key in LOCAL.
- 2** Press the **ENTER** key.

When the ink leakage occurs

In case of ink leakage, please turn off the main power, unplug the power cable and contact your local distributor, our sales office, or service center.

Warning / Error Messages

If some trouble occurs, the buzzer sounds and the display shows a corresponding error message. Take an appropriate measure for the displayed message.

Warning messages

Error displaying information

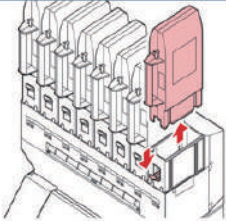
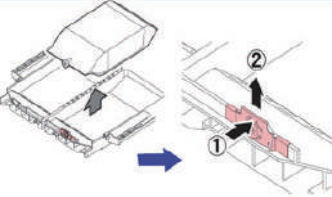

Illustration	Display	Measures
	Set Cartridge Set Ink IC	<ul style="list-style-type: none"> • It is an ink end. Replace the ink pack and ink IC chip. • Replace the ink IC chip with a normal one.
	<p><Alternate display 1> Please replace all spout rubber according to the explanation of eco case</p> <p><Alternate display 2> Degraded rubber will cause ink leak from the ink pack</p>	<ul style="list-style-type: none"> • Replace spout rubber of eco-case.
	Shake Ink Pack [ENT]	<ul style="list-style-type: none"> • Shake the ink pack and stir the ink.
	Please check media presses [ENT]	<ul style="list-style-type: none"> • Set the media retainer to the correct position. • Feed media so that there is no print result at the position where the media detection sensor passes. • Change to MENU> MACHINE SETUP MENU> MEDIA DETECT> Detect Speed = "Standard".

Illustration	Display	Measures
	<p><Alternate display 1> Please replace wash liquid cartridge</p> <p><Alternate display 2> No washing liquid will cause cleaning failure</p>	<ul style="list-style-type: none"> • Replace the maintenance washing liquid cartridge. • Set the maintenance washing liquid cartridge.
	<p>Replace Wiper</p>	<ul style="list-style-type: none"> • Replace the wiper. (MAINTENANCE MENU> STATION > REPLACE WIPER)
	<p>Stir the ink in the 10kg ink tank [ENT]</p>	<ul style="list-style-type: none"> • Stir the ink in the 10kg ink tank.
	<p>Ext.heater removed Please check connection</p>	<ul style="list-style-type: none"> • Check the connection status of the extension heater.
	<p>Can't rise in temperature Please check power supply</p>	<ul style="list-style-type: none"> • Check the power switch of the extension heater.

Illustration	Display	Measures
	Please set the ext.heater to the correct position	<ul style="list-style-type: none"> • Check the position of the extension heater. (make sure to set correct vertical position, and not set in halfway position)
	Wash the Blow down fan filter [ENT]	<ul style="list-style-type: none"> • Remove the fan filter cover and wash (wash it with water) the Blow down fan filter. Be sure to let the fan filter dry before installing it in the unit.
	Replace the Blow down fan filter [ENT]	<ul style="list-style-type: none"> • Remove the fan filter cover and replace the Blow down fan filter.

Errors when performing operations

Display	Cause	Measures
Invalid Operation !Cover Open	The function cannot be executed because the cover is open.	<ul style="list-style-type: none"> • Execute the operation after closing the cover.
Invalid Operation !Media Undetected	Operation cannot be performed because no media is detected.	<ul style="list-style-type: none"> • Execute after media is detected.
Invalid Operation !No Media	Operation cannot be performed because media is not set.	
Invalid Operation !Data Remain	The function cannot be executed because the data is being received.	<ul style="list-style-type: none"> • Execute the operation after executing data clear.
Invalid Operation Replace Waste Ink Tank	The waste ink tank count exceeded the specified amount (90%).	<ul style="list-style-type: none"> • Check the amount of ink in the waste ink tank. • Reset the count after correcting error or replacing the waste ink tank.
Invalid Operation !Ink Error	The function cannot be executed because an ink error has occurred.	<ul style="list-style-type: none"> • Execute the function after replacing the ink pack or 10kg ink tank and ink IC chip.
INK NEAR END 1_-----	The function cannot be executed because an ink near-end has occurred. (Routes with UISS are displayed when both inks are near-ended.)	
Invalid Operation !Connect 10kg Supply Unit	10kg The function cannot be executed because the supply unit is not connected.	<ul style="list-style-type: none"> • Restart the unit. If displaying again, contact your local distributor, our sales office, or service center.

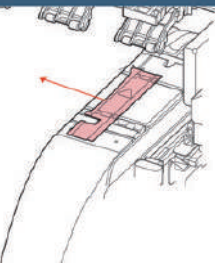
Display	Cause	Measures
Invalid Operation Take-up LimitDetect	The function cannot be executed, since the upper limit of the take-up tension bar position is detected.	<ul style="list-style-type: none"> Lower the take-up tension bar and then execute the function.
Invalid Operation Feeding LimitDetect	The function cannot be executed, since the upper limit of the feeding tension bar position is detected.	<ul style="list-style-type: none"> Execute the function after lowering the feeding tension bar.
Invalid Operation Take-up Wrong	The function cannot be executed, since the take-up tension bar is not moving from the lower limit position.	<ul style="list-style-type: none"> Execute the function after confirming that the take-up unit operates properly with the jog key.
Invalid Operation Feeding Wrong	The function cannot be executed, since the feeding tension bar is not moving from the lower limit position.	<ul style="list-style-type: none"> Execute the function after confirming that the take-up unit operates properly with the jog key.
Invalid Operation Take-up CoverOpen	The function cannot be executed because the cover of take-up unit is open.	<ul style="list-style-type: none"> Execute the operation after closing the cover of take-up unit.
Invalid Operation Feeding CoverOpen	The function cannot be executed because the cover of feeding unit is open.	<ul style="list-style-type: none"> Execute the operation after closing the cover of feeding unit.
Invalid Operation Take-up Connect	The function cannot be executed because the connection between take-up and feeding is reversed.	<ul style="list-style-type: none"> Restart the unit. If displaying again, contact your local distributor, our sales office, or service center.
Invalid Operation Feeding Connect	The function cannot be executed because the connection between feeding and take-up is reversed.	
Invalid Operation Take-up Unit None	The function cannot be executed because the take-up unit is not connected.	
Invalid Operation Feeding Unit None	The function cannot be executed because the feeding unit is not connected.	
Invalid Operation Take-up EmerSW On	The function cannot be executed because the emergency stop switch of the take-up unit is pushed.	<ul style="list-style-type: none"> Execute the operation after releasing the emergency stop switch of the take-up unit.
Invalid Operation Feeding EmerSW On	The function cannot be executed because the emergency stop switch of the feeding unit is pushed.	<ul style="list-style-type: none"> Execute the operation after releasing the emergency stop switch of the feeding unit.
Invalid Operation Take-up Unit Power	The function cannot be executed because the normal state of the inverter of the feeding unit cannot be confirmed.	<ul style="list-style-type: none"> Execute the operation after restarting the unit and confirm that the inverter power supply of the take-up unit is in the normal state.
Invalid Operation Feeding Unit Power	The function cannot be executed because the normal state of the inverter of the feeding unit cannot be confirmed.	<ul style="list-style-type: none"> Execute the operation after restarting the unit and confirm that the inverter power supply of the feeding unit is in the normal state.
Invalid Operation Take-up Relay Welding	The function cannot be executed because there is a possibility that the relay of the take-up unit is broken.	<ul style="list-style-type: none"> Restart the unit. If displaying again, contact your local distributor, our sales office, or service center.
Invalid Operation Feeding Relay Welding	The function cannot be executed because there is a possibility that the relay of the feeding unit is broken.	
Invalid Operation Wiper Move Failure	The function cannot be executed because the wiper does not operate properly.	<ul style="list-style-type: none"> Clean the surroundings of the wiper and restart the device, then execute the function.

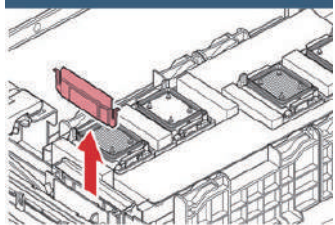
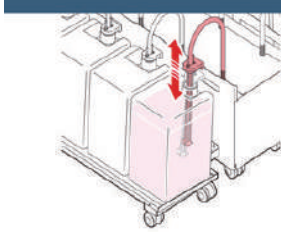
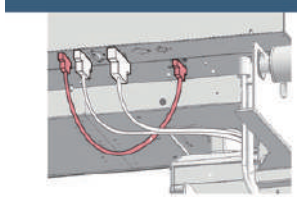
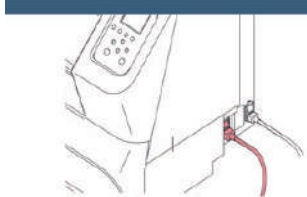
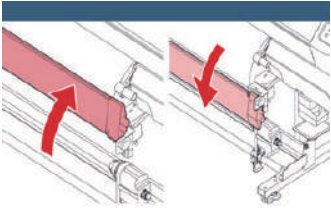
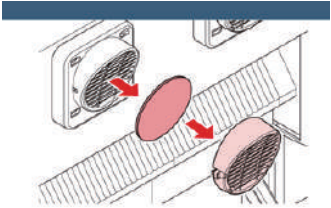
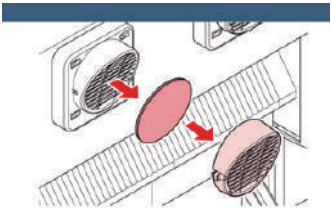
Message displayed in Local mode

Display	Cause	Measures
Lower the clamp lever	Clamp lever is raised.	<ul style="list-style-type: none"> Lower the clamp lever.

Display	Cause	Measures
Please set the media	No media is set.	<ul style="list-style-type: none"> Set the media.
Temporary Suspension	The state where printing is suspended.	<ul style="list-style-type: none"> Press the remote key to resume printing or execute data clear, and stop it.
Check Waste Ink	The count of the waste ink tank exceeds the specified amount (80%).	<ul style="list-style-type: none"> Check the amount of ink in the waste ink tank. Reset the count after correcting error or replacing the waste ink tank.
Replace Waste Ink Tank	The waste ink tank count exceeded the specified amount (90%).	<ul style="list-style-type: none"> Check the amount of ink in the waste ink tank. Reset the count after correcting error or replacing the waste ink tank.
!Can'tPrint/Ink IC	It is impossible to print, because the ink IC chip cannot be used.	<ul style="list-style-type: none"> Replace the ink pack or 10kg ink tank and ink IC chip.
Expiration Near M_____	The ink has expired (less than 2 months from expiration).	<ul style="list-style-type: none"> Replace the ink pack or 10kg ink tank and ink IC chip.
Ink Expiration Over M_____	The ink has expired (less than 2 months from expiration).	<ul style="list-style-type: none"> Replace the ink pack or 10kg ink tank and ink IC chip. (It can be used from the expiration date up to 2 months.)
Replace the Spout Rubber of Eco cartridge	Spout rubber of eco-case is time to replace	<ul style="list-style-type: none"> Replace the spout rubber of the eco case.
!Ink Remaining	Need to check because the remaining amount of the tank has become a little left. (The remaining ink level in the tank is less than 25%.)	<ul style="list-style-type: none"> Perform ink level correction as necessary.
!WashLiquidCart.None	Maintenance washing liquid cartridge is not set.	<ul style="list-style-type: none"> Set the maintenance washing liquid cartridge.
!Wash Liquid End	Maintenance washing liquid cartridge is empty.	<ul style="list-style-type: none"> Replace with a new maintenance washing liquid cartridge.
!Machine TEMP./H ** °C	The ambient temperature is higher than the usable temperature of the equipment.	<ul style="list-style-type: none"> Adjust the room temperature to the usable temperature (20°C - 30 °C) because there is a possibility that normal print results may not be obtained due to adverse effects on ink discharge.
!Machine Temp./I ** °C	The ambient temperature is lower than the usable temperature of the machine.	
!Connect 10kg Supply Unit	The 10kg supply unit is not connected.	<ul style="list-style-type: none"> Restart the unit. If displaying again, contact your local distributor, our sales office, or service center.
Take-up LimitDetect	The upper limit of the take-up tension bar position is detected.	<ul style="list-style-type: none"> Lower the take-up tension bar.
Feeding LimitDetect	The upper limit of the feeding tension bar position is detected.	<ul style="list-style-type: none"> Lower the feeding tension bar.
Take-up Wrong	The take-up tension bar is not moving from the lower limit position.	<ul style="list-style-type: none"> Check that the take-up unit works properly with the jog key.
Feeding Wrong	The feeding tension bar is not moving from the lower limit position.	<ul style="list-style-type: none"> Check that the feeding unit works properly with the jog key.
Take-up CoverOpen	The cover of the take-up unit is open.	<ul style="list-style-type: none"> Close the cover of the take-up unit.
Feeding CoverOpen	The cover of the feeding unit is open.	<ul style="list-style-type: none"> Close the cover of the feeding unit.
Take-up Connect	The connection between take-up and feeding is reversed.	<ul style="list-style-type: none"> Restart the unit. If displaying again, contact your local distributor, our sales office, or service center.
Invalid Operation Feeding Connect	The connection between take-up and feeding is reversed.	
Take-up Unit None	The take-up unit is not connected.	
Feeding Unit None	The Feeding unit is not connected.	

Display	Cause	Measures
Take-up EmerSW On	The emergency stop switch of the take-up unit is pushed.	• Release the emergency stop switch of the take-up unit.
Feeding EmerSW On	The emergency stop switch of the feeding unit is pushed.	• Release the emergency stop switch of the feeding unit.
Take-up Unit Power	The normal state of the inverter of the take-up unit cannot be confirmed.	• Restart the unit and check that the inverter power supply of the take-up unit is in normal condition.
Feeding Unit Power	The normal state of the inverter of the feeding unit cannot be confirmed.	• Restart the unit and check that the inverter power supply of the feeding unit is in normal condition.
Take-up Relay Welding	There is a possibility that the relay of the take-up unit is broken.	• Restart the unit. If displaying again, contact your local distributor, our sales office, or service center.
Feeding Relay Welding	There is a possibility that the relay of the feeding unit is broken.	
Replace Wiper	The used count of wiper has exceeded the specified number.	• Execute maintenance, station maint. and replace wiper to replace the wiper.
Wiper Move Failure	The wiper does not operate normally.	• Clean around the wiper and restart the machine. If displaying again, contact your local distributor, our sales office, or service center.
!NCU Connect	The NCU is not connected. Normal value cannot be detected by sensor check of NCU.	• Restart the unit. If displaying again, contact your local distributor, our sales office, or service center.
!Replace NCU	The sensor sensitivity of the NCU is low. (* NCU not available)	• NCU replacement is required. Contact your local distributor, our sales office, or service center.
NCU Sens Adj Err H	NCU sensitivity adjustment has failed. (* NCU not available)	
NCU Sens Adj Err L	NCU sensitivity adjustment has failed. (* NCU not available)	
!Replace NCU Ink Pad	The discharge count of the NCU exceeds the specified amount. (* NCU available)	• It is necessary to replace the NCU ink pad. Contact your local distributor, our sales office, or service center.
!NCU Sensor Lv Low	The NCU sensor sensitivity is falling. (* NCU available)	• Replacement of the NCU is recommended. • Contact your local distributor, our sales office, or service center.
Check the pinch roller for dirt [ENT]	the pinch roller is time to replace.	• Check the pinch roller for wear and dirt, and replace it if you are concerned.

Ink Error

Ink error is displayed also in the local guidance. (☞ P.3-28)

Display	Cause	Measures
648 Non Ink IC	The ink IC chip is not inserted in the slot.	• Insert the ink IC chip into the slot where indicating a warning. • Make sure that the ink IC chip is correctly inserted. If a warning remains even after the ink IC chip is inserted in the slot, restart the machine. • If displaying again, contact your local distributor, our sales office, or service center.
635/636 Wrong Ink IC	Ink IC chip cannot be read correctly.	• Reinsert the ink IC chip where indicating a warning. If displaying again, contact your local distributor, our sales office, or service center.

Display	Cause	Measures
640 Excess Ink Usage	Because the ink IC chip was not exchanged along with pack replacement, The amount of ink IC chip used exceeded the specified amount.	<ul style="list-style-type: none"> Replace the ink pack or 10kg ink tank and ink IC chip of the slot, in which the warning is indicated.
674 Ink Type	The ink type of the ink IC chip is different from the filled ink.	<ul style="list-style-type: none"> Check the ink type of the slot in which the warning is indicated.
631 Ink Color	The ink color of the ink IC chip is different from the filled ink.	<ul style="list-style-type: none"> Check the ink color of the slot in which the warning is indicated.
63D Ink Near End	The ink in the ink pack or the 10kg ink tank is slightly left.	<ul style="list-style-type: none"> Ink will soon run out. Be careful.
63E Ink End	No ink remains in the ink pack or 10kg ink tank.	<ul style="list-style-type: none"> Replace the ink pack or 10kg ink tank and ink IC chip of the slot, in which the warning is indicated.
641/642 Expire On ** D	The ink has expired (less than 2 months from expiration).	
643 Expiration Over	The ink has expired (more than 2 months have passed since the expiration).	
617 SubtankSens	Sub tank sensor value cannot be detected normally.	<ul style="list-style-type: none"> Restart the machine. If displaying again, contact your local distributor, our sales office, or service center.
618 TankLevel H	Even when ink is consumed, the amount of ink in the sub tank is not reduced.	<ul style="list-style-type: none"> Restart the machine. If displaying again, contact your local distributor, our sales office, or service center.
63F TankLevel L	<ul style="list-style-type: none"> Failure occurs in ink suction. A lot of nozzle clogging has occurred. 	
61B Supply Ink	The specified amount of ink was not supplied (semi-auto / manual) with 10 kg ink supply.	<ul style="list-style-type: none"> Check that there is sufficient ink in the 10kg ink tank. Check that the ink supply pipe is properly set in the 10kg ink tank. Execute 10kg ink supply (semi-auto / manual). <p>If displaying again, contact your local distributor, our sales office, or service center.</p>
676 !Ink Remaining	Need to check because the remaining amount of the tank has become a little left. (The remaining ink level in the tank is less than 25%.)	<ul style="list-style-type: none"> Perform ink level correction as necessary.

Error message

When an error message is displayed, eliminate the error according to the chart below.

When displaying again, contact your dealer or an office of MIMAKI to call for service.

No.	Display	Cause	Measures
1	108 HD THERMIS[1234]	An error occurred in the head temperature control.	<ul style="list-style-type: none"> Turn off the power on the machine and turn it on after a while. If displaying again, contact your local distributor, our sales office, or service center.
2	108 HD CONNECT[1234]	An error occurred in the connection of the head.	
3	122 CHECK:SDRAM	An error occurred in the SDRAM.	
4	128 HDC FIFO OVER	An error occurred in the head control PCB.	
5	128 HDC FIFO UNDER		
6	129 BATTERY EXCHANGE	Detected battery exhaustion in internal clock.	<ul style="list-style-type: none"> Contact your local distributor, our sales office, or service center.

No.	Display	Cause	Measures	
7	12a HDC SPEED	Detected an error in the waveform for the printing.	<ul style="list-style-type: none"> • Turn off the power on the machine and turn it on after a while. If displaying again, contact your local distributor, our sales office, or service center. 	
8	130 HD DATA SEQ			
9	146 E-LOG SEQ	A sequential number error occurred in the event log.		
10	151 Main PCB V1R2	An error occurred in the power supply system of the main PCB.		
11	152 Main PCB V2R5			
12	153 Main PCB V3R3			
13	154 Main PCB V05			
14	157 Main PCB VTT			
15	16e Main PCB V3R3B			
16	15f HEAD DRIVE HOT			
17	171 NEW HEAD CONNECT	An error occurred in the power supply system of the main PCB.		
18	18a Main PCB V_CORE	An error occurred in the power supply of the main PCB.		
19	18c Main PCB V12			
20	18e FLS NOT COMP	Detected an error in the waveform for the printing.		
21	18f OFFSET START			
22	18f OFFSET END			
23	1d9 Main PCB V48-1	An error occurred in the power supply of the main PCB.		
24	b1b BaseIO PCB Vpow-s	An error occurred in the power supply of the BaseIO PCB.		
25	b1c BaseIO PCB V24			
26	b1d BaseIO PCB V24-A			
27	b3f BaseIO Unconform	The Base IO PCB was not recognized, or a PCB with limited functionality (LC product) is attached.		
28	b21 SLIDER1 PCB V3R3	An error occurred in the power supply of the slider M PCB.		
29	b22 SLIDER1 PCB V2R5			
30	b23 SLIDER1 PCB V1R8			
31	b24 SLIDER1 PCB V1R2			
32	1e6 PRAM Size Shortage	Memory size is insufficient.		
33	201 COMMAND ERROR	Data other than print data was received. Or, an error occurred in the transmitted print data.		<ul style="list-style-type: none"> • Securely connect the interface cable. Use an interface cable conforming to the standard.
34	202 PARAMETER ERROR	An error occurred in the transmitted print data.		

No.	Display	Cause	Measures
35	206 PRINTING MODE	The machine received print data with unprintable conditions.	<ul style="list-style-type: none"> • Check the print data output condition of the RIP software. • Check the profile. • If displaying again, contact your local distributor, our sales office, or service center.
36	304 USB INIT ERR	An error occurred in the USB communication.	<ul style="list-style-type: none"> • Turn off the power on the machine and turn it on after a while. • If displaying again, contact your local distributor, our sales office, or service center.
37	305 USB TIME OUT		
38	307 MCFD File IF Error	An error occurred while accessing the printing condition data.	<ul style="list-style-type: none"> • Turn off the power on the machine and turn it on after a while. • If displaying again, contact your local distributor, our sales office, or service center.
39	401 MOTOR X	An excessive load was applied to the X motor.	
40	402 MOTOR Y	An excessive load was applied to the Y motor.	<ul style="list-style-type: none"> • Turn off the power on the machine and turn it on after a while. • If displaying again, contact your local distributor, our sales office, or service center.
41	403 X CURRENT	Overcurrent error of X motor was detected.	
42	404 Y CURRENT	Overcurrent error of Y motor was detected.	
43	44f Take-up Roll Sns Err	Take-up roller sensor error The roller sensor cannot be correctly read.	<ul style="list-style-type: none"> • Make sure that take-up unit and take-up tension bar settings in the machine setting are "ON". (☞ P.3-15) • Check the set condition of the media. • Confirm that the take-up unit operates using the manual SW.
44	48a Detect Winding Failure	Detect Winding Failure • The small take-up unit can not take-up the media correctly	<ul style="list-style-type: none"> • Check the status of the media set. • If the media has not been taken-up, reset it properly.
45	505 MEDIA JAM	A media clogging occurred.	<ul style="list-style-type: none"> • Remove the media and reset it.
46	509 HDC POSCNT	An error occurred in the position control.	<ul style="list-style-type: none"> • Turn off the power on the machine and turn it on after a while. • If displaying again, contact your local distributor, our sales office, or service center.
47	50a Y ORIGIN	Y origin could not be detected.	
48	50f L-SCALE BLACK	Abnormal linear scale.	
49	50c MEDIA WIDTH SENSOR	The media width could not be correctly read.	<ul style="list-style-type: none"> • Check the media set position. (☞ P.2-4) • Clean the media sensor. (☞ P.4-3) • Turn off the power on the machine and turn it on after a while.
50	516 MEDIA SET POSITION R	The media is set out of range.	<ul style="list-style-type: none"> • Check the media set position. (☞ P.2-4)
51	528 PUMP MOTOR SENSOR	Pump sensor detection error.	<ul style="list-style-type: none"> • Turn off the power on the machine and turn it on after a while. • If displaying again, contact your local distributor, our sales office, or service center.
52	52f CARRIAGE ORG	The control origin position of the carriage is not set.	<ul style="list-style-type: none"> • Contact your local distributor, our sales office, or service center.
53	530 STATION ORG	The control origin position of the station is not set.	
54	536 STATION LOCK	An error of the station operation was detected.	<ul style="list-style-type: none"> • Turn off the power on the machine and turn it on after a while. • If displaying again, contact your local distributor, our sales office, or service center.

No.	Display	Cause	Measures
55	608 WRONG INK IC	Ink IC chip of the ink pack cannot be read correctly.	<ul style="list-style-type: none"> • Make sure that the ink IC chip is correctly inserted. • Reinsert the ink IC chip. • Turn off the power on the machine and turn it on after a while. If displaying again, contact your local distributor, our sales office, or service center.
56	627 RE-INSERT CARTRIDGE	There is a slot in which the ink IC chip is not inserted for more than a certain time.	<ul style="list-style-type: none"> • Set an ink IC chip.
57	628 WRONG INK CARTRIDGE	An error occurred in the information of the ink IC chip of the ink pack. The usage exceeds the specified value.	<ul style="list-style-type: none"> • Check that the nozzle is not clogged.
58	63c INK REMAIN ZERO	Cartridge remaining amount 0 (ink end / only at 4-color ink set)	<ul style="list-style-type: none"> • Replace with new ink.
59	64C NCU ERROR	The nozzle check was interrupted due to some problem.	<ul style="list-style-type: none"> • Turn off the power on the machine and turn it on after a while. If displaying again, contact your local distributor, our sales office, or service center.
60	650 NCU CONECT	The NCU unit is not connected.	<ul style="list-style-type: none"> • Turn off the power on the machine and turn it on after a while. If displaying again, contact your local distributor, our sales office, or service center.
61	651 REPLACE NCU	The NCU sensor sensitivity is too low to correctly judge missing lines (due to nozzle clogging). The nozzle check function cannot be used.	<ul style="list-style-type: none"> • NCU replacement is required. Contact your local distributor, our sales office, or service center.
62	652 NCU NZK CHK (HW)	Nozzle clogging and deflection occur frequently, And the NCU cannot correctly recognize the ink discharge.	<ul style="list-style-type: none"> • Check the nozzle condition. If there is a great amount of missing lines (due to nozzle clogging) or deflection, clean the affected nozzles.
63	653 NCU NZK CHK (MARK)		
64	654 NCU CENTER POS		
65	655 NCU FLUSH POS		
66	656 NCU SN ADJUST	Sensor sensitivity adjustment has failed.	<ul style="list-style-type: none"> • Check the nozzle condition. If there is a great amount of missing lines (due to nozzle clogging) or deflection, clean and restore the affected nozzles. If displaying again, contact your local distributor, our sales office, or service center.
67	657 REPLACE NCU INK PAD	Ink absorbent of NCU is full.	<ul style="list-style-type: none"> • Contact your local distributor, our sales office, or service center.
68	658 NCU SENSOR LV LOW	The NCU sensor sensitivity is falling.	<ul style="list-style-type: none"> • Replacement of the NCU is recommended. Contact your local distributor, our sales office, or service center.
69	65b NCU Sens Adj Err H	Cannot adjust the sensor sensitivity.	
70	65c NCU Sens Adj Err L		
71	702 THERMISTOR CONNECT	A thermistor connection error has occurred.	<ul style="list-style-type: none"> • Turn off the power on the machine and turn it on after a while. If displaying again, contact your local distributor, our sales office, or service center.
72	710 HEATER TEMP ERROR	Heater temperature abnormality was detected. If the temperature abnormality cannot be resolved after this error occurred, forcibly turn off the machine power.	
73	901 INVAILD OPERATION	Due to a certain error, the function cannot be performed.	<ul style="list-style-type: none"> • Return to the local mode screen and check the error situation and take appropriate action.
74	902 DATA REMAIN	There is remaining print data.	<ul style="list-style-type: none"> • Clear the data. (P.2-15)

No.	Display	Cause	Measures
75	90d NO HEAD SELECT	An error occurred in the mounted heads.	<ul style="list-style-type: none"> Turn off the power on the machine and turn it on after a while. If displaying again, contact your local distributor, our sales office, or service center.
76	90f PRINT AREA SHORT	Media width or media length required for printing is insufficient.	<ul style="list-style-type: none"> Change the media to the one with enough width or length. When the media width narrows because the origin moved, slide the origin to the right to widen the effective media width.
77	91a ADJUST HEAD HEIGHT	There is a difference between the head height set value stored in the machine and the current head height.	<ul style="list-style-type: none"> Set the head height. (☞ P.2-4)
78	04 PARAM ROM	An error occurred in the MAIN PCB FROM.	<ul style="list-style-type: none"> Turn off the power on the machine and turn it on after a while. If displaying again, contact your local distributor, our sales office, or service center.
79	d09 HD MEMORY [1234]	An error was detected in the built-in head memory.	

SYSTEM HALT

Message	Solution
SYSTEM HALT (*) 000 : MESSAGE	<ul style="list-style-type: none"> Turn off the power on the machine and turn it on after a while. When displaying again, check the number and contact your local distributor, our sales office, or service center. ("000" is the error No.)

Chapter 6

Appendix



This chapter

contains the lists of the specifications and functions of this machine.

Specifications	6-2
Machine specifications	6-2
Ink specifications	6-3
Setting orders depending on ink type	6-4
Setting orders of ink cartridges	6-4
Sheet for inquiry	6-5
LICENSE Library	6-6

Specifications

Machine specifications

Item		TS55-1800	
Print head	Method	Drop-on-demand piezoelectric print heads	
	Specification	Two head units (420 nozzles x 8 rows)	
Printing mode (scan x feed)		360×360dpi/ 480×600dpi/540×360dpi/ 600×600dpi/720×600 ^{*1} / 720×720dpi/ 720×1080dpi	
Usable inks		9 colors (Y, M, BI, K, LBI, Lm, Lk, FP, FY)	
Ink supply		Supplying from ink packs through tubes. Ink pack replacement type: Supplying by Toggle switch over with 2 packs/color (4-colors/6-colors ink set: M, BI 7colors ink set: M)	
Capacity of ink pack	4-colors	Y, M, BI, K: 2L-ink pack x 2 for each color	
	6-colors	Y, K, LBI, Lm: 2L-ink pack x 1 for each color M, BI: 2L-ink pack x 2 for each color	
	7-colors	Y, K, BI, LBI, Lm, Lk: 2L-ink pack x 1 for each color M: 2L-ink pack x 2	
	8-colors	Y, M, BI, K, LBI, Lm, FP, FY: 2L-ink pack x 1 for each color	
Usable media	Type	Transfer paper	
	Max. printing width	1,940 mm (76.4 in)	
	Maximum	1,950 mm (76.8 in)	
	Minimum	210 mm (8.3 in)	
	Thickness	1.0 mm or less (0.04 in or less)	
	Printing surface	Side facing outward	
	Feed	Roll outside diameter ^{*2}	Φ250 mm or less (Φ9.8 in or less)
		Roll weight ^{*2, *3}	45 kg or less (88.2 lb or less)
		Roll inside diameter	2 or 3 inches
	Take-up	Roll outside diameter ^{*2}	When not using the Media edge guide.: Φ250 mm or less (Φ9.8 in or less) When using the Media edge guide.: Φ200mm to Φ120mm or less (depending on the mounting position of the Media edge guide)
		Roll weight ^{*2, *3}	45 kg or less (88.2 lb or less)
		Roll inside diameter	2 or 3 inches
		Roll end treatment	The roll end is gently fixed to the core with weak-adhesive tape or weak glue for easy removal.
Winding misalignment	~ Φ120 mm(4.8 in) : ± 1 mm(0.04 in) ~ Φ170 mm(6.7 in) : ± 3 mm(0.12 in) ~ Φ 200mm(7.9 in) : ± 5 mm(0.2 in) (When using the Media edge guide)		
Margin	Roll media	Left end and right end: 15 mm (Default) Front: 120 mm Rear: 150 mm (Left end and right end: 0.6 in (Default) Front: 4.7 mm Rear: 5.9 mm)	
Distance accuracy	Absolute accuracy	Whichever the larger one of ± 0.3 mm or ± 0.3% of the designated (Whichever the larger one of ± 0.01 in or ± 0.3% of the designated)	
	Reproducibility	Whichever the larger one of ± 0.2 mm or ± 0.1% of the designated (Whichever the larger one of ± 0.008 in or ± 0.1% of the designated)	
Perpendicularity		± 0.5 mm / 1,000 mm (± 0.02 in / 39.4 in)	
Media skew		5 mm or less / 10 m (0.2 in or less / 32.8 ft)	
Head height adjustment		Low (2.8mm) / Mid (3.3mm) / High (3.8mm) (Low (0.11 in) / Mid (0.13 in) / High (0.15 in))	
Cutting of media		Cutting of Y direction by the head cutter. Cutting accuracy (steps): 0.5 mm or less (0.02 in or less)	
Media delivery		Take-up device supplied as a standard accessory (switching possible between face in and face out).	

Item		TS55-1800
Waste ink tank		Bottle type: 2,000 cc (2 liters)
Interface	Print data transmission function	USB 2.0 Hi-speed, Ethernet 1000BASE-T
	Mail function	Ethernet 10 BASE-T / 100 BASE-TX / 1000BASE-T
Command		MRL- V
Noise	during standby	Less than 58 dB (A) (FAST-A, Front & Rear & Left & Right 1 m (39.4 in))
	during continuous printing	Less than 65 dB (A)
	during discontinuous printing	Less than 70 dB (A)
Safety Standard		VCCI-Class A, FCC-Class A, ETL conforming to IEC 62368-1, UL 60950, CE Marking (EMC, Low Voltage Directive, Machinery Directive, RoHS Directive), CB Report, RoHS, Energy Star, RCM, EAC
Power		Single-phase AC100 - 120V/ 200 - 240V 12A/8A 50/60Hz
Power consumption		1440 W or less (AC 100 - 120 V), 1920 W or less (AC 200 - 240 V)
Recommended Environment	Available temp.	20 °C to 30 °C (68 °F to 86 °F)
	Humidity	35 to 65% Rh (No condensation)
	Guaranteed temp.	20 °C to 25 °C (68 °F to 77 °F)
	Temperature change	± 10 °C / h or less (± 50 °F / h or less)
	Dust	Equivalent to normal office level
	Highest operation height	2,000 m (6,561.7 ft)
Weight		202 kg (445.3 lb)
Outside dimensions	Width	3,240 mm (127.6 in)
	Depth	713 mm (28.1 in)
	Height	1,857 mm (73.1 in)

*1. Not compatible with 6, 7 and 8 color ink sets.

*2. It is outside diameter and weight after take-up media.

*3. Without deflection of the roll when it is retained at both ends.

Ink specifications

Item		Sublimation dye ink
Supply		2 liters ink pack
Color		Black ink pack (B) Blue ink pack (BI) Magenta ink pack (M) Yellow ink pack (Y) Light blue ink pack (LBI) Light magenta ink pack (Lm)
		Light black ink pack (Lk) Fluorescent yellow ink pack (FY) Fluorescent pink ink pack (FP)
Ink capacity		2 liters
Shelf life		The period is printed on the ink pack. Within one month after opening the package even in the available period.
Storage temperature	Storage	Average daily temperature: 10 to 35°C (50 to 95°F) Be sure to keep a vessel in the airtight condition. Be sure to keep a vessel in a dry, well-ventilated, cool and dark location.
	Transportation	0 to 40 °C (32 to 104 °F) Avoid the condition lower than -0 °C (32 °F) and higher than 40 °C (104 °F).



- Do not disassemble ink packs and 2L eco case and do not refill them with ink.
- Ink could freeze if kept in a cold place for an extended period.
- When aqueous ink is used, if the ink freezes, the quality is changed and the ink becomes unusable. Store the ink in an environment that will not freeze the ink.

Setting orders depending on ink type

The setting value and the setting orders of the ink cartridges differ depending on the ink type you use.

Setting orders of ink cartridges

The orders of ink cartridges set in the ink station differ depending on the ink set you use.



- Set the ink cartridge according to the cartridge label under the ink station.

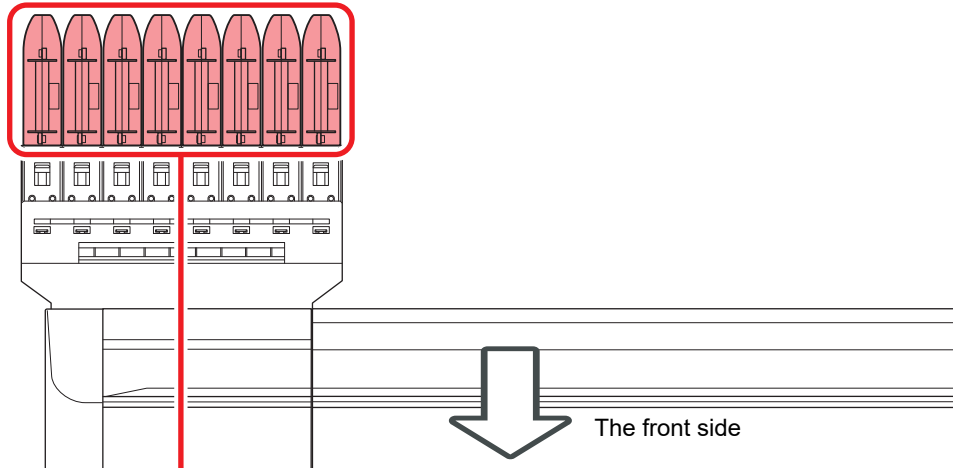

4-colors model	Sublimation dye ink	M	M	Bl	Bl	Y	Y	K	K
6-colors model	Sublimation dye ink	M	M	Bl	Bl	Y	Lm	K	Lbl
7-colors model	Sublimation dye ink	M	M	Bl	Lk	Y	Lm	K	Lbl
8-colors model	Sublimation dye ink	M	FP	Bl	FY	Y	Lm	K	Lbl

Sheet for inquiry

Use this sheet for troubles and abnormal functions of the machine.
Fill in the following necessary items, and then fax the sheet to our sales office.

Company name	
Person in charge	
Telephone number	
machine model	
Operating OS	
Machine information *1	
Error message	
Contents of inquiry	

*1. Refer to "Confirming Machine information" of "Convenient using" then fill in necessary information. (☞ P.3-27)

LICENSE Library

Mimaki printer Firmware

Copyright ©2020 MIMAKI ENGINEERING CO.,LTD. All rights reserved.

This product contain open source software listed in the tables below.

Component	License
StarterWare for ARM® based TI Sitara Processors	BSD-TI

The following license terms and conditions shall apply to the open source software listed in the table above:

BSD-TI

Copyright (C) 2010 Texas Instruments Incorporated - <http://www.ti.com/>

Redistribution and use in source and binary forms, with or without modification, are permitted provided that the following conditions are met:

1. Redistributions of source code must retain the above copyright notice, this list of conditions and the following disclaimer.
2. Redistributions in binary form must reproduce the above copyright notice, this list of conditions and the following disclaimer in the documentation and/or other materials provided with the distribution.
3. Neither the name of Texas Instruments Incorporated nor the names of its contributors may be used to endorse or promote products derived from this software without specific prior written permission.

THIS SOFTWARE IS PROVIDED BY THE COPYRIGHT HOLDERS AND CONTRIBUTORS "AS IS" AND ANY EXPRESS OR IMPLIED WARRANTIES, INCLUDING, BUT NOT LIMITED TO, THE IMPLIED WARRANTIES OF MERCHANTABILITY AND FITNESS FOR A PARTICULAR PURPOSE ARE DISCLAIMED. IN NO EVENT SHALL THE COPYRIGHT OWNER OR CONTRIBUTORS BE LIABLE FOR ANY DIRECT, INDIRECT, INCIDENTAL, SPECIAL, EXEMPLARY, OR CONSEQUENTIAL DAMAGES (INCLUDING, BUT NOT LIMITED TO, PROCUREMENT OF SUBSTITUTE GOODS OR SERVICES; LOSS OF USE, DATA, OR PROFITS; OR BUSINESS INTERRUPTION) HOWEVER CAUSED AND ON ANY THEORY OF LIABILITY, WHETHER IN CONTRACT, STRICT LIABILITY, OR TORT (INCLUDING NEGLIGENCE OR OTHERWISE) ARISING IN ANY WAY OUT OF THE USE OF THIS SOFTWARE, EVEN IF ADVISED OF THE POSSIBILITY OF SUCH DAMAGE.

TS55-1800 Operation Manual

May, 2021

MIMAKI ENGINEERING CO.,LTD.

2182-3 Shigeno-otsu, Tomi-shi, Nagano 389-0512 JAPAN

D203290-22-08052021

