

ENGLISH

**LK-1900S Series
INSTRUCTION MANUAL**

CONTENTS

I. EXPLANATION OF THE LK-1900S, COMPUTER-CONTROLLED HIGH- SPEED BARTACKING MACHINE.....	1
1. SPECIFICATIONS.....	1
2. CONFIGURATION.....	2
2-1. Names of main unit.....	2
2-2. Names and explanation of switches on the operation panel.....	3
3. INSTALLATION.....	4
3-1. Installing the electrical box.....	4
3-2. Installing the pedal sensor.....	4
3-3. Attaching the connecting rod.....	5
3-4. Installing the head support rod.....	5
3-5. Installing and connecting the power switch...	6
3-6. How to carry the sewing machine.....	7
3-7. Installation of the sewing machine head.....	7
3-8. Installing the drain receiver and the head support rubber.....	8
3-9. Safety switch.....	8
3-10. Tilting the sewing machine head.....	9
3-11. Installing the operation panel.....	9
3-12. Connecting the cords.....	10
3-13. Handling the cords.....	11
3-14. Installing the eye protection cover.....	12
3-15. Installing the thread stand.....	13
3-16. In the case the machine is transported after factory-completed at the time of shipment.....	13
4. OPERATION OF THE SEWING MACHINE .	14
4-1. Lubrication.....	14
4-2. Attaching the needle.....	14
4-3. Threading the machine head.....	15
4-4. Installing and removing the bobbin case.....	15
4-5. Installing the bobbin.....	16
4-6. Adjusting the thread tension.....	16
4-7. Adjusting the thread take-up spring.....	17
5. OPERATION OF THE SEWING MACHINE (BASIC).....	17
5-1. Selection of language.....	17
5-2. Setting the pattern number.....	18
5-3. Setting the item data.....	18
5-4. Checking the contour of a sewing pattern....	21
5-5. Sewing.....	22
5-6. Changing the pattern to a different one.....	22
5-7. Winding a bobbin.....	23
5-8. How to open the tension disk.....	24
5-9. LED hand light.....	25
6. OPERATION OF THE SEWING MACHINE (ADVANCED).....	26
6-1. Performing sewing using the pattern keys ..	26
6-2. Sewing using the combination function (cycle sewing).....	31
6-3. Sewing through the use of the counter.....	34
6-4. How to use the temporary stop.....	37
6-5. Copying or deleting various kinds of pattern data.....	38
6-6. Communication.....	40
6-7. Cautions in operation.....	42
6-8. Setting enable/disable of standard pattern invoking.....	43
6-9. How to use the F key.....	44
6-10. Production support function.....	45
7. MAINTENANCE.....	51
7-1. Adjusting the height of the needle bar.....	51
7-2. Adjusting the needle-to-shuttle relation.....	52
7-3. Adjusting the lift of the work clamp foot.....	53
7-4. The moving knife and counter knife.....	53
7-5. Adjustment of the wiper.....	54
7-6. Draining waste oil.....	54
7-7. Amount of oil supplied to the hook.....	55
7-8. Replacing the fuse.....	55
7-9. Replenishing the designated places with grease.....	56
7-10. Disposal of batteries.....	58
8. HOW TO USE THE MEMORY SWITCH.....	59
8-1. Method of changing memory switch data.....	59
8-2. List of the memory switch functions.....	60
9. OTHERS.....	63
9-1. Table of the standard pattern specifications	63
9-2. Table of the standard patterns.....	64
9-3. Table of the work clamp foot.....	66
9-4. Installing the foot pedal switch (optional)....	68
9-5. Error list.....	69
9-6. Message list.....	73
9-7. Troubles and corrective measures (sewing conditions).....	75
9-8. Table of the optional parts.....	77
II. EXPLANATION OF THE LK-1903S, COMPUTER-CONTROLLED HIGH- SPEED LOCKSTITCH BUTTON SEWING MACHINE.....	79
1. SPECIFICATIONS.....	79
2. PREPARATION OF THE SEWING MACHINE.....	79
2-1. Installation of the sewing machine and preparation of the operation.....	79
2-2. Needle and thread.....	79
2-3. Various sewing modes.....	80
3. ADJUSTMENT OF THE SEWING MACHINE.....	81
3-1. Position of the button clamp jaw lever.....	81
3-2. Adjusting the feed plate.....	82
3-3. Adjusting the button clamp jaw lever.....	83
3-4. Adjusting the lifting amount of the button clamp.....	83
3-5. Adjustment of the pressure of the work clamp unit.....	84
3-6. Adjustment of the wiper spring.....	84
4. OTHERS.....	85
4-1. Installing the save button bar (accessory part).....	85
4-2. Model classification according to the button size.....	85
4-3. Attaching the shank button (optional).....	86
III. DRAWING OF THE TABLE.....	90

I. EXPLANATION OF THE LK-1900S, COMPUTER-CONTROLLED HIGH-SPEED BARTACKING MACHINE

1. SPECIFICATIONS

1	Sewing area	X (lateral) direction 40 mm Y (longitudinal) direction 30 mm
2	Sewing speed	Regular sewing speed : 2,700 sti/min* (When sewing pitches are less than 5.5 mm in X-direction and 4.0 mm in Y -direction.) Max. sewing speed : 3,200 sti/min* (When sewing pitches are less than 5.0 mm in X-direction and 3.5 mm in Y -direction.)
3	Stitch length	0.1 to 10.0 mm (adjustable in 0.1 mm step)
4	Feed motion of work clamp foot	Intermittent feed (2-shaft drive by stepping motor)
5	Needle bar stroke	41.2 mm
6	Needle	DP × 5, DP × 17
7	Lift of work clamp foot	13 mm (standard) Max. 17 mm
8	Shuttle	Standard semi-rotary hook (oil wick lubrication)
9	Lubricating oil	New Defrix Oil No. 2 (supplied by oiler)
10	Data recording	Memory in MAIN PCB (80 Kbite)
11	Enlarging / Reducing facility	20% to 200% (1% step) in X direction and Y direction respectively
12	Enlarging / Reducing method	Pattern enlargement / reduction can be done by increasing/decreasing the stitch length
13	Max. sewing speed limitation	400 to 2,700 sti/min* (100 sti/min steps)
14	Pattern selection	Standard patterns: 51 User patterns: 1 to 200 Media patterns: 1 to 999
15	Bobbin thread counter	UP/DOWN type (0 to 9999)
16	Sewing machine motor	Servo motor
17	Dimensions	W : 1,200 mm L : 660 mm H : 1,100 mm (Use the standard table and stand.)
18	Mass	Machine head 42 kg, Control box 5.1 kg
19	Power consumption	250 VA (Pattern No. 1, 2,700 sti/min, 2-sec pause time)
20	Operating temperature range	5 °C to 35 °C
21	Operating humidity range	35% to 85% (No dew condensation)
22	Line voltage	AC220 to 240V ± 10% 50/60 HZ
23	Noise	- Equivalent continuous emission sound pressure level (L _{pA}) at the workstation : A-weighted value of 82 dB; (Includes K _{pA} = 2.5 dB); according to ISO 10821-C.6.3 -ISO 11204 GR2 at 2,700 sti/min for the sewing cycle, 1.0s ON (Pattern : No.1). - Sound power level (L _{WA}) ; A-weighted value of 89 dB; (Includes K _{WA} = 2.5 dB); according to ISO 10821-C.6.3 -ISO 3744 GR2 at 2,700 sti/min for the sewing cycle, 1.0s ON (Pattern : No.1).

* Reduce the max. sewing speed in accordance with the sewing conditions.

2. CONFIGURATION

2-1. Names of main unit

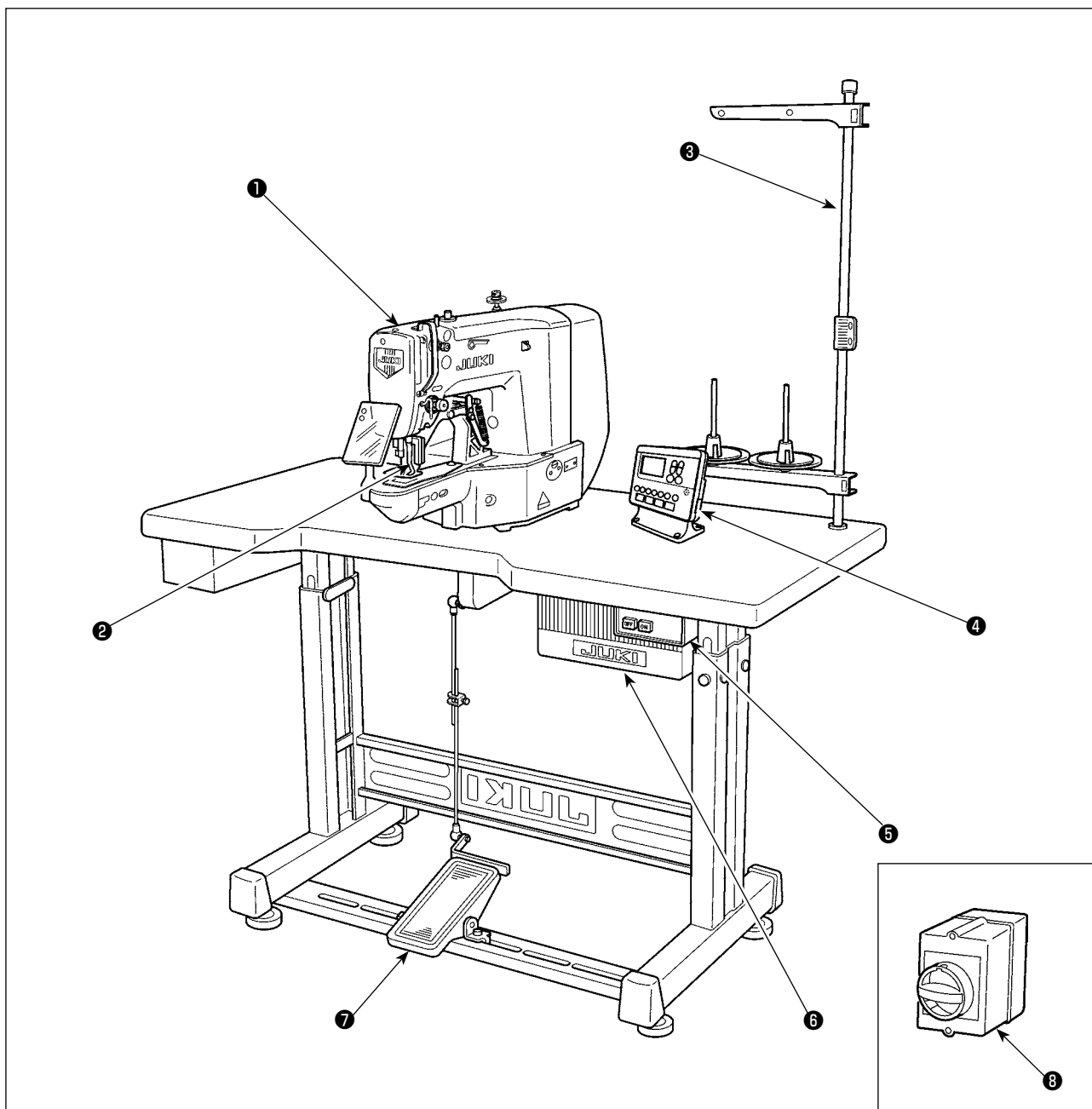

- ① Machine head
- ② Work clamp feet
- ③ Thread stand
- ④ Operation panel
- ⑤ Power switch
- ⑥ Control box
- ⑦ Pedal
- ⑧ Power switch (EU type)

2-2. Names and explanation of switches on the operation panel

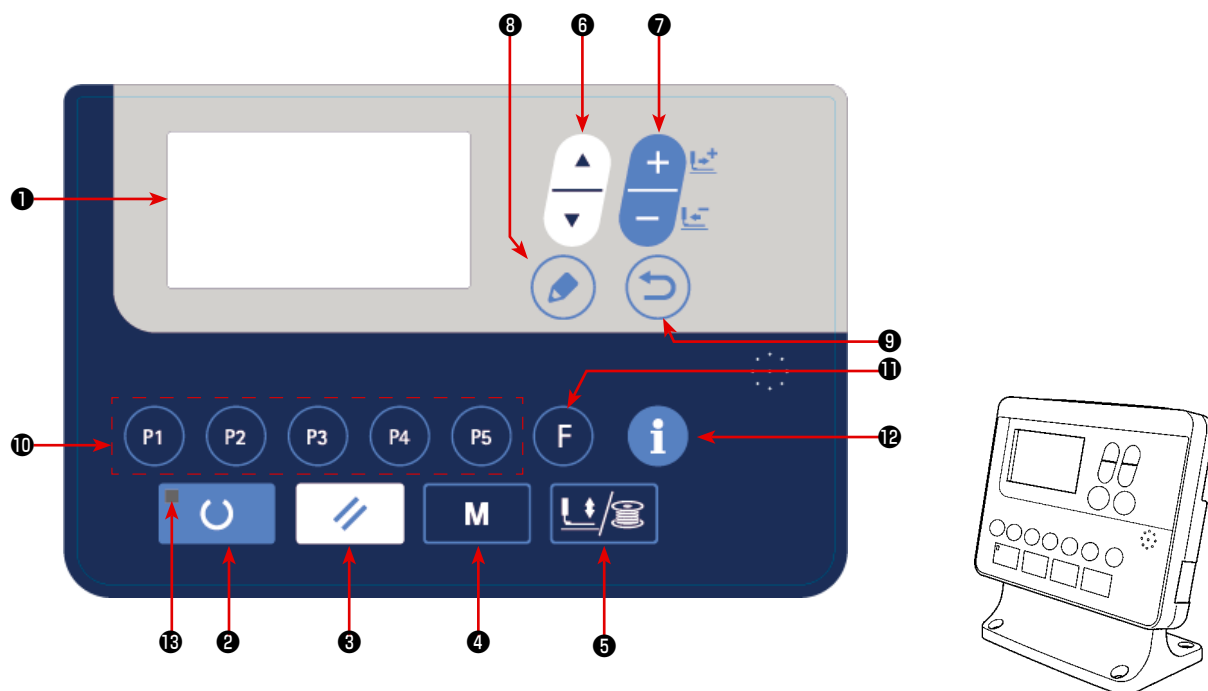

No.	NAME	FUNCTION
①	LCD display	Various data such as pattern No., shape, etc. are displayed.
②	READY key 	Press this key when starting sewing. Every time this key is pressed, change-over of sewing ready set state and data set state can be performed.
③	RESET key 	Press this key when releasing error, traveling the feed mechanism to its initial position, counter resetting, etc.
④	MODE key 	This key is used for displaying the mode screen.
⑤	PRESSER and WINDER key 	This key lifts or lowers the presser. When the presser goes up, the needle bar travels to the origin and when it comes down, the needle bar travels to the right. This key is pressed when performing bobbin winding.
⑥	ITEM SELECT key 	This key is used to select the data No. and other kinds of data.
⑦	DATA CHANGE key 	This key is used to change the pattern No. and other kinds of data. This key is used to move the feed forward on a stitch-by-stitch basis.

No.	NAME	FUNCTION
⑧	EDIT key 	This key is used to display the edit screen, to select the item or to display the detail screen.
⑨	RETURN key 	This key is used to return the screen to the previous one.
⑩	DIRECT PATTERN 	This key registers the pattern. When this key is pressed, the pattern registered here can sew immediately. X/Y scale, sewing position, etc. can be changed and registered.
⑪	FUNCTION key (F key) 	This is the shortcut key to which a parameter can be registered.
⑫	INFORMATION key 	This key used to carryout setting and checking of the production counter and the production support function.
⑬	SET READY LED	The LED lights up under the sewing mode.

3. INSTALLATION

3-1. Installing the electrical box

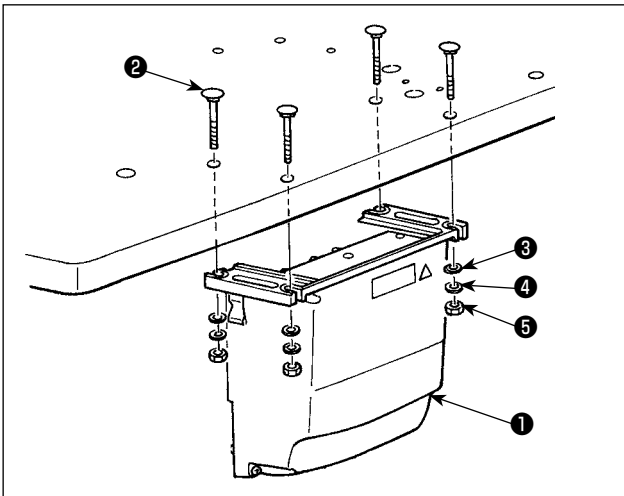

Install control box **1** to the location illustrated in the figure using four bolts **2**, four plain washers **3** and four spring washers **4** and four hexagonal nuts **5** supplied with the unit.



Bolt **2** is a cup head square neck bolt (M8; Length: 70 mm) and nut **5** is a hexagonal nut (M8).

3-2. Installing the pedal sensor

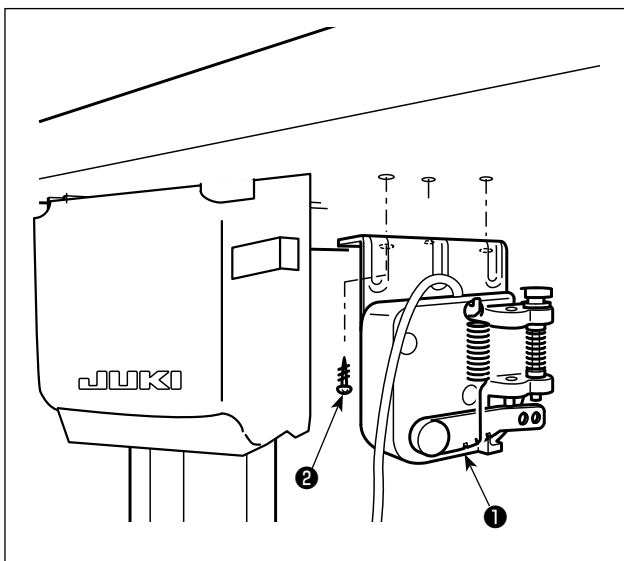

Install the pedal sensor **1** to the table with mounting screws **2** supplied with the unit.

3-3. Attaching the connecting rod

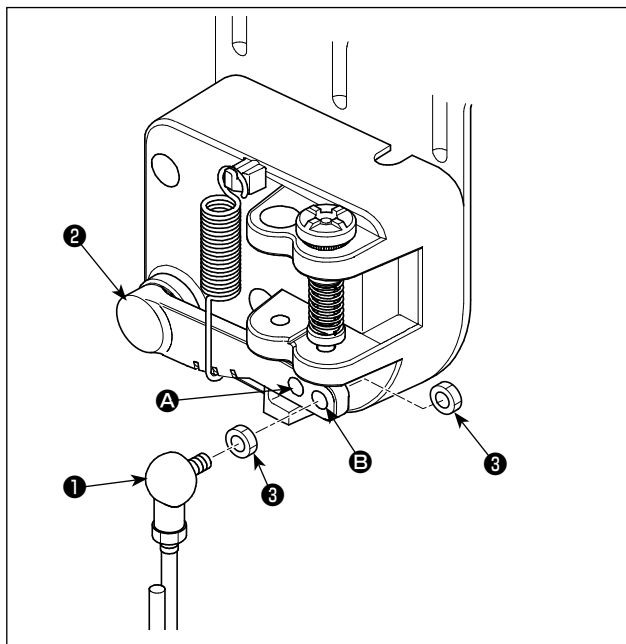

- 1) Fix connecting rod ① to installing hole ② of pedal lever ② with nut ③ .
- 2) The pedal depressing stroke is decreased by fitting connecting rod ① in mounting hole ①.

3-4. Installing the head support rod

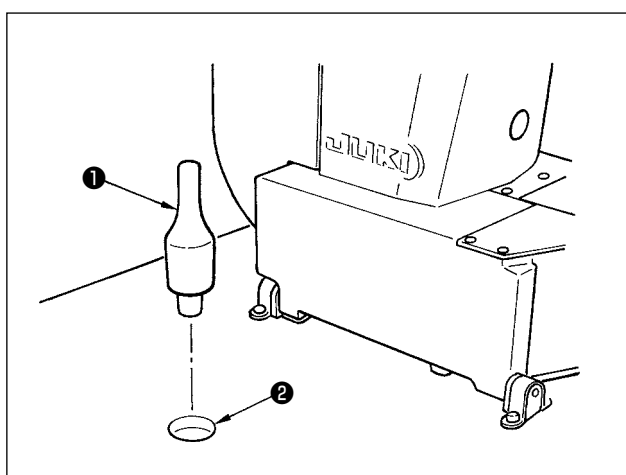

Drive head support rod ① in hole ② in the machine table.

3-5. Installing and connecting the power switch

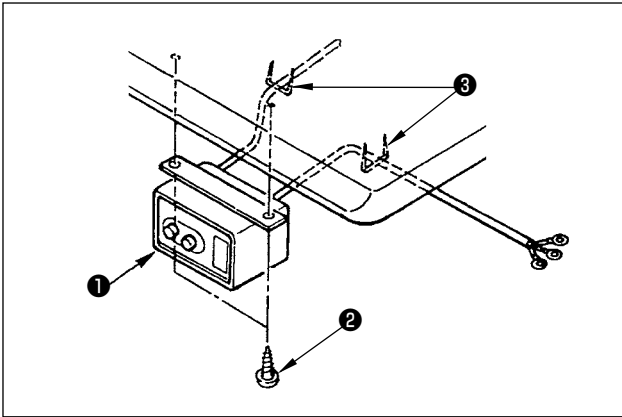

(1) Installing the power switch

Fix power switch ① under the machine table with wood screws ② .

Fix the cable with staples ③ supplied with the machine as accessories in accordance with the forms of use.

(2) Connecting the power source cord

Voltage specifications at the time of delivery from the factory are indicated on the voltage indication seal. Connect the cord in accordance with the specifications.

Power indication tag

Caution Never use under the wrong voltage and phase.

Rating plate

• Connecting single phase 220V, 230V and 240V

3-6. How to carry the sewing machine

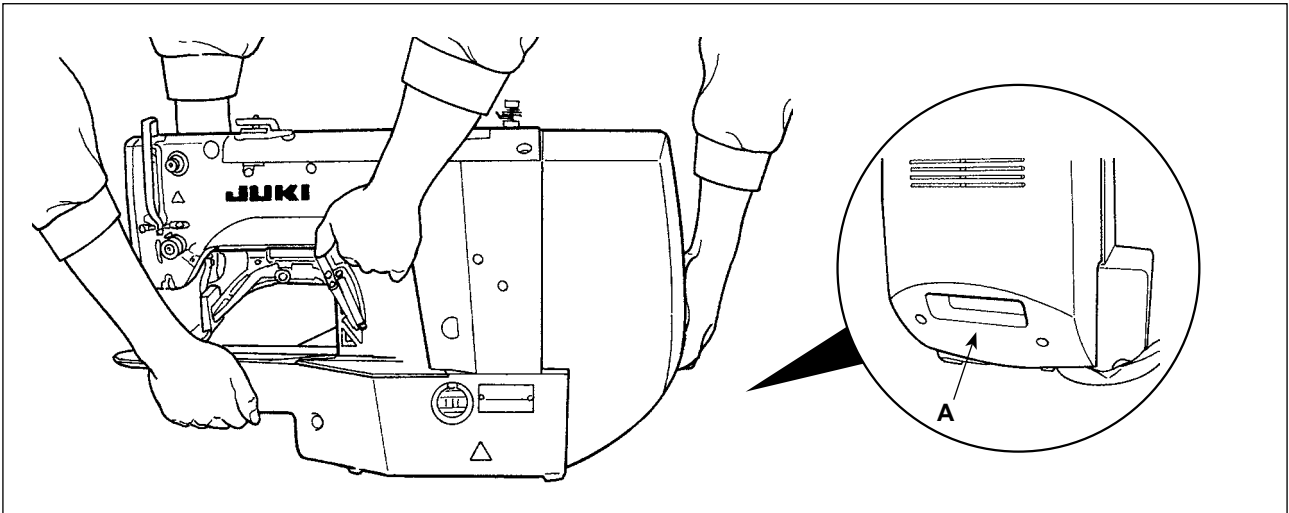

To carry the sewing machine, it is necessary to hold **A** section and support the side faces of the sewing machine by hand as illustrated in the figure.



1. Carefully prevent slippage of your hand that holds the cover.
2. The sewing machine weighs over 42 kg. Be sure to carry the sewing machine with two or more people without exceptions.
3. The LED light is installed to the undersurface of the frame. Do not hold the LED light when moving the frame.

3-7. Installation of the sewing machine head



WARNING :

To prevent possible accidents caused by the full of the sewing machine, perform the work by two persons or more when the machine is moved.

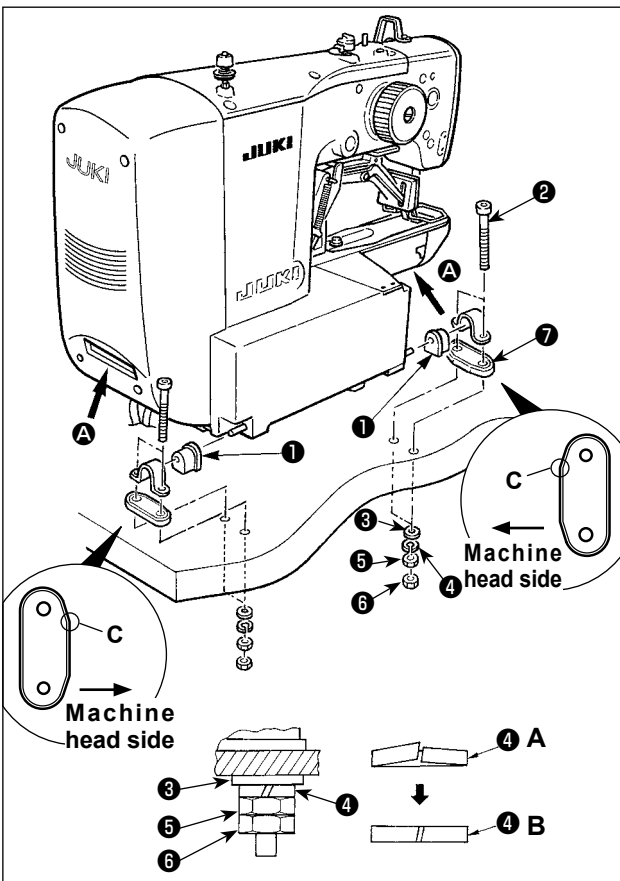

- 1) Fit hinge rubber cushion ① over the hinge shaft.
- 2) Install the main body of the sewing machine on the table with four bolts ②, four plain washers ③, four spring washers ④, four hexagonal nuts ⑤ and four hexagonal nuts ⑥.



1. Tighten nut ⑤ until spring washer ④ is brought to the state as illustrated in Fig. B and fix the spring washer on hinge rubber ⑦ with nut ⑥.
2. Mount hinge rubber ⑦ while orienting its corner section C toward the machine head side. Be aware that the hinge rubber fails to function properly if nuts ⑤ and ⑥ are excessively tightened.
3. When carrying the sewing machine, hold sections A with hands to support the side faces of the sewing machine.

3-8. Installing the drain receiver and the head support rubber

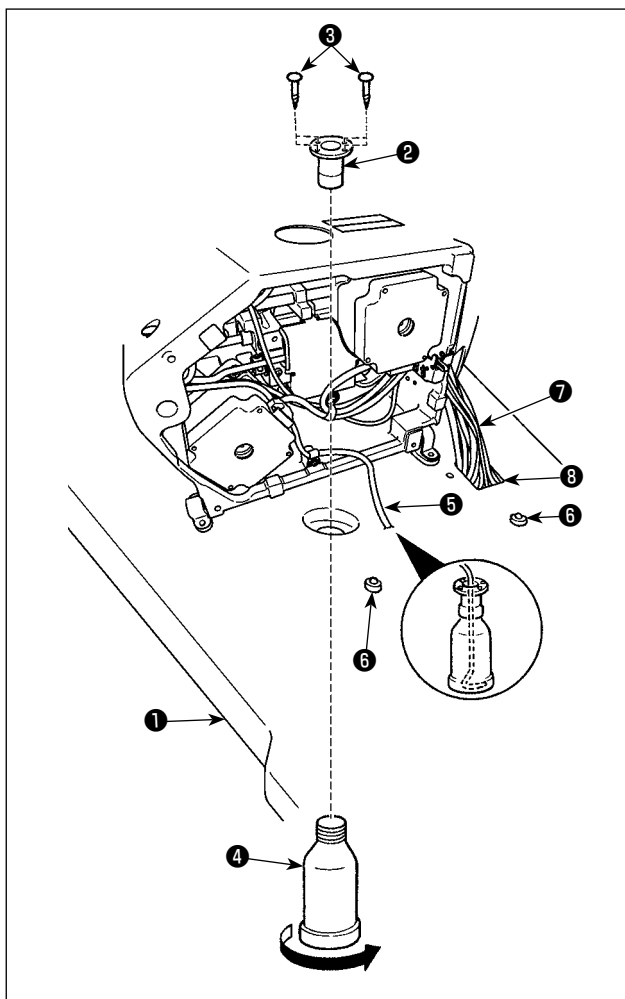

- 1) Fix drain receiver ② in the installing hole of table ① with two setscrews ③ .
- 2) Screw poly-oiler ④ in waste oil reservoir ② .
- 3) Insert sewing-machine waste oil pipe ⑤ into poly-oiler ④ .
- 4) Insert head support rubber ⑥ into table ① .
- 5) Pass bundle ⑦ of cords through slotted hole ⑧ in the table.



1. Insert drain pipe ⑤ until it will go no further so that it does not come off drain bin ④ when tilting the machine head.
2. Remove the tape fixing drain pipe ⑤ .

3-9. Safety switch



DANGER:

When using the safety switch without removing tape ① , it is very dangerous since the sewing machine works even in the state that it is tilted.

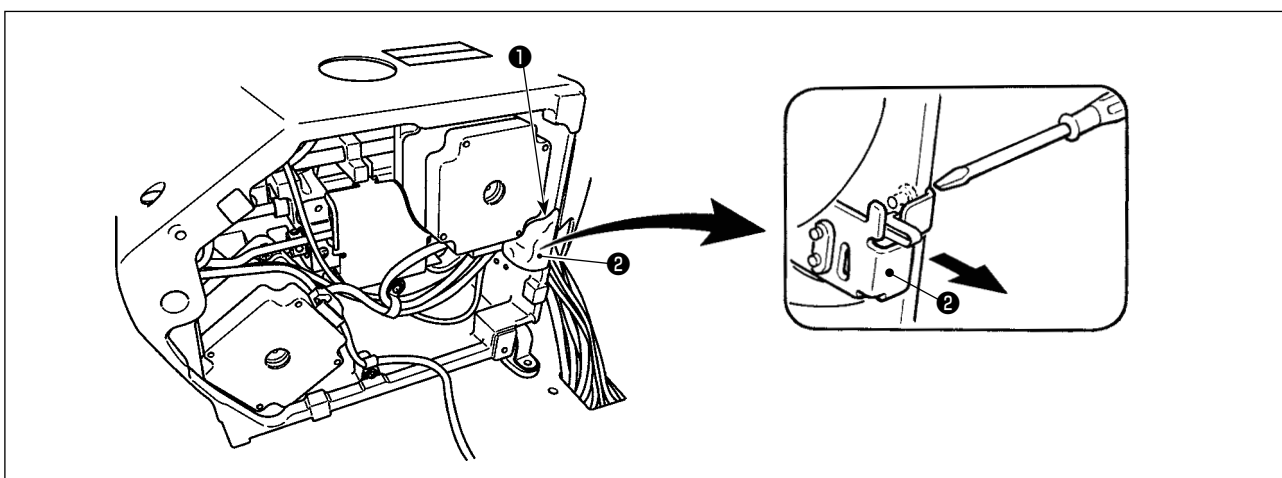

Remove tape ① fixing the lever section of safety switch ② .



In case error 302 occurs when the sewing machine works after setup, loosen the safety switch ② fitting screw with a screwdriver, and lower the switch to the downside of the sewing machine.

3-10. Tilting the sewing machine head



WARNING :

Tilt/raise the sewing machine head with both hands taking care not to allow your fingers to be caught in the head. Turn OFF the power before starting the work so as to prevent accidents caused by abrupt start of the sewing machine.

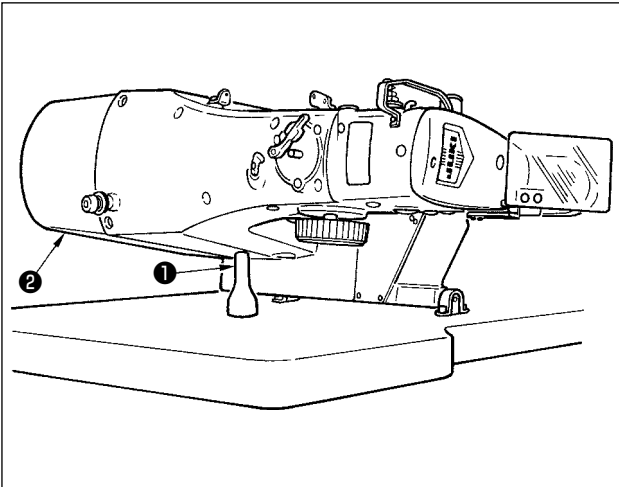

When tilting the sewing machine head, tilt the head gently until it comes in contact with head support rod ① .

① .

1. Before tilting the sewing machine head, make sure that head support rod ① is attached to the machine table.
2. When raising the sewing machine head, do not raise it while holding motor cover ② . It will be the cause of breakage of motor cover ② .
3. Be sure to tilt the sewing machine head on a flat place to prevent it from falling.



3-11. Installing the operation panel

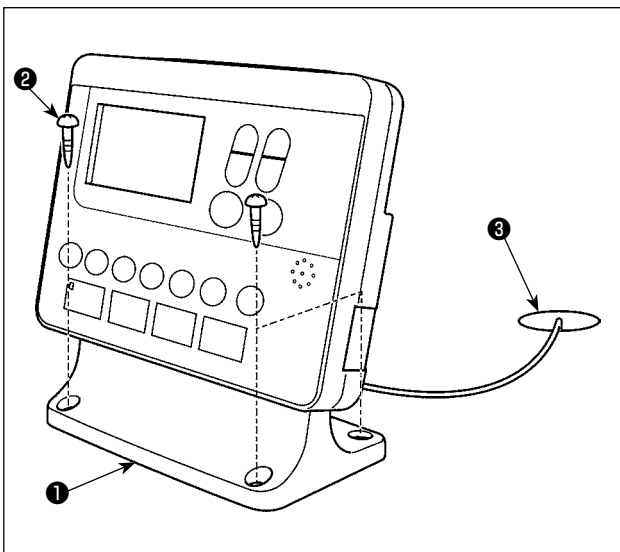

Fix operation panel mounting plate ① on the table with four wood screws ② . Then, pass the cable through hole ③ in the table.

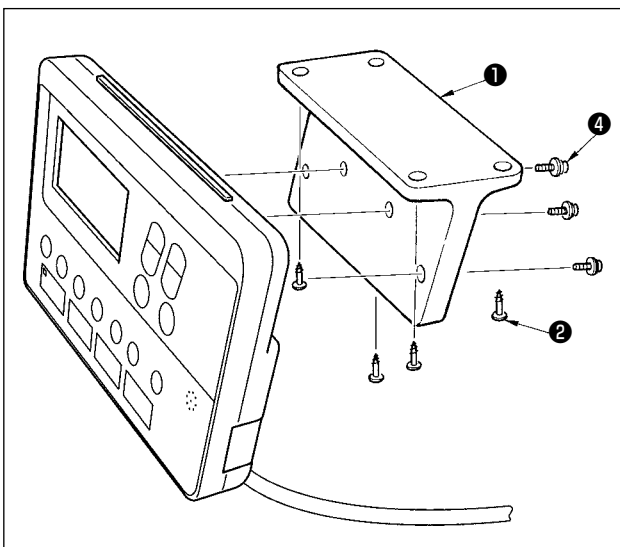

In the case of installing the operation panel on the underside of the table, install the operation panel on panel mounting plate ① by tightening screws ④ in four mounting holes. Then, fix the panel mounting plate at a desired position on the underside of the table with four wood screws ② .

3-12. Connecting the cords



DANGER :

To prevent personal injuries caused by electric shock hazards or abrupt start of the sewing machine, carry out the work after turning OFF the power switch and a lapse of 5 minutes or more. To prevent accidents caused by unaccustomed work or electric shock, request the electric expert or engineer of our dealers when adjusting the electrical components.

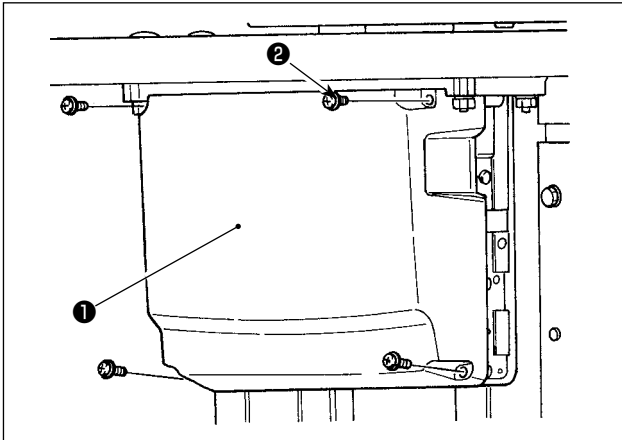

- 1) Loosen four setscrews ② of control box cover ①. Remove control box cover ①.
- 2) Connect the cords to the respective connectors on MAIN PWB, SDC PWB. (Fig. 1)
- 3) Fix the ground wire on position A of the control box with a screw. (Fig. 2)

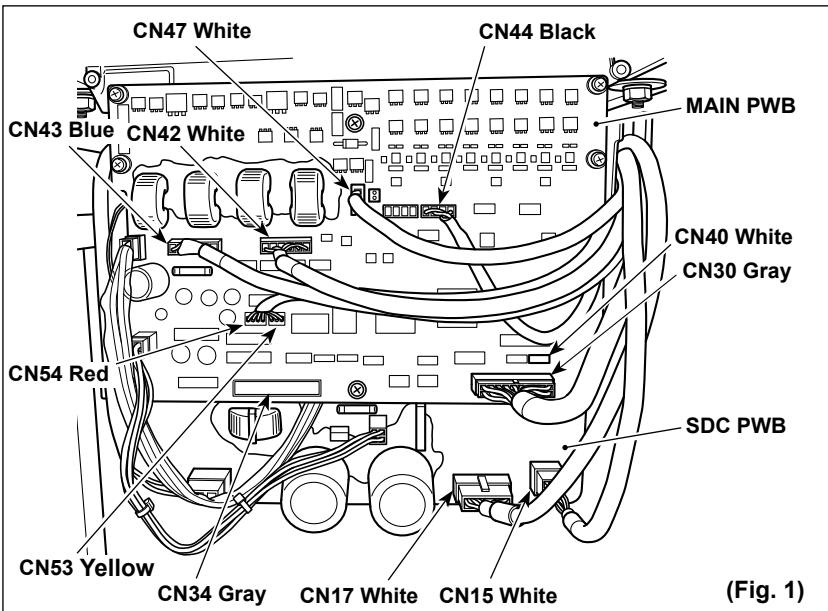
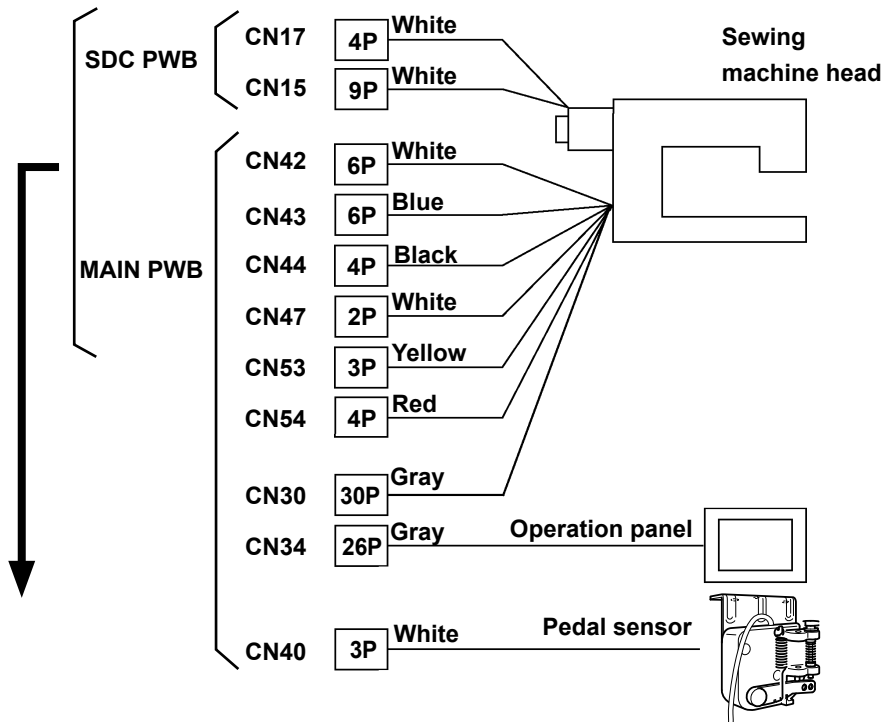

(Fig. 1)

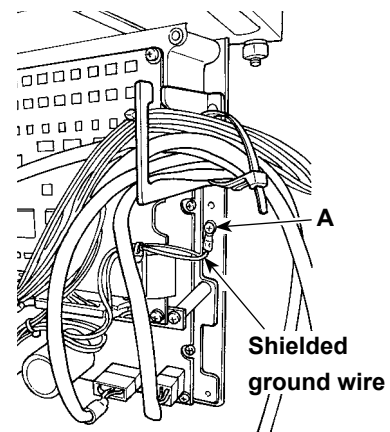

(Fig. 2)

3-13. Handling the cords



DANGER :

To prevent personal injuries caused by electric shock hazards or abrupt start of the sewing machine, carry out the work after turning OFF the power switch and a lapse of 5 minutes or more. To prevent accidents caused by unaccustomed work or electric shock, request the electric expert or engineer of our dealers when adjusting the electrical components.

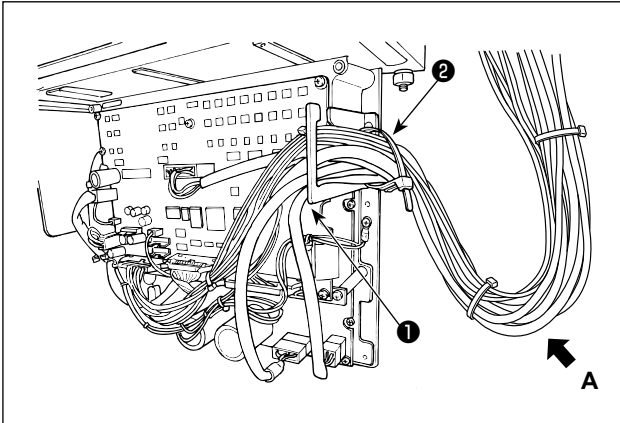

- 1) Bring the cords under the table into the control box.
- 2) Put the cord brought into the control box through cord exit plate ① and fix cable clip band ② .



Arrange the cord so that it is not tensed or hitched even when the machine head is tilted. (See A section)

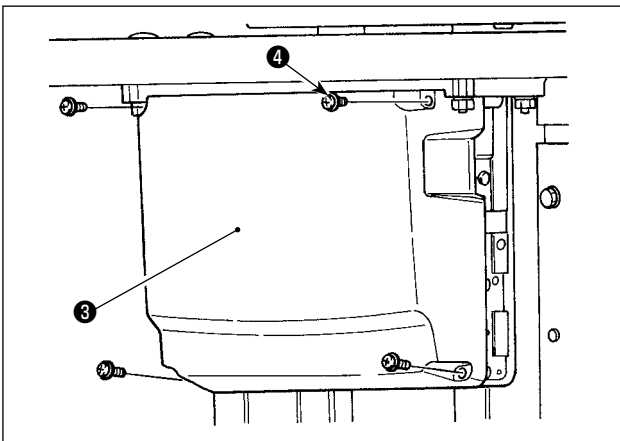

- 3) Install control box lid ③ with four setscrews ④ .

3-14. Installing the eye protection cover



WARNING :

Be sure to attach this cover to protect the eyes from the disperse of needle breakage.

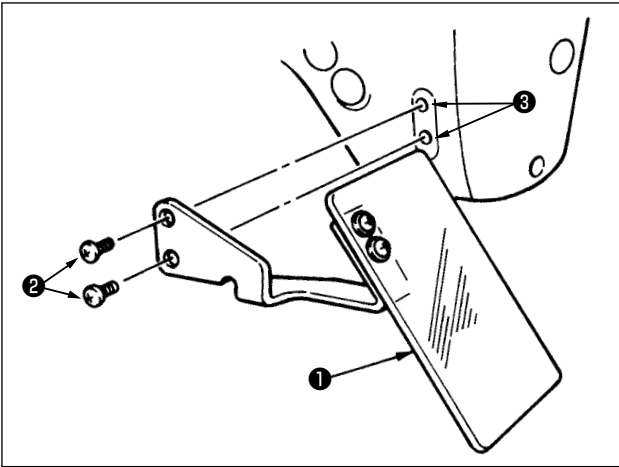

Be sure to use eye protection cover **1** after installing it on installing section **3** with screws **2** .

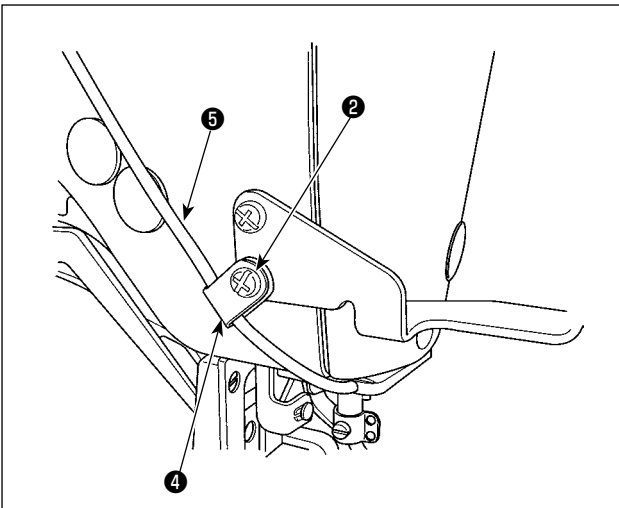

Pass LED cord **5** through accessory cord clamp **4** supplied with the unit as shown in the figure. Fix the LED cord with screw **2** located at the lower section of eye protection cover **1** .

3-15. Installing the thread stand

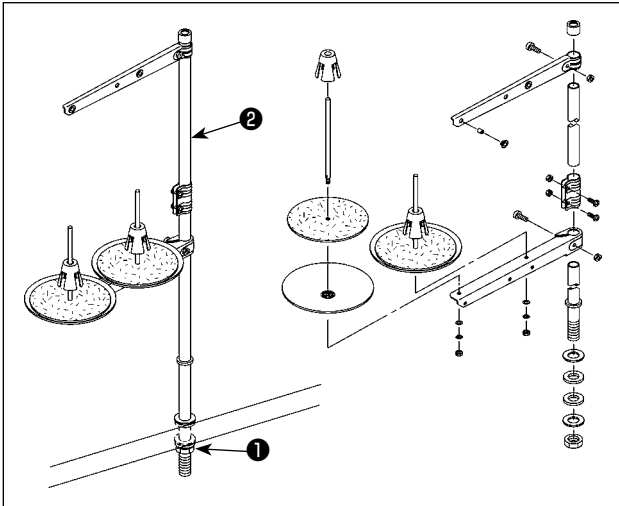

- 1) Assemble the thread stand unit, and insert it in the hole in the machine table.
- 2) Tighten locknut **1** to fix the thread stand.
- 3) For ceiling wiring, pass the power cord through spool rest rod **2**.

3-16. In the case the machine is transported after factory-completed at the time of shipment

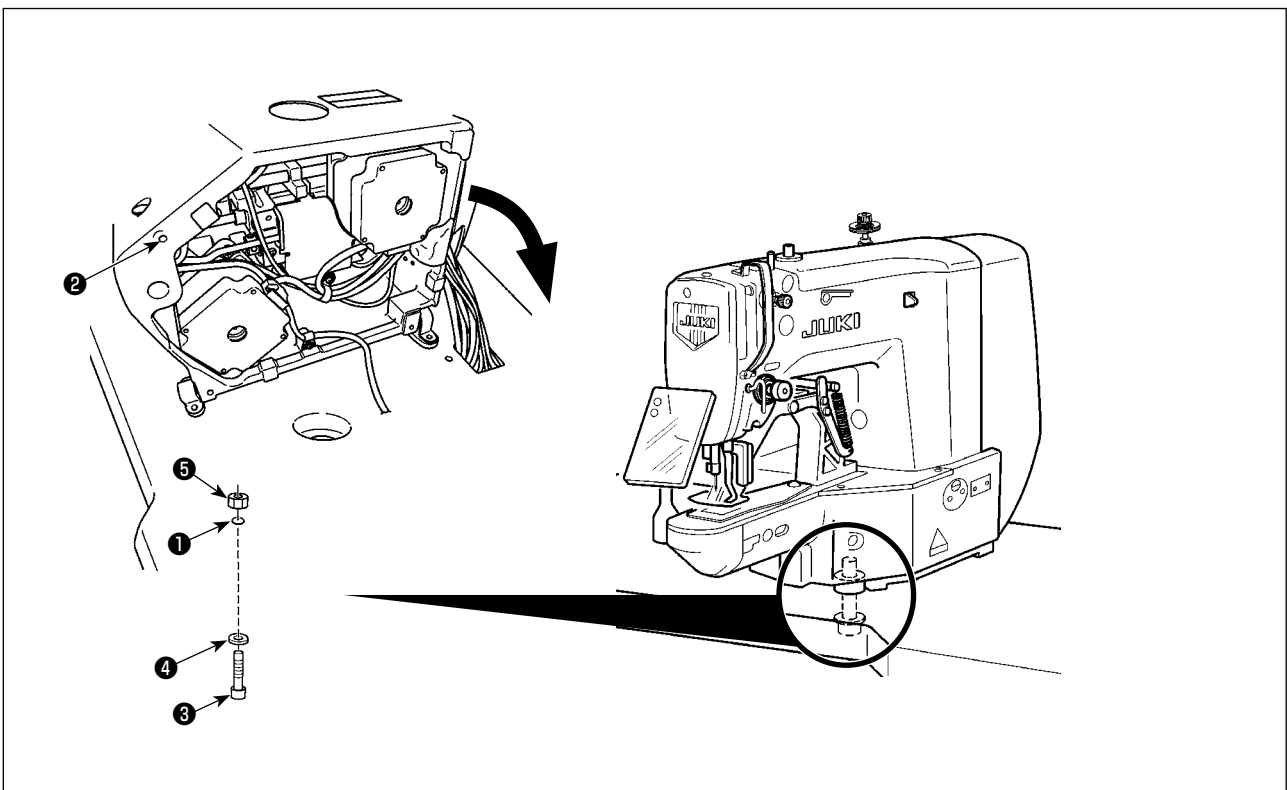

Pass bed fixing bolt **3**, plain washer **4** and nut **5** through hole **1** in the table and hole **2** in the sewing machine bed to fix the bed on the table.

4. OPERATION OF THE SEWING MACHINE

4-1. Lubrication



WARNING :

Turn OFF the power before starting the work so as to prevent accidents caused by abrupt start of the sewing machine.

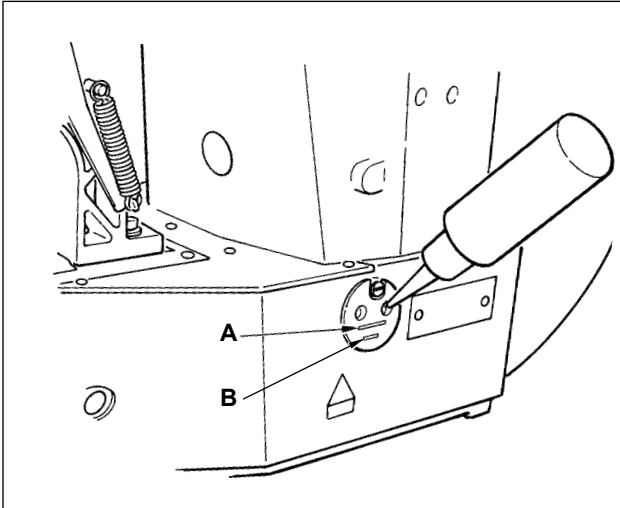

Check that the place between lower line **B** and upper line **A** is filled with oil. Fill there with oil using the oiler supplied with the machine as accessories when oil is short.

* The oil tank which is filled with oil is only for lubricating to the hook portion. It is possible to reduce the oil amount when the number of rotation used is low and the oil amount in the hook portion is excessive. (Refer to "[1.7-7. Amount of oil supplied to the hook](#)" p.55.)

1. Do not lubricate to the places other than the oil tank and the hook of Caution 2 below. Trouble of components will be caused.



2. When using the sewing machine for the first time or after an extended period of disuse, use the machine after lubricating a small amount of oil to the hook portion. (Refer to "[1.7-2. Adjusting the needle-to-shuttle relation](#)" p.52.)

4-2. Attaching the needle



WARNING :

Turn OFF the power before starting the work so as to prevent accidents caused by abrupt start of the sewing machine.

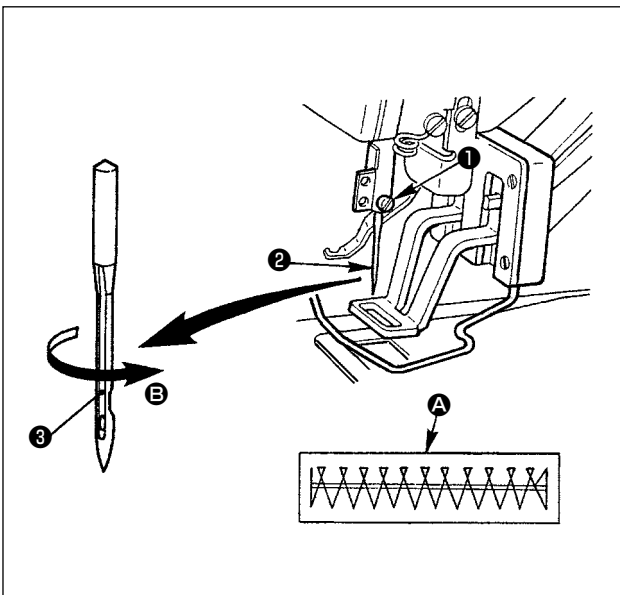

Loosen setscrew ❶ and hold needle ❷ with the long groove ❸ facing toward you. Then fully insert it into the hole in the needle bar, and tighten setscrew ❶.



If the stitches are made as shown in **A**, attach the needle facing to the direction **B** to a small extent.

4-3. Threading the machine head



WARNING :

Turn OFF the power before starting the work so as to prevent accidents caused by abrupt start of the sewing machine.

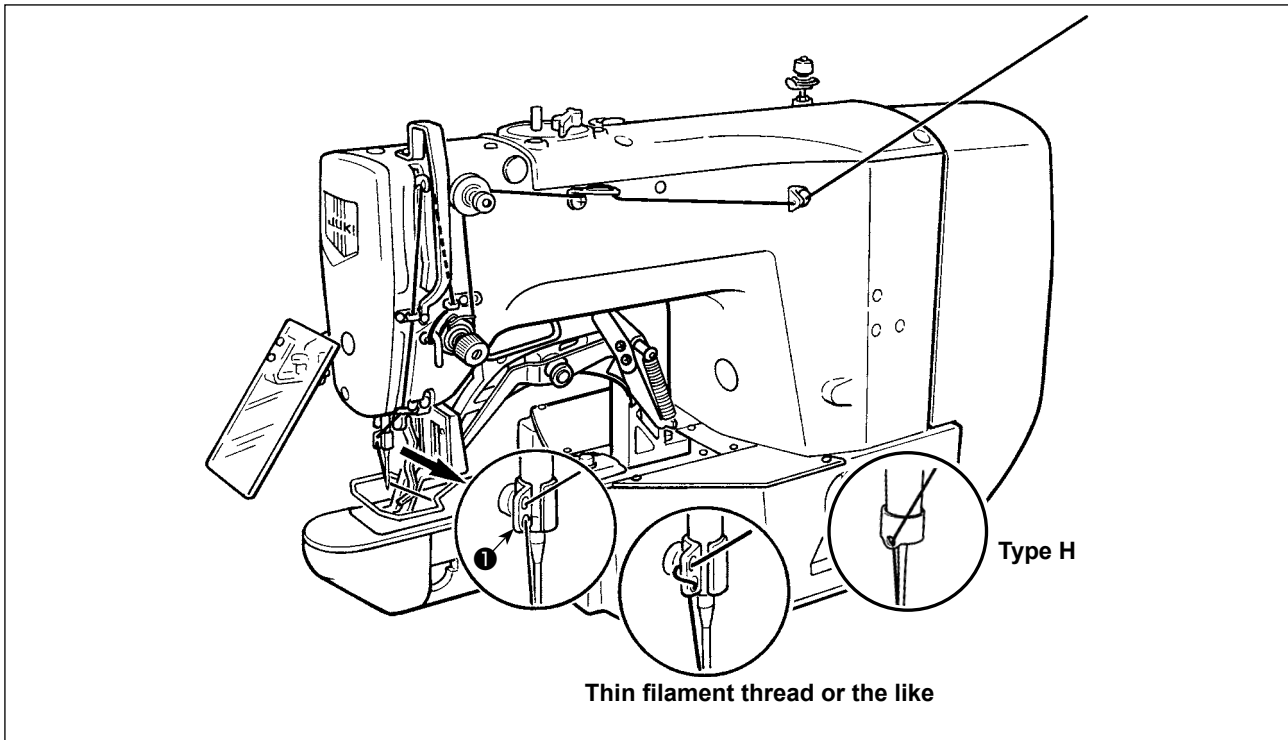

Pull out the thread by approximately 40 mm from the needle after threading through the needle.
If it is difficult to thread the machine head, refer to "[I.5-8. How to open the tension disk](#)" p.24.



For thick thread, pass the thread through one hole only of needle bar thread guide ①.

4-4. Installing and removing the bobbin case



WARNING :

Turn OFF the power before starting the work so as to prevent accidents caused by abrupt start of the sewing machine.

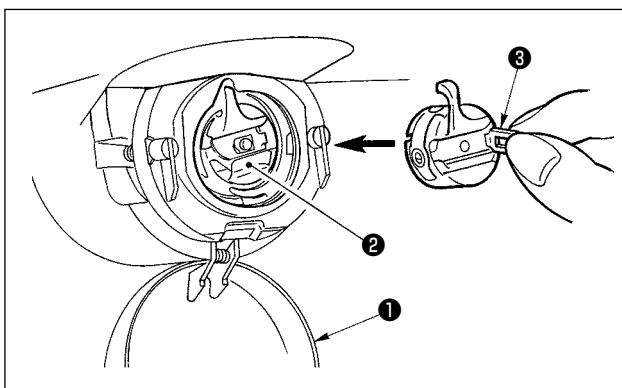

- 1) Open hook cover ①.
- 2) Raise latch ③ of bobbin case ②, and remove the bobbin case.
- 3) When installing the bobbin case, fully insert it into the shuttle shaft, and close the latch.



If it is not fully inserted, bobbin case ② may slip off during sewing.

4-5. Installing the bobbin



WARNING :

Turn OFF the power before starting the work so as to prevent accidents caused by abrupt start of the sewing machine.

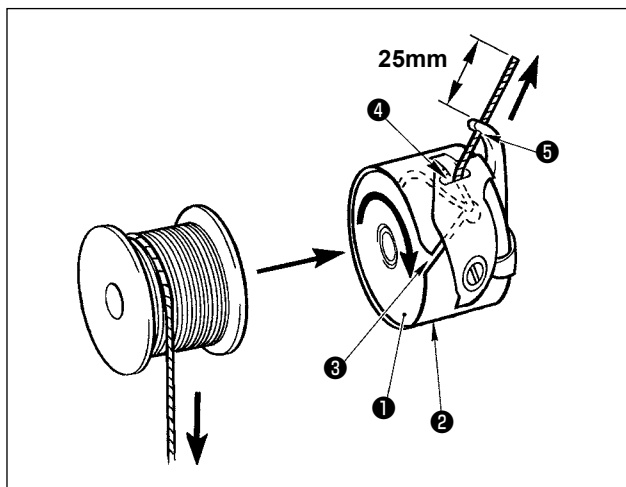

- 1) Set the bobbin ① into bobbin case ② in the direction shown in the figure.
- 2) Pass the thread through thread slit ③ of bobbin case ②, and pull the thread as it is. By so doing, the thread will pass under the tension spring and be pulled out from thread hole ④.
- 3) Pass the thread through thread hole ⑤ of the horn section, and pull out the thread by 25mm from the thread hole.



If the bobbin is installed in the bobbin case orienting the reverse direction, the bobbin thread pulling out will result in an inconsistent state.

4-6. Adjusting the thread tension

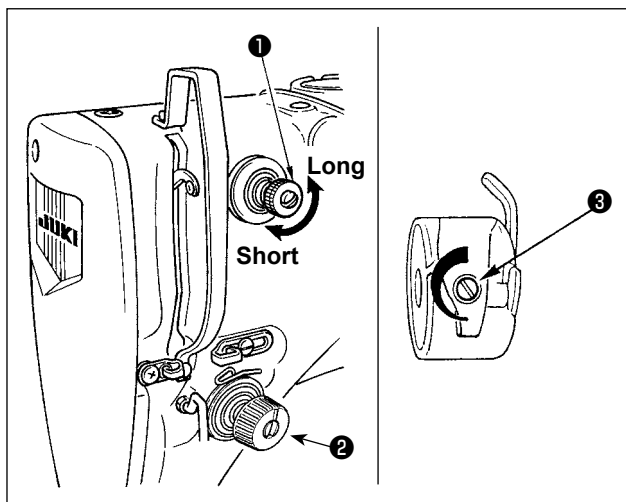

If thread tension controller No. 1 ① is turned clockwise, the length of remaining thread on the needle after thread trimming will be shorter. If it is turned counterclockwise, the length will be longer. Shorten the length to an extent that the thread is not slipped off.

Adjust the needle thread tension with ②. Adjust the bobbin thread tension with ③.

4-7. Adjusting the thread take-up spring

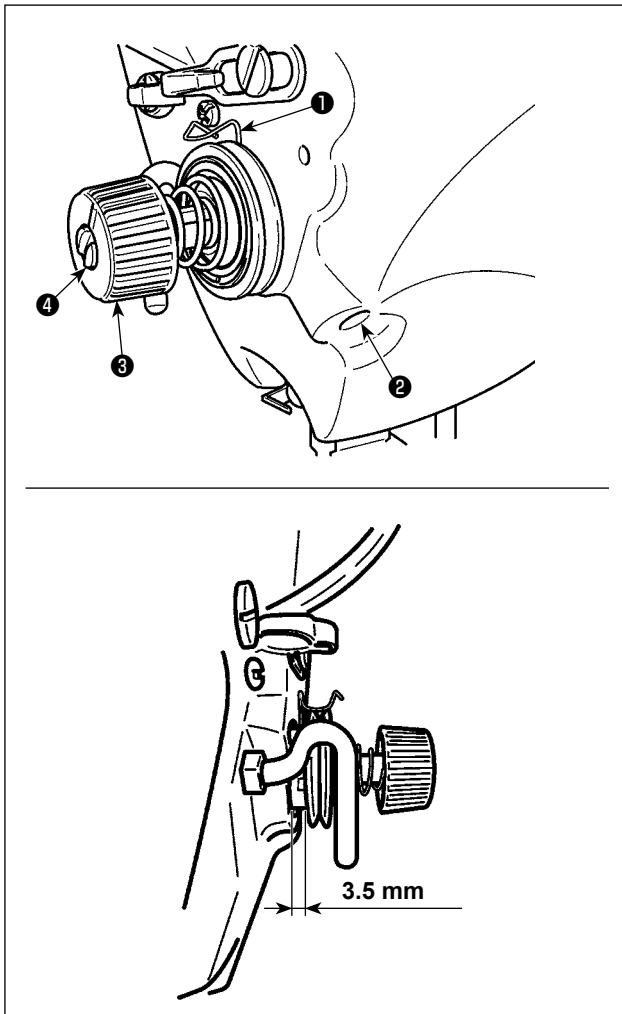

The standard stroke of thread take-up spring ① is 8 to 10 mm, and the pressure at the start is 0.1 to 0.3N.

1) Adjusting the stroke

Loosen setscrew ②, and turn thread tension asm. ③.

Turning it clockwise will increase the moving amount and the thread drawing amount will increase.

2) Adjusting the pressure

To change the pressure of the thread take-up spring, insert a thin screwdriver into the slot of thread tension post ④ while screw ② is tightened, and turn it. Turning it clockwise will increase the pressure of the thread take-up spring. Turning it counterclockwise will decrease the pressure.

In the case you have adjusted the amount of travel of the thread take-up spring ①, check the dish of the thread tension coupled body is closed. It may cause sewing defects.



5. OPERATION OF THE SEWING MACHINE (BASIC)

Set each item following the procedure described below.

5-1. Selection of language

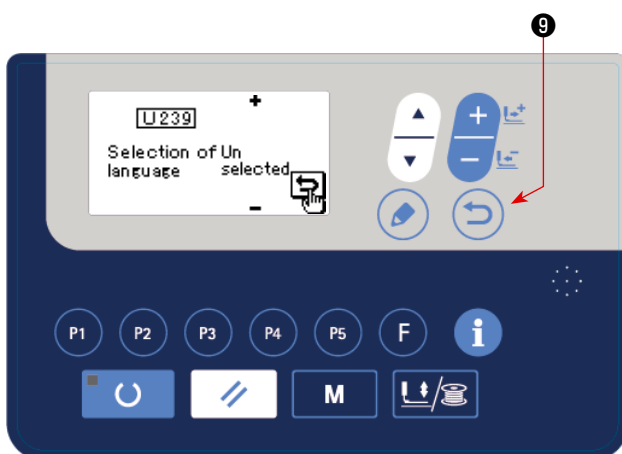

When you turn ON the power to the sewing machine for the first time after the purchase, the language selection screen is displayed. Select the language to

be displayed, then press RETURN key  ⑨.

The language to be displayed on the screen can be changed by means of the memory switch U239 "Language selection". Refer to **"I.8. HOW TO USE THE MEMORY SWITCH"** p.59 for the details of the memory switch.

If you terminate the language selection by pressing RETURN key  ⑨ without selecting the language, the language selection screen will be displayed every time you turn ON the power to the sewing machine.



5-2. Setting the pattern number

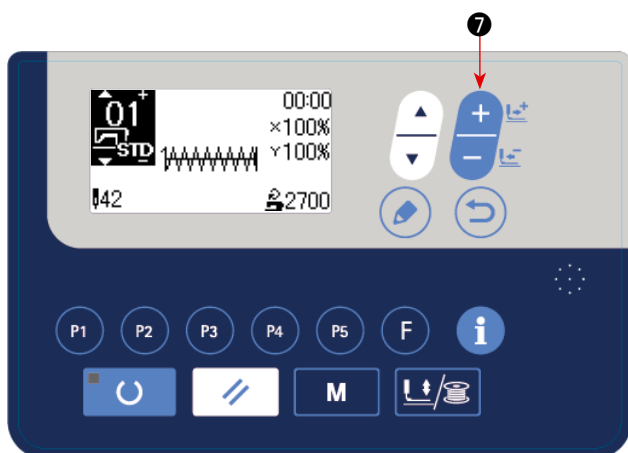

Turn ON the power switch.

The pattern number is displayed at the upper left portion of the screen. The pattern shape, X/Y scale rate and sewing speed of the pattern are also displayed.

When you press DATA CHANGE key  7, the pattern number can be changed.

Caution Refer the pattern No. to the separate table.

5-3. Setting the item data

When you press EDIT key  8, the item data input screen is displayed.

The items that can be edited are displayed on the left section of the screen and the set contents are displayed on the right section of the screen.

Select an item with ITEM SELECT key  6. Then, change the set content with DATA CHANGE key



(1) Inputting the X size

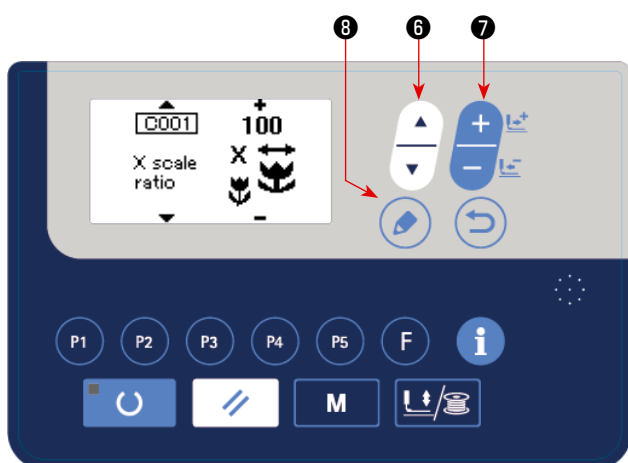

Press ITEM SELECT key  6 to display the C001 X size.

Press DATA CHANGE key  7 to display the value you desire.

One of the input method for the X/Y sizes can be selected; i.e., by inputting a percentage (%) with memory switch U064 or by inputting an actual value. (Initial value: Input in terms of percentage (%))

Caution The setting exceeding 100% is dangerous since needle and the cloth presser interferes with each other and needle breakage or the like will occur.

(2) Inputting the Y size

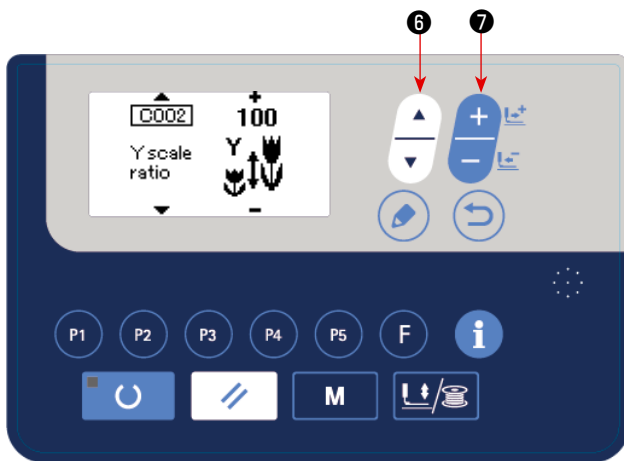

Press ITEM SELECT key  ⑥ to display the C002 Y size.

Press DATA CHANGE key  ⑦ to display the value you desire.

One of the input methods for the X/Y sizes can be selected; i.e., by inputting a percentage (%) with memory switch U064 or by inputting an actual value. (Initial value: Input in terms of percentage (%))

The setting exceeding 100% is dangerous since needle and the cloth presser interferes with each other and needle breakage or the like will occur.

(3) Inputting the sewing speed

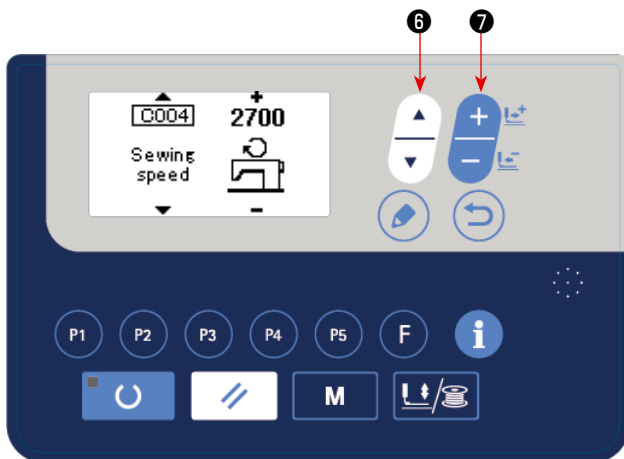



Press ITEM SELECT key  ⑥ to display the C004 sewing speed.

Press DATA CHANGE key  ⑦ to display the value you desire.

The maximum input range is the maximum sewing speed of the memory switch U001.

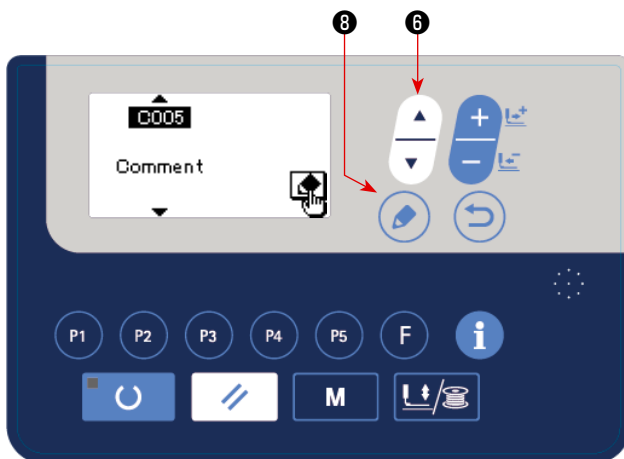
(4) Setting the comment





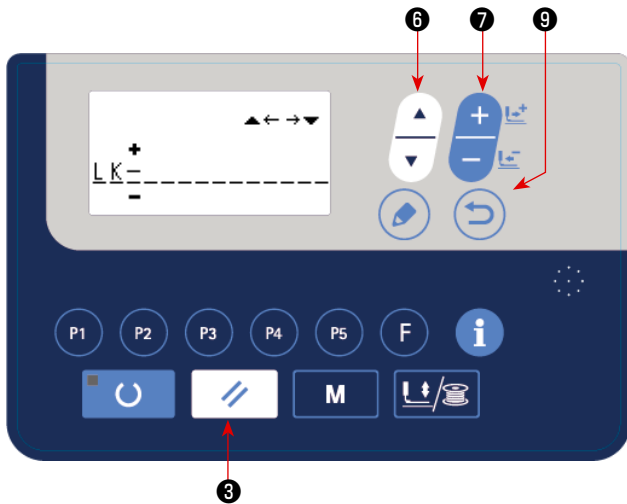

Press ITEM SELECT key  ⑥ to display the C005 comment.

Press EDIT key  ⑧ to display the comment input screen.



On the comment input screen, as many as 14 characters can be input. The characters that can be input are alphabets, numbers and symbols.

Press ITEM SELECT key  ⑥ to specify the input position. Press DATA CHANGE key  ⑦ to select the characters to be entered.

When you press RESET key  ⑧, the character at the current input position is erased. When you keep RESET key  ⑧ held pressed, all characters which have been input are erased.

After the completion of input of a comment, the screen is returned to the previous screen by pressing RETURN key  ⑨.

Caution As many as 14 characters can be entered for the comment. However, only eight characters are displayed under the input mode.

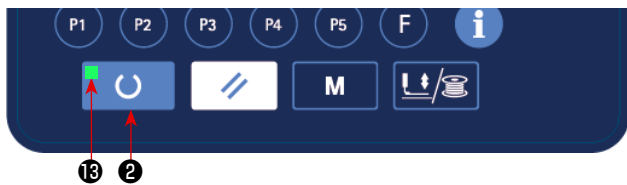

(5) Completing the setting



Press READY key  ②.

The work clamp moves. Then, SET READY LED ⑬ lights up after the work clamp has gone up to enable sewing.

Caution When the presser is raised, be careful that fingers are not caught in the presser since the presser moves after having lowered.

- * When READY key  ② is pressed, the set values of pattern No., X/Y scale, etc. are memorized.
- * When READY key  ② is pressed, SET READY LED ⑬ goes out. Setting of each item can be changed.
- * Check the pattern number before use. If you press READY key  ② with pattern number 0 displayed, error display E010 will be shown on the screen. At this time, re-set the pattern number.

Important In the case the power to the sewing machine is turned OFF without pressing READY key  ②, the pattern number and the set values for the X/Y scale rate and maximum sewing speed will not be saved.



5-4. Checking the contour of a sewing pattern

WARNING :

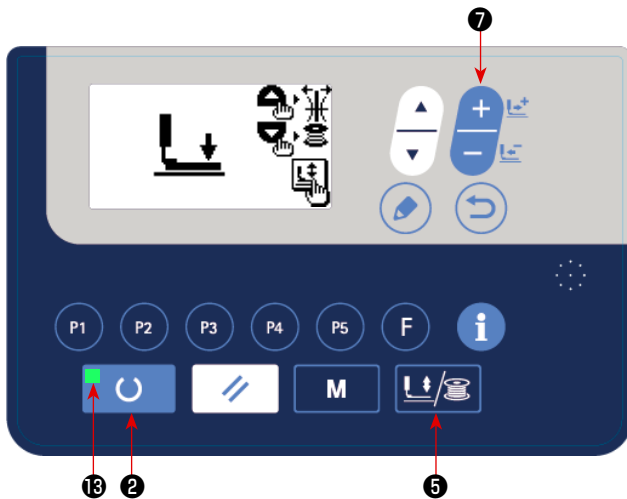

1. Make sure without fail of the contour of the sewing pattern after selection of the sewing pattern. If the sewing pattern extends outside the work clamp feet, the needle will interfere with the work clamp feet during sewing, causing dangerous troubles including needle breakage.
2. When making sure of the contour of the sewing pattern, press + / - key with the needle bar lowered, and the work clamp feet move after automatically making the needle bar return to the upper position.





- 1) Press READY key  (2) to light up the SET READY LED (13).
- 2) Press work PRESSER and WINDER key  (5) to display "work clamp lowering screen".
- 3) Display the shape check screen with + key  (7).

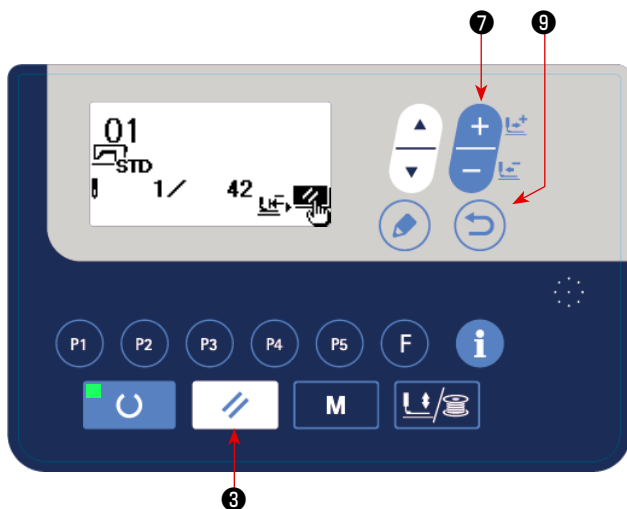

Under this mode, the sewing machine will not start running even if you depress the pedal.



- 4) Check the shape with DATA CHANGE key  (7).
- 5) Press RESET key  (3) to return to the sewing starting position and lift the work clamp. When you press RETURN key  (9), the sewing screen is displayed at the current position. When you depress the pedal in the aforementioned state, the sewing machine starts sewing from the current position.

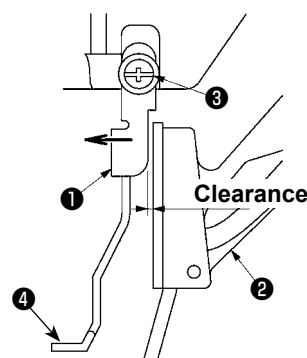
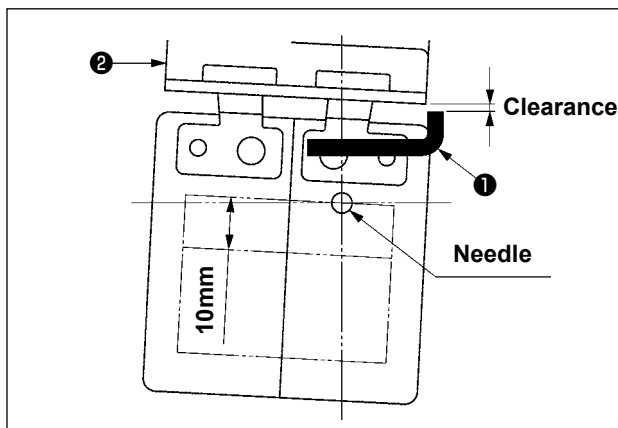

When using a sewing pattern which is full in lengthwise direction (+10 mm), make sure of the clearance between cloth feed base (2) and wiper base (1). If there is no clearance, loosen setscrew (3) and move the wiper (4) to the needle side. Especially when the needle position comes to the rear on the right side, the clearance is decreased.

5-5. Sewing

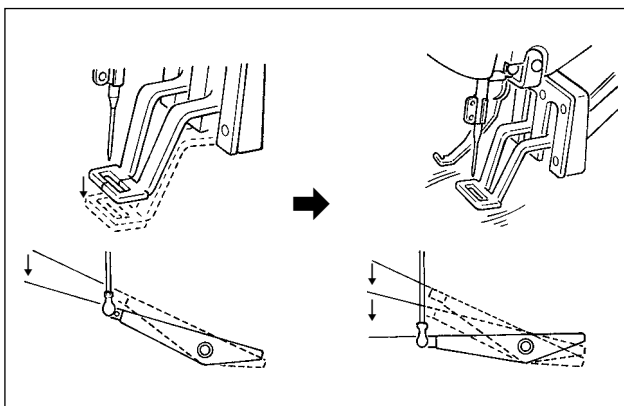

- 1) Set a workpiece on the work clamp foot section.
- 2) When you depress the pedal to the first step, the work clamp comes down. When you release the pedal, the work clamp goes up.
- 3) Depress the pedal switch to the second step after descending the work clamp feet at the first step, and the sewing machine will start sewing.
- 4) After the sewing machine completes sewing, the work clamp feet will go up, and return to the sewing start position.

5-6. Changing the pattern to a different one

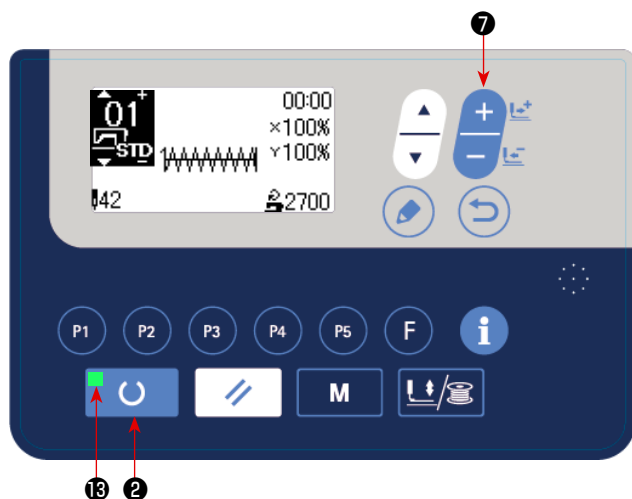

Press READY key  ② to turn off SET READY LED ⑬ .

Set a pattern number with DATA CHANGE key



Set the XY enlargement/reduction scale and speed as with "1.5-4. Checking the contour of a sewing pattern" p.21.

Press READY key  ② to light up SET READY LED ⑬ to enable sewing.



WARNING :

Make sure without fail of the contour of the sewing pattern after selection of the sewing pattern.

If the sewing pattern extends outside the work clamp feet, the needle will interfere with the work clamp feet during sewing, causing dangerous troubles including needle breakage.

5-7. Winding a bobbin

(1) To wind a bobbin while the sewing machine is performing sewing

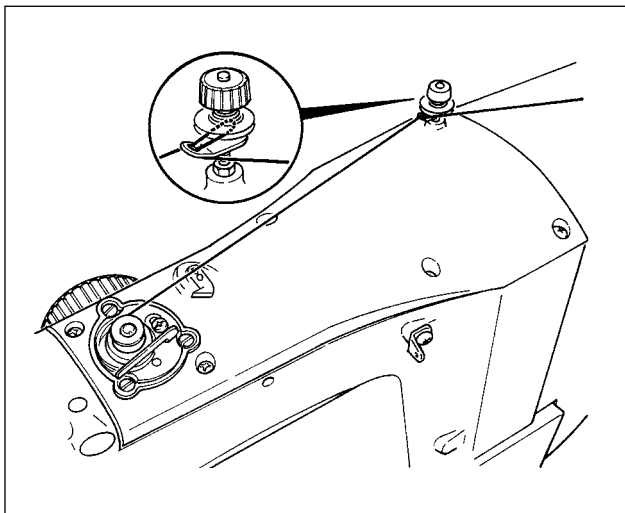

Thread the bobbin winder and wind the bobbin thread onto the bobbin as illustrated in the figure.

(2) For winding a bobbin only

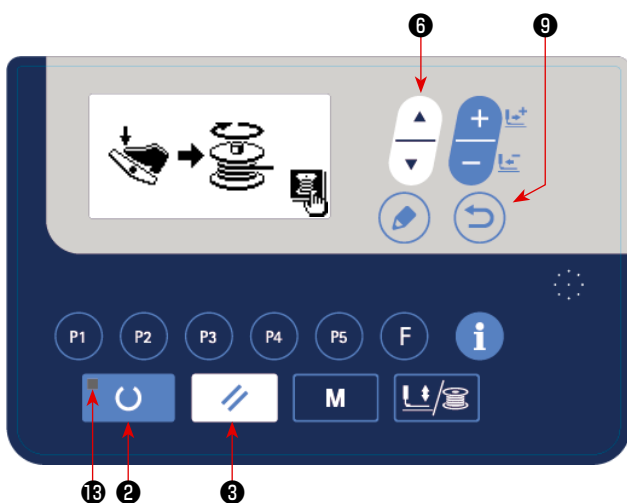
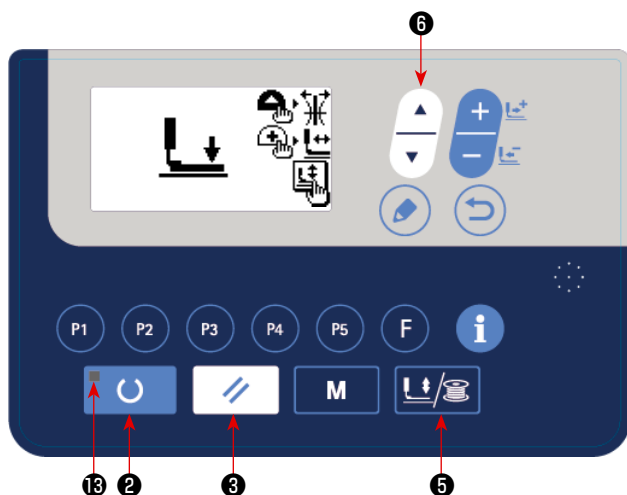

1) Press READY key  ② to turn off SET READY LED ⑬.



2) Press work PRESSER and WINDER key  ⑤ and select lowering of the work clamp.

Caution Selection cannot be performed when the SET READY LED is lit up.

3) Press ▼ key  ⑥. The bobbin winding screen is displayed.

4) When you depress the pedal, the sewing machine starts rotating.

5) Depress the pedal switch again or press RESET key  ③ to stop the sewing machine.

6) Press READY key  ② and RETURN key  ⑨ to exit from the bobbin winding screen.





Caution Bobbin winder does not work immediately after turning ON the power. Perform the bobbin winding after setting pattern No. or the like once, pressing the READY key  ②, and making the SET READY LED ⑬ light up.

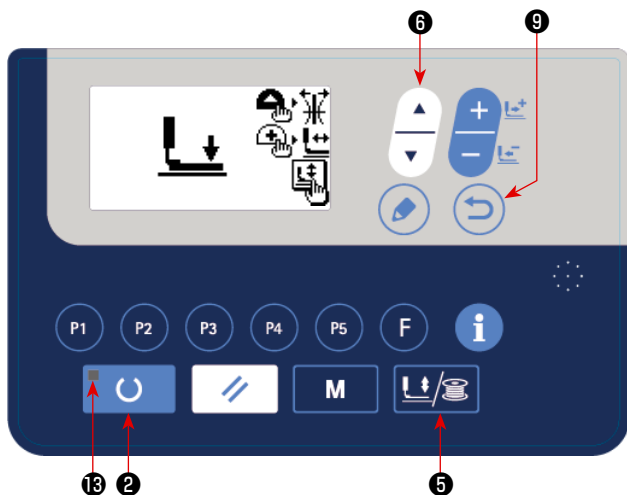

For the LK-1903S, thread the machine after removing the button and the needle.

5-8. How to open the tension disk



- 1) Press READY key  ⑬ to turn off SET READY LED ⑬.
- 2) Press work PRESSER and WINDER key  ⑤ and select lowering of the work clamp.
- 3) Press ▲ key  ⑥. Then, the disk of tension disk opens for 30 seconds.
- 4) The screen is returned to the previous screen by pressing RETURN key  ⑨ and PRESSER and WINDER key  ⑤.

 When the Set Ready LED ⑬ lights up, the same operation can be carried out.



WARNING :

If the disk floating operation is excessively repeated, an error can be caused.

5-9. LED hand light



WARNING :

In order to protect against personal injury due to unexpected start of the sewing machine, never bring hands near the needle entry area or place foot on the pedal during the adjustment of intensity of the LED.

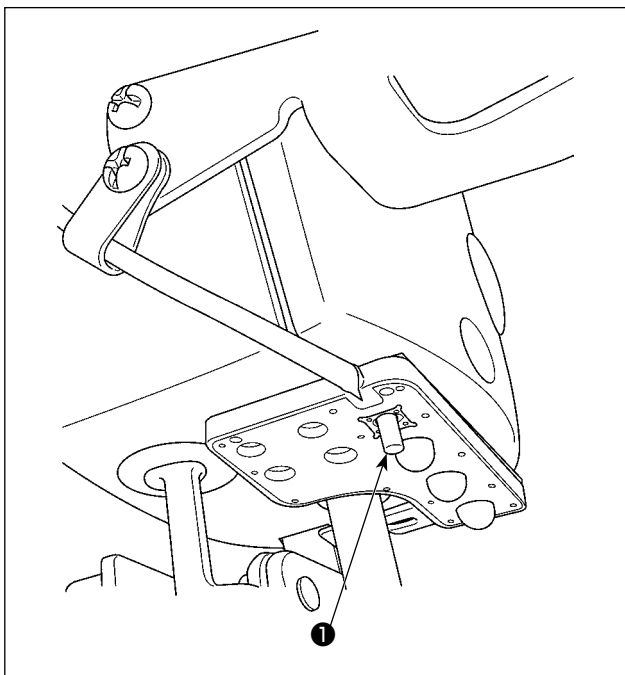

This LED is intended to improve operability of the sewing machine and is not intended for maintenance.



If the LED light is too bright when sewing a narrow sewing material or changing over the sewing material on the sewing machine, the LED light should be dimmed or turned OFF.

The sewing machine is provided as standard with an LED light which illuminates the needle entry area. Intensity adjustment and turn-off of the light is carried out by pressing switch ❶. Every time the switch is pressed, the light is adjusted in intensity in five steps and is turned off in turn.

[Change of intensity]





1 ⇒ 5 ⇒ 6 ⇒ 1
Bright ⇒ Dim ⇒ Off ⇒ Bright

In this way, every time the switch ❶ is pressed, the hand lamp status is changed in repetition.

6. OPERATION OF THE SEWING MACHINE (ADVANCED)

6-1. Performing sewing using the pattern keys

Patterns (No.1 to 200) which have been already registered can be registered to P1 to P50. It is also possible to register the existing direct pattern with its scale, maximum sewing speed limitation and sewing position changed. The direct pattern can be selected by scrolling the pattern number in the same manner as the pattern number (No. 1 to No. 200). In addition, patterns P1 to P25 can be called up with the touch of a button.



* When selecting P6 to P25, perform the selection by combination (simultaneous pressing) of     and  keys as shown in the table below.

P-No.	Selection key	P-No.	Selection key	P-No.	Selection key	P-No.	Selection key
P1	P1	P8	P1+P4	P15	P4+P5	P22	P2+P3+P4
P2	P2	P9	P1+P5	P16	P1+P2+P3	P23	P2+P3+P5
P3	P3	P10	P2+P3	P17	P1+P2+P4	P24	P2+P4+P5
P4	P4	P11	P2+P4	P18	P1+P2+P5	P25	P3+P4+P5
P5	P5	P12	P2+P5	P19	P1+P3+P4		
P6	P1+P2	P13	P3+P4	P20	P1+P3+P5		
P7	P1+P3	P14	P3+P5	P21	P1+P4+P5		

(1) Register to the pattern key

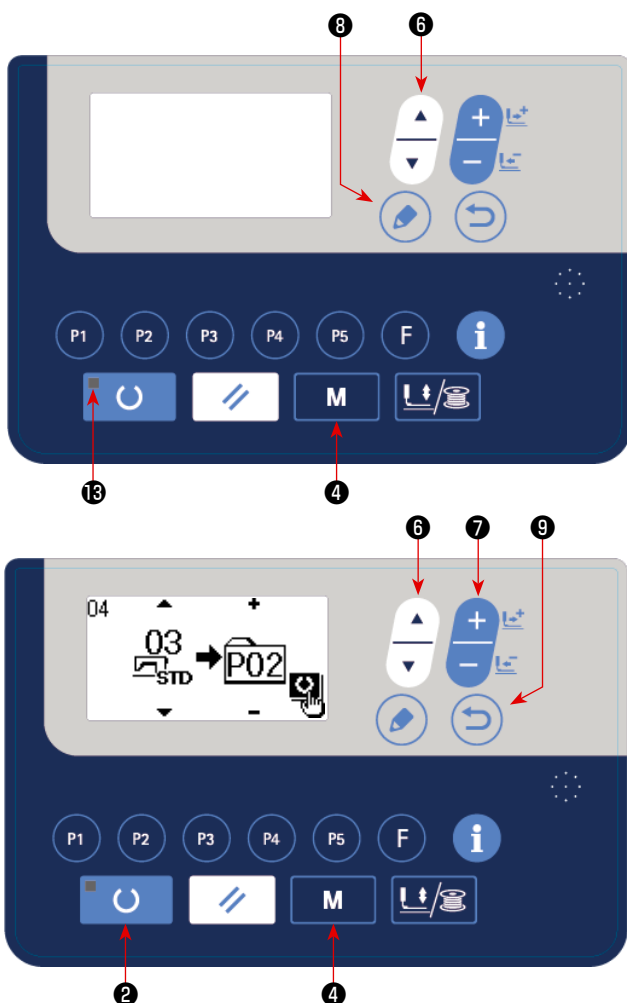

Setting example : Register following settings to the P2: Pattern No. 3; X scale rate: 50 %; Y scale rate: 80 %; maximum sewing speed limitation: 2000 sti/min; pattern position: 0.5 mm to the right and 1 mm to the front.



1) Turn ON the power switch and press MODE key  (4) to enter mode setting (memory switch setting). (SET READY LED  should be put out.)

Press ITEM SELECT key  (6) to bring "04. Direct pattern registration" to the selected state.

Press EDIT key  (8) to display the pattern registration mode.

2) Press ITEM SELECT key  (6) to set the standard pattern to No. 3. Press DATA CHANGE key  (7) to set P-No. to 2.

When you press the READY key  (2), P2 is registered and the mode screen is displayed.

Press MODE key  (4) or RETURN key

 (9).

* When the select key is held pressed for one second in the state where the standard pattern or user pattern is selected on the data input screen, this screen can be displayed.

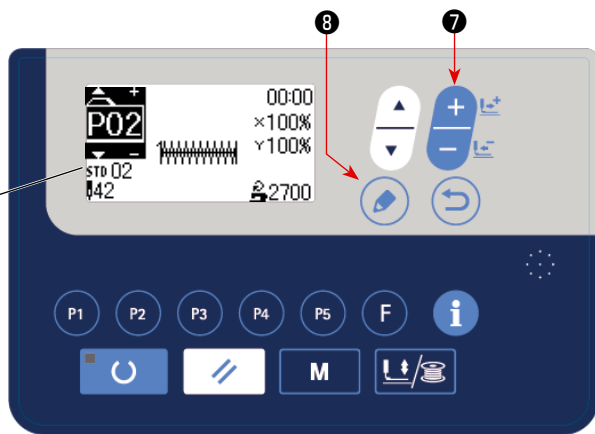

3) Press EDIT key  8 . Edit the item data with

DATA CHANGE key  7 .

The item data that can be edited are as described in "(2) Listing of item data" p.29 .

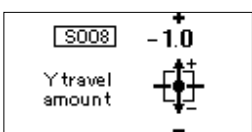
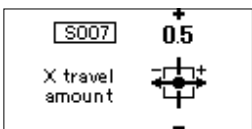
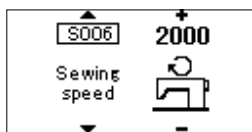
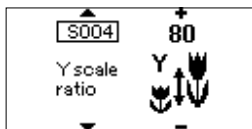
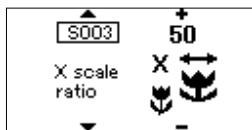

4) Set the X scale rate to "50" %, Y scale rate to "80" % and sewing speed to "2000" sti/min, respectively.

5) The "X enlargement/reduction ratio" display 0.0 is displayed by pressing EDIT key  8 .

The amount of travel in X direction can be set in increments of 0.1 mm. Change the set value to

"0.5" with DATA CHANGE key  7 .

6) The "Y enlargement/reduction ratio" display 0.0 is displayed by pressing EDIT key  8 .

The amount of travel in Y direction can be set in increments of 0.1 mm. Change the set value to

"-1.0" with DATA CHANGE key  7 .

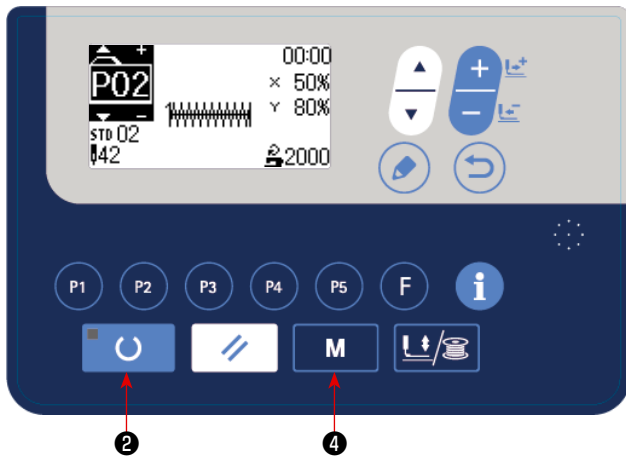











7) Press READY key  ② , key to finalize the setting.

8) Press MODE key  ④ .
Pattern register mode is finalized.

9) Press MODE key  ④ .
Mode setting is finalized and the mode returns to the normal mode.

(2) Listing of item data

No.	Item name	Pictograph	Input range	Remarks:
S001	Type of pattern		Standard pattern / User pattern	* This data is for display only. To edit the data, delete the direct pattern and create a new direct pattern.
S002	Pattern No.		Standard pattern : 1 to 51 User pattern : 1 to 200	* This data is for display only. To edit the data, delete the direct pattern and create a new direct pattern.
S003	X enlargement/ reduction scale/ actual dimension		When inputting in terms of percentage (%): 20 - 200 % When inputting an actual dimension: Within the range of actual dimensions corresponding to the percentage	Input method (percentage or actual dimension) can be selected by setting the memory switch U064. (Initial value: Input in percentage)
S004	Y enlargement/ reduction scale/ actual dimension		When inputting in terms of percentage (%): 20 - 200 % When inputting an actual dimension: Within the range of actual dimensions corresponding to the percentage	Input method (percentage or actual dimension) can be selected by setting the memory switch U064. (Initial value: Input in percentage)
S006	Sewing speed		400 to 2700	The maximum input range depends on the maximum sewing speed set with the memory switch U001.
S007	X travel amount		- 20 to 20	
S008	Y travel amount		- 20 to 10	
S009	2-step stroke work clamp stroke height		50 to 90	Display/hide of the stroke height can be selected using the memory switch U069. (Initial value: Hide) When the hide is selected, the stroke height is not displayed on the data edit screen.
S010	Position of the last stitch X travel amount		- 2.0 to 2.0	Display/hide of the stroke height can be selected using the memory switch U070. (Initial value: Hide) When the hide is selected, the stroke height is not displayed on the data edit screen.
S011	Position of the last stitch Y travel amount		- 2.0 to 2.0	Display/hide of the stroke height can be selected using the memory switch U070. (Initial value: Hide) When the hide is selected, the stroke height is not displayed on the data edit screen.
S012	Comment		The number of characters that can be input: 14	

(3) Sewing operation

Operation example : After performing sewing with the contents of the registered P2, perform sewing with the contents of P3.

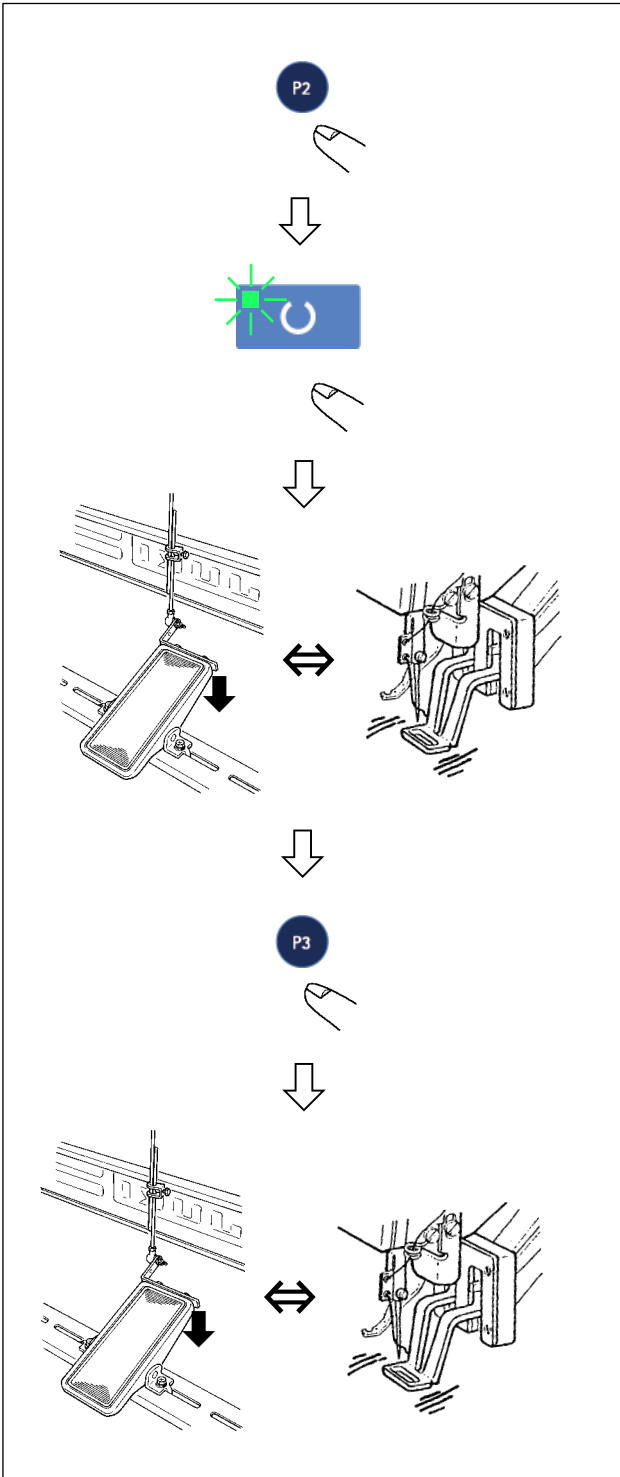



- 1) Turn ON the power switch.
 - 2) Press direct pattern **P2** .
 - 3) Press READY key  to light up SET READY LED . Once the LED lights up, the work clamp goes up after traveling.
 - 4) Check the contour of the sewing pattern.
(Refer to the item "I.5-4. Checking the contour of a sewing pattern" p.21.)
 - 5) If the contour of the sewing pattern is acceptable, the sewing can be made.
 - 6) After the completion of sewing, press direct pattern **P3** . Then, the work clamp comes down, retrieves the origin, travels to the sewing starting point and goes up. Then, the origin is retrieved. After the origin retrieval, the work clamp travels to the sewing starting point and goes up.(The P keys can operate the pattern change by one-touch even when the SET READY LED is lighting up.)
 - 7) Perform the above items 4) and 5).
- * P1 to P25 can be specified by selecting the pattern. Display the target pattern using DATA

CHANGE key  .

→ 0 to 200 ↔ P1 to 25 ←

P1 to P25 which have not been registered are not indicated.

 **Press P1 to P25 key while the SET READY LED lights up and the presser comes down. Be careful that your fingers are not caught in the presser.**

 **Pattern register from P26 to P50 can be performed. Register can not be performed in **P1** to **P5** key. Designate the pattern by the pattern selection only. Indicate the pattern with  key.**

→ 0 to 200 ↔ P1 to P25 ↔ P26 to P50 ←

Pattern selection from P26 to P50 cannot be performed while the SET READY LED lights up.

6-2. Sewing using the combination function (cycle sewing)

This sewing machine can perform sewing of plural sewing pattern data in one cycle in the order of the data. As many as 99 patterns can be input. Use this function for sewing two or more different patterns on the sewing product. In addition, registration of as many as 99 cycles can be performed. Copy and use the data to fill the needs.

→ Refer to "1.6-5. Copying or deleting various kinds of pattern data" p.38.

(1) Selection of cycle data

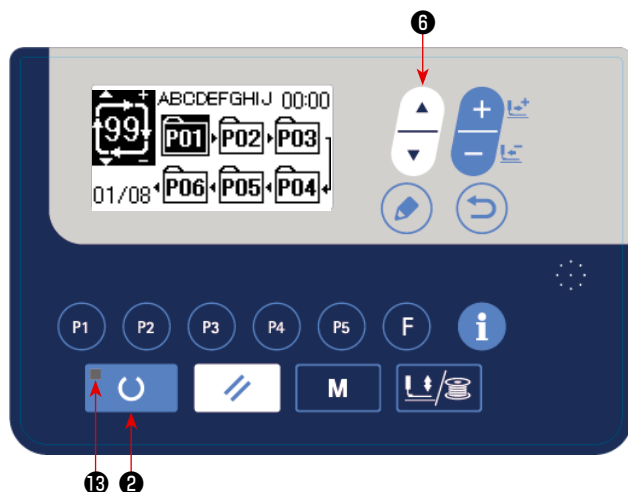

1) Set the mode to the input mode.

Under the input mode where SET READY LED 13 goes out, selection of the cycle data is enabled.

If the current mode is the sewing mode, press READY key 2 to change over the mode to the input mode.

Only under the input mode, selection of the cycle data is enabled.

2) Select cycle stitching data.

Press ITEM SELECT key 6, and patterns which have been registered are changed over and displayed in order. Cycle data No. and continuous stitching data No. which have been registered after the last registered pattern No. are displayed. Here, select the cycle data No. which you desire to sew.

3) Perform sewing.

When READY key 2 is pressed in the state where the cycle data is selected, SET READY LED 13 lights up to show that the sewing is enabled.

Cycle data No. 1 only has been registered at the time of your purchase. However, sewing status cannot be obtained since the sewing pattern has not been inputted. Perform inputting of sewing pattern referring to (2) Method of editing cycle data on the next page.

(2) Method of editing cycle data

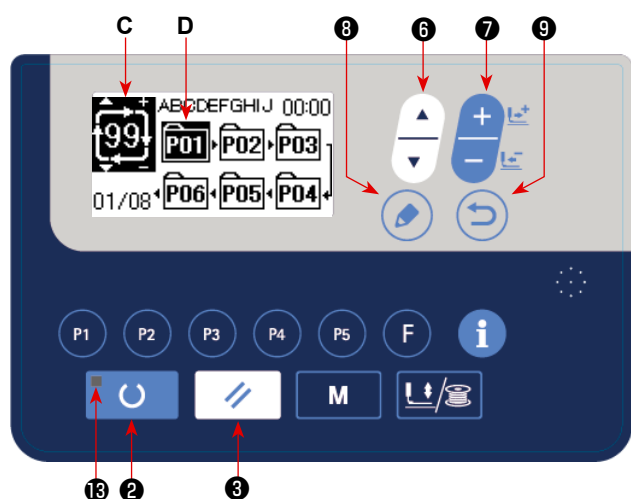

1) Set the mode to input mode.



Under the input mode where SET READY LED 13 goes out, entry of the cycle data is enabled.



If the current mode is the sewing mode, press READY key 2 to change over the mode to the input mode.

2) Set cycle data to editing status.

When EDIT key 8 is pressed, the cycle data editing display C appears on the screen. The pattern No. D to be sewn is displayed in reverse video. In this state, it is possible to edit the data.

3) Selecting the edit point

When you press ITEM SELECT key  ⑥, the edit point is changed and the current point is displayed in reverse video. When you move the edit point forward until the last point is reached, additional indication pictograph  is displayed.

When you press EDIT key  ⑧ while selecting the edit point, the additional indication pictograph  is displayed at the selected position to enable insertion of pattern data.

4) Change data of selected editing point.

Press DATA CHANGE key  ⑦ and data of editing point can be changed.

Pattern No. which has been registered is displayed and it is possible to select.

In addition, press RESET key  ③, and the pattern data of editing point can be deleted.

When RESET key  ③ is held pressed for one second, all the registered pattern data can be deleted.

Repeat steps 3) and 4) to perform editing data.

5) Cancelling insertion of pattern data

Insertion of the pattern data is cancelled and the mode is changed over to the input mode by pressing

RETURN key  ⑨.

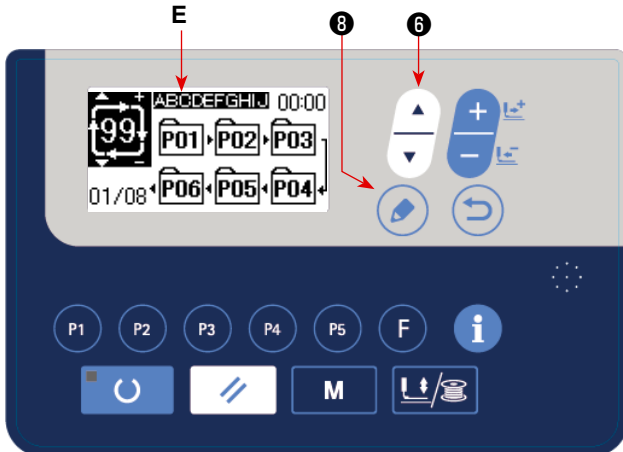

6) Editing the comment

Press ITEM SELECT key  ⑥ while the "cycle data editing" is displayed to display comment section **E** in the reverse video. The comment input screen is displayed by pressing EDIT key

 ⑧ while the comment section is being selected.

(Refer to "[I-5-3.\(4\) Setting the comment](#)" p.19 for how to input the comment.)

(3) Sewing operation

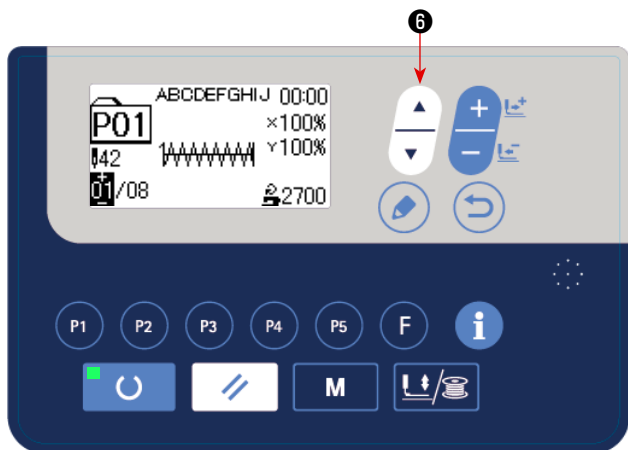
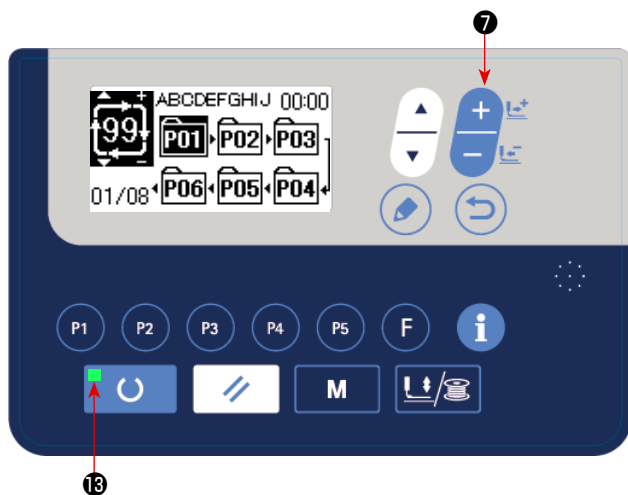
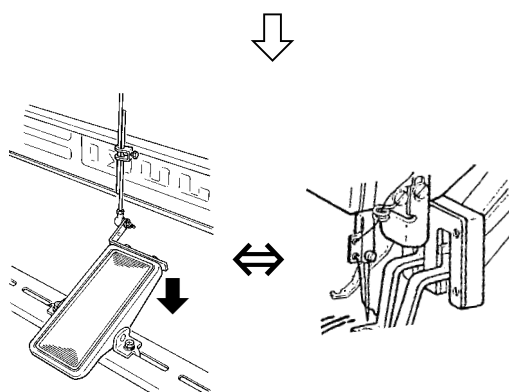



- 1) Turn the power ON.
- 2) Select the cycle pattern using ITEM SELECT key



6 . Select the cycle pattern number with



DATA CHANGE key 7 .

- 3) Press READY key  2 to light up SET READY LED  13 . Then, the work clamp goes up after travelling.

- 4) If the pattern shape is correct, start sewing.

- 5) The step of pattern numbers combined on a sewing-by-sewing basis advances until one cycle is completed. After the completion of the cycle, the sewing machine returns to the first step of the cycle to permit sewing in repetition.

- * When you want to return to the previous pattern after the completion of sewing or to skip the next

pattern, press DATA CHANGE key  7

while SET READY LED  13 lights up.

The pattern display changes and the work clamp travels to the sewing starting point.

- * Be aware that the contents of P1 to P50 used for C1 to C99 will be changed if you change the contents of P1 to P50 after the registration of C1 to C99.

- * Check the pattern shape on a pattern-by-pattern basis. (Refer to "[I.5-4. Checking the contour of a sewing pattern](#)" p.21.)

- * When you press ITEM SELECT key  6 on

the sewing screen, the details of the pattern to be sewn can be displayed.

6-3. Sewing through the use of the counter

For this sewing machine, the progress rate and the operation rate of the sewing machine can be displayed by setting the sewing counter and the production parameter.

Refer to "[I.6-10. Production support function](#)" p.45 for how to use the progress rate and the operation rate.

[Production counter]

(1) How to set the sewing counter

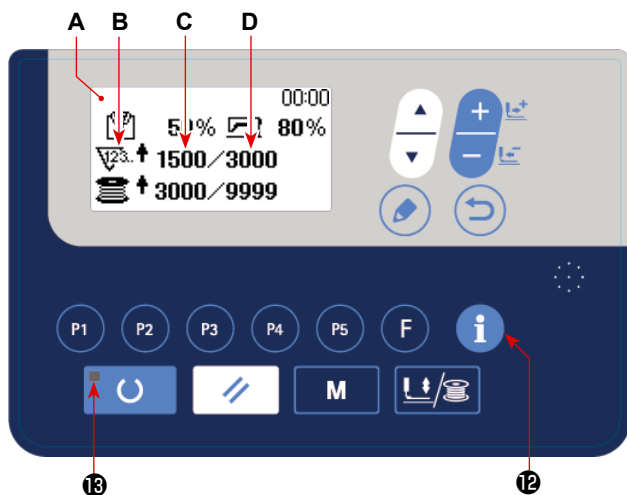

1) Calling the production counter screen

Under the input mode where READY LED (B) goes out, press INFORMATION key (i) (12) to display the production counter screen A.

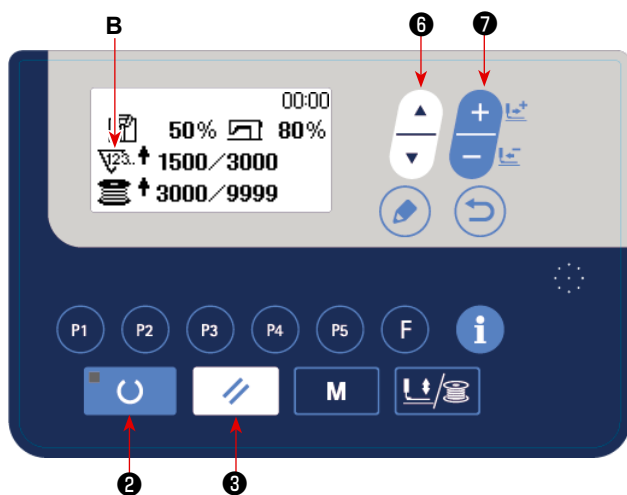

2) Type of the counter

For the type of counter for the sewing counter, only the increment counter B is available.

3) Changing the set value for the "number of pieces to be produced per day"

Select ITEM SELECT  (6) to display the "target number of pieces to be produced per day" D in the reverse video.

Enter the target number of pieces to be produced per day by pressing DATA CHANGE key  (7).

4) Changing the current value of the "number of pieces to be produced per day"

Press ITEM SELECT key  (6) to display the current value C of the "number of pieces to be produced per day" in the reverse video.

The numeric value can also be edited using DATA CHANGE key  (7).

(2) Completion of counting

The count completion screen has been factory-set to "disabled" at the time of shipment.

In order to use the count-completion screen for the sewing counter, set the memory switch U077 to "Enable display". (Refer to "[1.8-2. List of the memory switch functions](#)" p.60.)

[Bobbin thread counter]

(1) How to set the bobbin thread counter

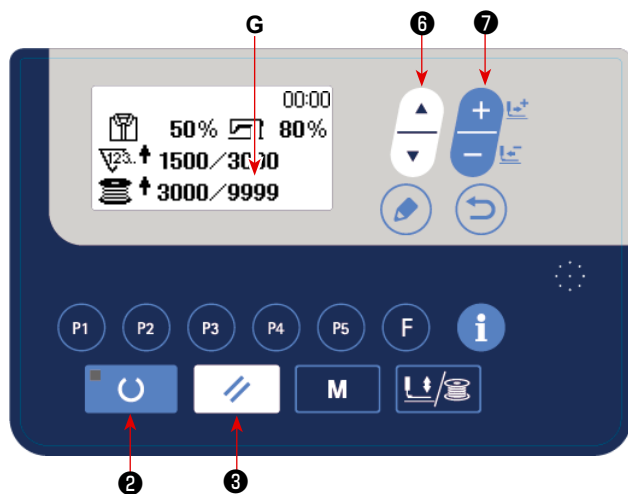
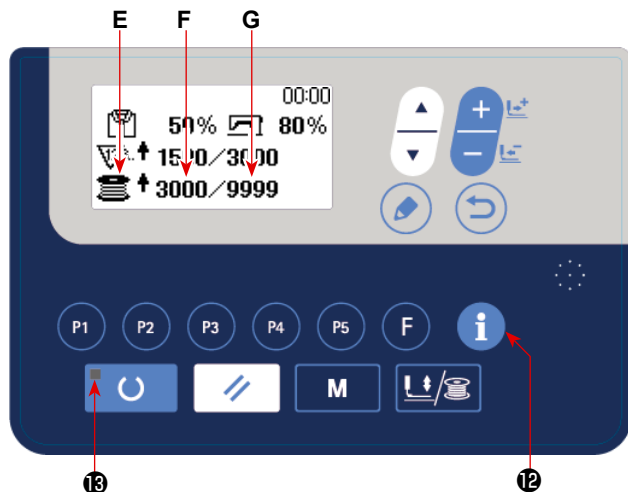

1) Selection of kinds of counters

Press ITEM SELECT key  ⑥ to display the pictograph **E** which indicates the counter type in reverse video.

Press DATA CHANGE key  ⑦, and select the counter you desire from among the kinds of counters below.

2) Changing the set value for the bobbin thread counter

Press ITEM SELECT key  ⑥ to display the set value **G** for the bobbin thread counter in the reverse video.

Enter the set value to be counted until this value is reached by pressing DATA CHANGE key



3) Changing the current value of the bobbin thread counter

Press ITEM SELECT key  ⑥ to display the current value **F** of the counter in reverse video.

In addition, It is possible to edit the numeric value by DATA CHANGE key  ⑦.

(2) Type of the bobbin thread counter

① Bobbin thread count-up counter



The current value displayed on the bobbin thread counter is increased by one every time the sewing machine sews 10 stitches. When the current value becomes equal to the set value, the count complete screen is displayed.

② Bobbin thread count-down counter





The current value displayed on the bobbin thread counter is decreased by one every time the sewing machine sews 10 stitches. When the current value becomes 0 (zero), the count complete screen is displayed.

③ Counter not used



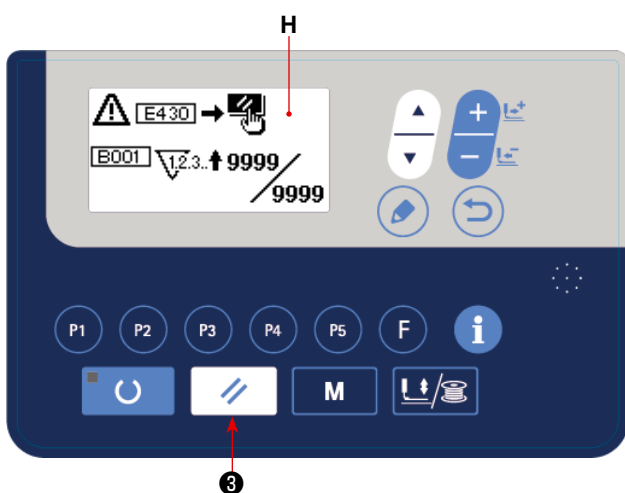

(3) How to reset the counter after the counter completes counting

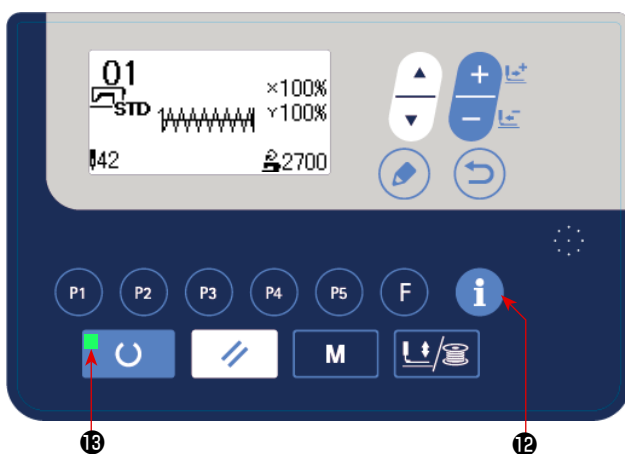

- 1) When count-up condition is reached during sewing work, the whole count-up screen **H** flashes on and off. Press RESET key  ③ to reset the counter, and the mode returns to the sewing mode. Then the counter starts counting again.

(4) How to check the counter in the set-ready state





Under the sewing mode where SET READY LED ⑬ lights up, press INFORMATION key  ⑫ to display the production counter screen. On this screen, the counter can be checked.

6-4. How to use the temporary stop

Once the RESET key function is set to the "pause" by means of the memory switch U031, the RESET key will function as the pause key to allow the sewing machine to be stopped during sewing. (Refer to "[I.8-2. List of the memory switch functions](#)" p.60.)



1) The sewing machine is stopped by pressing RESET key  ③.

When you press RESET key  ③, the error is reset and the thread trimming screen is displayed. When press RESET key  ③ again, the thread trimmer operates to trim the thread and the feed forward / backward screen is displayed.

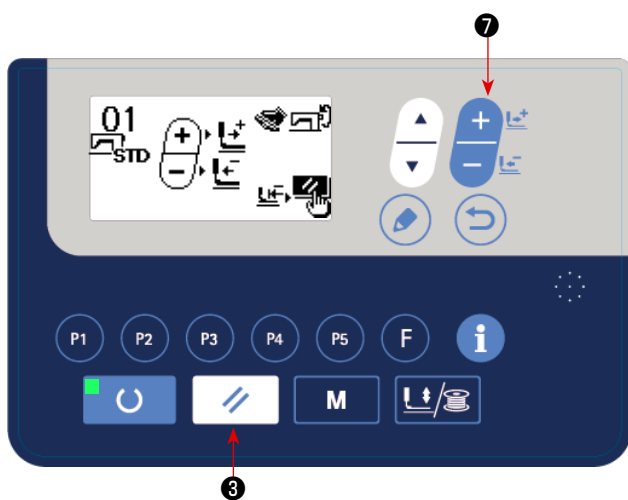

2) Three operations can be carried out after the error is reset.

1. Re-starting of sewing with the start switch
2. Adjust the positioning with DATA CHANGE key



⑦ . Press the START switch to re-start the sewing machine.

3. Press RESET key  ③ to return the sewing machine to the origin.

6-5. Copying or deleting various kinds of pattern data

Data of pattern No. which has been already registered can be copied to pattern No. which has not been used. Overwriting copy of the pattern is prohibited. When you desire to overwrite, perform it after erasing the pattern once.

The patterns that can be copied are the following three types.

- * To copy a standard pattern and user pattern to another user pattern.
- * To copy the pattern key
- * To copy the cycle pattern

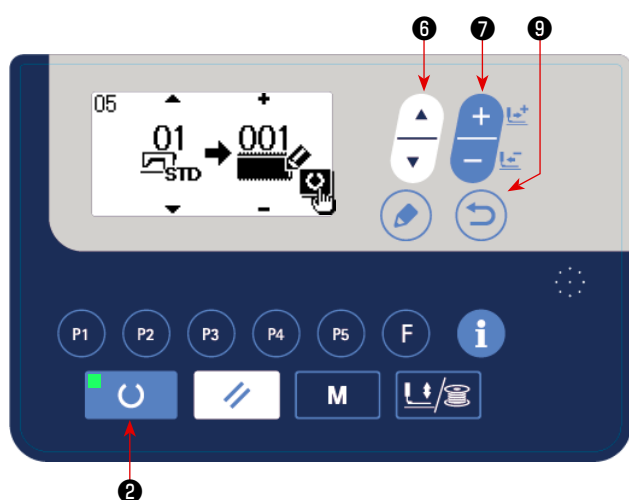
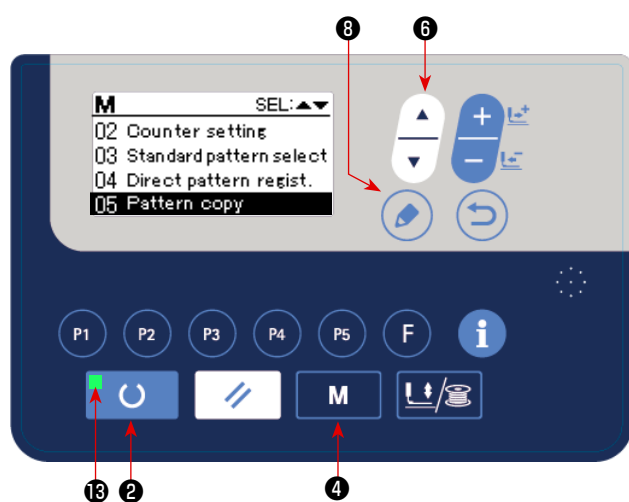



1) Set the mode to input mode.

Under the input mode where SET READY LED 13 goes out, copy is enabled.

If the current mode is the sewing mode, press READY key  2 to change over the mode to the input mode.

2) Displaying the mode screen

Press MODE key  4 to display the mode screen. Put the pattern copy in the selected state with ITEM SELECT key  6. Then, press EDIT key  8.

3) Call copy screen.

Press ITEM SELECT key  6 to select the source pattern number for copying.

The type of pattern that can be selected is the standard pattern and user pattern. Only the pattern numbers which have been registered are displayed.

When you press RETURN key  9, the copy function is cancelled and the screen returns to the mode screen.





4) Select pattern No. of copy destination.

Press DATA CHANGE key  7 to select the pattern number to be copied.

5) Start copying.

When READY key  2 is pressed, the copy starts. Then, the screen returns to the input screen on which the pattern No. which is created by copying is selected.



6) Erasing the pattern

In the case of erasing the pattern, select ITEM SELECT key  ⑥ to select the pattern number you want to delete. Press DATA CHANGE key  ⑦ to select Trash . Then, press READY key  ②. The delete confirmation screen is displayed. The pattern is deleted by pressing RESET key  ③ on this screen.

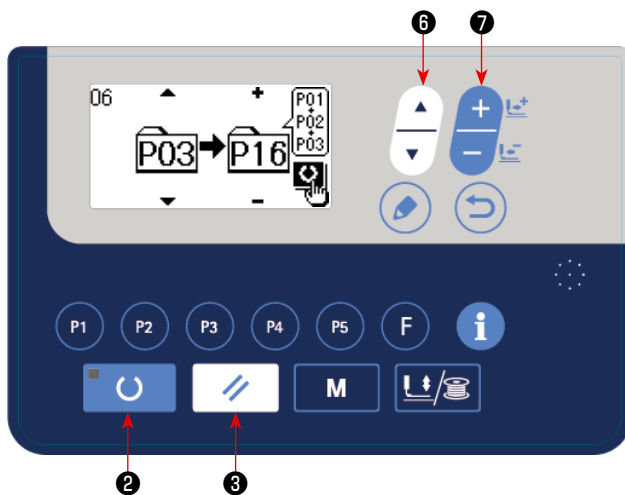

* The standard pattern cannot be deleted.

* In the case of copying the direct pattern, select "06 Direct pattern copy" on the mode screen. In the case of copying the cycle pattern, select "07 Cycle pattern copy" on the mode screen. Both the direct pattern and the cycle pattern can be copied in the similar procedure.

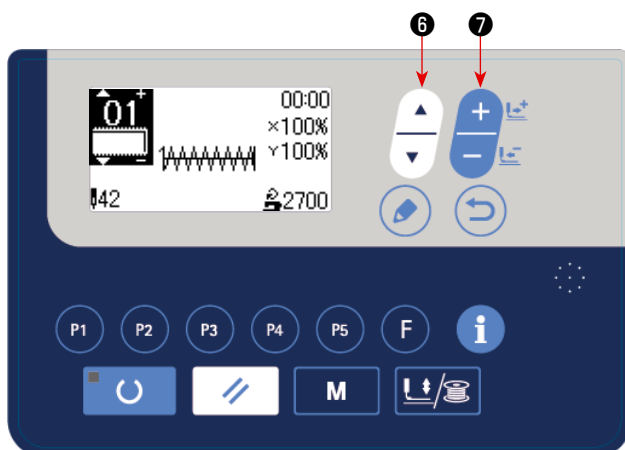
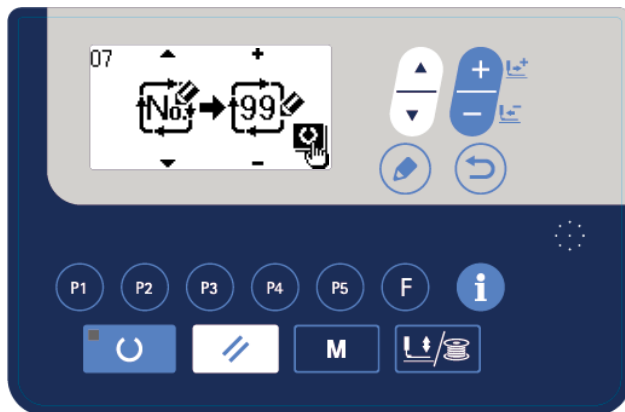

* The pattern key and the cycle pattern can be copied in the similar procedure. To create a new cycle pattern, press ITEM SELECT key  ⑥ to select new creation .



* To select a copied user pattern, press ITEM SELECT key  ⑥ to display  when the pattern number is displayed on the upper left section of the screen. Then, press DATA CHANGE key  ⑦ to select a pattern number.

6-6. Communication

(1) USB thumb drive

- ① Precautions to be taken when handling USB devices
- Do not leave the USB device or USB cable connected to the USB port while the sewing machine is in operation. The machine vibration can damage the port section resulting in loss of data stored on the USB device or breakage of the USB device or sewing machine.
 - Do not insert/remove a USB device during reading/writing a program or sewing data. It may cause data breakage or malfunction.
 - When the storage space of a USB device is partitioned, only one partition is accessible.
 - Some type of the USB device may not be properly recognized by this sewing machine.
 - JUKI does not compensate for loss of data stored on the USB device caused by using it with this sewing machine.
 - When the panel displays the communication screen or pattern data list, the USB drive is not recognized even if you insert a medium into the slot.
 - For USB devices and media such as CF(TM) cards, only one device/medium should be basically connected/inserted to/into the sewing machine. When two or more devices/media are connected/inserted, the machine will only recognize one of them. Refer to the USB specifications.
 - Insert the USB connector into the USB terminal on the IP panel until it will go no further.
 - Do not turn the power OFF while the data on the USB flash drive is being accessed.
- ② USB specifications
- Conform to USB 1.1 standard
 - Applicable devices *1 ___ Storage devices such as USB memory, USB hub, FDD and card reader
 - Not-applicable devices ___ CD drive, DVD drive, MO drive, tape drive, etc.
 - Format supported ___ FD (floppy disk) FAT 12
___ Others (USB memory, etc.), FAT 12, FAT 16, FAT 32
 - Applicable medium size _ FD (floppy disk) 1.44MB, 720kB
_ Others (USB memory, etc.), 4.1MB ~ (2TB)
 - Recognition of drives ___ For external devices such as a USB device, the device which is recognized first is accessed. However, when a medium is connected to the built-in media slot, the access to that medium will be given the highest priority. (Example: If a medium is inserted into the media slot even when the USB memory has already been connected to the USB port, the medium will be accessed.)
 - Restriction on connection _ Max. 10 devices (When the number of storage devices connected to the sewing machine has exceeded the maximum number, the 11th storage device and beyond will not be recognized unless they are once disconnected and re-connected.)
 - Consumption current ___ The rated consumption current of the applicable USB devices is 500 mA at the maximum.



*1: JUKI does not guarantee operation of all applicable devices. Some device may not operate due to a compatibility problem.

(2) How to use the communication function

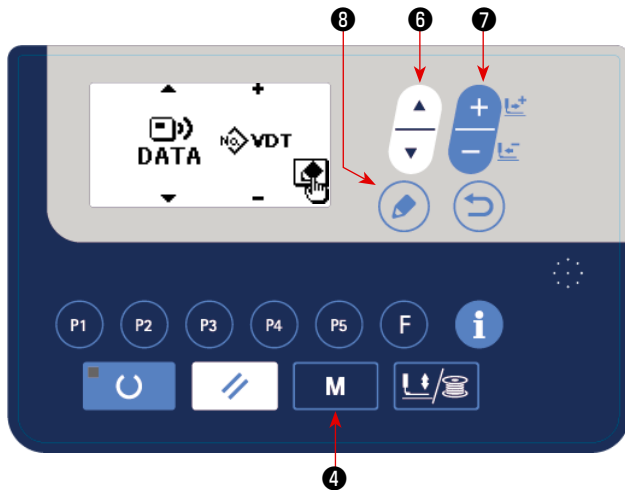
This sewing machine is capable of inputting/outputting data by means of an USB thumb drive.



1) Entering the communication mode.

Press MODE key **M** ④ to display the mode screen. Put the pattern copy in the selected state with ITEM SELECT key  ⑥. Then, press EDIT key  ⑧.

2) Selecting the type of communication.

Press DATA CHANGE key  ⑦ to select the type of communication.

Name of data		Extension	Description of data
Vector form data		VD00 xxx .VDT (xxx : 001 to 999)	Data on needle entry points created with the PM-1. The data form is commonly used among JUKI sewing machine.(User pattern)

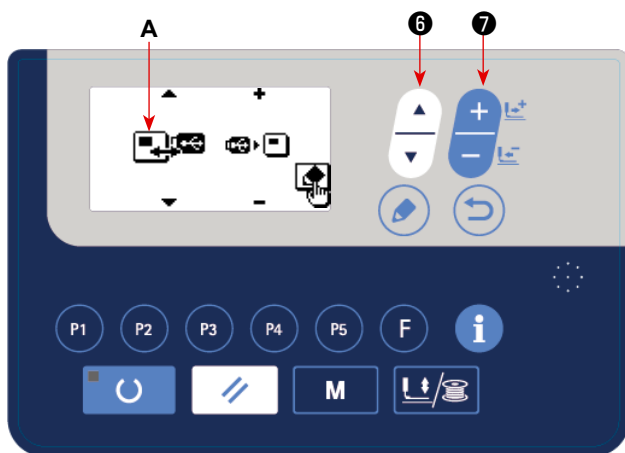

3) Selecting the communication direction

Press ITEM SELECT key  ⑥ to display pictograph **A** which shows the communication direction selection.

Press DATA CHANGE key  ⑦ to select the communication direction.

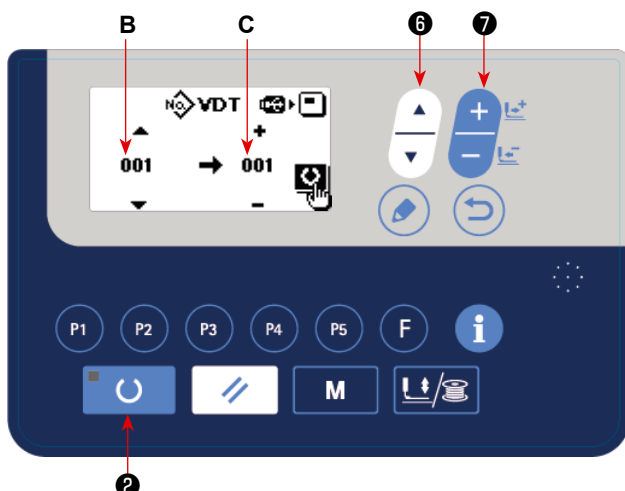

 : Data shown on the operation panel is written on the USB thumb drive.

 : Data stored on the USB thumb drive is read into the operation panel.



4) Selecting the number.

Press ITEM SELECT key  ⑥ to select file No. **B** to be read.

Press DATA CHANGE key  ⑦ to select file No. **C** to be written. Press set READY key  ② to write the data in file No. **C**.

6-7. Cautions in operation

- (1) When the error indicator lamp lights up, be sure to check the cause of trouble and take a proper corrective measure.
- (2) Do not draw, by hand, the material being sewn during sewing. Doing so will cause the needle shift from the correct position. If the needle moves from the correct position, press READY key  two times. This will return the needle to the normal origin.
- (3) Do not turn OFF the power in a state that the needle is lowered. The presser comes down and the wiper interferes with needle. As a result, there is a danger of needle breakage or the like.

Reference for the sewing speed to be applied

Sewn product / thread / needle	Head type / Sewing speed
8-layered denim / Cotton thread #50 / DP×5 #16	S (Standard) / 2,700 sti/min
8-layered denim / Cotton thread #20 / DP×17 #19	H (Heavy-weight material) / 2,700 sti/min
Overlapped sewing of 6×12-layered denim / Cotton thread #20 / DP×17 #19	H (Heavy-weight material) / 2,500 sti/min
8-layered woolen gabardine / Polyester filament #50 / DP×5 #14	S (Standard) / 2,300 sti/min

* To prevent the thread breakage due to the needle heat, set the sewing speed referring to the above table in accordance with the sewing conditions.

6-8. Setting enable/disable of standard pattern invoking

Invoking of a wrong pattern is prevented by disabling invoking of unnecessary patterns.
In addition, necessary patterns can be invoked and used.

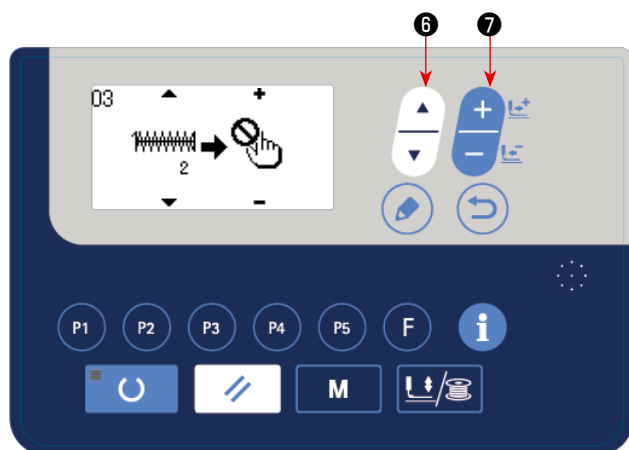

Example of setting: Invoking of pattern No. 2 is disabled.

1) Putting the sewing machine in the input mode
Under the input mode where the SET READY LED **13** goes out, setting of data is enabled.
Under the sewing mode, press READY key  **2** to change over the mode to the input mode.

2) Press MODE key  **4** to display the mode screen. Set the standard pattern use/disuse selection in the "use" state with ITEM SELECT key



6. Then, press the select key.

3) Press ITEM SELECT key  **6** to display pattern No. 2.

4) Press DATA CHANGE key  **7** to select use/disuse of the pattern.

 : Use

 : Disuse

6-9. How to use the F key

Use F key **F** ⑪ after registering the parameter you frequently use to it.

The registered parameter can be selected only by pressing F key **F** ⑪ under the input mode.

(1) Method of register

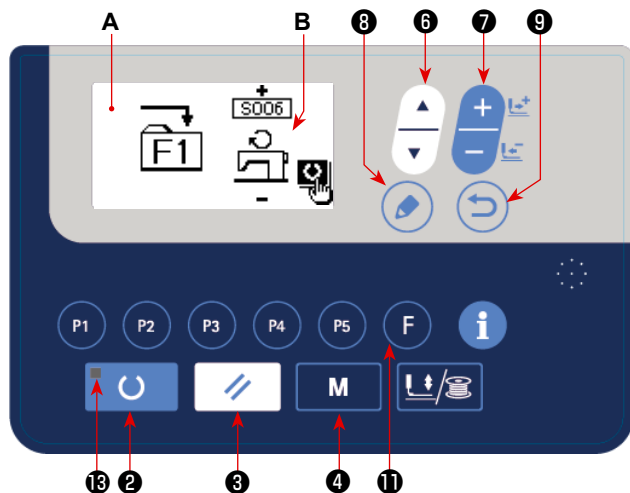

1) Set the mode to the input mode

Under the input mode where SET READY LED ⑬ goes out, parameter registration is enabled. If the current mode is the sewing mode, press READY key  ② to change over the mode to the input mode.

2) Calling the F key setting screen

When you keep F key **F** ⑪ held pressed, the F key setting screen **A** is displayed.

3) Select parameter

Item **B** which can be registered to the key is displayed. Press ITEM SELECT key  ⑥ to select the item to be registered.

The items that can be registered are; direct-pattern item data and memory switch 1 item.

4) Start register.

When READY key  ② is pressed, registration starts, and the screen returns to the mode screen.

When RETURN key  ⑨ is pressed, the screen returns to the previous screen without performing registration.

(2) State of registration at the time of purchase

"[S006] Sewing speed" is registered to the F key at the time of purchase.

6-10. Production support function

This function displays the number of pieces produced for the day, calculates the progress rate of sewing work based on that number of pieces, and displays the result.

In addition, this function calculates the operation rate of the sewing machine based the operating hours of the sewing machine, and displays the result.

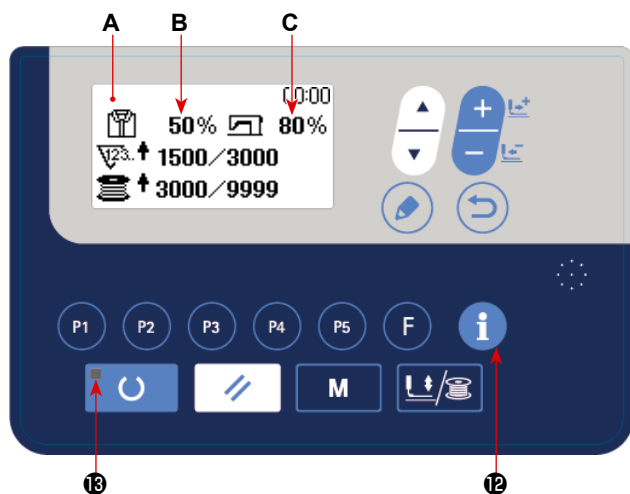

1) How to display the production information screen

Under the input mode where the SET READY LED 13 goes out, press INFORMATION key

 12 display the production counter screen A.

Set the production parameters in order to use the progress rate display B and the operation rate display C.

[Progress rate of sewing work]

Number of pieces to be produced per day / current target number of pieces × 100

* The current number of pieces produced is calculated from the current time, work hours (from the start time to the end time of work hours) and work breaks.

[Operation of rate of the sewing machine]

Time during the sewing machine runs / Working hours for the day

* Daily working hours is calculated from the current time, work hours (from the starting time to the closing time of work hours) and work breaks.

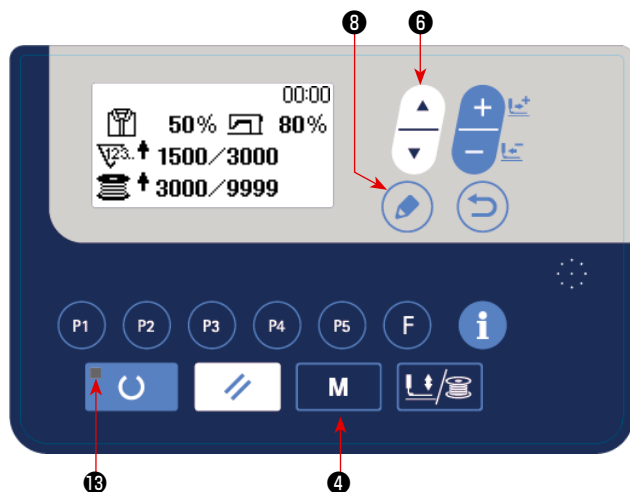

2) Displaying the production parameters

Under the input mode where SET READY LED 13 goes out, keep MODE key M 4 held pressed to display the mode screen.

Select "15. Production parameters" by pressing

ITEM SELECT key  6 .

Display the production parameter screen by

pressing EDIT key  8 .

The menu shown in the following table is displayed on the production parameter setting screen.

No.	Menu on the production parameter setting screen
1	Date and time setting
2	Number of times of thread trimming for counting one piece
3	Work hours setting
4	Work break 1
5	Work break 2
6	Work break 3
7	Display type of the target number of pieces

(1) Date and time setting

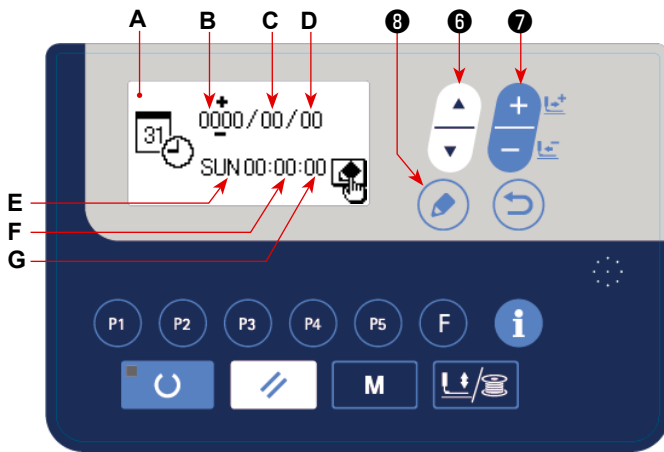

1) Calling the date and time setting screen

Select the date and time setting on the production parameter setting screen. In this

state, press EDIT key  8 .

The date and time setting screen is displayed

A.

2) Setting the date and time

When you press ITEM SELECT key  6 , the dominical year B ⇒ Month C ⇒ Day D ⇒ Hour F ⇒

Minute G are displayed in the reverse video. Select the target item you want to change and display it in

the reverse video. Enter the set value using DATA CHANGE key  7 .

* **Once the dominical year, month and day settings are changed, the display of the day of the week will automatically be changed accordingly.**

3) Determining the date and time set values

The set values are determined by pressing EDIT key  8 .

Then, the screen returns to the production parameter setting screen.

(2) Setting the work hours

Set the work hours that is required to calculate the progress rate and the operation rate for the production support function.

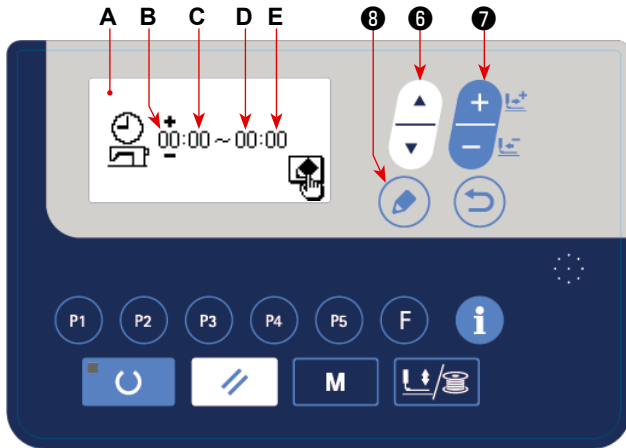

1) Calling the work hours setting screen

In the state where the work hours setting is selected on the production parameter setting screen, press EDIT key  8 .

The work hours setting screen is displayed A.

2) Setting the starting time of work hours

Press ITEM SELECT key  6 to display the starting hour (minute C) of work hours B in the reverse video.

Change the starting hour B (minute C) of work

hours by pressing DATA CHANGE key  7 .

3) Setting the closing time of work hours

Press ITEM SELECT key  6 to display the closing hour D (minute E) of work hours in the reverse video.

Change the closing hour D (minute E) of work hours by pressing DATA CHANGE key  7 .

4) Determine the set values of work hours

The set values are determined by pressing EDIT key  8 .

Then, the screen returns to the production parameter setting screen.

(3) Setting the number of times of thread trimming for sewing one piece of product

Set the number of times of thread trimming to be carried out until the production counter completes counting.

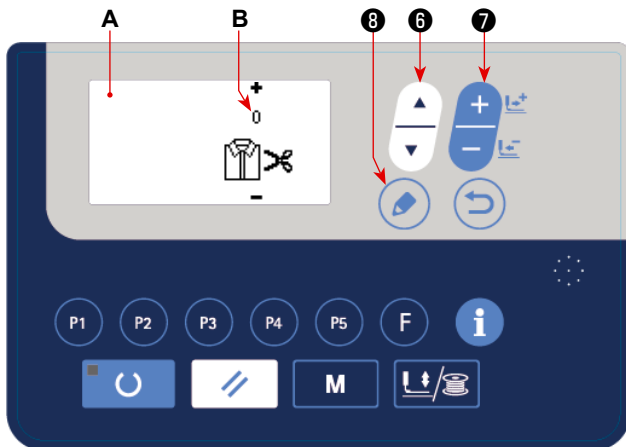

1) Calling the count complete unit setting screen

Calling the count complete unit setting screen

EDIT key  ⑧ .

The count complete unit setting screen is displayed **A**.

2) Setting the count complete unit

Enter the set value for the count complete unit **B** for the production counter by pressing DATA

CHANGE key  ⑦ .

3) Determining the count complete unit set value

The set value is determined by pressing EDIT key  ⑧ . Then, the screen returns to the production parameter setting screen.

(4) Setting the work break time

Set the work break time that is excluded from the calculation of the progress rate for the production support function.

As many as three work break times can be set.

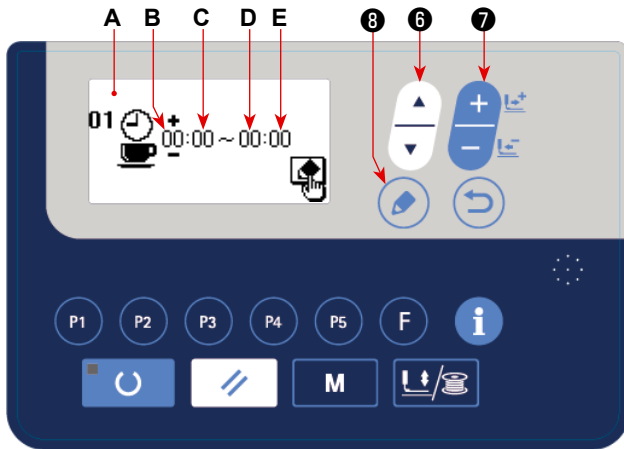

1) Calling the work break time 1 setting screen

In the state where the work break time 1 is selected on the production parameter setting

screen, press EDIT key  8 .

The work break time 1 setting screen is displayed A.

2) Setting the starting time of work break

Press ITEM SELECT key  6 to display the

starting time of work break hour B (minute C) in the reverse video.

Enter the set value for the work break hour B (minute C) by pressing DATA CHANGE key



3) Setting the closing time of work break

Press ITEM SELECT key  6 to display the closing hour D (minute E) of work break in the reverse

video. Change the closing hour D (minute E) of work hours by pressing DATA CHANGE key  7 .

4) Determine the set values of work break

The set values are determined by pressing EDIT key  8 . Then, the screen returns to the production parameter setting screen. If there are other work breaks, carry out setting of the work break 2 and work break 3 by selecting them on the production parameter screen.

(5) Calling the screen for setting the display type of the target number of pieces

Set the display type of the target number of pieces to be used for the production support function.

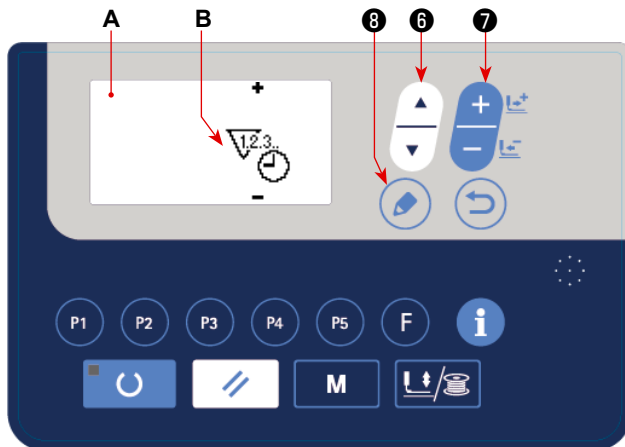



1) Calling the screen for setting the display type of the target number of pieces

Select the display type of the target number of pieces on the production parameter setting screen. In this state, press EDIT key  ⑧.

The display type setting screen **A** for the target number of pieces is displayed.

2) Setting the display type of the target number of pieces

Enter the display type **B** set value with DATA CHANGE key  ⑦.

 12.3 : The target number of pieces per day is displayed.

 12.3 : The target number of pieces until the current time is displayed.

3) Determining the setting of the display type of the target number of pieces

When you press EDIT key  ⑧, the set value is determined and the screen is returned to the production parameter setting screen.

7. MAINTENANCE

7-1. Adjusting the height of the needle bar



WARNING :

Turn OFF the power before starting the work so as to prevent accidents caused by abrupt start of the sewing machine.

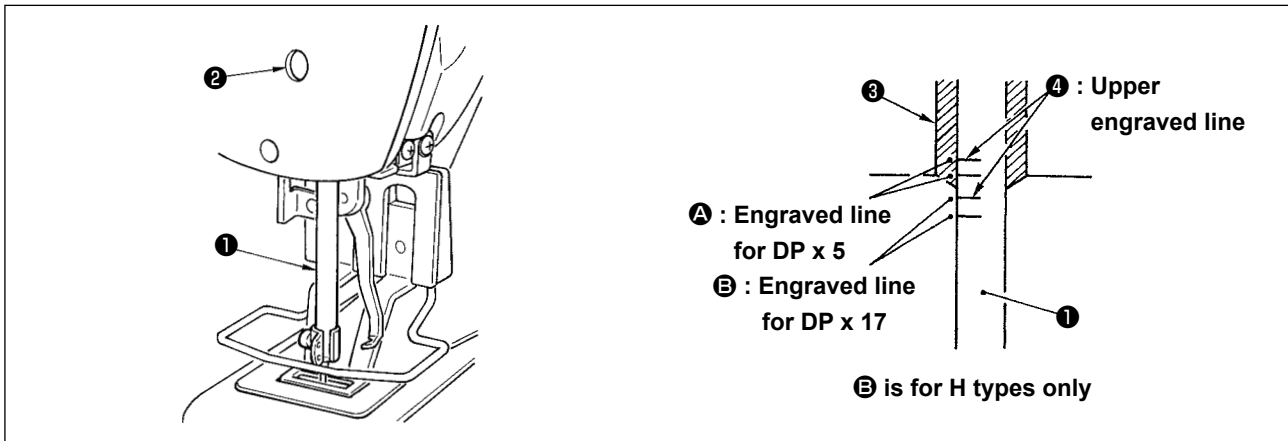

Bring needle bar ① to the lowest position of its stroke. Loosen needle bar connection screw ② and adjust so that upper marker line ④ engraved on the needle bar aligns with the bottom end of needle bar bushing, lower ③.



After the adjustment, make sure that there is no uneven torque.

* When stitch skipping occurs in accordance with the sewing conditions, adjust the height of the needle bar so as to lower it by 0.5 to 1 mm from the needle bar engraved line ④.

7-2. Adjusting the needle-to-shuttle relation



WARNING :

Turn OFF the power before starting the work so as to prevent accidents caused by abrupt start of the sewing machine.

Relation between needle and engraved lines

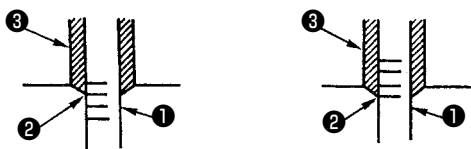

- 1) Turn the handwheel by hand. When needle bar ① has gone up, adjust so that lower marker line ② engraved on the needle bar aligns with the bottom end of the needle bar bushing ③, lower.

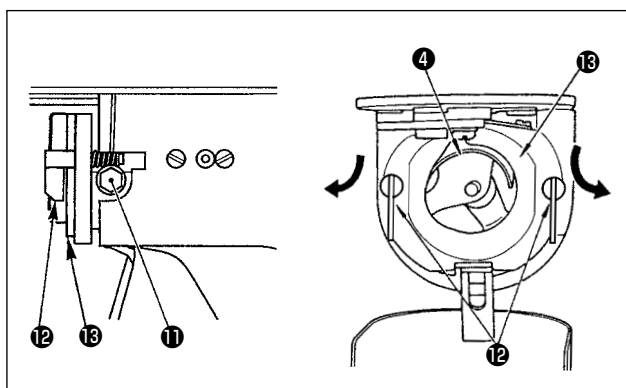

- 2) Loosen setscrew ⑪ in the driver. Open inner hook pressers ⑫ to the right and left, and remove inner hook presser ⑬.

Caution At this time, be careful not to let inner hook ④ come off and fall.

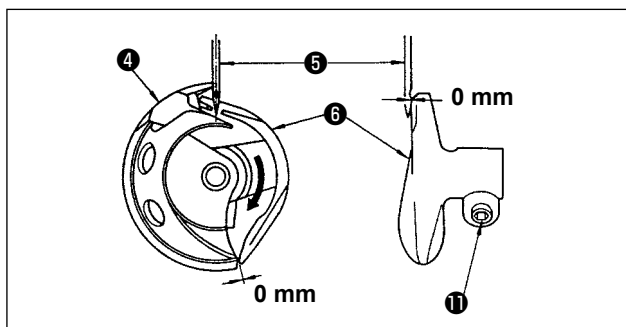

- 3) Adjust so that the blade point of inner hook ④ aligns with the center of needle ⑤, and that a clearance of 0 mm is provided between the front end of the driver and the needle as the front end face of driver ⑥ receives the needle to prevent the needle from being bent. Then tighten setscrew ⑪ of the driver.

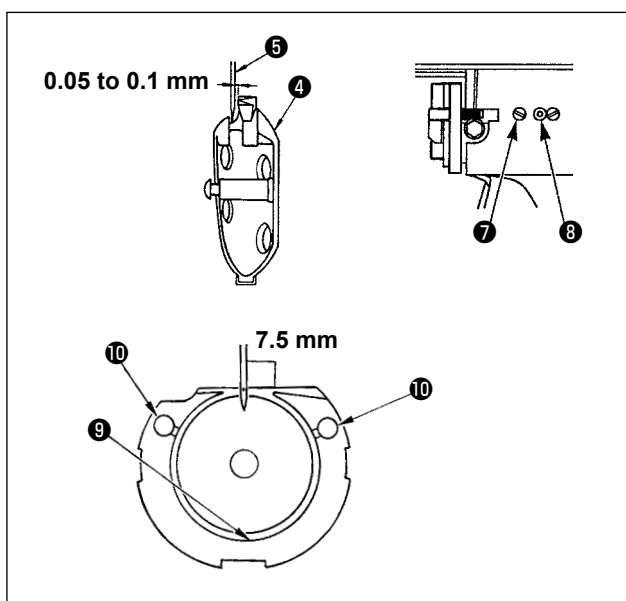

- 4) Loosen setscrew ⑦ of the shuttle, and adjust the longitudinal position of the shuttle. To do this adjustment, turn shuttle race adjusting shaft ⑧ clockwise or counterclockwise to provide a 0.05 to 0.1 mm clearance between needle ⑤ and the blade point of inner hook ④.

- 5) After adjusting the longitudinal position of the shuttle, further adjust to provide a 7.5 mm clearance between the needle and the shuttle by adjusting the rotating direction. Then tighten setscrew ⑦ of the shuttle.

Caution If the sewing machine is left unused for a long time, or after clearing the area surrounding the hook section, apply a little quantity of oil to race section ⑨ and felt ⑩ before using the sewing machine.

7-3. Adjusting the lift of the work clamp foot



WARNING :

As the work is performed while the power is ON, never touch the switches other than the necessary one so as to prevent accidents caused by the malfunction of switches.

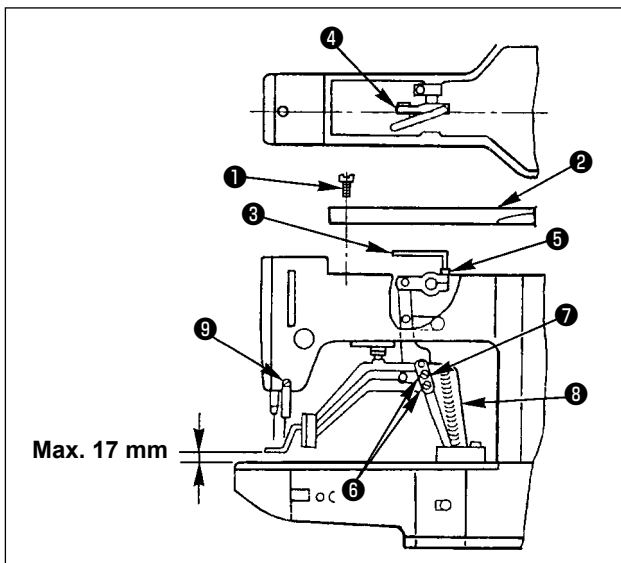

- 1) With the machine in stop mode, remove six set-screws **1** of the top cover, and take off top cover **2**.
- 2) Apply L-shaped wrench **3** to socket bolt **5** of clamp **4**, and loosen the socket bolt.
- 3) Push down L-shaped wrench **3** to increase the lift of the work clamp foot, or pull it up to decrease the lift.
- 4) After the adjustment, securely tighten socket bolt **5**.
- 5) If the right and left work clamp feet are not levelled, loosen fixing screw **6** and adjust the position of the work clamp foot lever support plate **7** to level them.



At this time, be careful not to cause work clamp foot lever support plate **7** to interfere with feed bracket **8**.

If the work clamp foot lever support plate interferes with the wiper, readjust the height of the wiper using setscrew **9** in the wiper installing base.

7-4. The moving knife and counter knife



WARNING :

Turn OFF the power before starting the work so as to prevent accidents caused by abrupt start of the sewing machine.

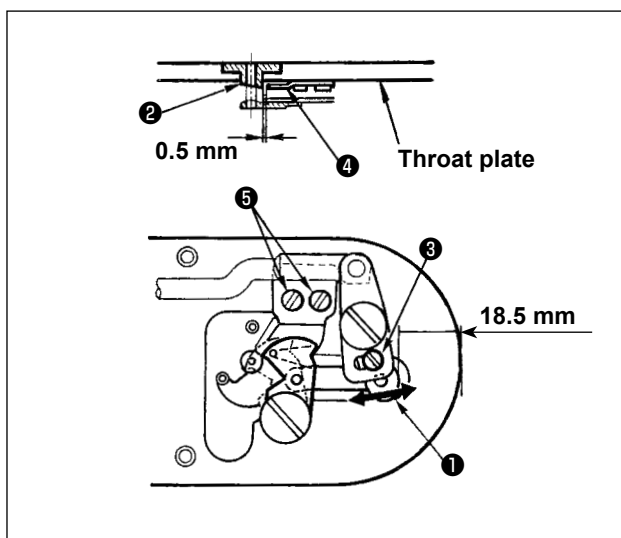

- 1) Loosen adjusting screw **3** so that a clearance of 18.5 mm is provided between the front end of the throat plate and the top end of thread trimmer lever, small **1**. To adjust, move the moving knife in the direction of arrow.
- 2) Loosen setscrew **5** so that a clearance of 0.5 mm is provided between needle hole guide **2** and counter knife **4**. To adjust, move the counter knife.

7-5. Adjustment of the wiper



WARNING :

Turn OFF the power before starting the work so as to prevent accidents caused by abrupt start of the sewing machine.

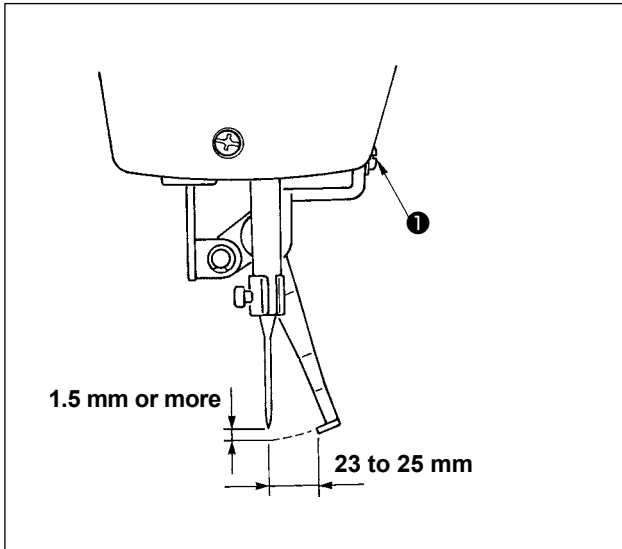

- 1) Loosen screw ❶ to adjust so that a clearance of 1.5 mm or more is provided between the wiper and the needle.

At this time, the standard of the distance between the wiper and the needle is 23 to 25 mm. By adjusting the distance wide, the work clamp foot can prevent stepping on needle thread when it comes down.

Especially when the thin needle is used, adjust the distance wide to such an extent of 23 mm.

- * The position of the needle is when the sewing machine has stopped after the sewing finished.

7-6. Draining waste oil

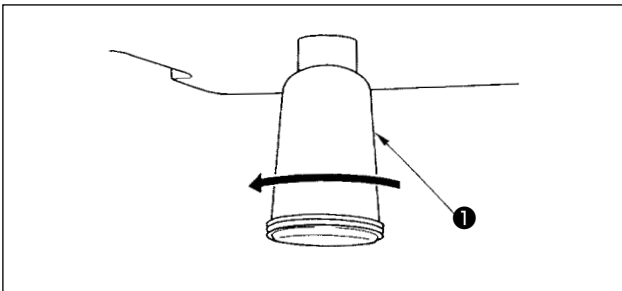

When polyethylene oiler ❶ becomes filled with oil, remove polyethylene oiler ❶ and drain the oil.

7-7. Amount of oil supplied to the hook

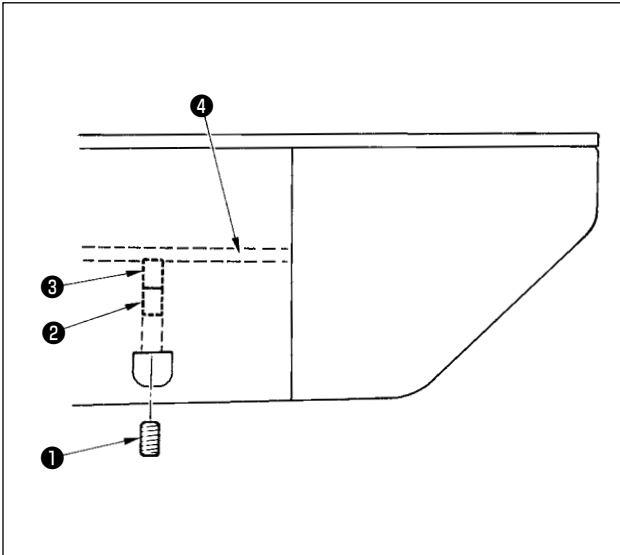

- 1) Loosen setscrew ❶ and remove setscrew ❶ .
- 2) When screwing in adjustment screw ❷ , the amount of oil of oil pipe, left ❹ can be reduced.
- 3) After the adjustment, screw in setscrew ❶ and fix it.

1. The state of standard delivery is the position where ❸ is lightly screwed in and returned by 4 turns.

2. When reducing the amount of oil, do not screw in the screw at once. Observe the state for approximately half a day at the position where ❸ is screwed in and returned by 2 turns. If reducing is excessive, worn-out of the hook will result.



7-8. Replacing the fuse

DANGER :



1. To avoid electrical shock hazards, turn OFF the power and open the control box cover after about five minutes have passed.
2. Open the control box cover after turning OFF the power without fail. Then, replace with a new fuse with the specified capacity.

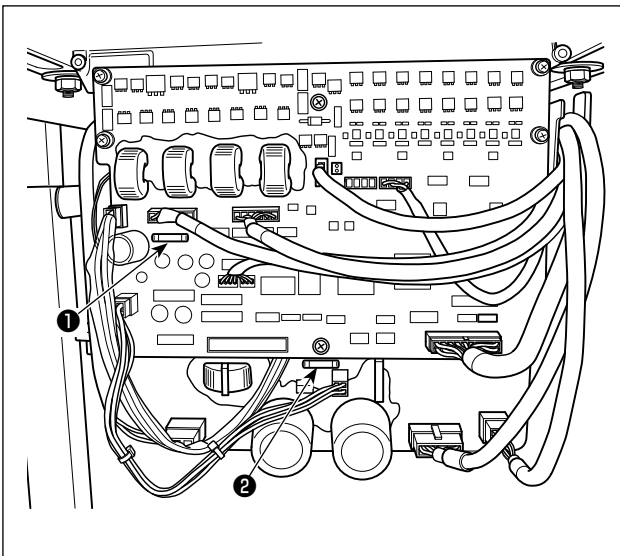

The machine uses the following two fuses :

MAIN PWB



- ❶ For pulse motor power supply protection
5A (time-lag fuse)

SDC PWB

- ❷ For control power supply protection
2A (fast-blow type fuse)

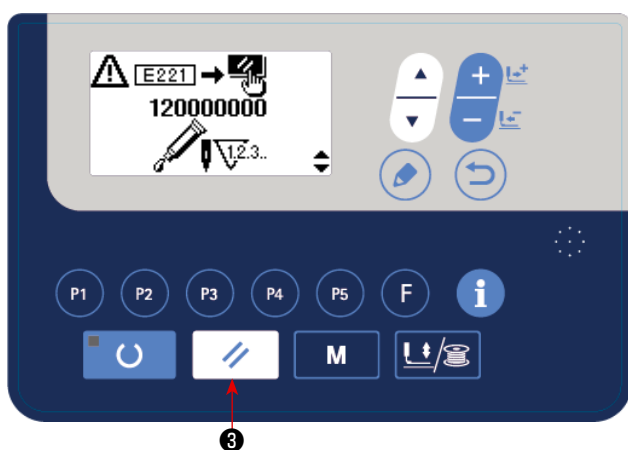
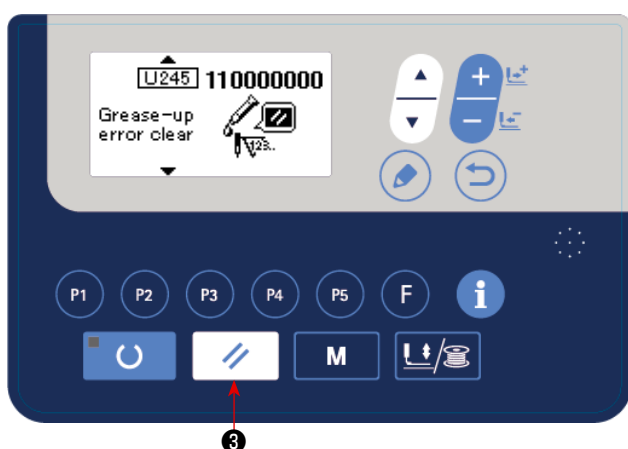
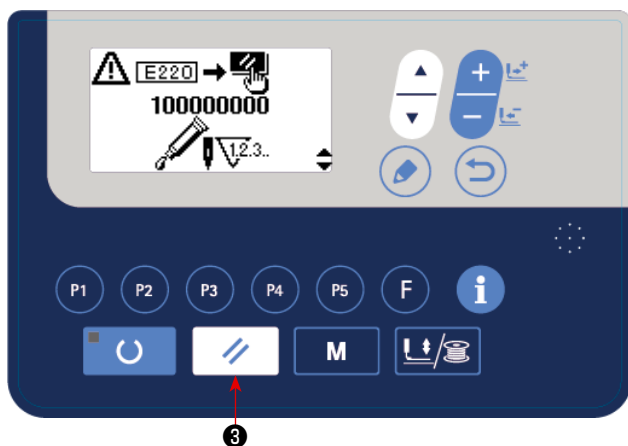
7-9. Replenishing the designated places with grease



When the sewing machine has been used for a certain number of times of sewing, error code No. E220 is displayed on the operation panel at the time of turning ON the power. This display informs the operator of the time of replenishing the designated places with grease. Be sure to replenish the places with the grease below. Then call the memory switch No. 245 and set it to "0" with the RESET key  ③ . Even after the display of the error No. E220, when the RESET key  ③ is pressed, the error is released, and the sewing machine can be continuously used. Afterwards, however, the error No. E220 is displayed every time the power is turned ON.

In addition, when the sewing machine is used further for a certain period of time after the display of error No. E220, the error No. E221 is displayed and the sewing machine fails to operate since the error cannot be released even when the RESET key  ③ is pressed.

When the error No. E221 is displayed, be sure to replenish the designated places below with grease. Then start up the memory switch and set No. 245 to "0" with the RESET key  ③ .



1. After replenishing the places with grease, the error No. E220 or No. E221 is displayed again unless the memory switch No. 245 is changed to "0".
2. Use grease tube (Part No. 40006323) supplied as accessories to replenish the designated places below with grease. If grease other than the designated one is replenished, damage of components will be caused.

**WARNING :**

Turn OFF the power before starting the work so as to prevent accidents caused by abrupt start of the sewing machine.

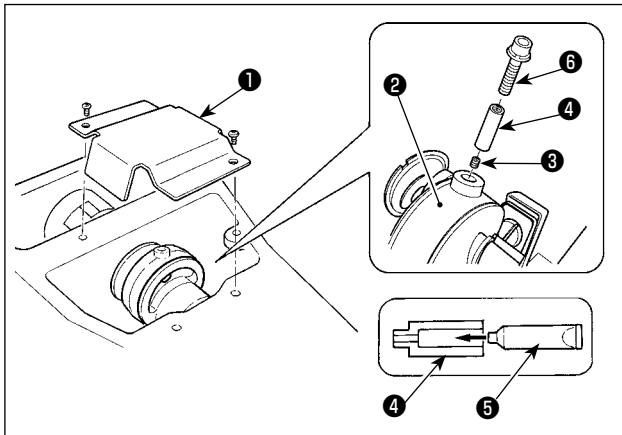
(1) Replenishing the eccentric cam section with grease

- 1) Open crank rod cover ① .
- 2) Remove setscrew ③ from the grease inlet cover located at periphery of crank rod ② .
- 3) Fill coupling ④ with grease through JUKI Grease A tube ⑤ .
- 4) Sink screw ⑥ supplied with the unit into the coupling to add the grease.
- 5) After adding the grease, securely tighten setscrew ③ which has been removed.

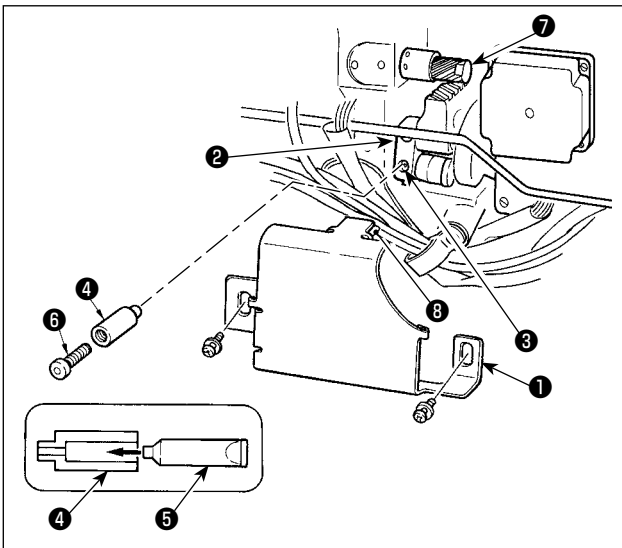
(2) Replenishing the oscillator pin section with grease

- 1) Tilt the machine head and remove the grease cover ① .
- 2) Remove setscrew ③ in oscillator gear ② .
- 3) Fill coupling ④ with grease through JUKI Grease A tube ⑤ .
- 4) Sink screw ⑥ supplied with the unit into the coupling to add the grease.
- 5) Securely tighten setscrew ③ which has been removed after replenishing with the grease.
- 6) Install grease cover ① at the location where felt ⑧ comes in contact with gear ⑦ .



**Do not strongly press felt ⑧ against gear ⑦ .
It can cause a moving failure.**

7-10. Disposal of batteries



The operation panel has a built-in battery in order to operate the clock even when the power is turned OFF.

Be sure to dispose of the battery following the local laws and regulations.

[How to remove the battery]

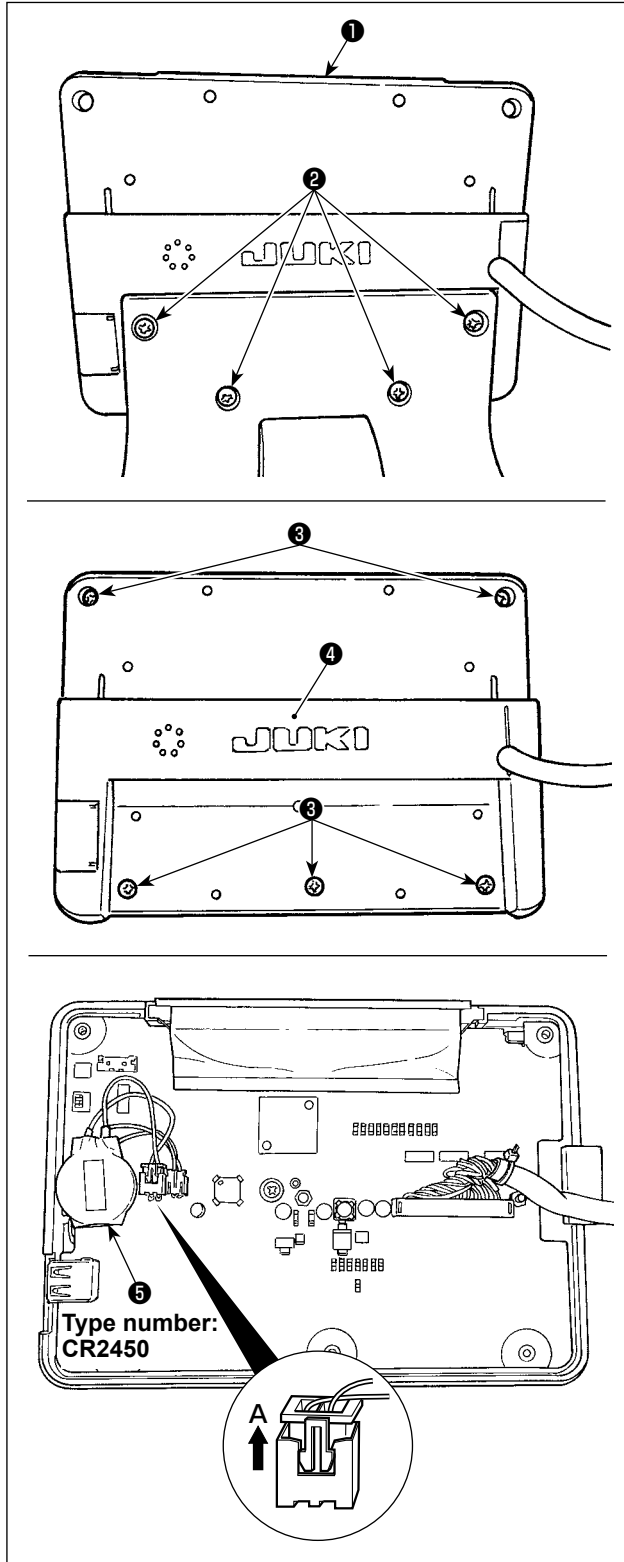

1) Remove operation panel ① from the fixing base. Detach screw ② from the fixing base.

2) Loosen screw ③ from the rear surface of the operation panel. Detach case ④ .

3) ⑤ is the battery for clock.
Type number: CR2450

4) Pull out the connector in the direction of A. Detach the whole main body of battery together with its case from the PCB. (The battery is secure on the PCB with double-faced adhesive tape.)

8. HOW TO USE THE MEMORY SWITCH

8-1. Method of changing memory switch data

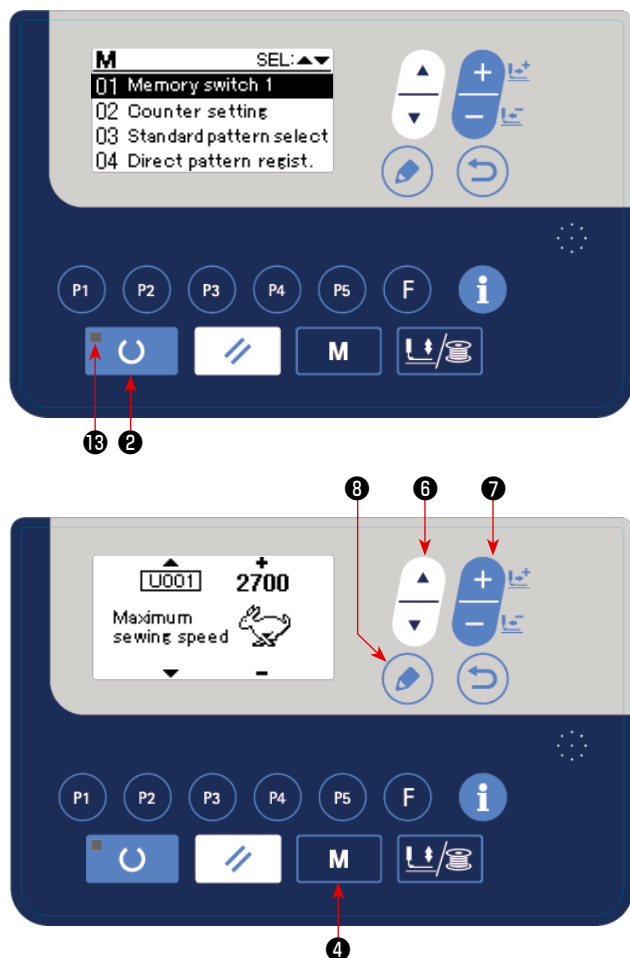

1) Set the mode to input mode.

Under the input mode where SET READY LED **13** goes out, change to the memory switch data is enabled.

If the current mode is the sewing mode, press READY key  **2** to change over the mode to the input mode.

2) Call memory switch data edit screen.

When MODE key  **4** is pressed, the mode screen (operator level) is displayed.

On this screen, select the memory switch data (level 1).

Press ITEM SELECT key  **6** to select "01 Memory switch 1".

When you press EDIT key  **8**, the memory switch data screen appears.

3) Select memory switch data to change.

Press ITEM SELECT key  **6** and select the data item which you desire to change.

4) Change data.

There are one data item to change the numerical value and the other data item to select the pictograph in the memory switch data.



































No. such as **U001** is attached to the data item to change the numerical value. Set value can be changed by increasing/decreasing the value with DATA CHANGE key  **7**.































No. such as **U019** is attached to the data item to select the pictograph. Pictograph can be selected with DATA CHANGE key  **7**.

































→ For the details of memory switch data, refer to "[I.8-2. List of the memory switch functions](#)" p.60.

8-2. List of the memory switch functions

Various operations of the sewing machine can be set by programming the memory switch.
The initial setting values at the time of shipment differ with models.

No.	Function	Setting range	State when delivered	Remarks
U001	Max. sewing speed (Speed can be set in a unit of 100 sti/min.) 	400 to 2700	2700	
U002	Sewing speed of 1st stitch (Speed can be set in a unit of 100 sti/min.) 	400 to 1500	400	
U003	Sewing speed of 2nd stitch (Speed can be set in a unit of 100 sti/min.) 	400 to 2700	900	
U004	Sewing speed of 3rd stitch (Speed can be set in a unit of 100 sti/min.) 	400 to 2700	2700	
U005	Sewing speed of 4th stitch (Speed can be set in a unit of 100 sti/min.) 	400 to 2700	2700	
U006	Sewing speed of 5th stitch (Speed can be set in a unit of 100 sti/min.) 	400 to 2700	2700	
U009	Changeover of tension releasing timing at the time of thread trimming 	-6 to 4	4	
U016	Disk floating timing at the beginning of sewing 	-10 to 2	-5	
U019	Selection of pedal  : Standard pedal  : Standard pedal (2-step stroke)  : Optional pedal  : Optional pedal (2-step stroke)	-		
U020	Selection of start pedal  : Standard pedal  : Optional pedal	-		
U024	Optional pedal 1 operation  : OFF when depressing pedal again  : OFF when detaching from pedal	-		
U025	Optional pedal 2 operation  : OFF when depressing pedal again  : OFF when detaching from pedal	-		
U026	Height of work clamp foot at the time of 2-step stroke 	50 to 90	70	Height is lowered when the set value is increased.
U030	Selection of base point of pattern enlargement/reduction  : Origin  : Sewing start point	-		
U031	Sewing machine operation can be stopped with panel key (clear key).  : Ineffective  : Panel RESET key  : External switch	-		
U032	Buzzer sound can be prohibited.  : Without buzzer sound  : Panel operation sound  : Panel operation sound + error sound	-		

No.	Function	Setting range	State when delivered	Remarks
U036	Feed timing is selected. When stitches are not well-tightened, set the value in “-” direction. 	- 8 to 16	12	Setting on excessive “-” side may cause needle breakage. Be careful when sewing heavy-weight material.
U037	State of work clamp foot after completion of sewing can be selected.  : Work clamp foot goes up after moving at the sewing start  : Work clamp foot goes up immediately after the end of sewing.  : Work clamp foot goes up by pedal operation after moving at the sewing start.	-		For LK-1903S/BR35, set to “  ”.
U039	Execution of origin retrieval every time after completion of sewing can be performed. (Except cycle stitching)  : Without origin retrieval  : With origin retrieval	-		
U040	Setting of origin retrieval in cycle stitching can be set.  : Without origin retrieval  : Every time 1 pattern is completed  : Every time 1 cycle is completed	-		
U041	State of work clamp foot when machine stopped by temporary stop command can be selected.  : Work clamp foot goes up.  : Work clamp foot goes up with work clamp foot switch.  : Lift of work clamp foot is prohibited.	-		
U042	Needle bar stop position is set.  : UP position  : Upper dead point	-		Needle bar rotates in the reverse direction after the UP position stop and stops when upper dead point stop is set.
U046	Thread trimming can be prohibited.  : Normal  : Thread trimming prohibited	-		
U048	Route of origin return by means of clear key can be selected.  : Straight line return  : Reverse return of pattern	-		This function is used when straight line return from the midway of pattern to the start of sewing is not possible.
U049	Bobbin winding speed can be set.	800 to 2000	1600	Max. speed limitation has priority.
U051	Wiper operation method can be selected.  : Without wiper at the time of thread trimming on the way  : With wiper at the time of thread trimming on the way ①  : With wiper at the time of thread trimming on the way	-		① : Without return of the last wiper ② : With return of the last wiper

No.	Function	Setting range	State when delivered	Remarks
U055	Effective/ineffective of tie stitching for button sewing can be selected.  : Tie stitching effective  : Tie stitching ineffective	-		
U064	The dimension input increment can be selected.  % : In percentage (%)  mm : In dimension	-		
U065	Y origin shift method can be selected.  ±0 : Standard  -5 : Offset by -5 mm (for 1904 work clamp)	-		
U069	Common/individual of the 2-step stroke height is selected.  : Common  : Individual (the height can be set with respect to each direct pattern)	-		
U070	Display/hide of the travel of the last stitch can be set.  : Hide  : Display	-		
U074	The fan operation can be set.  : Energy saving mode  : Constantly operates	-		
U077	Used for selecting enable / disable of the count-completion display for the sewing counter  : Count-completion display is disabled  : Count-completion display is enabled	-		
U080	Audio output setting  ALL All audio guidance ON  : Panel operation guidance only  : All audio guidance OFF	-		
U081	Selection of language for audio function  English  Chinese	-		
U239	Choice of language. With this switch, the language to be displayed on the panel is selected. * The number of selectable languages differs with the type of sewing machine shipped English : Not yet selected (display in English) English : English  中文 简体字 : Chinese (simplified characters)  中文 繁體字 : Chinese (traditional Chinese) Español : Spanish Italiano : Italian Français : French Deutsch : German Português : Portuguese Türkçe : Turkish Tiếng Việt : Vietnamese Indonesia : Indonesian Русский : Russian বাংলা : Bengali  ខ្មែរ : Khmer	-	Not yet selected (display in English)	
U245	Grease-up needle. 	0 to 12000000 (Stitches) (Cannot be set)		The number of stitches can be cleared by keeping the RESET key held pressed.

9. OTHERS

9-1. Table of the standard pattern specifications

No.	Lengthwise	Crosswise	Number of stitches	Pattern	S, H
1	2.0	16	42	Large size bartacking	*
2	2.0	10	42	Large size bartacking	*
3	2.5	16	42	Large size bartacking	*
4	3.0	24	42	Large size bartacking	
5	2.0	10	28	Large size bartacking	*
6	2.5	16	28	Large size bartacking	*
7	2.0	10	36	Large size bartacking	*
8	2.5	16	36	Large size bartacking	*
9	3.0	24	56	Large size bartacking	
10	3.0	24	64	Large size bartacking	
11	2.5	6	21	Small size bartacking (eyelet)	*
12	2.5	6	28	Small size bartacking (eyelet)	*
13	2.5	6	36	Small size bartacking (eyelet)	*
14	2.0	8	14	Knit goods bartacking	*
15	2.0	8	21	Knit goods bartacking	*
16	2.0	8	28	Knit goods bartacking	*
17	0	10	21	Straight line bartacking	*
18	0	10	28	Straight line bartacking	*
19	0	25	28	Straight line bartacking	
20	0	25	36	Straight line bartacking	
21	0	25	41	Straight line bartacking	
22	0	35	44	Straight line bartacking	
23	20	4.0	28	Lengthwise bartacking	
24	20	4.0	36	Lengthwise bartacking	
25	20	4.0	42	Lengthwise bartacking	
26	20	4.0	56	Lengthwise bartacking	
27	20	0	18	Lengthwise straight line bartacking	
28	10	0	21	Lengthwise straight line bartacking	
29	20	0	21	Lengthwise straight line bartacking	
30	20	0	28	Lengthwise straight line bartacking	
38	2.0	8	28	Knit goods bartacking	*

In the condition of delivery from the factory, the pattern sewing with * marks can be made.

When using the standard patterns other than the patterns with * marks, refer to **"I.6-8. Setting enable/disable of standard pattern invoking"** p.43 described in the item of the how to use the memory switch.

9-2. Table of the standard patterns

	No.	Stitch diagram	Number of stitches	Sewing size (mm)		(Note 2) No. of work clamp foot	
				Length-wise	Cross-wise		
Large size bartacking	1		42	2.0	16	1	
						2	
						3	
		2		42	2.0	10	1
			2				
			3				
		3 ※		42	2.5	16	1
			4				
		4 ※		42	3.0	24	6
			7				
	5		28	2.0	10	1	
		2					
		3					
	6 ※		28	2.5	16	1	
		4					
	7		36	2.0	10	1	
		2					
		3					
	8 ※		36	2.5	16	1	
		4					
	9 ※		56	3.0	24	6	
		7					
	10 ※		64	3.0	24	6	
		7					
Small size bartacking	11		21	2.5	6	8	
	12		28	2.5	6		
	13		36	2.5	6		
Knit goods bartacking	14		14	2.0	8	5	
	15		21	2.0	8		
	16		28	2.0	8		
Straight line bartacking	17		21	0	10	1	
						2	
						3	
		18		28	0	10	1
			2				
			3				
		19		19	0	25	6
			7				
		20		20	0	25	6
			7				
	21		21	0	25	6	
		7					
	22		44	0	35	(Note3)	
Lengthwise bartacking	23		28	20	4.0	9	
						10	
	24		36	20	4.0	9	
						10	
	25		42	20	4.0	9	
						10	
26		56	20	4.0	9		
					10		
Lengthwise straight line bartacking	27		18	20	0	11	
	28		21	10	0		
	29						
30		28	20	0			

- (Note) 1. Sewing size shows the dimensions when the scale rate is 100%.
 2. Refer the No. of work clamp foot to the separate table of work clamp foot.
 3. For No. 22, process the work clamp foot blank for use.
 4. Use the patterns with ※ marks for sewing denim.

	No.	Stitch diagram	Number of stitches	Sewing size (mm)		(Note 2) No. of work clamp foot
				Length-wise	Cross-wise	
Semilunar bartacking	31		52	7	10	13
	32		63	7	12	13
	33		24	6	10	13
	34		31	6	12	13
	35		48	10	7	14
	36		48	10	7	14
Large size bartacking	37		90	3	24	6
			7			
Knit goods bartacking	38		28	2	8	5
Round bartacking	39		28	ø12		16
	40		48			

	No.	Stitch diagram	Number of stitches	Sewing size (mm)		(Note 2) No. of work clamp foot	
				Length-wise	Cross-wise		
Lengthwise bartacking	41		29	20	2.5	12	
	42		39	25	2.5	12	
	43		45	25	2.5	12	
	44		58	30	2.5	12	
	45		75	30	2.5	12	
	46		42	30	2.5	12	
	Radial bartacking	47		91	ø8		15
		48		99			
		49		148			
		50		164			

Caution
Pattern Nos. 41 to 46 are for the optional work clamp foot No. 12. The origin of the patterns is different by 5 mm up and down from that of lengthwise bartacking pattern Nos. 23 to 26.

9-3. Table of the work clamp foot

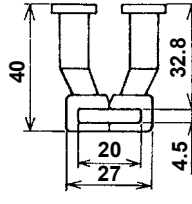
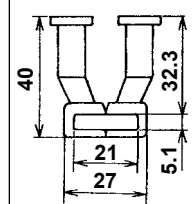
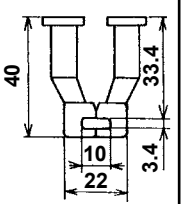
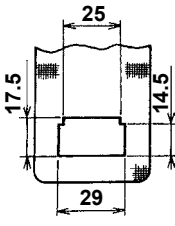
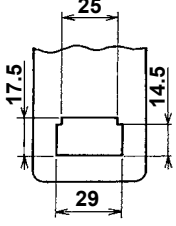
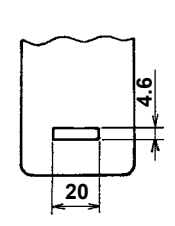
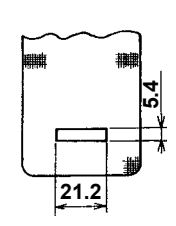
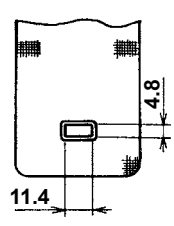
	1	2	3	4	5
Work clamp foot	13518659 (asm.)			13548557 (asm.)	13542964 (asm.)
					
Feed plate	14116107	14116404	14116800	14116305	14116206
	(With knurl)	(Without knurl)	(Without knurl)	(With knurl)	(With knurl)
					
Sewingspecification	S	F	F	H / W	M
※ Finger guard	13533104				
Remarks	Standard accessory for S (standard) type machine head.	Optional		Optional	Optional

※ Install a finger guard suitable for each work clamp foot when replacing the work clamp foot.

	6	7	8	9	10	11
Work clamp foot	13548151 (asm.)		13542451 (asm.)	13571955 (asm.)		13561360 (asm.)
Feed plate	13548003 (With knurl)	13554803 (With knurl)	14116602 (With knurl)	14116503 (Without knurl)	14116909 (Without knurl)	14116701 (Without knurl)
Sewing specification	S	H	S	F	F	F
※ Finger guard	13548300		13533104	13573407		
Remarks	Optional	Standard accessory for H type (Heavy-weight material) machine head.	Optional	Optional		Optional

	12	13	14	15	16
Work clamp foot	14137509 (right) 14137608 (left)	40021871 (right) 40021872 (left)	40021874 (right) 40021875 (left)	40021877 (right) 40021878 (left)	40021880 (right) 40021881 (left)
Feed plate	14137707 (Without knurl)	40021873 (With knurl)	40021876 (With knurl)	40021879 (With knurl)	40021882 (With knurl)
Sewing specification	F	S	S	S	S
※ Finger guard	14135305	13533104			
Remarks	Optional	Optional	Optional	Optional	Optional

※ Install a finger guard suitable for each work clamp foot when replacing the work clamp foot.

9-4. Installing the foot pedal switch (optional)



DANGER :

To prevent personal injuries caused by electric shock hazards or abrupt start of the sewing machine, carry out the work after turning OFF the power switch and a lapse of 5 minutes or more. To prevent accidents caused by unaccustomed work or electric shock, request the electric expert or engineer of our dealers when adjusting the electrical components.

The hand switch is provided on the standard type machine.

To use the optional foot pedal switch (part number: GPK570010B0), connect it in the procedure described below. When installing the foot pedal switch, the foot pedal switch junction cable asm. (part number: M90135900A0) is also required. Refer to "[I.9-8. Table of the optional parts](#)" p.77.

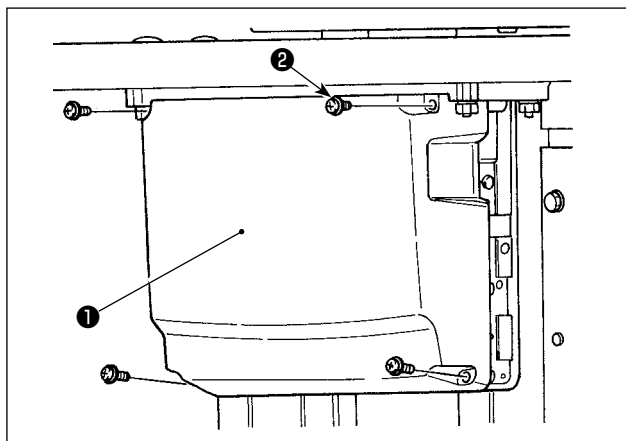

- 1) Loosen the four setscrews **2** in the control box to remove cover **1**.

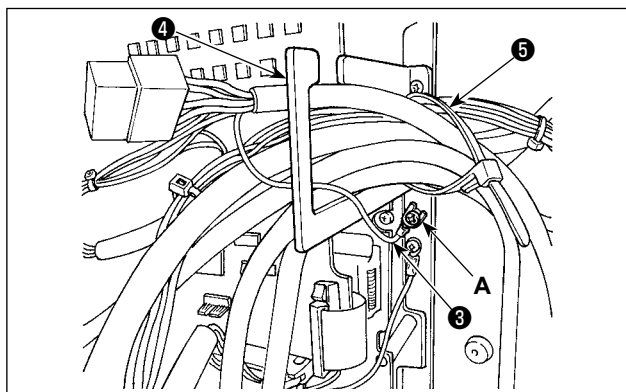

- 2) Fix earthing wire **3** of the foot pedal switch at location **A** of the control box.

Caution Pass the earthing wire **3** through cord exit plate **4**. If not, it can be caught under the cover when closing it.

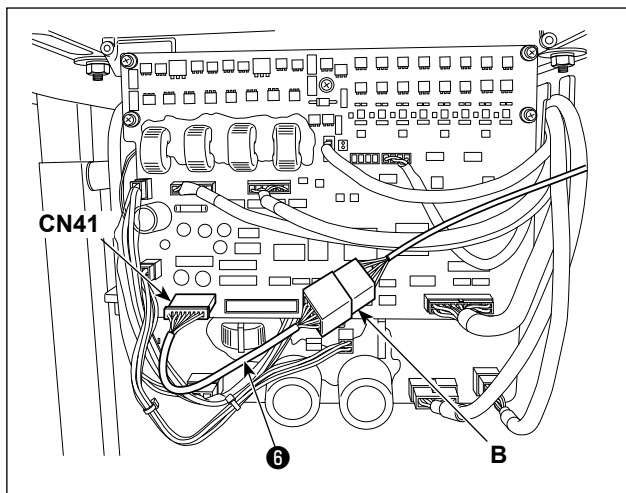

- 3) Connect foot pedal switch junction cable **6** to the foot pedal switch cable (**B**) and connect the opposite side of the junction cable to CN41 connector on the PWB.













- 4) Loosen cable clip band **5**. Fix the foot pedal switch cables (excluding earthing wire **3**) by means of cable clip band **5** together with other related cables.









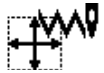

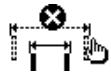
DANGER :



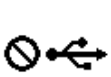



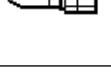



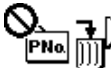

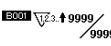





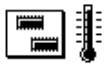
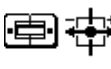

It is very important to carefully connect the cables to the correct connectors on the PWB. Wrong connection poses a great risk.

9-5. Error list

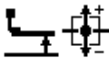
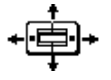







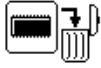
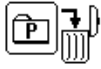
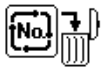

Error code	Indication	Description of error	Corrective measure	Remarks
E007		Machine lock error The main shaft of the sewing machine does not rotate due to some troubles.	Turn OFF the power switch and remove the cause of troubles.	
E010		Pattern No. error Back-uped pattern No. has not been registered in the data ROM, or it is set to readout inoperative. Pattern No. is set to "0".	Press the reset key and check the pattern No. Check the contents of memory switch No. 201.	
E011		External media not inserted USB thumb drive is not inserted.	Re-operation is enabled after resetting.	
E012		Read error Data cannot be read from the USB thumb drive.	Re-operation is enabled after resetting.	
E013		Write error Data cannot be written on the USB thumb drive.	Re-operation is enabled after resetting.	
E014		Write-protect USB thumb drive is write-protected.	Re-operation is enabled after resetting.	
E015		Format error USB thumb drive cannot be formatted.	Re-operation is enabled after resetting.	
E016		External media capacity over Memory capacity of the USB thumb drive to write pattern data is not sufficient.	Re-operation is enabled after resetting.	
E017		Machine memory capacity over Memory capacity of the sewing machine to write pattern data is not sufficient.	Re-operation is enabled after resetting.	
E019		File size over The pattern data to be read from the USB thumb drive is too large. (Max.: Approximately 20000 stitches)	Re-operation is enabled after resetting.	
E022		File No. error There is no designated file in the external media.	Possible to recover by reset.	Previous screen
E024		Pattern data size over The pattern data to be written on the sewing machine memory is too large. (Max.: Approximately 20000 stitches)	Re-operation is enabled after resetting.	
E030		Needle bar position error Needle bar is not in the specified position.	Turn the hand pulley to return the needle bar to its specified position.	
E040		Travel limit error The dimensions of the sewing pattern exceed the travel limit range	Press the RESET key. Then, check the X/Y scale and dimensions of the pattern.	Press the RESET key. Then, check the X/Y scale and dimensions of the pattern.

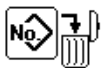





Error code	Indication	Description of error	Corrective measure	Remarks
E043		Enlargement error The sewing pitch is beyond 10 mm.	Press the reset key and check the pattern and X/Y scale rate.	
E045		Pattern data error The pattern data cannot be adopted.	Re-operation is enabled after resetting.	
E050		Temporary stop Temporary stop by operating the reset key while the sewing machine is running. (Refer to memory switch No. 31.)	Re-start or return-to-origin after thread trimming by means of the reset key (For the details, refer to the item "I.6-4. How to use the temporary stop" p.37.)	
E061		Memory switch data error Memory switch data is broken or revision is old.	Re-operation is enabled after resetting.	
E063	TYPE 	Machine head identification error The type of machine head and the type of control box do not match.	Turn the power OFF and contact JUKI or your distributor.	
E204		Connection alert for the USB thumb drive which is used for sewing Sewing has been carried out by 10 or more times with the USB thumb drive inserted in the USB port.	Re-operation is enabled after resetting.	
E220	100000000 	Grease replenishing time information Information as to the time of replenishing the designated places with grease Refer to "I.7-9. Replenishing the designated places with grease" p.56.	Replenish the designated places with grease and set memory switch No. 245 to "0" with the RESET key. Error can be released with the RESET key when immediate replenishing with grease cannot be performed during sewing operation.	
E221	120000000 	Grease replenishing warning error Sewing machine has stopped since the time of replenishing the designated places with grease has come. Refer to "I.7-9. Replenishing the designated places with grease" p.56.	Immediately perform replenishing with grease and set memory switch No. 245 to "0" with the RESET key.	
E302		Head tilt error Head tilt detection switch is turned OFF.	The sewing machine cannot be operated with the head tilted. Return the sewing machine head to its proper position.	
E303		Z phase detection error Detection of the upper dead point of the sewing machine cannot be performed.	Turn OFF the power switch. Check whether the pin of the SDC board CN15 has come off or has loosened.	
E305		Thread trimmer position error The thread trimmer is not in the proper position.	Turn OFF the power switch and check whether CN72 has come off or has loosened.	

Error code	Indication	Description of error	Corrective measure	Remarks
E405		Prohibition of deletion of direct patterns The direct pattern is set in the cycle sewing data.	Re-operation is enabled after resetting.	
E408		Password reset error Wrong password has been entered.	Re-operation is enabled after resetting.	
E430		Counter set-value is reached The set value of the counter is reached. * For the type of counter and the counter value displayed depends on the predetermined counter.	Re-operation is enabled after resetting.	
E730		Encoder trouble A Encoder A or B phase cannot be detected.	Turn OFF the power switch. Check whether the pin CN15 has come off or has loosened.	
E731		Encoder trouble B Encoder U, V or W phase cannot be detected.	Turn OFF the power switch. Check whether the pin CN15 has come off or has loosened.	
E733		Reverse rotation of motor The motor is reversing.	Turn OFF the power switch and check whether coupling of the main motor is loose.	
E811		Overvoltage error Power source voltage is beyond the specified value.	Check the power supply voltage.	
E813		Low voltage error Power source voltage is short.	Check the power supply voltage.	
E901		Motor driver trouble Error from the motor driver is detected.	Turn OFF the power switch and turn ON the power switch again after some time.	
E903		Stepping motor power supply trouble Power source of the stepping motor is not output.	Turn OFF the power switch and check F1 fuse of SDC board.	
E904		Solenoid power supply trouble Power source of the solenoid is not output.	Turn OFF the power switch and check F2 fuse of SDC board.	
E905		SDC board overheat Overheat of SDC board	Turn OFF the power switch and turn ON the power switch again after some time.	
E907		X origin retrieval error X origin sensor does not change.	Turn OFF the power switch and check whether CN42 and/or CN53 of the MAIN board are disconnected or loose.	

Error code	Indication	Description of error	Corrective measure	Remarks
E908		Y origin retrieval error Y origin sensor does not change.	Turn OFF the power switch and check whether CN43 and/or CN54 of the MAIN board are disconnected or loose.	
E910		Work clamp foot origin retrieval error Work clamp foot origin sensor does not change.	Turn OFF the power switch and check whether CN71 of INT board or CN44 of MAIN board is disconnected or loose.	
E914		Feed trouble error Timing lag between feed and main shaft has occurred.	Turn OFF the power switch and check whether coupling of the main motor is loose.	
E915		Communication error between panel and MAIN Communication between the panel and MAIN cannot be performed.	Turn OFF the power switch and check whether CN34 of MAIN board is disconnected or loose.	
E916		Communication error between MAIN and SDC Communication between MAIN and SDC cannot be performed.	Turn OFF the power switch and check whether CN32 of MAIN board or CN15 of SDC board is disconnected or loose.	
E918		MAIN board overheat Overheat of MAIN board	Turn OFF the power switch and turn ON the power switch again after some time.	
E943		MAIN memory write-in trouble Memory write-in of MAIN board cannot be performed.	Turn OFF the power switch and check the insertion of ROM of U022 of MAIN board.	
E946		INT memory write-in trouble Memory write-in of the head board cannot be performed.	Turn OFF the power switch and check whether CN30 of MAIN board is disconnected or loose.	
-		Power supply fault, connector disconnection The supply voltage specification is not correct. The connector has dropped off.	Turn OFF the power switch. Check the supply voltage, and check the CN3 of the FLT board and CN13 of the SDC board is disconnected or loose.	

9-6. Message list

Message No.	Display	Display message	Description
M520		Erase is performed. OK ?	Erase confirmation of Users' pattern
M521		Erase is performed. OK ?	When deletion of the direct pattern is checked
M522		Erase is performed. OK ?	Erase confirmation cycle pattern
M523		Pattern data is not stored in memory. Erase is OK ?	Erase confirmation of backup data
M524		Erase is performed. OK ?	When deletion (of pattern data) is checked on the communication screen
M525		Erase is performed. OK ?	When deletion (of machine data) is checked on the communication screen
M528		Overwriting is performed. OK ?	Overwriting confirmation of users' pattern
M529		Overwriting is performed. OK ?	Overwriting confirmation of media
M530		Overwriting is performed. OK ?	When overwrite is checked on the communication screen (Panel + pattern data)
M531		Overwriting is performed. OK ?	When overwrite is checked on the communication screen (Media+ pattern data)
M533		Overwriting is performed. OK ?	When overwrite is checked on the communication screen (Panel + machine data)
M537		Deleting is performed. OK ?	When deletion of (thread tension) data is checked on the communication screen
M542		Formatting is performed. OK ?	Format confirmation

Message No.	Display	Display message	Description
M547		Overwriting cannot be performed since data exists.	Overwrite is disabled (panel)
M548		Overwriting cannot be performed since data exists.	Overwrite is disabled (media)
M581		Registration is canceled.	Registration of a direct pattern
M582		Copy is cancelled.	Exited from the pattern data screen without copying
M583		Copy is cancelled.	Exited from the direct pattern screen without copying
M584		Copy is cancelled.	Exited from the cycle pattern screen without copying

9-7. Troubles and corrective measures (sewing conditions)

Trouble	Cause	Corrective measures	Page
1. The needle thread slips off at the start of bar-tacking.	① Stitches are slipped at the start.	○ Adjust the clearance between the needle and the shuttle to 0.05 to 0.1 mm.	52
	② The needle thread remaining on the needle after thread trimming is too short.	○ Set soft-start sewing at the start of bartacking. ○ Correct the thread tension release timing of the thread tension controller No. 2.	59
	③ The bobbin thread is too short.	○ Increase the tension of the thread take-up spring, or decrease the tension of the thread tension controller No. 1. ○ Retard the tension disk closing timing.	17
	④ Needle thread tension at 1st stitch is too high.	○ Decrease the tension of the bobbin thread. ○ Increase the clearance between the needle hole guide and the counter knife.	60 16
	⑤ Pitch at 1st stitch is too small.	○ Decrease the tension at 1st stitch. ○ Decrease the number of rotation at 1st stitch at the sewing start. (Extent of 600 to 1,000 sti/min) ○ Make the pitch at 1st stitch longer.	53
2. Thread often breaks or synthetic fiber thread splits finely.	① The shuttle or the driver has scratches.	○ Take it out and remove the scratches using a fine whetstone or buff.	53
	② The needle hole guide has scratches.	○ Buff or replace it.	
	③ The needle strikes the work clamp foot.	○ Correct the position of the work clamp foot.	16
	④ Fibrous dust is in the groove of the shuttle race.	○ Take out the shuttle and remove the fibrous dust from the shuttle race.	
	⑤ The needle thread tension is too high.	○ Reduce the needle thread tension.	
	⑥ The tension of the thread take-up spring is too high.	○ Reduce the tension.	17
	⑦ The synthetic fiber thread melts due to heat generated on the needle.	○ Use silicone oil.	15
3. The needle often breaks.	① The needle is bent.	○ Replace the bent needle.	14
	② The needle hits the work clamp foot.	○ Correct the position of the work clamp foot.	53
	③ The needle is too thin for the material.	○ Replace it with a thicker needle according to the material.	52
	④ The driver excessively bends the needle.	○ Correctly position the needle and the shuttle.	
	⑤ Needle thread is stepped on by the work clamp foot at the start of sewing. (Needle bend)	○ Widen the distance between the needle and the wiper. (23 to 25 mm)	54
4. Threads are not trimmed. (Bobbin thread only)	① The counter knife is dull.	○ Replace the counter knife.	53
	② The difference in level between the needle hole guide and the counter knife is not enough.	○ Increase the bend of the counter knife.	
	③ The moving knife has been improperly positioned.	○ Correct the position of the moving knife.	52
	④ The last stitch is skipped.	○ Correct the timing between the needle and the shuttle.	
	⑤ Bobbin thread tension is too low.	○ Increase the bobbin thread tension.	

Trouble	Cause	Corrective measures	Page
5. Stitch skipping often occurs.	① The motions of the needle and shuttle are not properly synchronized.	○ Correct the positions of the needle and shuttle.	52
	② The clearance between the needle and shuttle is too large.	○ Correct the positions of the needle and shuttle.	52
	③ The needle is bent.	○ Replace the bent needle.	14
	④ The driver excessively bends the needle.	○ Correctly position the driver.	52
6. The needle thread comes out on the wrong side of the material.	① The needle thread tension is not high enough.	○ Increase the needle thread tension.	16
	② The tension release mechanism fails to work properly.	○ Check whether or not the tension disc No. 2 is released during bar-tracking.	16
	③ The needle thread after thread trimming is too long.	○ Increase the tension of the thread tension controller No. 1.	
	④ Number of stitches is too few.	○ Use the lower plate, the hole of which is larger than the presser.	
	⑤ When sewing length is short (End of needle thread protrudes on the wrong side of sewing product.)	○ Change of the sewing pattern.	
7. Threads break at time of thread trimming.	① The moving knife has been improperly position.	○ Correct the position of the moving knife.	53
8. Uneven length of the needle thread	① The tension of thread take-up spring is too low.	○ Increase the tension of the thread take-up spring.	
9. The length of needle thread does not become short.	① The tension of thread tension controller No. 1 is too low.	○ Increase the tension of thread tension controller No. 1.	
	② The tension of thread take-up spring is too high.	○ Decrease the tension of thread take-up spring.	
	③ The tension of thread take-up spring is too low and motion is unstable.	○ Increase the tension of thread take-up spring and lengthen the stroke as well.	
10. The knotting section of bobbin thread at 2nd stitch at the sewing start appears on the right side.	① Idling of bobbin is large.	○ Adjust the position of the moving knife.	
	② The bobbin thread tension is too low.	○ Increase the bobbin thread tension.	

9-8. Table of the optional parts

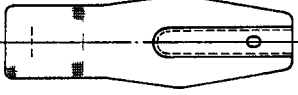
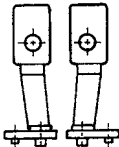
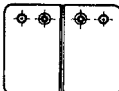
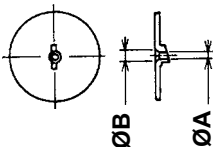
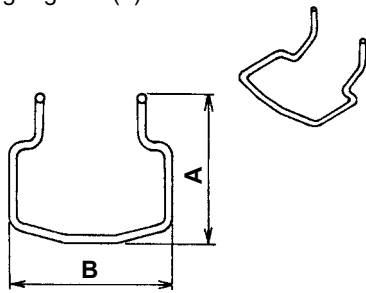
Name of Parts	Type	Part No.	Remarks
Feed plate blank  t = 1.2	Without knurl / processed Sewing area lengthwise 20 X crosswise 40	14120109	
	With knurl / processed Sewing area lengthwise 20 X crosswise 40	14120307	
	Without knurl / stainless steel Sewing area lengthwise 20 X crosswise 40	14120505	t = 0.5
	Without knurl / processed Sewing area lengthwise 30 X crosswise 40	40021855	
	Without knurl / without processing Sewing area lengthwise 30 X crosswise 40	40021856	
	Without knurl / stainless steel Sewing area lengthwise 30 X crosswise 40	40021857	t = 0.5
	With knurl / processed Sewing area lengthwise 30 X crosswise 40	40021858	
	With knurl / without processing Sewing area lengthwise 30 X crosswise 40	40021859	
	Work clamp foot face plate (asm.) 		14121263
Presser blank  t = 3.2	With knurl / Processed (right) Sewing area lengthwise 20 X crosswise 40	14121701	
	With knurl / Processed (Left) Sewing area lengthwise 20 X crosswise 40	14121800	
	With knurl / Processed (right) Sewing area lengthwise 30 X crosswise 40	40021851	
	With knurl / Processed (Left) Sewing area lengthwise 30 X crosswise 40	40021852	
	With knurl / without processing (right) Sewing area lengthwise 30 X crosswise 40	40021853	
	With knurl / without processing (Left) Sewing area lengthwise 30 X crosswise 40	40021854	
	Needle hole guide	A=1.6 B=2.6 With relief slit	B2426280000
	A=1.6 B=2.0 Without relief slit	D2426282C00	F and M types
	A=2.3 B=4.0 Without relief slit	14109607	H and W types
	A=2.7 B=3.7 Without relief slit	D2426MMCK00	For extra heavy-weight material
	Finger guard (1)	A=56.5 B=64	13533104
	A=59 B=74	13548300	For large size bartacking

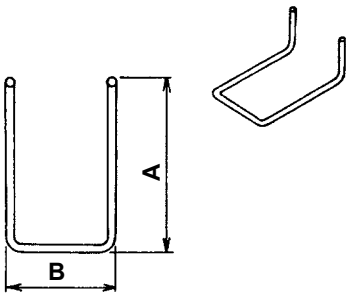
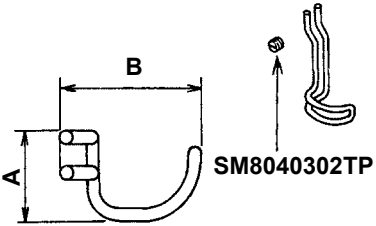
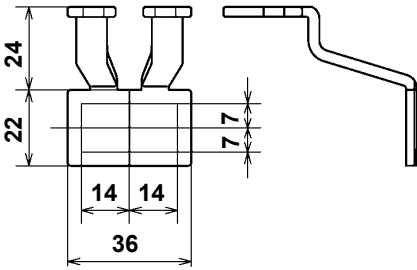
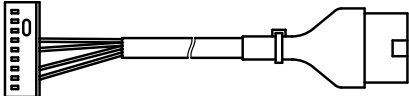
Name of Parts	Type	Part No.	Remarks
Finger guard (2) 	A=66.5 B=43	13573407	For lengthwise bartacking
Finger guard (3) 	A=21.5 B=35.5	14120000	For specially ordered work clamp
Work clamp foot blank 	With knurl / processed (right)	40021869	
	With knurl / processed (left)	40021870	
PK57 changing cable asm. 		M90135900A0	

II. EXPLANATION OF THE LK-1903S, COMPUTER-CONTROLLED HIGH-SPEED LOCKSTITCH BUTTON SEWING MACHINE

1. SPECIFICATIONS

Different specifications from those of the LK-1900S only are described.

1	Max. sewing speed	2,700 sti/min
2	Needle	DPx17 #14
3	Lift of the work clamp foot	Max. 13mm
4	Number of standard patterns	50 patterns

2. PREPARATION OF THE SEWING MACHINE

2-1. Installation of the sewing machine and preparation of the operation



DANGER :

Be sure to perform the work with two persons or more when moving the sewing machine.

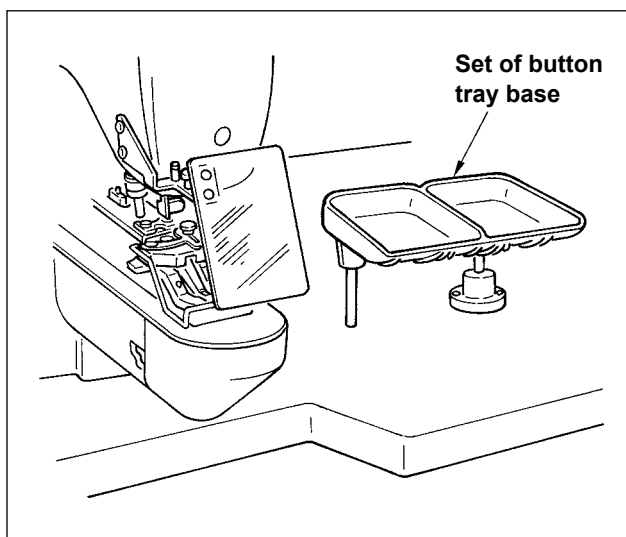

- 1) Installation of the sewing machine head and the control box is the same as that of the LK-1900S. Refer to the instruction manual for the LK-1900S.
- 2) Install a set of the button tray base to a convenient place for the work as the set is included in the accessories.
- 3) The way of operation is the same as that of the LK-1900S.

2-2. Needle and thread

Needle	Needle thread	Bobbin thread
DPx17 #14	#60	#80
	#60	#60
	#50	#60
	#40	#60

Needle and thread will vary in accordance with the sewing conditions. When using the needle and the thread, select them referring to the left table. Cotton thread and polyester spun thread are recommended.

2-3. Various sewing modes

(1) List of sewing patterns

Number of threads and standard sewing size of X and Y are as shown in the following list.

< Sewing program list >

Pattern No.	Stitch shape	Number of threads (thread)	Standard sewing size X (mm)	Standard sewing size Y (mm)	Pattern No.	Stitch shape	Number of threads (thread)	Standard sewing size X (mm)	Standard sewing size Y (mm)
1 • 34		6-6	3.4	3.4	18 • 44		6	3.4	0
2 • 35		8-8			19 • 45		8		
3		10-10			20		10		
4		12-12			21		12		
5 • 36		6-6			22		16		
6 • 37		8-8			23 • 46		6	0	3.4
7		10-10			24		10		
8		12-12			25		12		
9 • 38		6-6			26 • 47		6-6	3.4	3.4
10 • 39		8-8			27		10-10		
11		10-10			28 • 48		6-6		
12 • 40		6-6			29		10-10		
13 • 41		8-8			30 • 49		5-5-5	3.0	2.5
14		10-10			31		8-8-8		
15 • 42		6-6			32 • 50		5-5-5		
16 • 43		8-8			33		8-8-8		
17		10-10							

* The standard sewing sizes of X and Y are when the enlargement / reduction rate is 100%.
Use the pattern No. 34 to No.50 when the button hole is small (ø1.5 mm or less).

(2) Selection of the sewing pattern and the sewing width

- Selection of the sewing pattern is the same as that of the LK-1900S.
- When the distance between holes of the button used does not fit the standard sewing width of the sewing pattern No., adjust the sewing width by enlarging/reducing the sewing width.
The way of enlarging/reducing is the same as that of the LK-1900S. Refer to the table given below for the scale for enlargement/reduction in terms of the sewing width.
- After changing the sewing pattern No. and the sewing width, make sure of the needle entry point.
As for the way of confirmation, refer to the "I.5-4. Checking the contour of a sewing pattern" p.21 in the instruction manual for the LK-1900S.

◎ Table of XY scale in terms of the sewing width

X*Y (mm)	2.4	2.6	2.8	3.0	3.2	3.4	3.6	4.0	4.3	4.5	4.7	5.2	5.6	6.0	6.2	6.4
%	71	76	82	88	94	100	106	118	126	132	138	153	165	176	182	188

3. ADJUSTMENT OF THE SEWING MACHINE

3-1. Position of the button clamp jaw lever

WARNING :

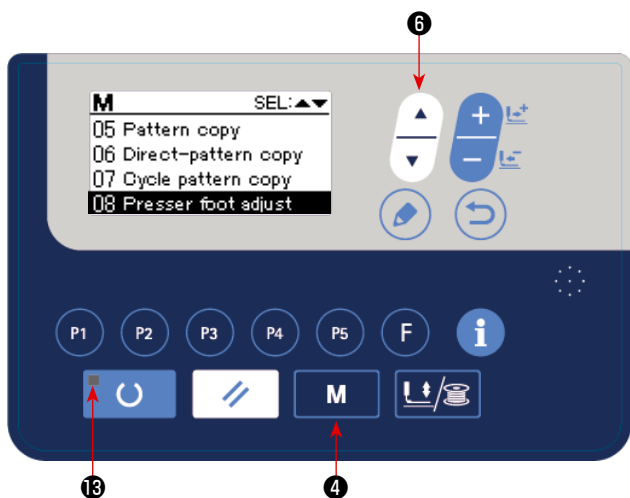
 When change of the shape of button, change of the sewing pattern or enlargement/reduction of the sewing width is performed, make sure the needle entry point. If the needle extends outside the button hole or the sewing pattern extends outside the button clamp unit, the needle interferes with the button hole or the button clamp unit, resulting in the danger of the needle breakage or the like.

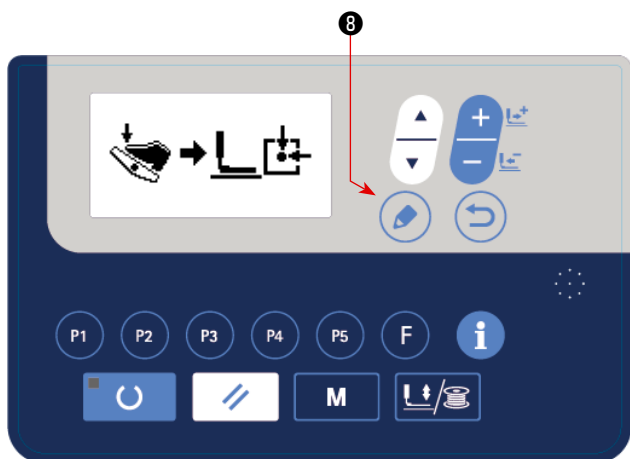

- 1) Press MODE key **M** **4** in the state where sewing LED **13** goes out on the operation panel.
- 2) Put "08 Presser foot adjust" in the selected state with ITEM SELECT key  **6**.

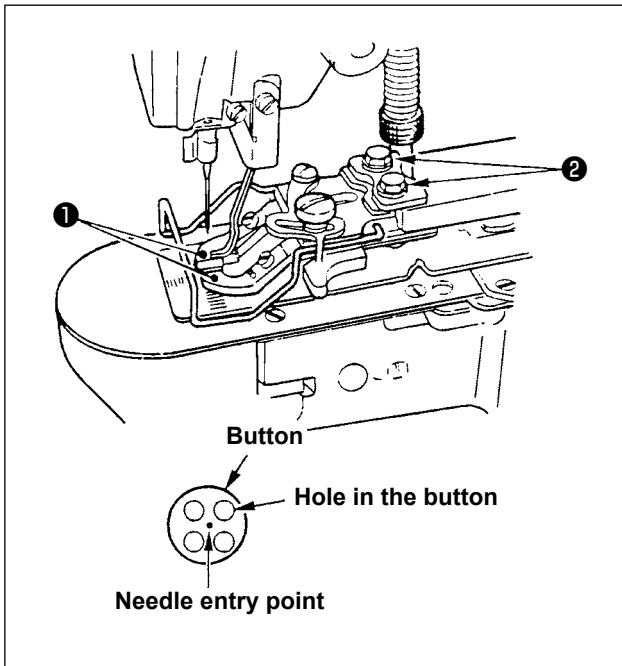

- 3) Press EDIT key  **8**. The button clamp unit travels to the origin and goes up.



- 4) Place a button in button clamp jaw levers ❶ .
- 5) Depress the pedal to the first step and detach your foot from the pedal when the button clamp unit comes down.
- 6) Turn the hand pulley and check that the center of the needle enters the center of the button.
- 7) If the center of the needle is not located in the center of the button, loosen screws ❷ in the button clamp jaw lever base to adjust so that the center of the needle enters the center of the button.
- 8) When depressing the pedal to the second step at step 5), the button clamp unit moves again to the origin position. In addition, when the button clamp unit comes down, depress the pedal to the first step and detach the foot from the pedal. Then the button clamp unit goes up.
- 9) After the adjustment, perform the confirmation of the pattern shape and make sure that the needle surely has entered the button hole.

3-2. Adjusting the feed plate



WARNING :

When change of the shape of the button, change of the sewing pattern or enlargement/reduction of the sewing width is performed, make sure of the shape of the sewing pattern. If the feed plate interferes with the needle hole guide, it will result in the danger of the needle breakage or the like. Also, if the pedal is depressed during the adjustment, the button clamp unit will go up or come down. So, be careful.

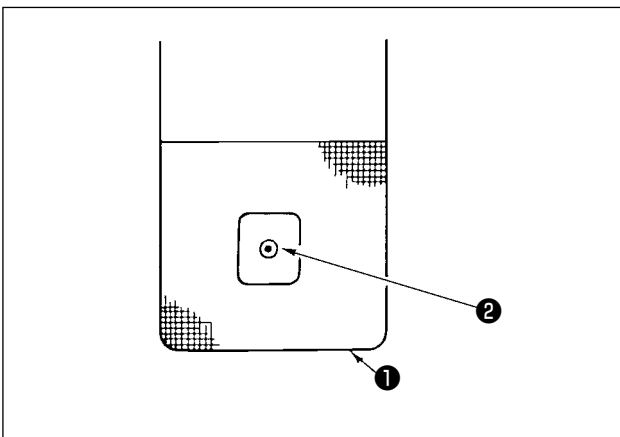

- 1) Put "08 Work clamp adjustment" in the selected state, referring to 1) and 2) in ["II.3-1. Position of the button clamp jaw lever" p.81](#).
- 2) Press EDIT key  . The button clamp unit goes to the origin position and goes up.
- 3) Adjust feed plate ❶ so that needle hole guide ❷ comes to the center of the recessed part of feed plate ❶ .

3-3. Adjusting the button clamp jaw lever



WARNING :

Turn OFF the power before starting the work so as to prevent accidents caused by abrupt start of the sewing machine.

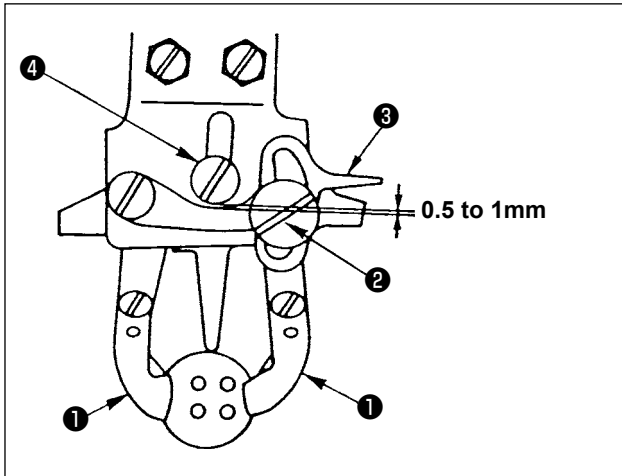

Bring the machine to its stop-motion state. Then lift button clamp ① . Loosen screw ② in the button clamp jaw lever and adjust so that a clearance of 0.5 to 1 mm is provided between button clamp jaw lever ③ and hinge screw ④ when placing a button in between button clamps ① . Then tighten screw ② in the button clamp jaw lever.

3-4. Adjusting the lifting amount of the button clamp



WARNING :

Turn OFF the power before starting the work so as to prevent accidents caused by abrupt start of the sewing machine.

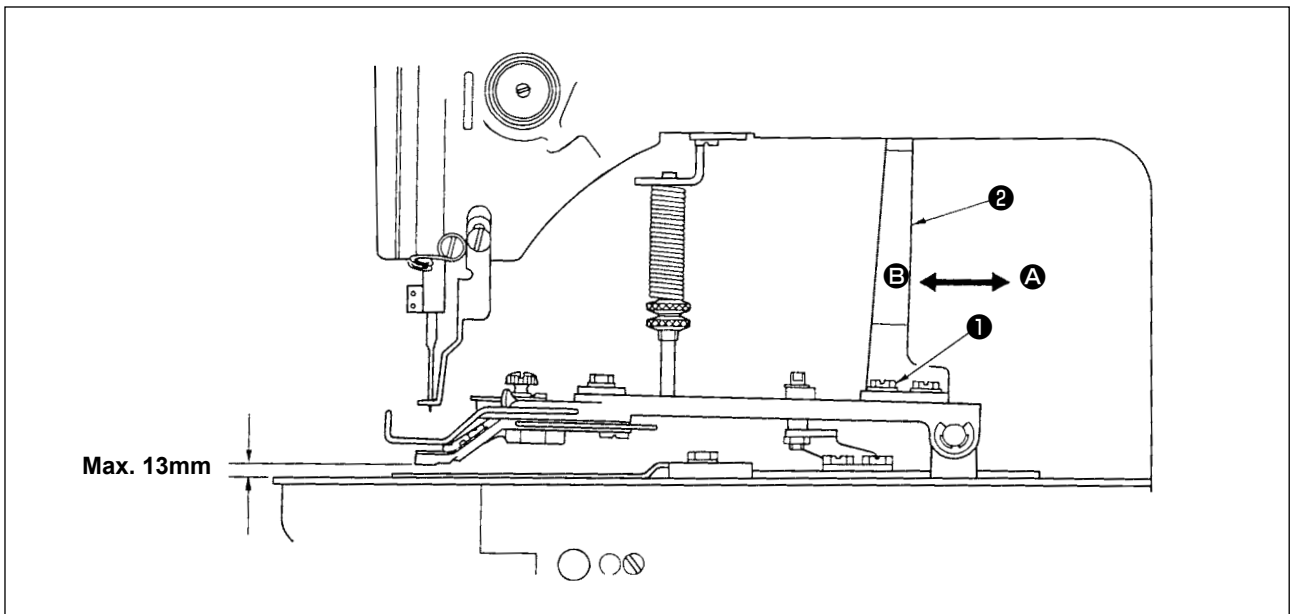

Loosen two setscrews ① , and move moving plate ② back and forth in the direction of arrow to adjust. The lifting amount of the button clamp will be decreased when moving plate ② is moved in the direction of A , and be increased when it is moved in the direction of B . After the adjustment, securely tighten setscrews ① .

3-5. Adjustment of the pressure of the work clamp unit



WARNING :

Turn OFF the power before starting the work so as to prevent accidents caused by abrupt start of the sewing machine.

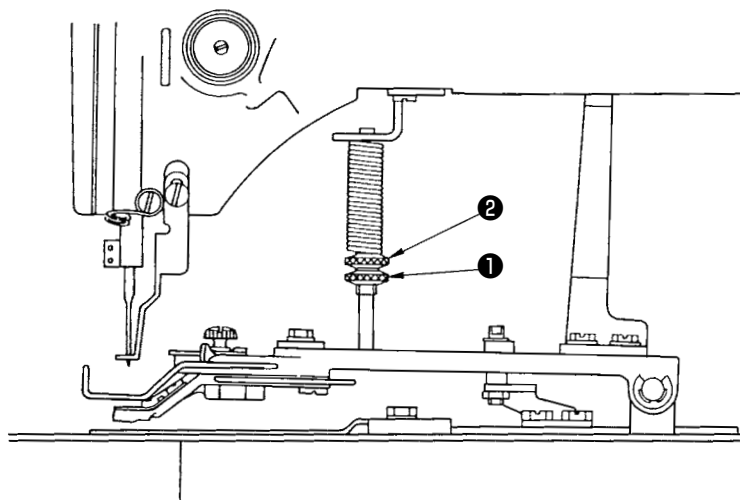

The pressure of the work clamp unit should be minimized as long as the material does not warp during sewing. Loosen adjusting screw ① and turn adjusting screw ② to obtain the aforementioned pressure.

3-6. Adjustment of the wiper spring



WARNING :

Turn OFF the power before starting the work so as to prevent accidents caused by abrupt start of the sewing machine.

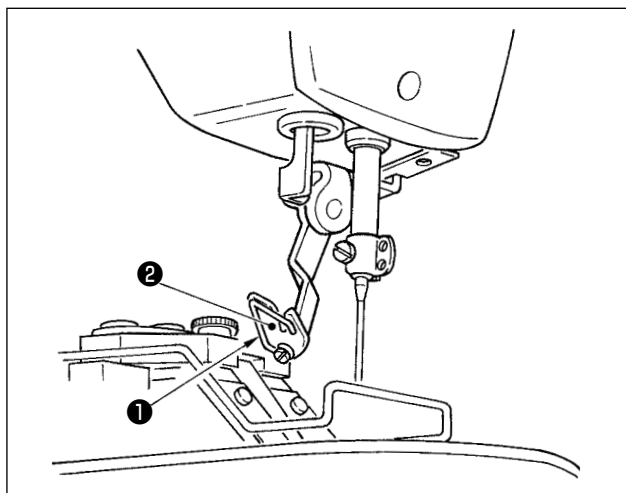

Wiper spring ① retains the needle thread after thread trimming in between wiper ② and the wiper spring. Correct properly the tension of wiper spring ① so that the tension at that time becomes 0.2 to 0.3N (a little higher tension than that of the bobbin thread coming out of the bobbin case).



If the retaining of the needle thread is excessive, the thread may protrude from the upper side of the button.

4. OTHERS

4-1. Installing the save button bar (accessory part)



WARNING :

Turn OFF the power before starting the work so as to prevent accidents caused by abrupt start of the sewing machine.

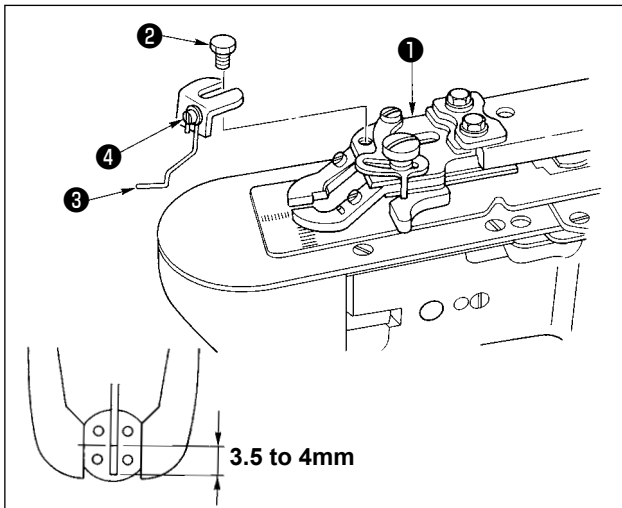

- 1) Install save button bar ③ on button clamp base ① with hexagon screw ② .
- 2) Adjust so that a clearance of 3.5 to 4 mm is provided between the center of the button and the top end of the save button bar.
- 3) To adjust the raising amount of the save button bar, loosen screw ④ , and move the save button bar up or down.

4-2. Model classification according to the button size

Model		LK-1903S-301	LK-1903S-302			
Button size classification		For small-sized buttons	For medium-sized button			
Outside diameter of applicable buttons (mm)		ø10 to ø20	ø10 to ø20			
Sewing size (mm)	Length	0 to 3.5	0 to 4.5			
	Width	0 to 3.5	0 to 4.5			
Button clamp jaw lever	Thickness (mm)	2.2 (2.7)	※	2.7 (2.2)	※	
	Part No.	Right	MAZ155070B0	B	MAZ156070B0	C
			(MAZ156070B0)	C	(MAZ155070B0)	B
	Left	MAZ155080B0	B	MAZ156080B0	C	
		(MAZ156080B0)	C	(MAZ155080B0)	B	
Needle hole guide		MAZ15501000	MAZ15601000			
Feed plate		MAZ15502000	MAZ15602000			

The part in parentheses are those to be specially ordered.

※ Engraved marker

4-3. Attaching the shank button (optional)

(1) Specifications

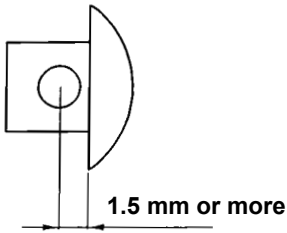
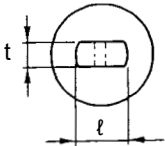
Model	Optional														
Needle	TQx3 #14														
Shape of button	Outside diameter	Max. $\phi 20$													
	Diameter of hole	Min. $\phi 1.5$													
	Position of hole	 <p>1.5 mm or more</p>													
Shape of shank section	 <table border="1" data-bbox="1059 775 1398 965"> <thead> <tr> <th rowspan="2">t</th> <th colspan="2">l(mm)</th> </tr> <tr> <th>Minimum</th> <th>Maximum</th> </tr> </thead> <tbody> <tr> <td>1</td> <td>4</td> <td>9</td> </tr> <tr> <td>3</td> <td>3</td> <td>8</td> </tr> <tr> <td>5</td> <td>-</td> <td>7</td> </tr> </tbody> </table> <p>As for the dimensions of the shape of shank section, refer to the above table for reference.</p>	t	l(mm)		Minimum	Maximum	1	4	9	3	3	8	5	-	7
t	l(mm)														
	Minimum	Maximum													
1	4	9													
3	3	8													
5	-	7													
Sewing speed	Max. speed of the pattern data is limited to 2,700 sti/min. However, set it to 1,500 sti/min for the shank button.														
Stitch shape	Sewing pattern program No.18 to No.22 (Refer to < Sewing program list > of "II.2-3. Various sewing modes" p.80.)														

(2) Adjusting the height of the needle bar



WARNING :

Turn OFF the power before starting the work so as to prevent accidents caused by abrupt start of the sewing machine.

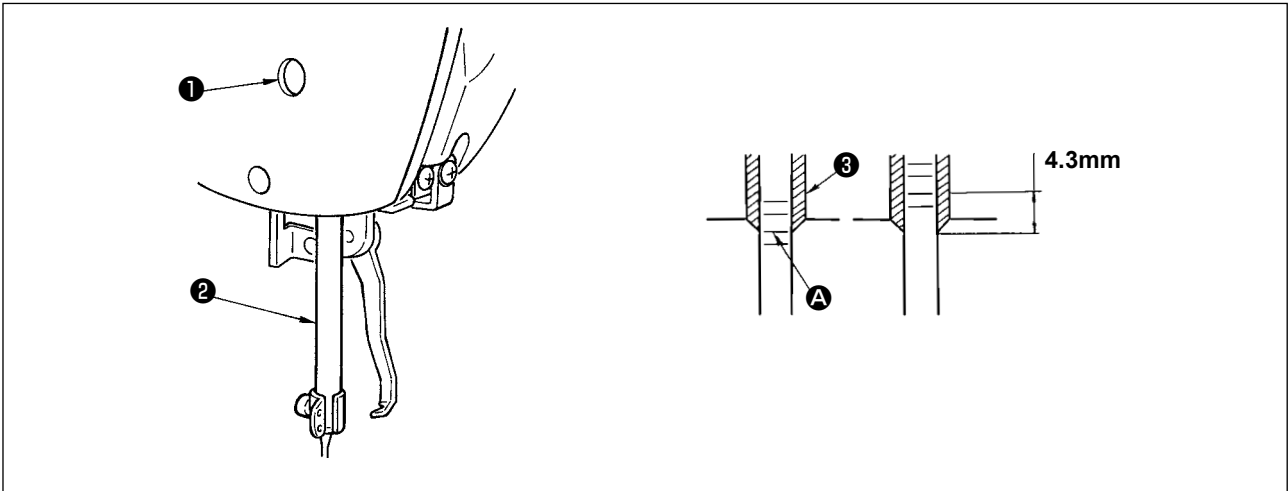

- 1) Loosen needle bar connection screw ① and move the needle bar ② up or down so that second engraved marker line A as counted from the bottom is aligned with the bottom end of needlebar bushing ③ when turning the hand pulley to bring the needle bar to its lowest position. Then further raise only the needle bar by 4.3mm, and tighten needle bar connection screw ① .
- 2) Attach the needle (TQx3 #14).

(3) Adjusting the feed plate base



WARNING :

Turn OFF the power before starting the work so as to prevent accidents caused by abrupt start of the sewing machine.

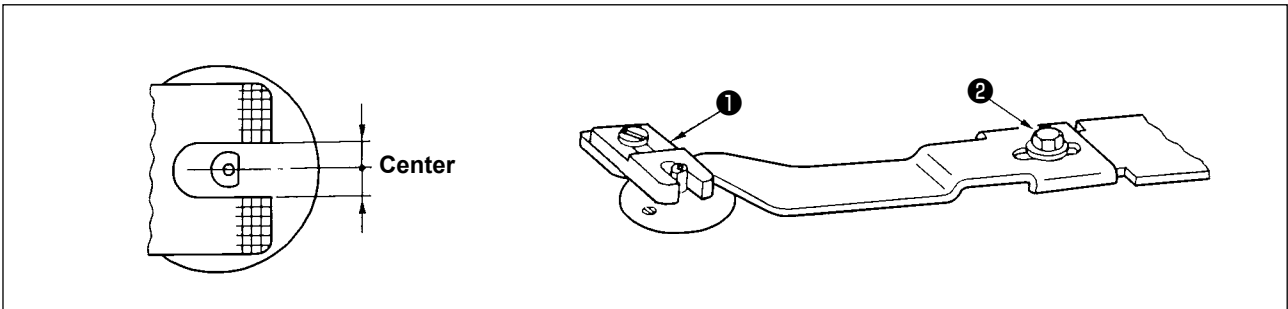

Adjust so that the slot of feed plate ① becomes the center of the boss section of the needle hole guide, and tighten setscrew ② .



When the sewing state between the button and the material is loose, replace feed plate ① with the feed plate B to obtain a stronger sewing state. At this time, however, the outside diameter of the button is limited to max. $\phi 19$. So, be careful.

(4) Adjusting the button clamp support



WARNING :
Turn OFF the power before starting the work so as to prevent accidents caused by abrupt start of the sewing machine.

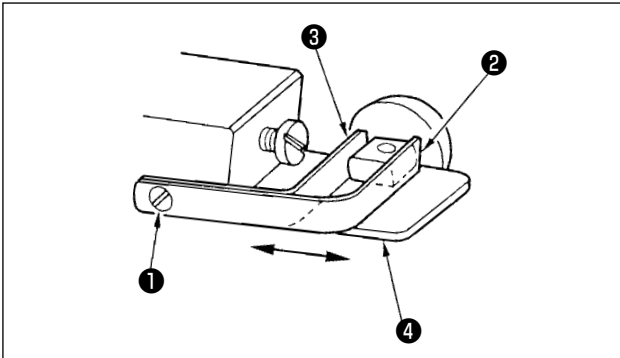

Loosen setscrew ①, and place the button to be used in between the button clamps. Then determine the longitudinal position of the button hole and the slot of button clamp base ④ by moving button clamp support, front ② and rear ③ back and forth. Then securely tighten the setscrew. At this time, if the clearance between button clamp support, front ② and rear ③ is a little smaller (approx. 0.5mm) than the outside diameter of the button to be placed, the button is securely clamped.

(5) Checking the needle entry point



WARNING :
Turn OFF the power before starting the work so as to prevent accidents caused by abrupt start of the sewing machine.

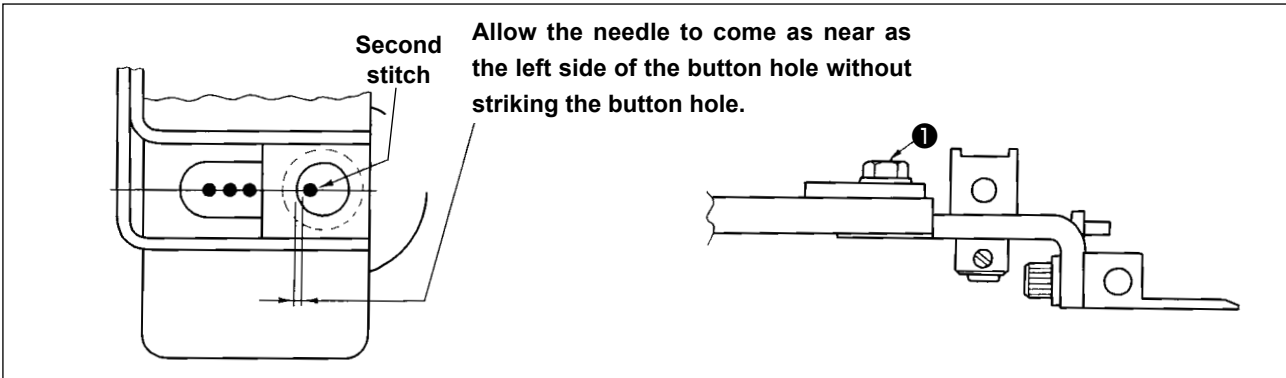

When checking the shape of the sewing pattern, fit the second stitch of the needle entry to the button hole, and tighten screw ①. (Refer to the item of checking the shape of the sewing pattern in the instruction manual for the LK-1900S "I.5-4. Checking the contour of a sewing pattern" p.21.)

(6) Adjusting the button clamp base and the feed plate



WARNING :
Turn OFF the power before starting the work so as to prevent accidents caused by abrupt start of the sewing machine.

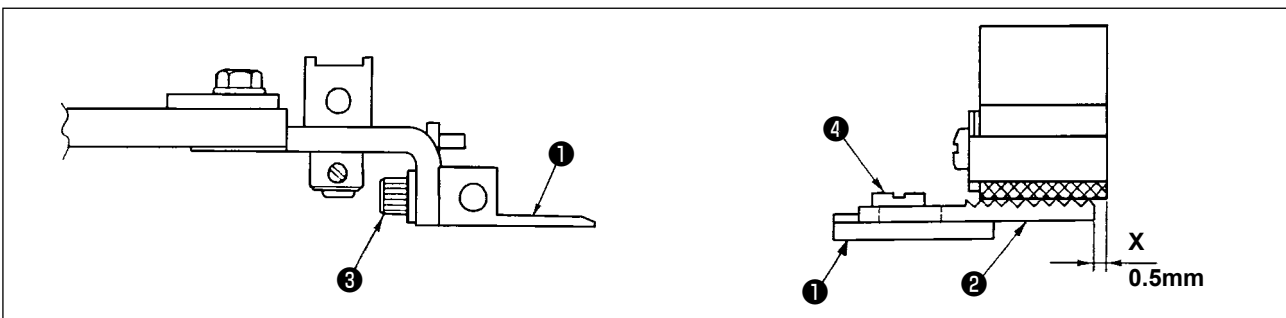

- 1) As for the attaching height of button clamp base ①, adjust the vertical position so that the bottom face of the button clamp base and the top face (knurl face) of feed plate A ② can equally press the material. Then tighten setscrew ③.
- 2) Adjust the position X (protrusion of the material), position of feed plate A ② against button clamp base ①, according to the thickness of the material using setscrew ④. The standard adjustment value is 0.5 mm.

(7) Adjusting the button support rubber



WARNING :

Turn OFF the power before starting the work so as to prevent accidents caused by abrupt start of the sewing machine.

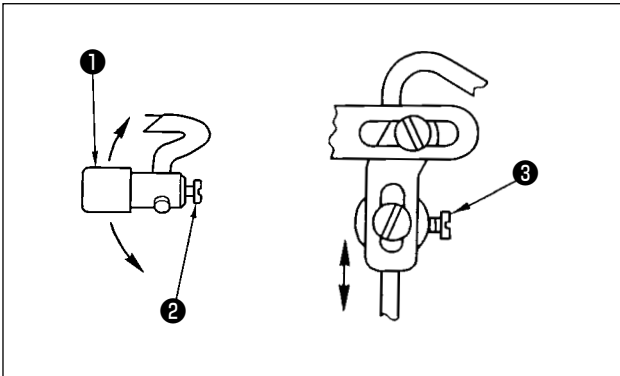

To adjust the position of button support rubber asm. ①, loosen setscrews ② and ③, and adjust so that the pressing section of the button support rubber can press the center of the button at right angles to the button. Then tighten the setscrews.

(8) Adjusting the button support link



WARNING :

Turn OFF the power before starting the work so as to prevent accidents caused by abrupt start of the sewing machine.

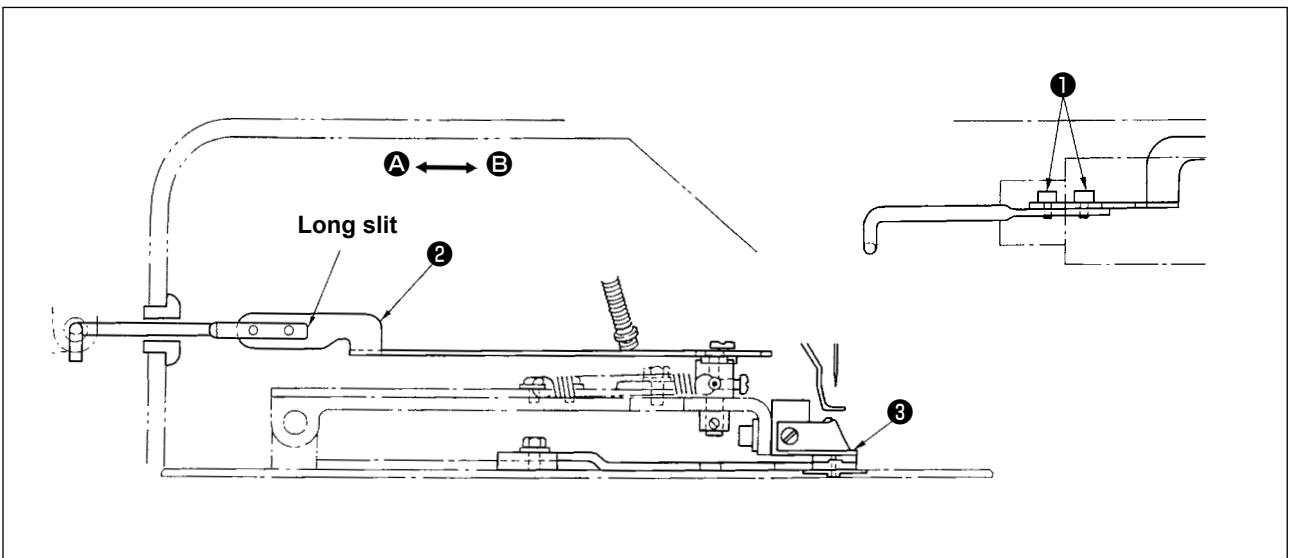

Loosen screw ①, and move button support link ② in the direction ④ to make early the opening of the button support rubber when button clamp attaching base ③ goes up. Move it in the direction ⑤ to retard the opening of the button support rubber. The standard adjustment is to adjust so that the button support rubber starts opening when button clamp attaching base ③ has gone up by 1 mm.

III. DRAWING OF THE TABLE

Longitudinal installation type table (Part No. 40143093)

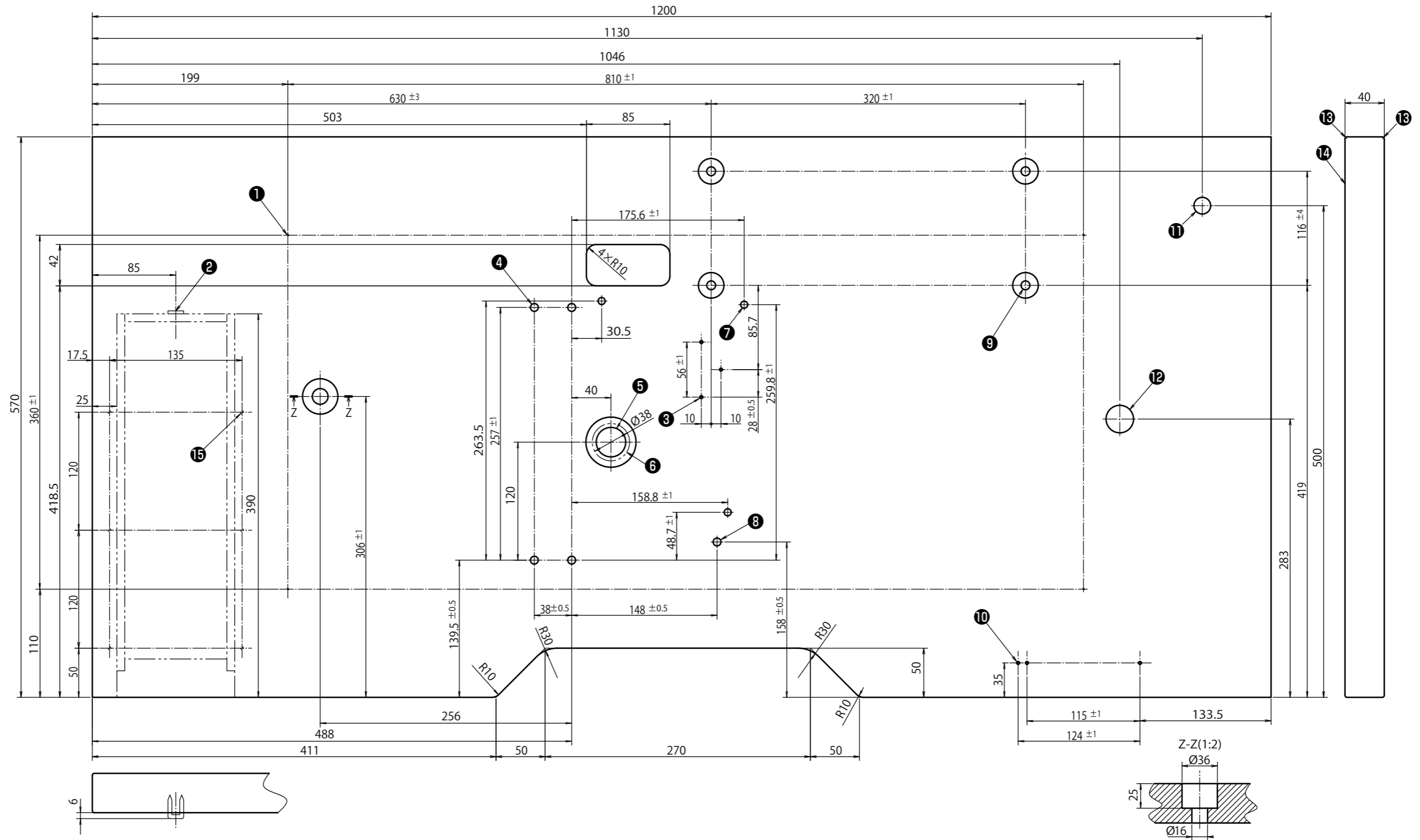

- ① 4- drilled hole 2, 10 deep on the rear side (stand installing hole)
- ② Drawer stopper installing position (one place on the rear side)
- ③ 3- drilled hole 3, 10 deep on the rear side (pedal installing hole)
- ④ 4- drilled hole 8
- ⑤ Drilled hole 30, 51 spot face 16 deep
- ⑥ Oil drain funnel installing hole
- ⑦ 3- drilled hole 7, 6 deep
- ⑧ Drilled hole 8
- ⑨ 4-drilled hole 9, 26 spot face 1 deep
- ⑩ 3-drilled hole 3, 10 deep on the rear side (power switch installing hole)
- ⑪ Drilled hole 17
- ⑫ Drilled hole 28
- ⑬ R2 (all corners)
- ⑭ Right side
- ⑮ 6- drilled hole 3, 10 deep on the rear side (drawer installing hole)

Lateral installation type table

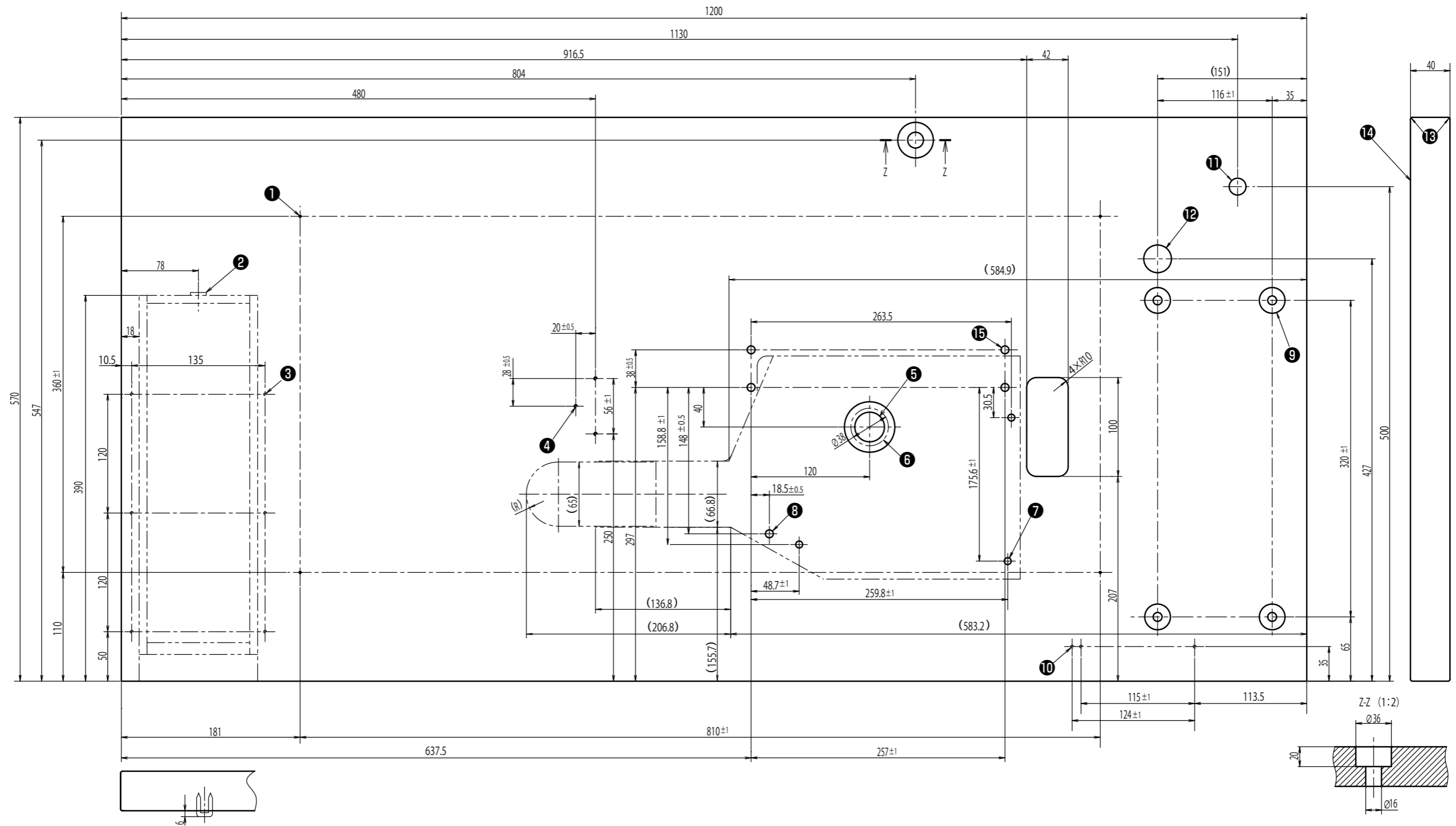

- | | |
|----------------------------------------------------------------------------------------------------------------------------------------------------------------------------------------------------------------------------------------------------------------------------------------------------------------------------------------------------------------------------------------------------------------------------------------------------------------------|--------------------------------------------------------------------------------------------------------------------------------------------------------------------------------------------------------------------------------------------------------------|
| <p>① 4- drilled hole 2, 10 deep on the rear side (stand installing hole)</p> <p>② Drawer stopper installing position (one place on the rear side)</p> <p>③ 6- drilled hole 3, 10 deep on the rear side (drawer installing hole)</p> <p>④ 3- drilled hole 3, 10 deep on the rear side (pedal installing hole)</p> <p>⑤ Drilled hole 30, 51 spot face 16 deep</p> <p>⑥ Oil drain funnel installing hole</p> <p>⑦ 3- drilled hole 7, 6 deep</p> <p>⑧ Drilled hole 8</p> | <p>⑨ 4-drilled hole 9, 26 spot face 7 deep</p> <p>⑩ 3-drilled hole 3, 10 deep on the rear side (power switch installing hole)</p> <p>⑪ Drilled hole 17</p> <p>⑫ Drilled hole 28</p> <p>⑬ R2 (all corners)</p> <p>⑭ Right side</p> <p>⑮ 4- drilled hole 8</p> |
|----------------------------------------------------------------------------------------------------------------------------------------------------------------------------------------------------------------------------------------------------------------------------------------------------------------------------------------------------------------------------------------------------------------------------------------------------------------------|--------------------------------------------------------------------------------------------------------------------------------------------------------------------------------------------------------------------------------------------------------------|